

R. MARSH.
Lamp Bracket.

No. 107,699.

Patented Sept. 27, 1870.

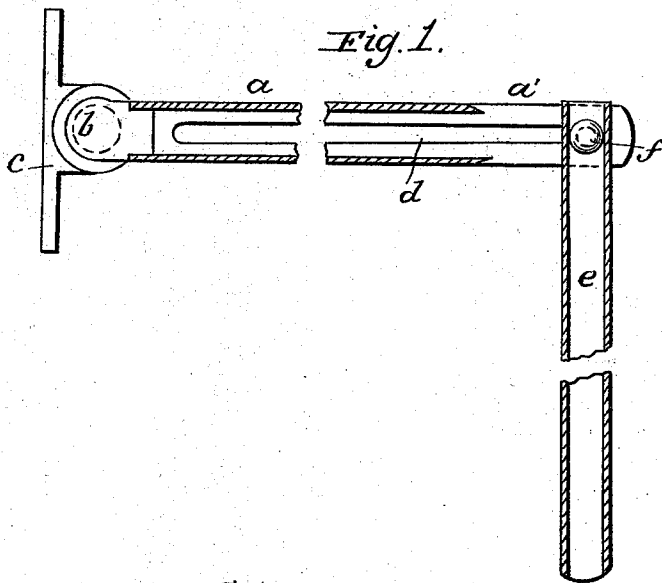
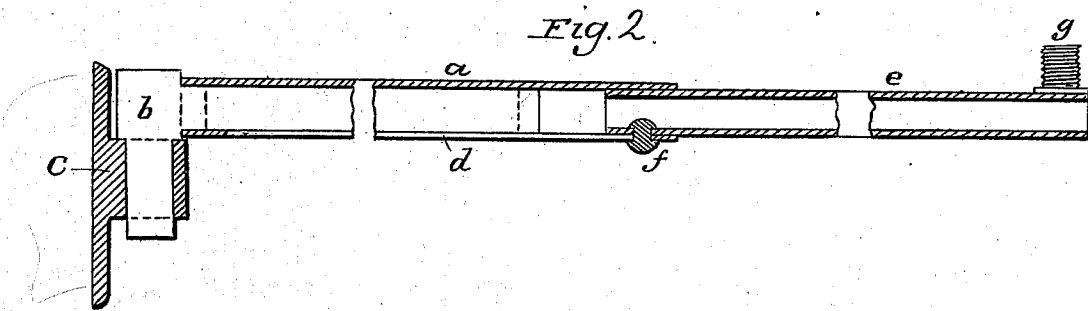

Witnesses:
R. Craighead
W. J. Still

Inventor:
Riverius Marsh

United States Patent Office.

RIVERIUS MARSH, OF NEW YORK, N. Y.

Letters Patent No. 107,699, dated September 27, 1870.

IMPROVEMENT IN LAMP-BRACKETS.

The Schedule referred to in these Letters Patent and making part of the same.

Be it known that I, RIVERIUS MARSH, of the city, county, and State of New York, have invented a new and useful Improvement in Brackets for Lamps, of which the following is a specification.

The nature of my invention consists of a bracket of telescopic form, so arranged that the inner portion may be extended or drawn out to any required distance from the wall, and so arranged that, when the inner portion is drawn out, it forms a hinge with the outer portion, whereby the lamp attached to said bracket may be swung around horizontally in either direction.

In the drawing—

Figure 1 represents a horizontal section, and

Figure 2 a vertical section of my improvement.

a is a square hollow arm or tube, secured at one end to a hinge, *b c*, of any ordinary construction, said hinge being secured to the wall, post, or other structure.

d is a slot in the bottom of the tube *a*, extending nearly its entire length.

e is a square rod or tube, sliding into the tube *a*.

f is a rivet, screw, or pin passing through the slot *d*, and through a hole in the end of the tube *e*, as shown.

g is a screw, to which may be attached the fixtures for supporting the lamp, in any convenient manner.

In operating this bracket it will be seen that the tube *e* can be run into the tube *a* nearly or quite its entire length, and can be set at any required distance from the wall, and, as the sides of the tube *a* are cut away at the point *a'*, as shown, the tube *e*, when drawn out, will swing around either way horizontally upon the rivet *f*.

I claim as my invention—

A telescopic lamp-bracket, constructed, arranged, and operated in a manner substantially as and for the purposes set forth.

RIVERIUS MARSH.

Witnesses:

R. CRAIGHEAD.

N. G. STILL.