

[54] INDUSTRIAL ROBOT

[75] Inventors: Masato Shibayama, Sayama; Takeshi Abe, Tokyo; Ko Tsuji, Hunabashi; Akira Uchida; Masayuki Ohshiro, both of Narashino, all of Japan.

[73] Assignee: Hitachi, Ltd., Tokyo, Japan

[**] Term: 14 Years

[21] Appl. No.: 701,522

[22] Filed: Feb. 14, 1985

[30] Foreign Application Priority Data

Aug. 17, 1984 [JP] Japan 59-34381
Aug. 17, 1984 [JP] Japan 59-34382
[52] U.S. Cl. D15/199; D15/122
[58] Field of Search D15/122, 199; 414/729, 414/730, 731, 732, 733, 734, 735, 736, 737, 738, 739, 740, 741, 742

[56] References Cited

U.S. PATENT DOCUMENTS

D. 268,033	2/1983	Stackhouse	D15/199
D. 269,681	7/1983	Morser et al.	D15/122
D. 279,571	7/1985	Arai et al.	D15/122
D. 280,203	8/1985	Shibayama et al.	D15/199
4,512,709	4/1985	Hennekes et al.	414/729
4,626,165	12/1986	Nakashima et al.	414/735

Primary Examiner—B. J. Bullock
Attorney, Agent, or Firm—Antonelli, Terry & Wands

[57] CLAIM

The ornamental design for an industrial robot, as shown and described.

DESCRIPTION

FIG. 1 is a front, top and right side perspective view of an industrial robot showing our new design; FIG. 2 is a front elevational view thereof; FIG. 3 is a left side elevational view thereof; FIG. 4 is a right side elevational view thereof; FIG. 5 is a top plan view thereof; FIG. 6 is a bottom plan view thereof; FIG. 7 is a rear elevational view thereof; and FIG. 8 is a front, top and right side perspective view thereof, the arm being in an alternate position; FIG. 9 is a front, top and right side perspective view of a second embodiment of the design of FIG. 1; FIG. 10 is a front elevational view of FIG. 9; FIG. 11 is a left side elevational view of FIG. 9; FIG. 12 is a right side elevational view of FIG. 9; FIG. 13 is a top plan view of FIG. 9; FIG. 14 is a bottom plan view of FIG. 9; FIG. 15 is a rear elevational view of FIG. 9; FIG. 16 is a front, top and right side perspective view of FIG. 9, the arm being in an alternate position.

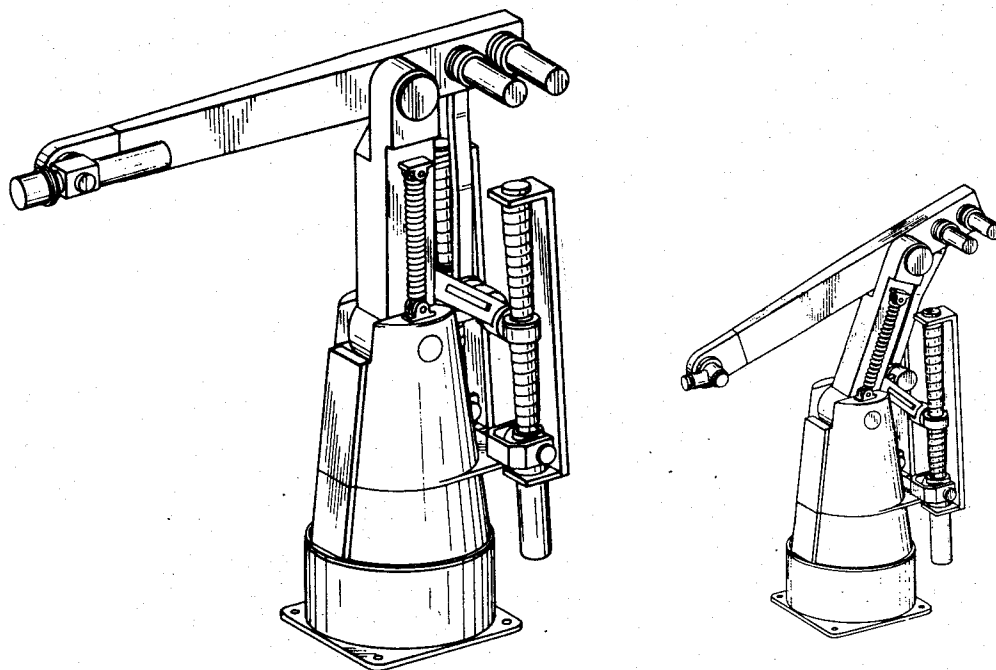

FIG. 2

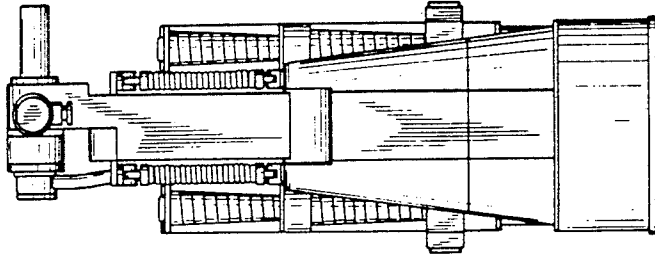

FIG. 1

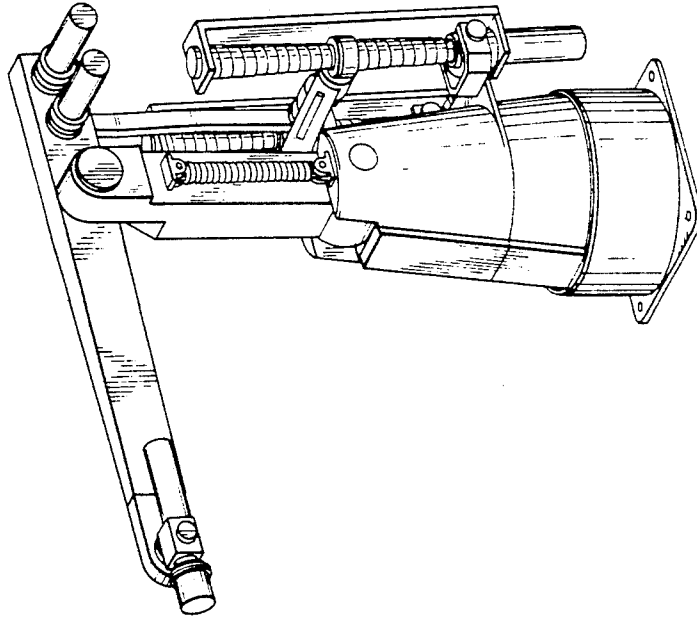

FIG. 4

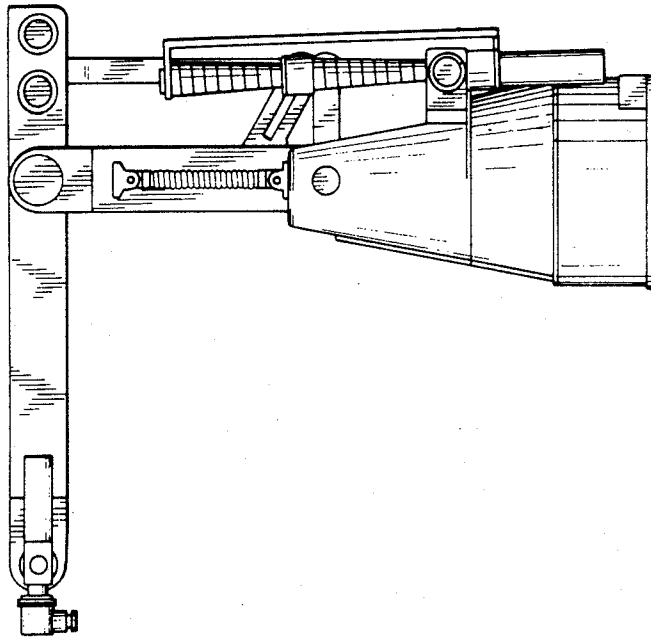

FIG. 3

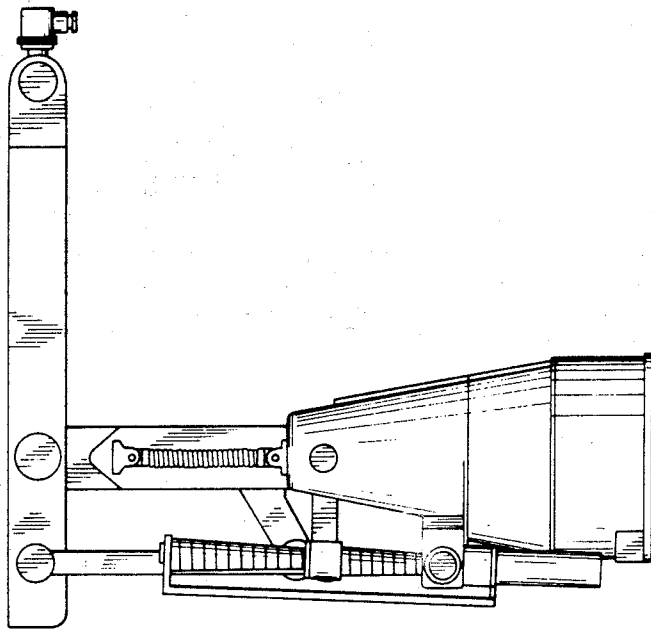

FIG. 6

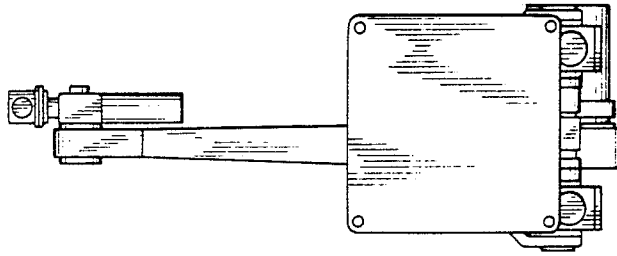

FIG. 5

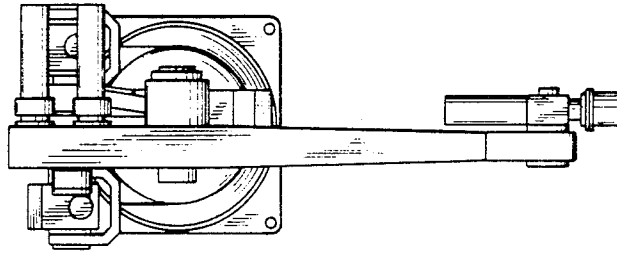

FIG. 8

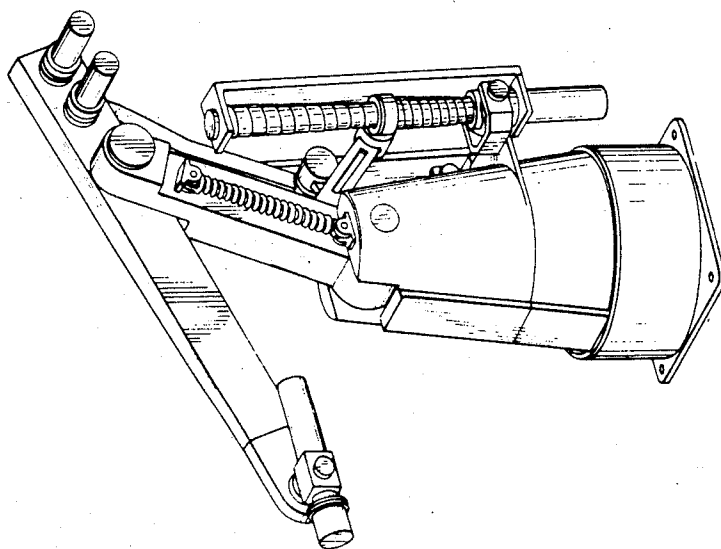

FIG. 7

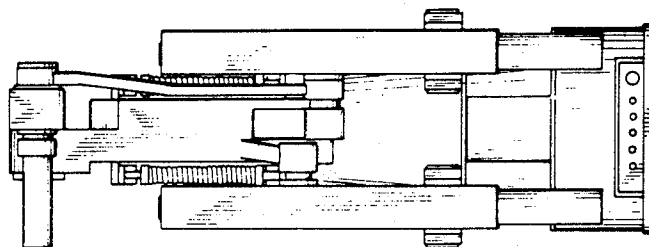

FIG. 10

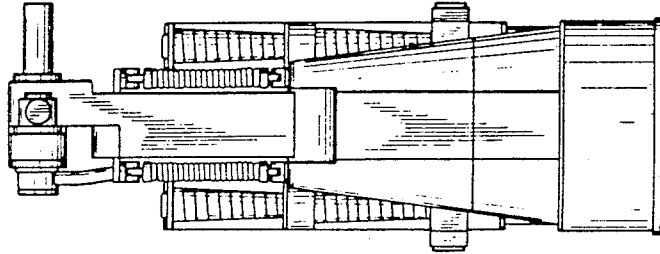

FIG. 9

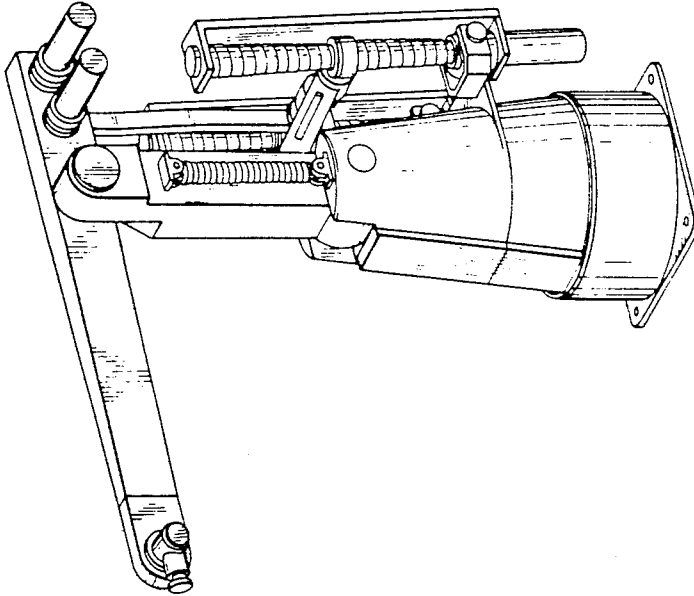

FIG. 12

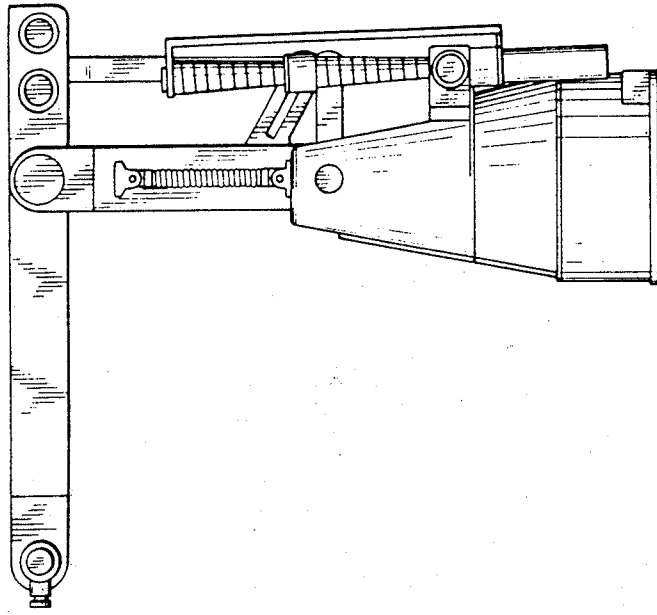

FIG. 11

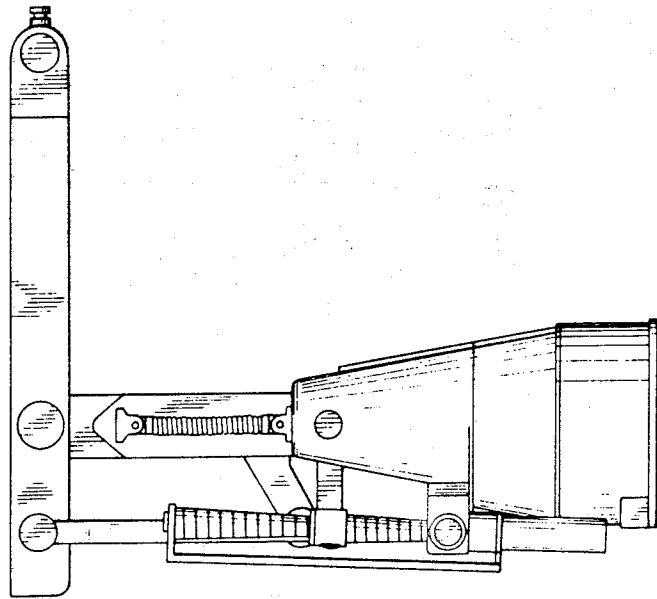

FIG. 14

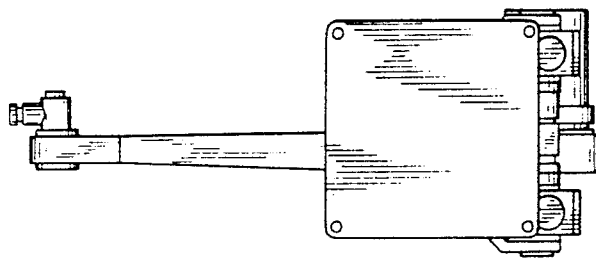

FIG. 13

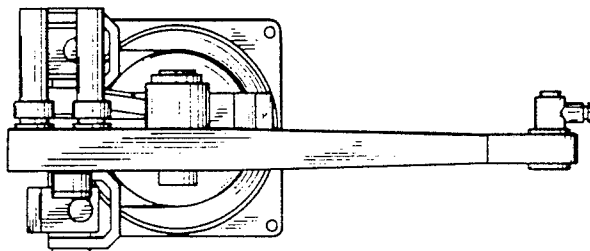

FIG. 16

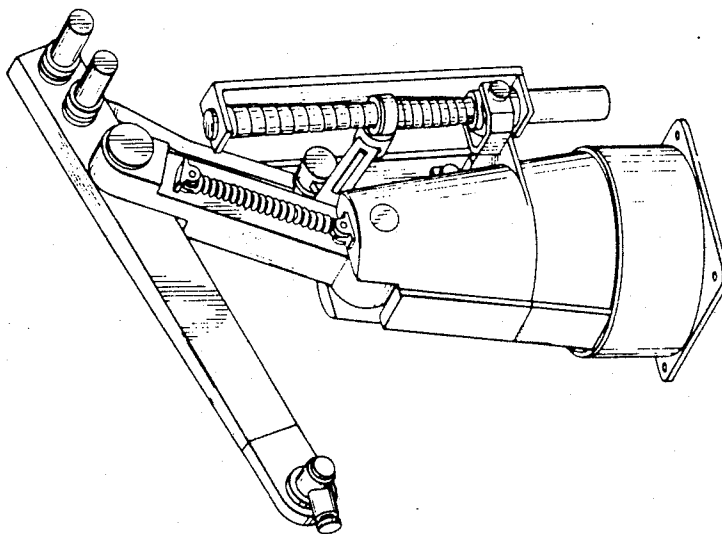

FIG. 15

