

Aug. 27, 1968

G. R. ECKHARDT

3,398,710

LOCK STITCH SEWING MACHINE THREAD CASE

Filed Sept. 1, 1966

Fig. 1.

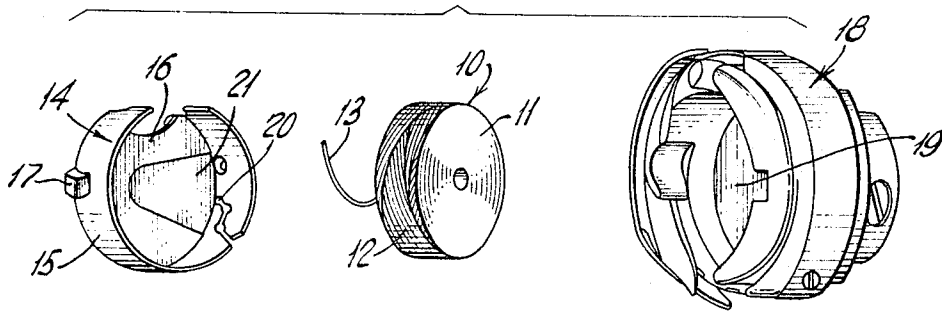

Fig. 2.

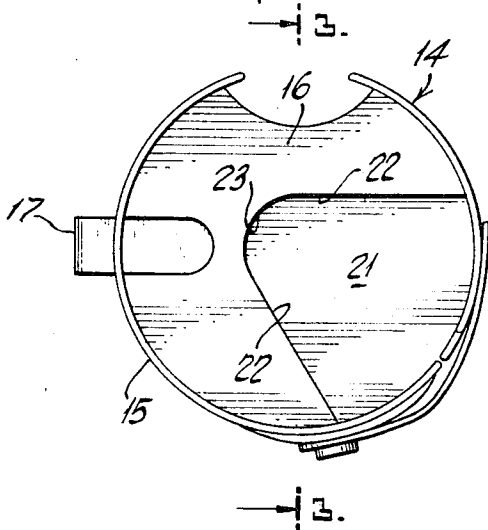
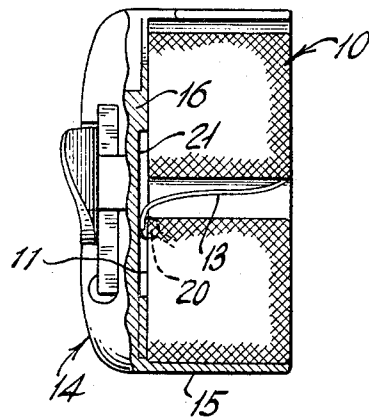

Fig. 3.



INVENTOR  
GEORGE R. ECKHARDT  
BY  
*Burgess, Ryan & Hicks*  
ATTORNEYS

1

3,398,710

**LOCK STITCH SEWING MACHINE  
THREAD CASE**

George R. Eckhardt, Fords-Edison Township, N.J., assignor to Coats & Clark Inc., New York, N.Y., a corporation of Delaware

Filed Sept. 1, 1966, Ser. No. 576,668  
5 Claims. (Cl. 112-231)

**ABSTRACT OF THE DISCLOSURE**

A thread case for center-unwind cops, said thread case having a groove in the end wall placed to allow clearance for the free passage of thread between said end wall and the end of the cop.

This invention relates to lock stitch sewing machines, and more particularly, to a thread case to be used in the loop taker of such machines for holding a center-unwind cop of thread.

Sewing thread is available for use in the loop taker mechanism of lock stitch sewing machines in the form of center-unwind cops or thread masses. Such a center-unwind cop is cylindrical in form and essentially solid before thread is removed therefrom. During use the cop is held in a thread case and the thread unwinds from the center of the cop. As it unwinds the thread passes between the inner wall of the thread case and the flat end wall of the cop, finally passing through the thread case side wall, which is suitably apertured for this purpose.

It is desirable that the thread, as it unwinds, pass freely between the inner end wall of the thread case and the end of the cop. It is an object of this invention to facilitate this motion.

In the drawings:

FIG. 1 is an exploded view of a thread case, a center-unwind cop, and a thread case carrier;

FIG. 2 is an end view of a thread case, showing the inside thereof; and

FIG. 3 is a cross sectional view on cutting plane 3-3 of FIG. 2.

FIG. 1 shows a center-unwind cop 10 with a flat end surface 11 and a cylindrical side surface 12. A thread is shown at 13 emerging from the center of the cop.

A thread case 14 has a cylindrical side wall 15 and an end wall 16. A sliding latch 17 is adapted to lock the thread case within a thread case carrier 18 after the thread case has been properly loaded with a center-unwind cop. As may best be seen in FIG. 3, the cop may be a close fit within the thread case, and will often be squeezed between end wall 16 and the back wall 19 of the thread case carrier.

The thread as it is pulled from the cop is led from the center of the cop across the end surface 11 of the cop and through an aperture 20 cut through side wall 15 of the thread case. In order to prevent pinching of the thread as it unwinds in this fashion an improved end wall structure is provided. The improvement comprises a fan-shaped recess sunk into the end wall 16 and defined by a portion of the side wall 15, by recessed surface 21, and by a step comprised of straight step segments 22, 22 and an arcuate step segment 23. The arcuate step segment 23 is concentric with side wall 15, so that recessed surface

2

21 extends to the area adjacent the center of cop 10 when the latter is in place.

The fan-shaped recess provides clearance for the thread as it unwinds from the center of the cop and travels out through aperture 20. The remaining surface of end wall 16 bears against the cop and holds it in place. The depth of the recess may be in the order of 0.01 inch.

A simple channel reaching from the center of the thread case end wall 16 to the aperture 20 and having a width slightly greater than the diameter of the thread may serve to avoid compression of the thread by the end surface 11 of the cop 10, if the thread is properly centered therein. However, it is a difficult matter on inserting a cop to insure that the thread lies completely in such a channel, especially as the cop may not be perfectly centered within the thread case. Also, as thread is used up, it feeds out from the wall of the growing central hole in the cop, not from the geometrical center thereof, and this off-center feed may make jamming more likely if only a narrow channel is employed. The fan-shaped recess illustrated in the preferred embodiment of the invention avoids (or at least greatly reduces the probability of) thread being pinched between the end wall 16 and the cop during loading. That is, when the thread end has been led through aperture 20 and the cop pressed into the thread case, the unwound thread will usually be found lying with the recess and thus in a position to feed freely from the cop.

The following is claimed:

1. In a thread case adapted for use with a center-unwind cop, said thread case having an end wall adapted to abut an end surface of the cop, said thread case having a side wall adjoining the end wall and adapted to surround a cylindrical side surface of the cop, and said thread case having aperture surfaces defining an aperture through the thread case in the vicinity of the juncture between the end wall and the side wall, said aperture surfaces being adapted to surround a thread as said thread feeds from the cop, across the end surface of the cop, and out of the thread case through the aperture during the formation of stitches, the improvement comprising a groove in the end wall of the thread case for the free passage of thread between said end wall and the end of the cop, said groove extending from the center of the end wall to the aperture and being open along its length to the space adapted for occupancy by the cop.

2. The device of claim 1 wherein the groove is defined by a substantially fan-shaped recessed surface bordered by the side wall and by a step, the fan-shaped recessed surface having its apex substantially at the center of the end wall.

3. The device of claim 2 wherein the recessed surface is depressed approximately one one-hundredth of an inch below the inner surface of the end wall.

4. In a thread case adapted for use with a center-unwind cop, said thread case having an end wall, a side wall adjoining the end wall, and surfaces defining an aperture through the thread case in the vicinity of the juncture between the end wall and the side wall, the improvement comprising surfaces defining a recessed channel in the end wall of the thread case, said channel extending from the center of the end wall to the vicinity of the aperture, said recessed channel being defined by a substantially fan-shaped recessed surface bordered by the side wall and by a step, the fan-shaped recessed surface having its apex substantially at the center of the end wall, said step com-

3

4

prising an arcuate step segment centered substantially at the center of the end wall and two straight step segments each joining the arcuate step segment and extending to the side wall, said straight step segments diverging as they approach the side wall.

5. The device of claim 4 wherein the straight step segments about the side wall at approximately equal distances on either side of the apertures.

References Cited

UNITED STATES PATENTS

	573,894	12/1896	Miller	-----	112-231
5	1,981,834	11/1934	Fleckenstein	-----	112-231
	2,851,977	9/1958	Spaine	-----	112-231

HERBERT F. ROSS, Primary Examiner.