



(86) Date de dépôt PCT/PCT Filing Date: 2005/05/09
 (87) Date publication PCT/PCT Publication Date: 2006/04/27
 (45) Date de délivrance/Issue Date: 2012/12/11
 (85) Entrée phase nationale/National Entry: 2006/11/22
 (86) N° demande PCT/PCT Application No.: US 2005/016085
 (87) N° publication PCT/PCT Publication No.: 2006/043983
 (30) Priorité/Priority: 2004/05/27 (US10/854,209)

(51) Cl.Int./Int.Cl. *B25B 11/00* (2006.01)
 (72) Inventeurs/Inventors:
 BOYL-DAVIS, THEODORE M., US;
 BUTTRICK, JAMES N., JR., US;
 JONES, DARRELL D., US
 (73) Propriétaire/Owner:
 THE BOEING COMPANY, US
 (74) Agent: BULL, HOUSSER & TUPPER LLP

(54) Titre : DISPOSITIF ET PROCEDE DE VENTOUSE CONFORME

(54) Title: CONFORMAL VACUUM CUP APPARATUS AND METHOD FOR REMOVABLY ATTACHING A RAIL TO A SURFACE OF A WORKPIECE

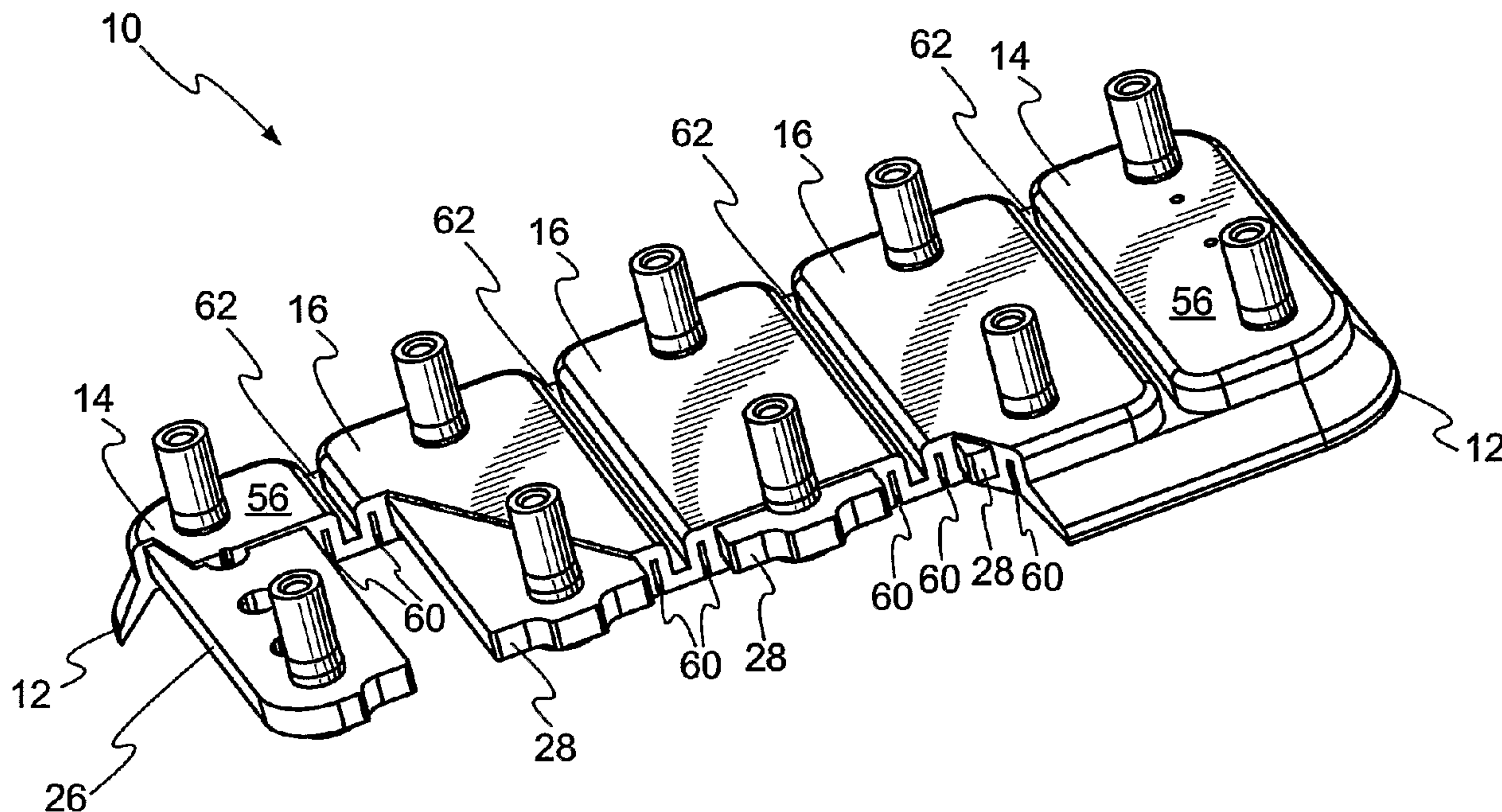

(57) Abrégé/Abstract:

A conformal vacuum cup (10) provides a machine tool attachment fitting usable in a flexible-track drill system. Using multiple, independently articulated stiffeners (26, 28), the conformal vacuum cup conforms to the contour of complex aerospace surface shapes (70). The individual stiffeners (26, 28) are decoupled from each other to some extent by grooves (62) and slots (60) molded into resilient overmolding material to support long-axis curving. Spacing pins (18) employ a domed shape consonant with the elastic deformation of the workpiece surface (70) under load. The pins (18) employ a hard material to prevent particle embedment in use and to control position tolerance for drill heads and other tools traveling on the flexible track. Partial holes (24, 54) in each vacuum cup (10) are blocked by diaphragms (58). Interconnection from a vacuum system manifold to the vacuum cups can be realized by penetrating the diaphragms (58) and inserting barbed fittings (64) connected by vacuum tubing (68).

(12) INTERNATIONAL APPLICATION PUBLISHED UNDER THE PATENT COOPERATION TREATY (PCT)

(19) World Intellectual Property Organization
International Bureau(43) International Publication Date
27 April 2006 (27.04.2006)

PCT

(10) International Publication Number
WO 2006/043983 A3(51) International Patent Classification:
B25B 11/00 (2006.01)(21) International Application Number:
PCT/US2005/016085

(22) International Filing Date: 9 May 2005 (09.05.2005)

(25) Filing Language: English

(26) Publication Language: English

(30) Priority Data:
10/854,209 27 May 2004 (27.05.2004) US(71) Applicant (for all designated States except US): **THE BOEING COMPANY** [US/US]; 100 N. Riverside Plaza, Chicago, IL 60606 (US).

(72) Inventors; and

(75) Inventors/Applicants (for US only): **BOYL-DAVIS, Theodore, M.** [US/US]; 11516 42nd Place SE, Snohomish, WA 98290 (US). **BUTTRICK, James, N., Jr.** [US/US]; 8015 Ridge Drive NE, Seattle, WA 98115 (US). **JONES, Darrell, D.** [US/US]; 16723 1st Avenue SE, Mill Creek, WA 98012 (US).(74) Agents: **SAVAGE, Laurence, A.** et al.; The Boeing Company, 15460 Laguna Canyon Road, Mc 1650-7006, Irvine, CA 92618 (US).

(81) Designated States (unless otherwise indicated, for every kind of national protection available): AE, AG, AL, AM, AT, AU, AZ, BA, BB, BG, BR, BW, BY, BZ, CA, CH, CN, CO, CR, CU, CZ, DE, DK, DM, DZ, EC, EE, EG, ES, FI, GB, GD, GE, GH, GM, HR, HU, ID, IL, IN, IS, JP, KE, KG, KM, KP, KR, KZ, LC, LK, LR, LS, LT, LU, LV, MA, MD, MG, MK, MN, MW, MX, MZ, NA, NG, NI, NO, NZ, OM, PG, PH, PL, PT, RO, RU, SC, SD, SE, SG, SK, SL, SM, SY, TJ, TM, TN, TR, TT, TZ, UA, UG, US, UZ, VC, VN, YU, ZA, ZM, ZW.

(84) Designated States (unless otherwise indicated, for every kind of regional protection available): ARIPO (BW, GH, GM, KE, LS, MW, MZ, NA, SD, SL, SZ, TZ, UG, ZM, ZW), Eurasian (AM, AZ, BY, KG, KZ, MD, RU, TJ, TM), European (AT, BE, BG, CH, CY, CZ, DE, DK, EE, ES, FI, FR, GB, GR, HU, IE, IS, IT, LT, LU, MC, NL, PL, PT, RO, SE, SI, SK, TR), OAPI (BF, BJ, CF, CG, CI, CM, GA, GN, GQ, GW, ML, MR, NE, SN, TD, TG).

Published:

— with international search report

(88) Date of publication of the international search report:
20 July 2006

For two-letter codes and other abbreviations, refer to the "Guidance Notes on Codes and Abbreviations" appearing at the beginning of each regular issue of the PCT Gazette.

(54) Title: CONFORMAL VACUUM CUP APPARATUS AND METHOD FOR REMOVABLY ATTACHING A RAIL TO A SURFACE OF A WORKPIECE

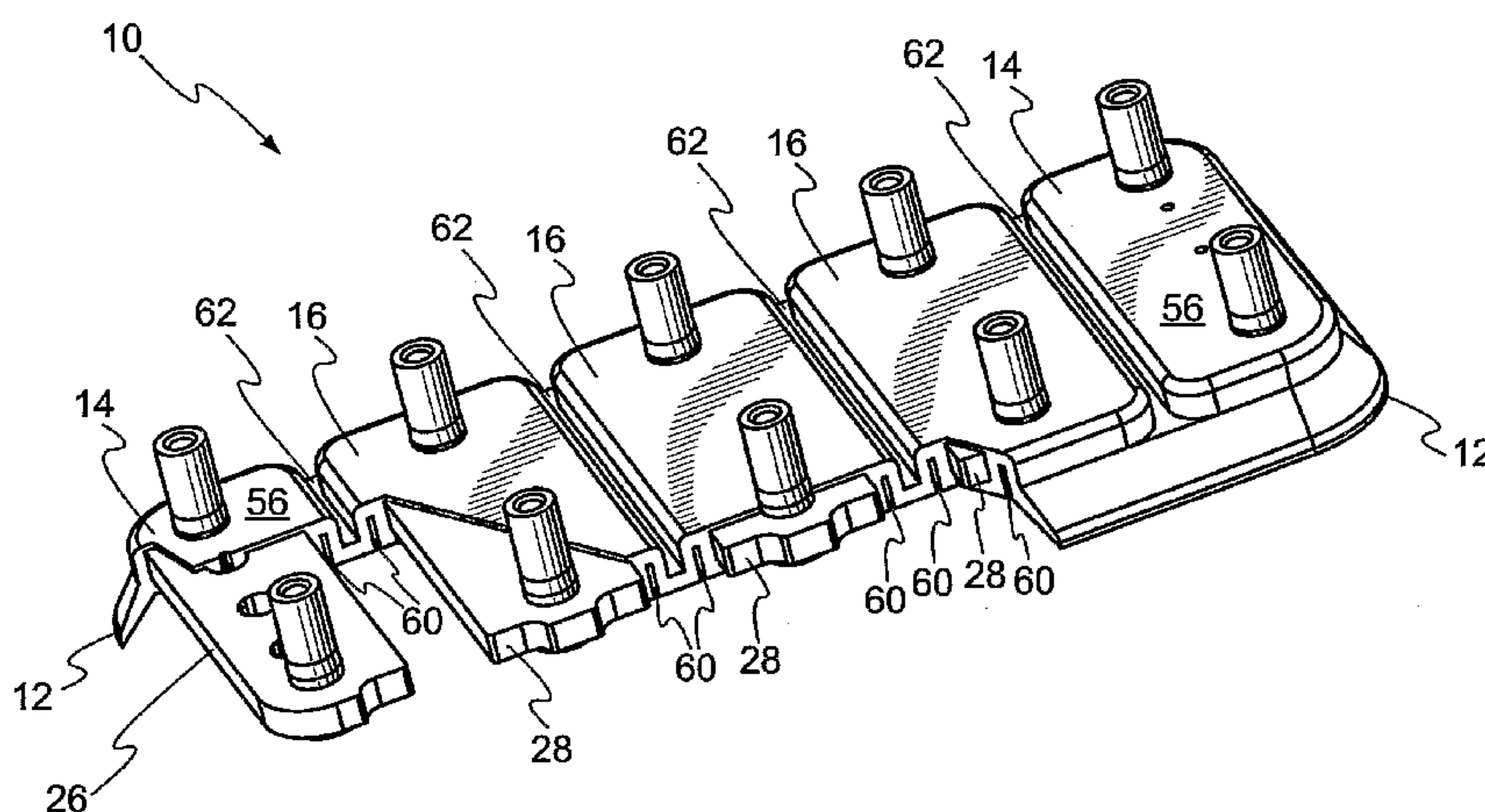

(57) Abstract: A conformal vacuum cup (10) provides a machine tool attachment fitting usable in a flexible-track drill system. Using multiple, independently articulated stiffeners (26, 28), the conformal vacuum cup conforms to the contour of complex aerospace structure surface shapes (70). The individual stiffeners (26, 28) are decoupled from each other to some extent by grooves (62) and slots (60) molded into resilient overmolding material to support long-axis curving. Spacing pins (18) employ a domed shape consonant with the elastic deformation of the workpiece surface (70) under load. The pins (18) employ a hard material to prevent particle embedment in use and to control position tolerance for drill heads and other tools traveling on the flexible track. Partial holes (24, 54) in each vacuum cup (10) are blocked by diaphragms (58). Interconnection from a vacuum system manifold to the vacuum cups can be realized by penetrating the diaphragms (58) and inserting barbed fittings (64) connected by vacuum tubing (68).

WO 2006/043983 A3

**CONFORMAL VACUUM CUP APPARATUS AND METHOD FOR
REMOVABLY ATTACHING A RAIL TO A SURFACE OF A WORKPIECE**

FIELD OF THE INVENTION

5 **[0001]** The present invention relates generally to manufacturing tools and automation. More particularly, the present invention relates to attachment of rail-mounted machine tools to work surfaces.

BACKGROUND OF THE INVENTION

10 **[0002]** Portable, vacuum-cup-attached systems for drilling or fastening sections of aircraft fuselage or wing structures, as well as for other manufacturing operations, for other vehicle types, and for static structures, have been developed previously, but have generally been most practical for use only on workpiece areas where the contour is zero or very small in the longitudinal direction of the device. For example, some prior art vacuum cup systems
15 could be attached readily along the flight direction of a cylindrical or otherwise highly curved fuselage, particularly where the fuselage has a long, essentially straight extent (i.e., a contour near zero), but attaching such a system to the fuselage in the circumferential direction, or fore-and-aft along a curving wing rib, would tend sometimes to produce uncertain results.

[0003] Prior art systems that use small numbers of large vacuum cups have been
20 used, but have tended to be unable to conform smoothly to severe contours. Prior art systems with large numbers of small vacuum cups can follow a contour to some extent, but tend to be limited in the available retaining force by the necessity of having physical clearance around each vacuum cup, and by the limited available length-to-width ratio of an individual cup.

[0004] Prior art rail-mounted machine tool systems can possess the capability to
25 advance a tool attached to a rail using a motor and gear apparatus integrated with the tool. Measurement apparatus, likewise integrated with the tool, allows the position of the tool to be determined with considerable precision. Nonetheless, prior art systems tend to be limited in their ability to conform to generalized surfaces, being best suited to positioning along low-contour paths.

[0005] Accordingly, it would be desirable to provide a method and apparatus that provides attachment of a rail system that can conform to surfaces with comparatively large contour in the longitudinal direction of traversal by the rail system and by tools carried thereon.

5

SUMMARY OF THE INVENTION

[0006] The conformal vacuum cup described in some embodiments comprises a resilient cup member having a series of rigid stiffener elements oriented next to each other along the longitudinal axis of a rail system. A rail can be supported by attachment to the stiffener elements. The stiffener elements can be spaced away from the rail, in a representative
10 embodiment, using standoff pins attached to the stiffener elements and to the rail. Between each pair of stiffener elements is a gap sufficient to allow the rail to flex over a comparatively sharply curved contour without interference. A group of stiffener elements assembled in a mold can be overmolded with an elastomeric material such as urethane, which overmolding encloses all of the stiffener elements and adds a circumferential lip to establish the vacuum cup. The vacuum cup
15 so formed can have kerf shapes formed into the gaps between adjacent stiffener elements to permit substantial motion between the stiffener elements despite the presence of the overmolded elastomer. The above standoff pins can protrude from top and/or bottom surfaces of the overmolded elastomer.

[0007] In another aspect, a vacuum cup for removable connection between a
20 conformable, tool-carrying rail and a rail-side surface of a workpiece comprises an inner surface of the vacuum cup, an outer surface of the vacuum cup, a plurality of resilient pads joined into a contiguous whole (wherein the area between each pad and the rail-side surface of the workpiece defines a zone), a plurality of stiffener elements (wherein at least one of the plurality of stiffening elements is embedded at least partially within each respective one of the pads, and
25 wherein the stiffener elements are attachable to the rail), and a resilient peripheral seal, joined to the pads and surrounding the periphery of all of the zones between the pads and the rail-side surface of the workpiece.

[0008] In still another aspect, a vacuum cup for removable connection between a conformable, tool-carrying rail and a rail-side surface of a workpiece comprises an inner surface of the vacuum cup, an outer surface of the vacuum cup, a plurality of resilient pads joined into a contiguous whole, wherein the area between each pad and the rail-side surface of the workpiece
5 defines a zone, a plurality of stiffener elements, wherein one of the plurality of stiffening elements is embedded at least partially within each of the pads, and wherein the stiffener elements are attachable to the rail, and a resilient peripheral seal, joined to the pads and surrounding the periphery of all of the zones between the pads and the rail-side surface of the workpiece, and a plurality of standoff pins attached to the rail, where at least one of one of the
10 standoff pins is attached to a respective one of each of the stiffener elements.

[0009] In still another aspect, an attachment between a rail with a longitudinal axis and a rail-side surface of the workpiece comprises means for stiffening a vacuum cup along an axis transverse to the longitudinal axis of the rail and parallel to the rail-side surface of the workpiece, means for removably sealing the stiffening means to the rail-side surface of the workpiece
15 against vacuum loss, means for rigidly positioning a point on the rail with respect to a point on the rail-side surface of the workpiece, and means for coupling a vacuum source to a spatial volume occupying all of a space between the means for sealing and the rail-side surface of the workpiece.

[0010] In yet another aspect, a method for removably attaching a rail with a longitudinal
20 axis to a rail-side surface of a workpiece comprises stiffening a vacuum cup along an axis transverse to the longitudinal axis of the rail and parallel to the rail-side surface of the workpiece, removably sealing a perimeter of the vacuum cup to the rail-side surface of the workpiece against vacuum loss, rigidly positioning a point on the rail with respect to a point on the rail-side surface of the workpiece, and coupling a vacuum source to a spatial volume occupying all of a
25 space between the vacuum cup and the rail-side surface of the workpiece.

[0011] There have thus been outlined, rather broadly, certain embodiments of the invention, in order that the detailed description thereof herein may be better understood, and in order that the present contribution to the art may be better appreciated. There are, of course,

additional embodiments of the invention that will be described below and which will form the subject matter of the claims appended hereto.

[0012] In this respect, before explaining at least one embodiment of the invention in detail, it is to be understood that the invention is not limited in its application to the details of construction and to the arrangements of the components set forth in the following description or
5 illustrated in the drawings. The invention is capable of embodiments in addition to those described and of being practiced and carried out in various ways. Also, it is to be understood that the phraseology and terminology employed herein, as well as the abstract, are for the purpose of description and should not be regarded as limiting.

10 [0013] As such, those skilled in the art will appreciate that the conception upon which this disclosure is based may be used readily as a basis for the designing of other structures, methods, and systems for carrying out the several purposes of the present invention. It is important, therefore, that the claims be regarded as including such equivalent constructions insofar as they do not depart from the spirit and scope of the present invention.

15

BRIEF DESCRIPTION OF THE DRAWINGS

[0014] FIG. 1 is a perspective view illustrating from beneath a fully compressed conformal vacuum cup according to a preferred embodiment of the invention.

20 [0015] FIG. 2 is an oblique view from above with cutaway of a conformal vacuum cup according to the embodiment of FIG. 1.

[0016] FIG. 3 is an exploded view of an end stiffener and associated standoff pins according to the embodiment of FIG. 1.

[0017] FIG. 4 is an exploded view of an intermediate stiffener and associated standoff pins according to the embodiment of FIG. 1.

25 [0018] FIG. 5 is a section view of a vacuum connection with an intact diaphragm.

[0019] FIG. 6 is a section view of a vacuum connection with a pierced diaphragm in which a barbed tubing coupling has been installed.

[0020] FIG. 7 is a side view with cutaway of a conformal vacuum cup installed on a rail and pressed onto a workpiece, according to the embodiment of FIG. 1.

[0021] FIG. 8 is a section view of a groove and kerfs separating two pads according to the embodiment of FIG. 1.

5 [0022] FIG. 9 is a section view of a groove without kerfs.

[0023] FIG. 10 is an oblique view from above of a conformal vacuum cup according to an alternative embodiment of the invention.

[0024] FIG. 11 is a side view of a multiplicity of conformal vacuum cups according to the alternative embodiment of FIG. 10, showing attachment to a rail and a curved workpiece.

10

DETAILED DESCRIPTION

[0025] Various embodiments in accordance with the present invention provide vacuum cup apparatus and methods for attachment of devices such as, for example, a rail system used in operations such as drilling series of holes, which holes may be needed for assembling screws or rivets through airplane sheet surfaces into underlying structures. Although described in the context of aircraft manufacturing, various embodiments can also be useful in other manufacturing industries. The invention will now be described with reference to the drawing figures, in which like reference numerals refer to like parts throughout.

[0026] FIG. 1 is an oblique bottom view that shows a fully compressed vacuum cup 10 according to an exemplary embodiment. The vacuum cup 10 has a peripheral sealing lip 12 that is shown deflected as it would be seen from below a transparent workpiece (a workpiece 70 is shown in FIGS. 7 and 11) when vacuum from an external vacuum system (shown in FIG. 10) has been applied to the volume between the cup 10 and the workpiece 70, and has caused outside air pressure to force the cup 10 against the workpiece 70. The exemplary vacuum cup 10 comprises two end pads 14 along with three intermediate pads 16. Each pad 14 or 16 comprises a stiffener (stiffeners 26 and 28 are shown in FIG. 2) encapsulated in the resilient material of the vacuum cup 10, and further comprises two standoff pins 18 with bottom ends 20 that can directly contact the workpiece when the cup 10 is compressed. The standoff pin tops 22 can be attached to a rail using

25

suitable fastenings (a rail 72 is shown in FIGS. 7 and 11). One or more partial holes 24 that are used to permit vacuum system attachment are shown in each end pad 14 and in more detail in FIGS. 5 and 6.

[0027] FIG. 2 is an oblique cutaway view of the vacuum cup 10 from above. Representative pads 14 and 16 are shown cut away to reveal an end pad stiffener 26 and intermediate pad stiffeners 28 within their respective pads 14 and 16. Similar stiffeners are fully shown in FIGS. 3 and 4.

[0028] FIG. 3 is an oblique exploded view showing an end stiffener 30 substantially similar to the corresponding stiffener 26 in FIG. 2. The stiffener 30 is shown with two standoff pins 18 oriented for insertion. Each of the exemplary standoff pins 18 in FIG. 3 has a pin top 22 with a chamfer 32 and a female thread 34 for attachment to a rail 72 (shown in FIGS. 7 and 11). A taper section 36 and an interference-fit section 38 on each standoff pin 18 can allow the pin 18 to be pressed substantially permanently into the corresponding hole 40. A shoulder 42 can provide an integral stop to allow the pin 18 to bear against the stiffener 26 or 30, with the pin bottom end 20 at a uniform distance from the bottom surface 44 of the stiffener 26 or 30. Three bores 46 in the end stiffener 30 can be used to provide passage for vacuum connection (shown in FIGS. 5 and 6).

[0029] FIG. 4 is an oblique exploded view showing an intermediate stiffener 48 substantially similar to the corresponding stiffener 28 in FIG. 2. The stiffener 48 is shown with two standoff pins 18 oriented for insertion. Each of the pins 18 in FIG. 4 has a pin top 22 with a chamfer 32 and a female thread 34 for attachment to a rail 72 (shown in FIGS. 7 and 11). A tapered section 36 and an interference-fit section 38 on each pin 18 can allow the pin 18 to be pressed essentially permanently into the corresponding hole 40. A shoulder 42 can provide a stop that allows the pin 18 to bear against the stiffener 48, with the pin bottom end 20 at a uniform distance from the bottom surface 50 of the stiffener 28 or 48.

[0030] Returning to FIG. 2, the sealing lip 12 is shown relaxed and deflected downward in its rest orientation. Inscribed around most of the perimeter of each of the pads 14 and 16 is a kerf or lower slot 60. An upper groove or slot 62 is present as well. The two kerfs 60 and one

groove 62 together provide some degree of decoupling between each two stiffeners 26, 28, 30, or 48, allowing the stiffeners 26, 28, 30, or 48 to draw together or move apart as flexed by the rail 72 (shown in FIGS. 7 and 11) to which they are fastened, and/or to twist relative to each other if so driven by the mounted curve profile of the rail 72.

5 [0031] FIG. 5 is a section through FIG. 1 at section line 5-5. This shows that the first partial hole 24 in the bottom face 52 of an end pad 14 aligns with a second partial hole 54 in the top face 56, shown in FIG 2, of the end pad 14. The two partial holes 24 and 54 are separated by a diaphragm 58, and may preferably be positioned within one of the bores 46 in the end stiffeners 26 and 30.

10 [0032] FIG. 6 is a section view of a barbed tubing coupling 64 inserted into a vacuum cup 10. After the diaphragm 58 has been pierced, for example using an ordinary sewing needle, a barbed coupling 64 of suitable size can be inserted into the second partial hole 54. The barbed coupling 64, preferably carrying a single barb on each end as shown, preferably passes through the pierced diaphragm 58 and uses the pierced diaphragm 58 as a locking element to retain the
15 barbed coupling 64. Various options may be preferable in some applications, such as using multiple-barb ends on the barbed coupling 64 or passing the barbed coupling 64 through the pierced diaphragm 58 and the first partial hole 24, although preferably not extending the barbed coupling 64 so far through the bore 46 as to extend beyond the pin bottom end 20 and contact the workpiece 70. The top of the barbed tubing coupling 64 is shown to be set at a right angle 66.
20 The right angle 66 shown may be preferable to allow a vacuum line 68 to deliver vacuum to the vacuum cup 10 without a sharp bend in the line 68. Other angles and other fitting styles may be preferable in some applications.

 [0033] Returning once more to FIG. 1, the multiplicity of partial holes 24 in the end pads 14 can be used to provide optional vacuum connections. In some embodiments it may be
25 preferable to plumb all vacuum cups 10 individually back to a common manifold. This can permit a manifold with valving to apply vacuum systematically, for example applying vacuum first to vacuum cups 10 located near mid rail, then sequentially activating cups outward toward both ends.

[0034] Experimentation has shown that for at least some combinations of materials and dimensions, a pierced diaphragm 58 may leak substantially no air when no barbed coupling 64 has been installed in it. This can allow the vacuum cup 10 in which the pierced diaphragm 58 exists to hold vacuum acceptably. By extension, a vacuum cup 10 may remain usable with
5 multiple diaphragms 58 that are unused but have been pierced.

[0035] Since the baseline configuration for the exemplary embodiment employs a common area below the entire vacuum cup 10, vacuum drawn at a first pierced partial hole 24 can be extended out through a second pierced partial hole 24 (as shown in FIG. 10). Another barbed tubing coupling 64 can be added to connect the vacuum source to a second vacuum cup
10 10 without using a manifold port at the vacuum source for every vacuum cup 10. Providing an ample number of partial holes 24 in the embodiment permits a variety of options for distributing vacuum in a rail-mounted machine tool system with a vacuum cups 10 of a single design. The availability of additional partial holes 24 can permit the addition of sensors, gauges, and the like as well as additional vacuum cups 10.

[0036] Continuing in FIG. 1, the standoff pins 18 are shown surrounded by the elastomer of the pads 14 and 16. The pin bottom ends 20 can be domed with a radius roughly equal to the elastic deformation of the workpiece 70 effected by the pressure stemming from the applied vacuum plus a portion of the weight of the rail-mounted drilling system. If the elastic deformation of the workpiece 70 can be shown to be negligible, then a satisfactory pin bottom
20 end 20 shape may be achievable with a flat face square to the workpiece and a smooth edge roundoff. The pin bottom end 20 shape, radius of curvature, and size may preferably be chosen to at least minimize scuffing or marring of the workpiece 70.

[0037] FIG. 7 is a side view with a partial cutaway, revealing the structure of a vacuum cup 10 pressed against a workpiece 70 and attached to a rail 72 with studs 74, nuts 76, and
25 washers 78. The lip 12 is flexed upward from its rest position as a result of application of vacuum. In FIG. 7, a flat workpiece 70 is contacted by the standoff pins 18, causing the rail 72 to assume a flat shape, parallel to the workpiece 70.

[0038] FIG. 8 is a section through the vacuum cup 10 of FIG. 1, in which the kerfs 60 and upper groove 62 are shown as they would be with a vacuum cup 10 positioned on a flat workpiece 70. Where the workpiece 70 surface is curved, the standoff pins 18 (shown in FIGS. 1 and 2) are drawn by the vacuum to conform to that curve, shifting the stiffeners 28 and 30, and causing the elastomer between the kerfs 60 and the upper groove 62 to flex. This flexure allows the vacuum cup 10 to conform to a workpiece 70 with a relatively sharp curvature, and thus to cause the rail 72 to so conform. Twist in the workpiece 70 can be accommodated as well, with the elastomer flexing as necessary.

[0039] FIG. 9 is a section through an alternative vacuum cup configuration retaining the upper groove 62 but without kerfs. This configuration may be preferable on some workpieces, for example where curvature is slight or nonexistent along the rail longitudinal axis.

[0040] Alternative methods for fastening standoff pins to a rail could include welding, brazing, and equivalent metallurgical bonding methods, as well as application of a flange to the top of each standoff pin, which flange could have multiple radially-arrayed holes for rivets or other fastenings. The stud 74, nut 76, and washer 78 of the exemplary embodiment can be replaced by other threaded fasteners, such as screws with or without washers, and can be prevented from loosening by application of antivibration materials, upset threads, and other technologies.

[0041] FIG. 10 is an oblique view of a conformal vacuum cup 10 according to another design. Here, the lip 12 is made wavy instead of straight-edged as in FIGS. 1-9. In the embodiment shown, the elastomeric material 80 does not surround the stiffeners 28 and 30 above an attachment shoulder 82. The embodiment shown has one inlet vacuum line 84 and one outlet vacuum line 86, with no provision for additional vacuum lines. In this embodiment, a fitting 88 is employed to seal to a threaded hole and connect to a vacuum hose 94 at an approximate right angle. FIG. 10 further shows in schematic form the use of a vacuum source 92 connected by a vacuum hose 94 to use the vacuum cup 10. In the embodiment shown, a second fitting 88 connects to a second vacuum hose 86 to carry vacuum to another vacuum cup 10 or to an accessory such as a gauge.

[0042] FIG. 11 shows multiple samples of the conformal vacuum cup 10 of FIG. 10 attached to a curved rail 72 using studs 74, nuts 76, and washers 78. Also shown is a convex-curved workpiece 70. The curvature of the rail 72 requires the flexing of the conformal vacuum cups 10 to accommodate the drawing together of the individual stiffeners 30 and 48 shown in
5 FIGS. 3 and 4.

[0043] The stiffeners 26, 28, 30, and 48 described herein can preferably be fabricated from a material with specific physical properties. One such desirable stiffener property is higher flexure resistance than the rail 72 and/or the workpiece 70, particularly in the thickness used. Another such desirable stiffener property is compatibility with insertion of pins 18, which
10 compatibility includes adequate malleability to permit pin 18 insertion and similarity in temperature coefficient of expansion to the pins 18. Another such desirable stiffener property is compatibility with the elastomeric overmolding material, which compatibility includes tolerance of the temperatures at which the molding takes place and chemical compatibility with the overmolding material. Typical materials likely to be suitable include various aluminum and
15 stainless steel alloys, fiber reinforced phenolics, engineering plastics such as PEEK®, and others.

[0044] Suitable elastomers for the vacuum cup overmolding material include a class of synthetic rubbers known generically as urethanes. Other classes of elastomers, such as vinyls, as well as other formable materials, may, like urethanes, have adequate ranges of durometer values and acceptable physical properties such as tear resistance for repeated use and may exhibit an
20 ability to withstand rough treatment. Urethanes in the preferred range of durometers can in some formulations exhibit a desirable ability to cling to surfaces, which ability may add to the positioning force of the vacuum cups 10. Vinyls may exhibit significantly lower cling than urethanes, which may be preferable in some embodiments. Other elastomers may likewise exhibit desirable combinations of attributes for specific uses.

[0045] Forcing air, such as from a compressor, through a vacuum cup system may allow
25 the cups to function as air bearings to make tool repositioning easier and quicker. Specific features such as lip shape, interface surface profile, elastomer material choice, and available air flow rate may inhibit or facilitate such use.

[0046] The many features and advantages of the invention are apparent from the detailed specification, and, thus, it is intended by the appended claims to cover all such features and advantages of the invention which fall within the true spirit and scope of the invention. Further, since numerous modifications and variations will readily occur to those skilled in the art, it is not
5 desired to limit the invention to the exact construction and operation illustrated and described, and, accordingly, all suitable modifications and equivalents may be resorted to that fall within the scope of the invention.

What is claimed is:

1. A vacuum cup for removable connection between a conformable, tool-carrying rail and a rail-side surface of a workpiece, comprising:

an inner surface of the vacuum cup;

5 an outer surface of the vacuum cup;

a plurality of pads comprising resilient material and joined into a contiguous whole, wherein the area between each pad and the rail-side surface of the workpiece defines a zone;

10 a plurality of stiffener elements, wherein at least one of said plurality of stiffening elements is embedded at least partially within each respective one of said pads, and wherein said stiffener elements are attachable to the rail; and

a resilient peripheral seal, joined to said pads and surrounding the periphery of all of the zones between said pads and the rail-side surface of the workpiece.

15 2. The vacuum cup of claim 1, further comprising a groove between adjacent pads, wherein said groove provides a flexible hinge between adjacent stiffeners.

3. The vacuum cup of claim 2, further comprising at least one kerf comprising a slot between said pad and said groove.

20 4. The vacuum cup of claim 3, wherein said groove intrudes into the volume of resilient material from the outer surface of the vacuum cup, and wherein said kerf intrudes into the volume of resilient material from the inner surface of the vacuum cup.

5. The vacuum cup of claim 1, further comprising:

25 a vacuum chamber occupying a volume defined between said inner surface of the vacuum cup and the workpiece, said vacuum chamber communicating between all zones surrounded by said peripheral seal; and

an inlet portal penetrating the vacuum cup, through which a fluid can be withdrawn from or injected into said vacuum chamber.

6. The vacuum cup of claim 1, wherein each of said plurality of stiffener elements further
5 comprises:

a longer axis of said stiffener element;

a shorter axis at right angles to said longer axis of said stiffener element;

a third axis of said stiffener element; and

a resistance to flexure by said stiffener element about each of the first axis and second
10 axis that exceeds the resistance to flexure of at least one of the rail and the workpiece about those axes, where the vacuum cup is configured for use so that the longer axis of said stiffener element is perpendicular to a longer axis of the rail and parallel to the rail-side surface of the workpiece, said shorter axis of said stiffener element is parallel to the longer axis of the rail and to the rail-side surface of the workpiece, and said third axis is perpendicular to the rail-side surface of the
15 workpiece.

7. The vacuum cup of claim 1, wherein said plurality of pads further comprises a first end pad and a second end pad.

8. The vacuum cup of claim 7, wherein said first end pad is provided with at least one
20 penetrating hole.

9. The vacuum cup of claim 7, wherein said second end pad is provided with at least one penetrating hole.

25

10. The vacuum cup of claim 7, wherein said plurality of pads further comprises at least one intermediate pad positioned between said first end pad and said second end pad.

11. The vacuum cup of claim 1, wherein said peripheral seal further comprises a contact lip, wherein said contact lip is configured to engage in uninterrupted contact with the workpiece, and wherein said contact lip surrounds said plurality of pads.
- 5 12. The vacuum cup of claim 1, further comprising an attachment force between the rail and the rail-side surface of the workpiece that results from application of vacuum to the vacuum cup while said contact lip establishes continuous contact between the rail and the rail-side surface of the workpiece.
- 10 13. The vacuum cup of claim 6, wherein said inlet portal further comprises:
an inlet hole passing through said first end stiffener element;
a coating of resilient material, one of integral with and bonded to said peripheral seal, of sufficient thickness to provide a vacuum barrier at said inlet hole; and
a partial inlet penetration of said coating at said inlet hole, where said coating retains
15 sufficient strength at said partial inlet penetration to provide a vacuum barrier to the vacuum employed in establishing said attaching force.
14. The vacuum cup of claim 13, wherein said inlet portal further comprises:
an inlet piercing through said partial inlet penetration; and
20 a barbed tubular inlet fluid fitting inserted into said inlet piercing, where said barbed inlet fitting deforms said coating of resilient material and joins to said coating of resilient material sufficiently to establish a substantially continuous vacuum seal at said inlet piercing.
15. The vacuum cup of claim 13, wherein said inlet portal further comprises:
25 an inlet piercing through said partial inlet penetration; and
a barbed tubular inlet fluid fitting inserted into said inlet piercing, where said pierced inlet penetration closes behind a barb on said barbed inlet fitting sufficiently to reinforce a

continuous vacuum seal at said inlet piercing established by insertion of said barbed inlet fitting into said pierced inlet penetration.

16. The vacuum cup of claim 13, wherein said inlet portal further comprises:

- 5 a second partial inlet penetration;
a second inlet piercing through said second partial inlet penetration; and
one of a reclosure of said second inlet piercing sufficient to permit the vacuum cup to hold an effective vacuum seal without inserting a fitting into said second inlet piercing, insertion of a second barbed tubular inlet penetration fitting for communication of a vacuum to an
10 additional vacuum cup, and attachment of a vacuum-driven accessory device to the vacuum cup.

17. The vacuum cup of claim 1, further comprising:

an outlet portal, further comprising:

- 15 an outlet hole passing through said stiffener element;
a coating of resilient material, one of integral with and bonded to said peripheral seal, of sufficient thickness to provide a vacuum barrier at said outlet hole;
a partial outlet penetration of said coating at said outlet hole, where said coating retains sufficient strength at said partial outlet penetration to provide a vacuum barrier;
20 an outlet piercing through said partial outlet penetration; and
a barbed tubular outlet fluid fitting inserted into said outlet piercing, where said barbed outlet fitting deforms said coating of resilient material and joins to said coating of resilient material sufficiently to establish a continuous vacuum seal at said outlet piercing.

25

18. The vacuum cup of claim 17, wherein said outlet portal further comprises a flow path through which a gas flow from said inlet portal flows to at least one of an additional vacuum cup, a sensor, and a gauge.

19. The vacuum cup of claim 1, wherein said resilient material comprises one of a urethane, a vinyl, a non-urethane, non-vinyl elastomer, and a blend of elastomers.
- 5 20. A vacuum cup for removable connection between a conformable, tool-carrying rail and a rail-side surface of a workpiece, comprising:
- an inner surface of the vacuum cup;
 - an outer surface of the vacuum cup;
 - a plurality of pads comprising resilient material and joined into a contiguous whole,
- 10 wherein the area between each pad and the rail-side surface of the workpiece defines a zone;
- a plurality of stiffener elements, wherein one of said plurality of stiffening elements is embedded at least partially within each of said pads, and wherein said stiffener elements are attachable to the rail; and
 - a resilient peripheral seal, joined to said pads and surrounding the periphery of all of the
- 15 zones between said pads and the rail-side surface of the workpiece; and
- a plurality of standoff pins attached to the rail, where at least one of said standoff pins is attached to a respective one of each of said stiffener elements.
21. The vacuum cup of claim 20, wherein at least one end of each of said plurality of standoff
- 20 pins passes through said peripheral seal.
22. The vacuum cup of claim 20, wherein said plurality of standoff pins further comprise a workpiece-side end and a rail-side end.
- 25 23. The vacuum cup of claim 22, wherein said workpiece-side end of said standoff pin further comprises a domed face.

24. The vacuum cup of claim 22, wherein said workpiece-side end of each of said plurality of standoff pins further comprises a substance of a hardness sufficient to permit said workpiece-side ends of said pins to resist embedment of contaminants when subjected to said attaching force.
- 5 25. The vacuum cup of claim 22, wherein said domed face further comprises a radius of curvature compatible with a limit of elastic deformation of said workpiece when subjected to said attaching force.
- 10 26. The vacuum cup of claim 22, wherein said rail-side end of said standoff pin further comprises a joining configuration compatible with attachment of said standoff pin to said rail.
27. The vacuum cup of claim 26, wherein said joining configuration further comprises a female screw thread.
- 15 28. The vacuum cup of claim 26, wherein said joining configuration further comprises a male screw thread.
29. The vacuum cup of claim 26, wherein said joining configuration further comprises a hole pattern for riveting.
- 20 30. The vacuum cup of claim 26, wherein said joining configuration further comprises a plate for one of welding, brazing, and soldering.
31. The vacuum cup of claim 26, wherein said joining configuration further comprises a bayonet locking fixture.
- 25 32. An attachment between a rail with a longitudinal axis and a rail-side surface of the workpiece, comprising:

means for stiffening a vacuum cup along an axis transverse to the longitudinal axis of the rail and parallel to the rail-side surface of the workpiece;

means for removably sealing said stiffening means to the rail-side surface of the workpiece against vacuum loss;

5 means for rigidly positioning a point on the rail with respect to a point on the rail-side surface of the workpiece; and

means for coupling a vacuum source to a spatial volume occupying all of a space between said means for sealing and the rail-side surface of the workpiece.

10 33. The attachment of claim 32, wherein said attachment further comprises:

means for separating by a substantially uniform gap adjacent surfaces of proximal means for stiffening;

means for sealing against vacuum leakage adjacent surfaces established by said means for separating; and

15 means for dynamically varying dimensions in said means for separating while preserving the function of said means for sealing.

34. A method for removably attaching a rail with a longitudinal axis to a rail-side surface of a workpiece, comprising:

20 stiffening a vacuum cup along an axis transverse to the longitudinal axis of the rail and parallel to the rail-side surface of the workpiece;

removably sealing a perimeter of the vacuum cup to the rail-side surface of the workpiece against vacuum loss;

25 rigidly positioning a point on the rail with respect to a point on the rail-side surface of the workpiece; and

coupling a vacuum source to a spatial volume occupying all of a space between the vacuum cup and the rail-side surface of the workpiece.

35. The method for attaching a rail with a longitudinal axis to a rail-side surface of a workpiece of claim 34, further comprising:

separating by a substantially uniform gap adjacent stiffened pads from each other;

sealing against vacuum leakage adjacent pads separated from each other; and

5 dynamically varying a distance and angle of separation between separated pads while maintaining the sealing function.

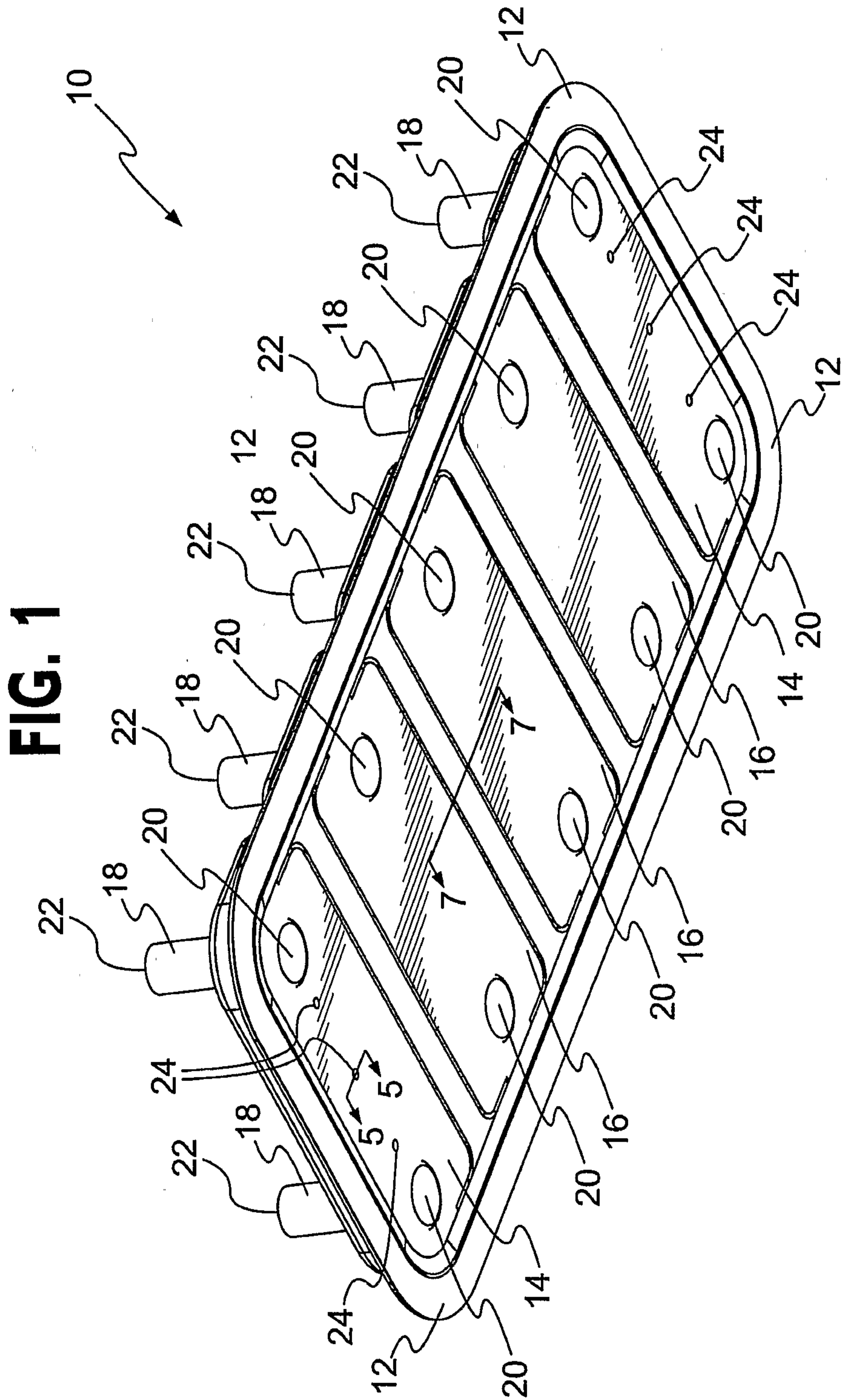
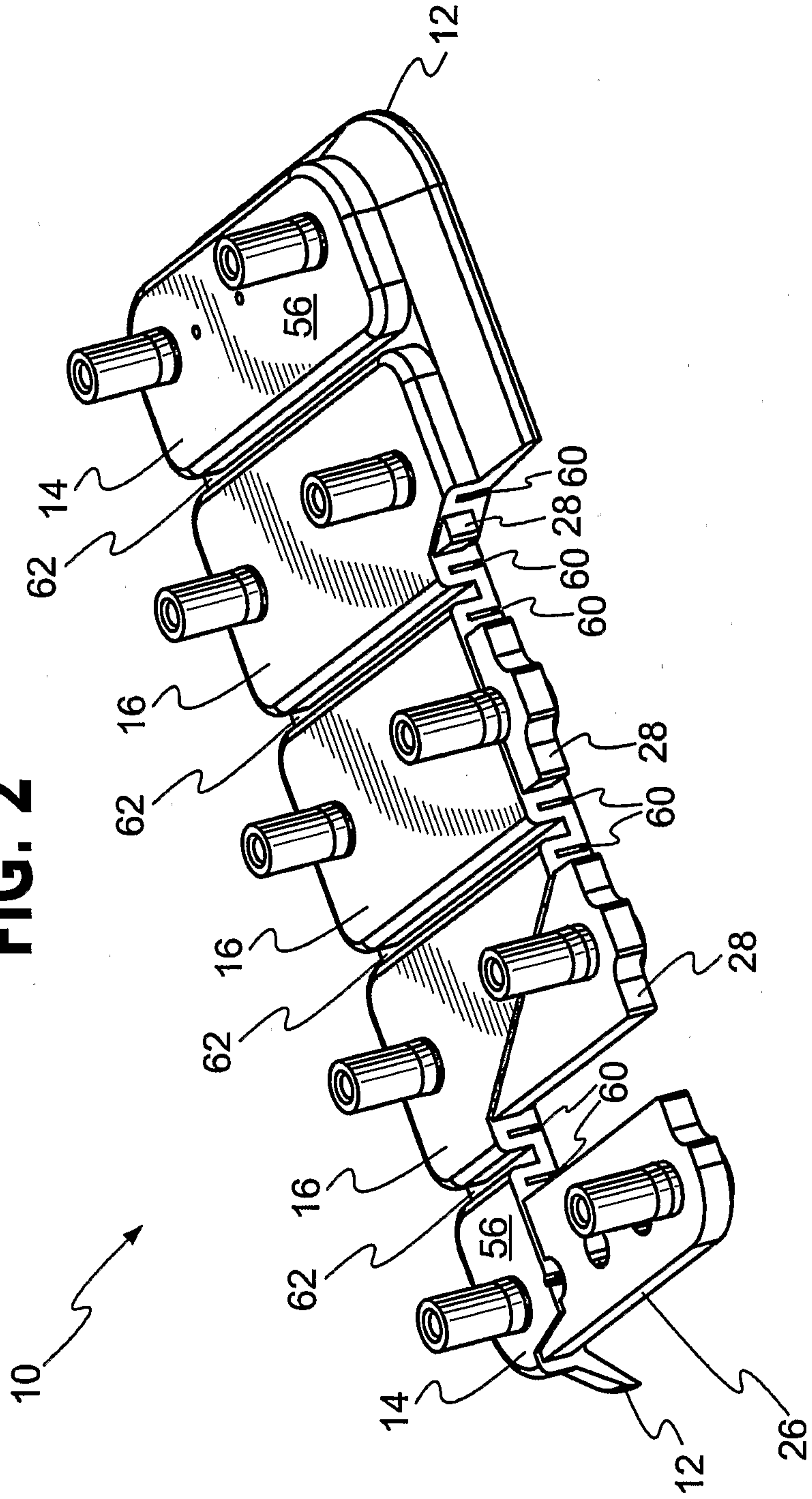

FIG. 2



3/8

FIG. 4

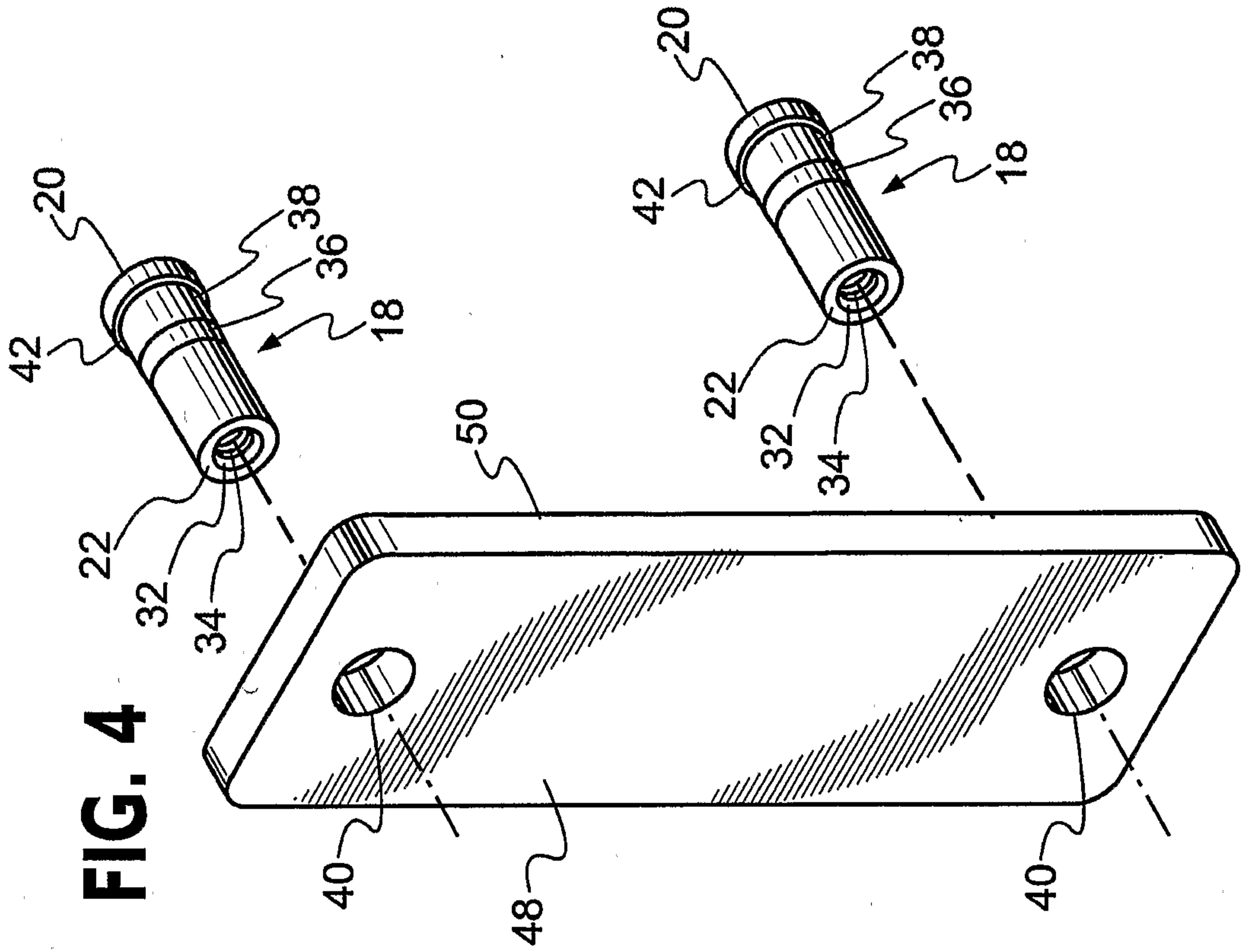
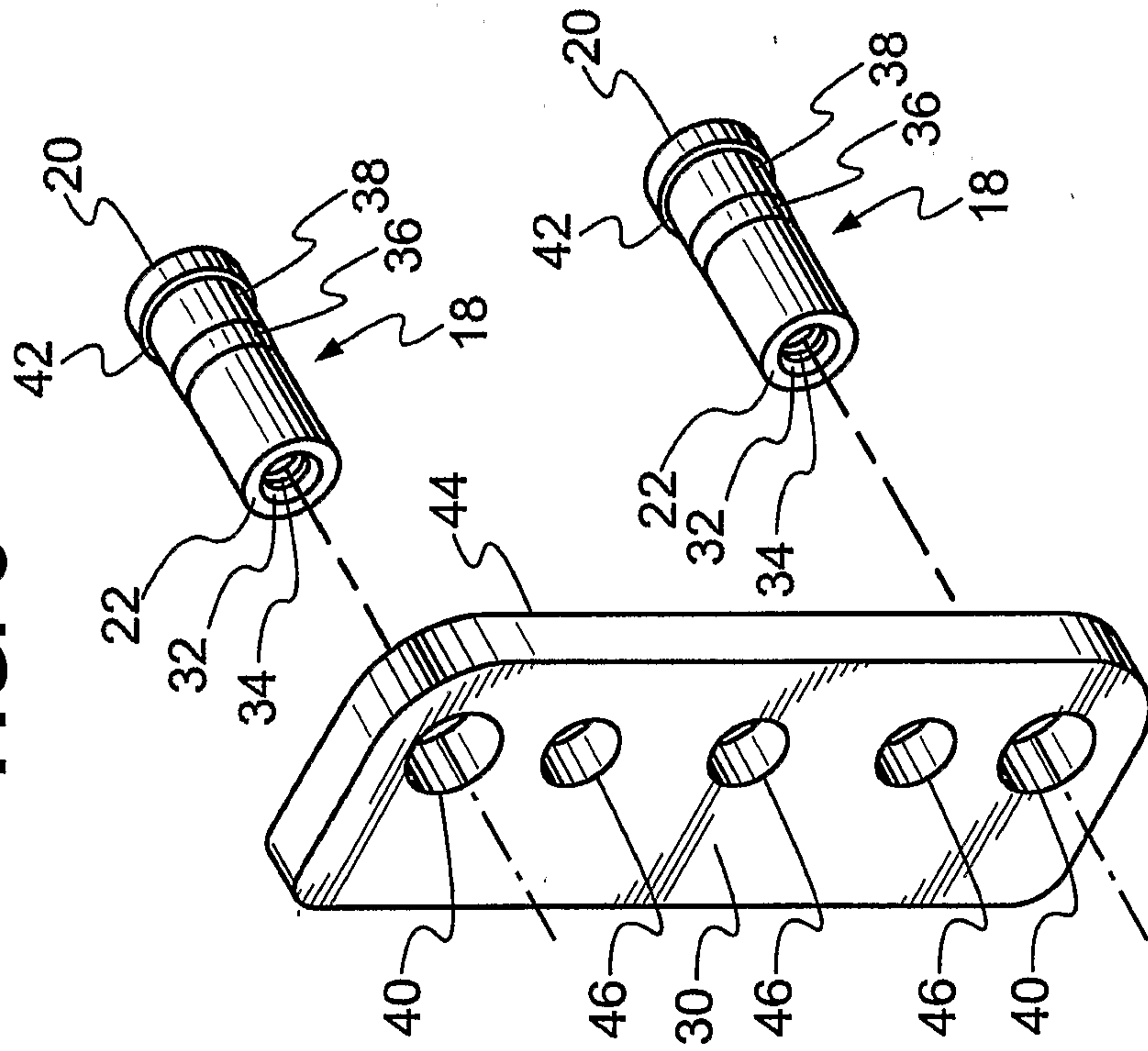

FIG. 3



4/8

FIG. 6

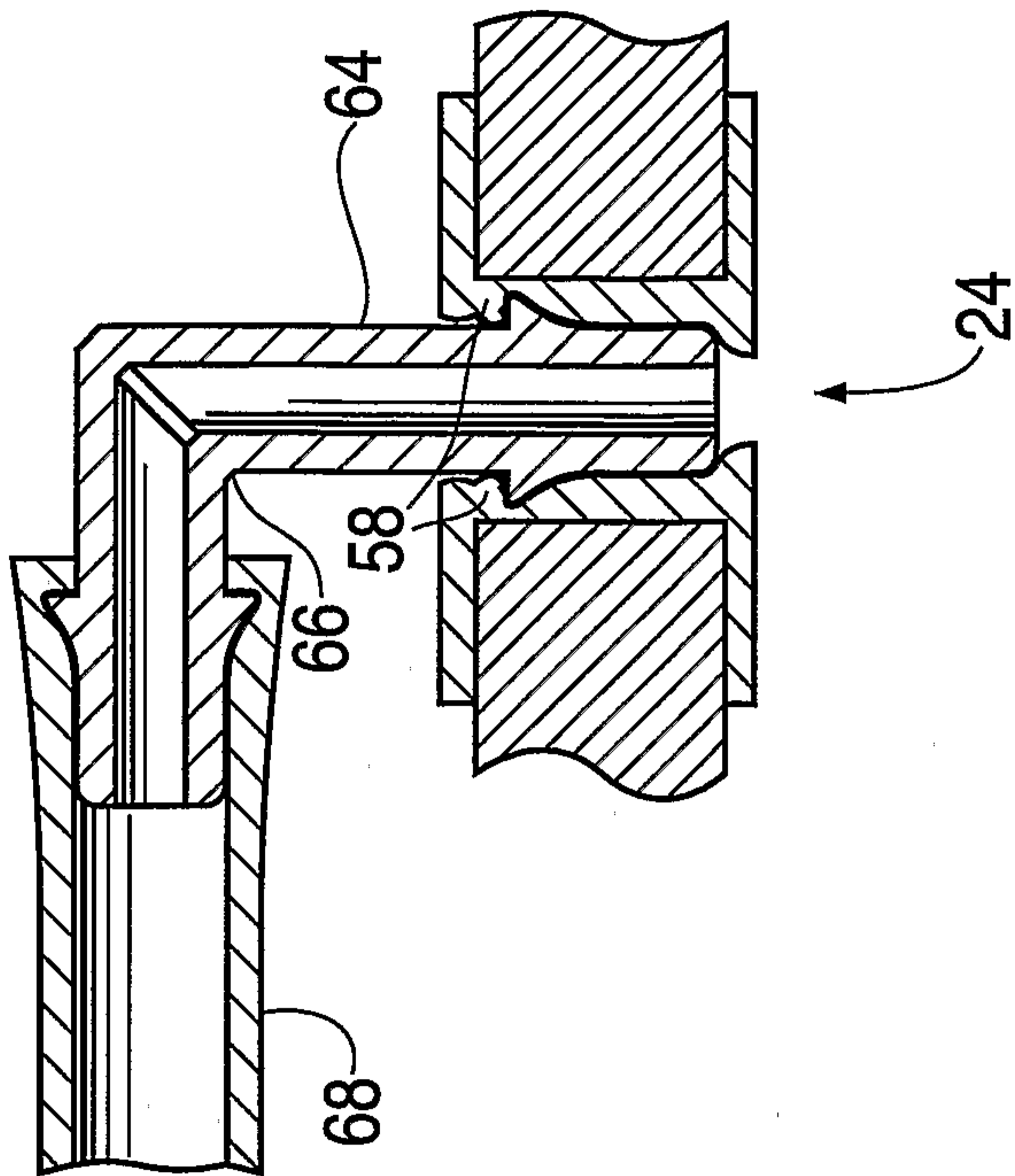

FIG. 5

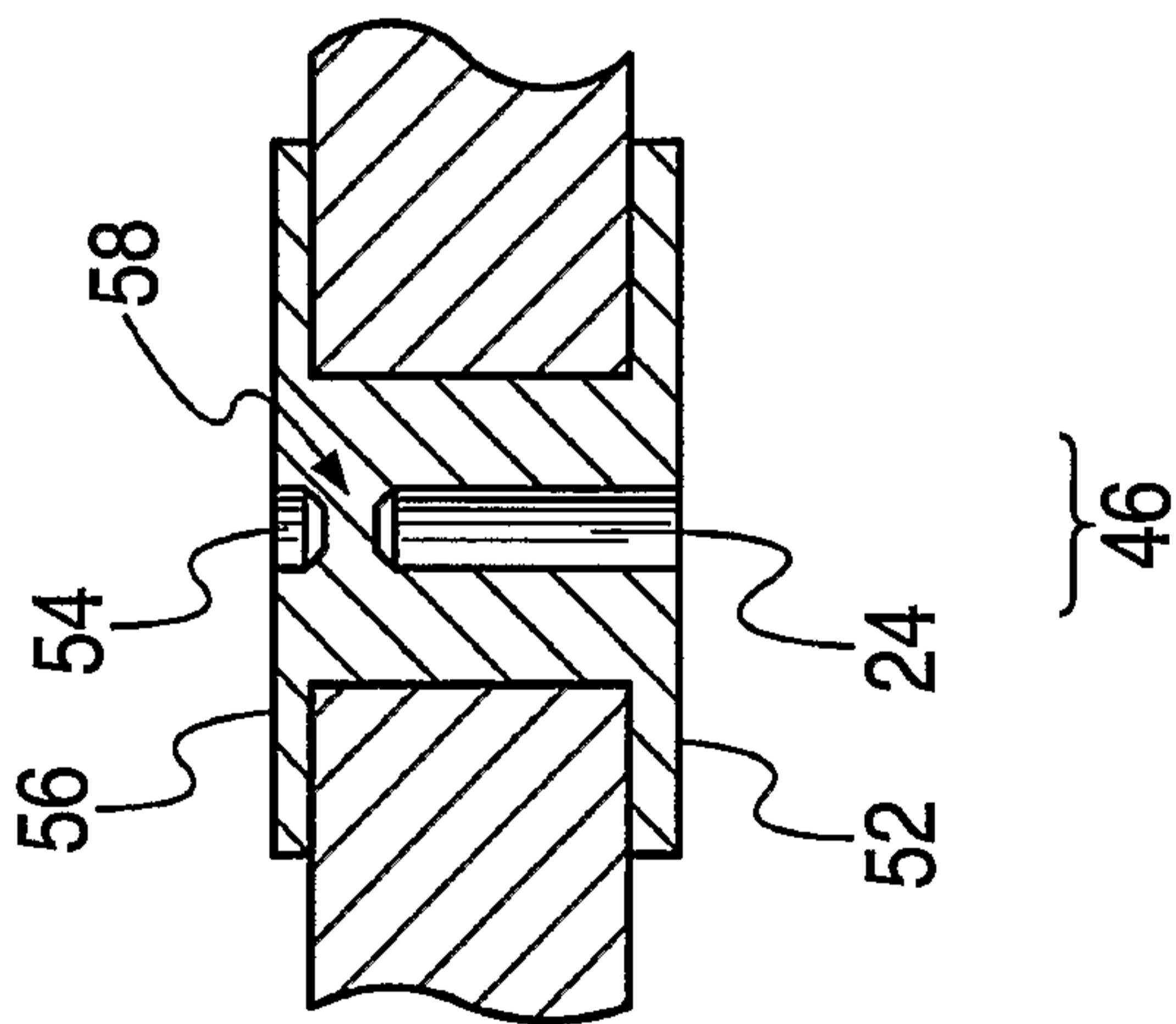
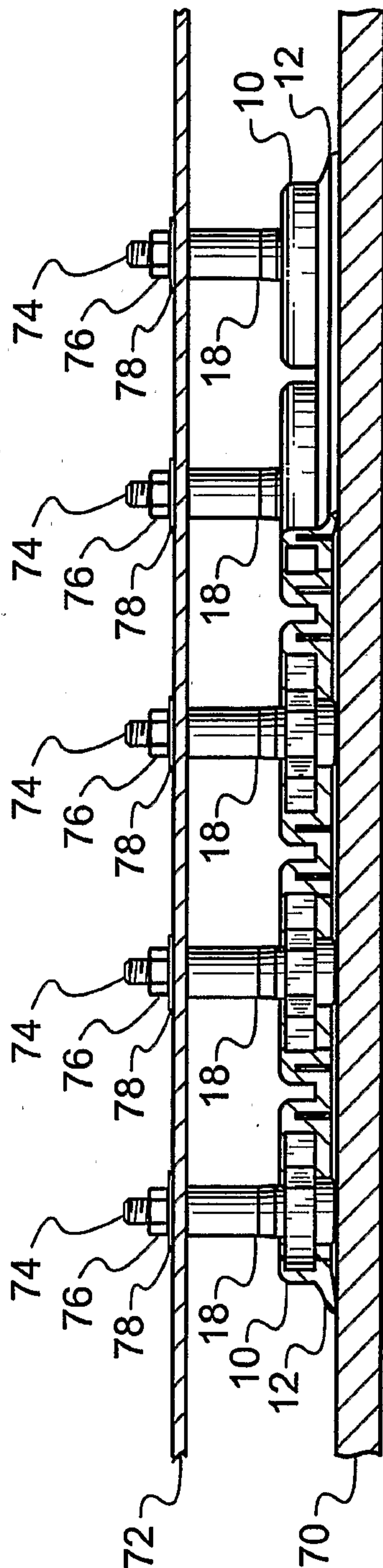
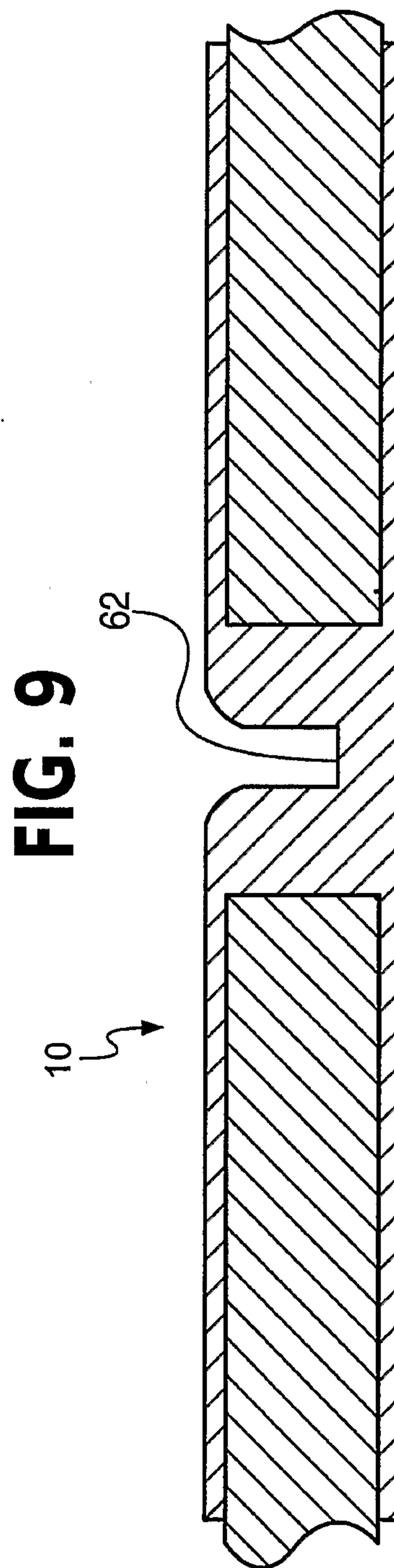
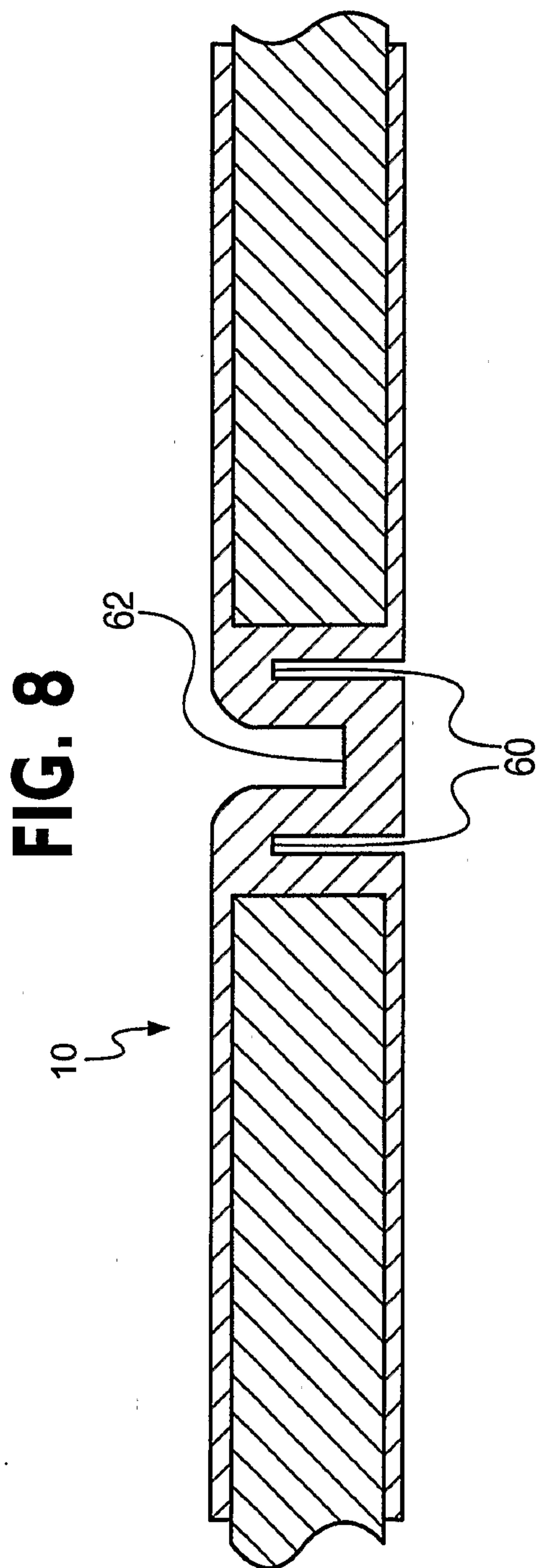

FIG. 7





7/8

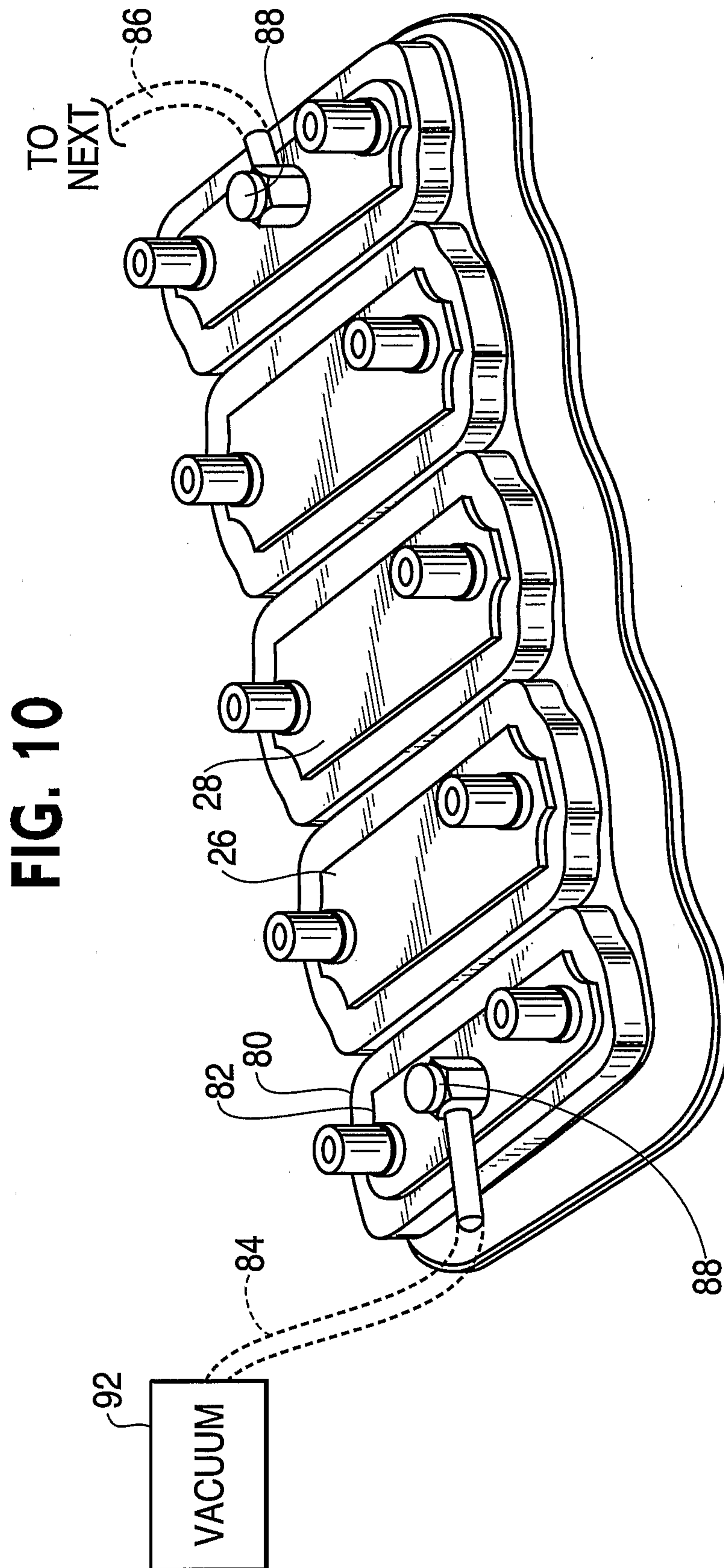

FIG. 10

