

1,360,236.

J. S. McCHESENEY,
WIRE TYING APPLIANCE.
APPLICATION FILED NOV. 13, 1916.

Patented Nov. 23, 1920.
3 SHEETS—SHEET 1.

Fig. 1.

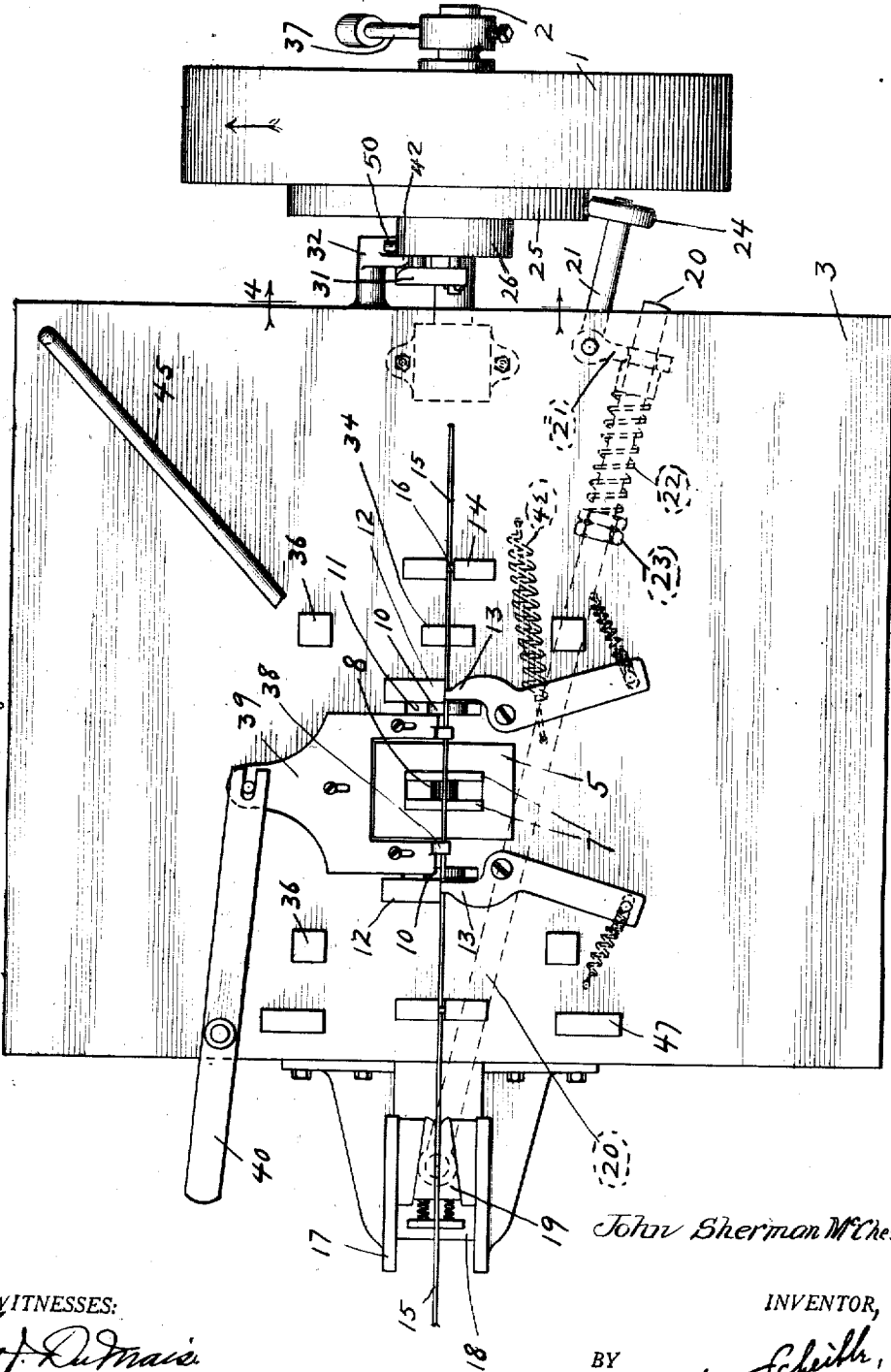

John Sherman McClesney

WITNESSES:

Leo Putman
W. K. Olson

INVENTOR,

BY

Albert Scheidt
ATTORNEY.

1,360,236.

J. S. McCHESNEY.
WIRE TYING APPLIANCE.
APPLICATION FILED NOV. 13, 1916.

Patented Nov. 23, 1920.
3 SHEETS—SHEET 2.

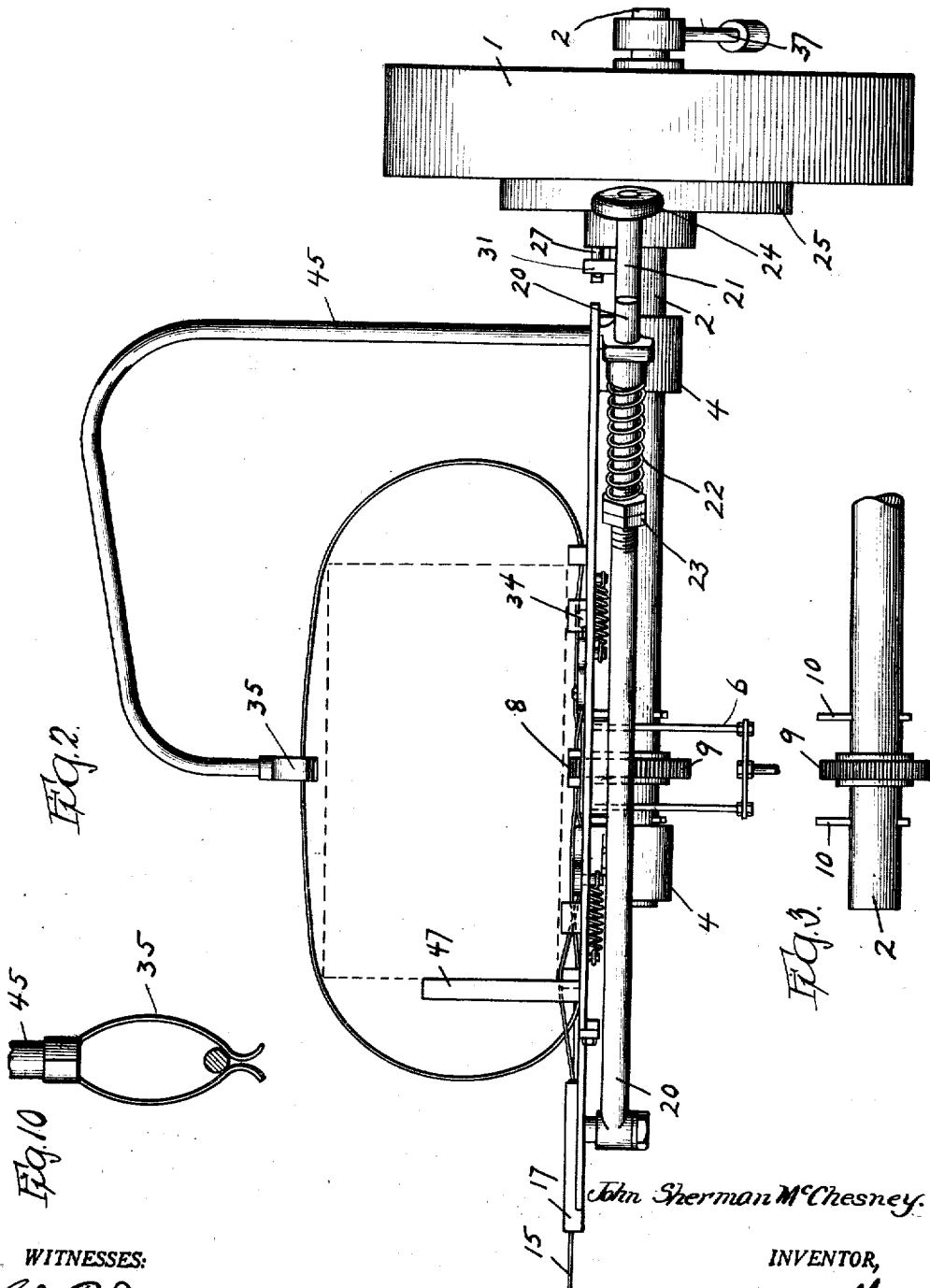

WITNESSES:
Conf. D. Davis
W. K. Olen

John Sherman McChesney.
 INVENTOR,
 BY *Albert Schick*,
 ATTORNEY.

1,360,236.

J. S. McCHESNEY,
WIRE TYING APPLIANCE,
APPLICATION FILED NOV. 13, 1916.

Patented Nov. 23, 1920.
3 SHEETS—SHEET 3.

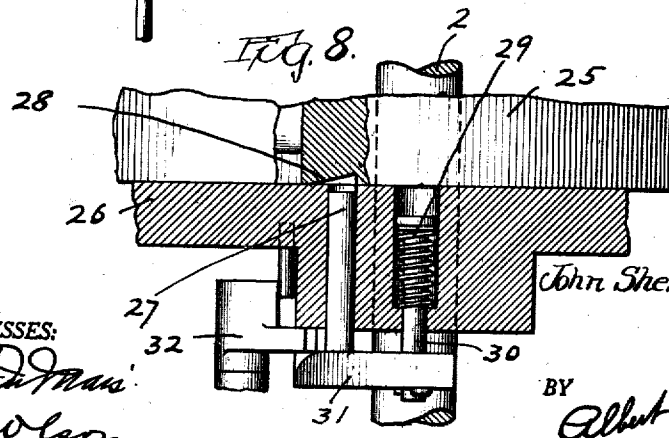
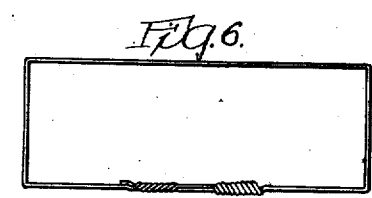
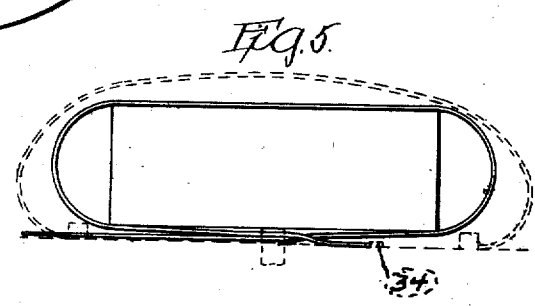
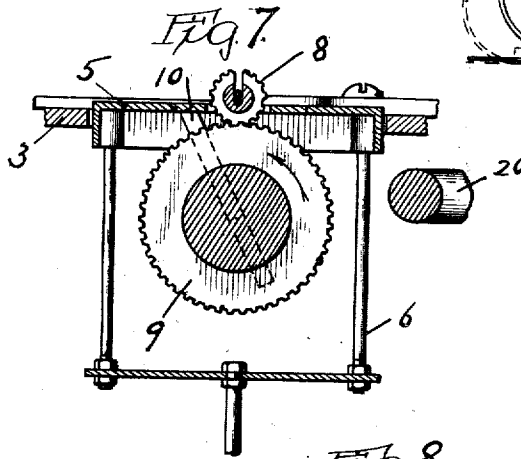
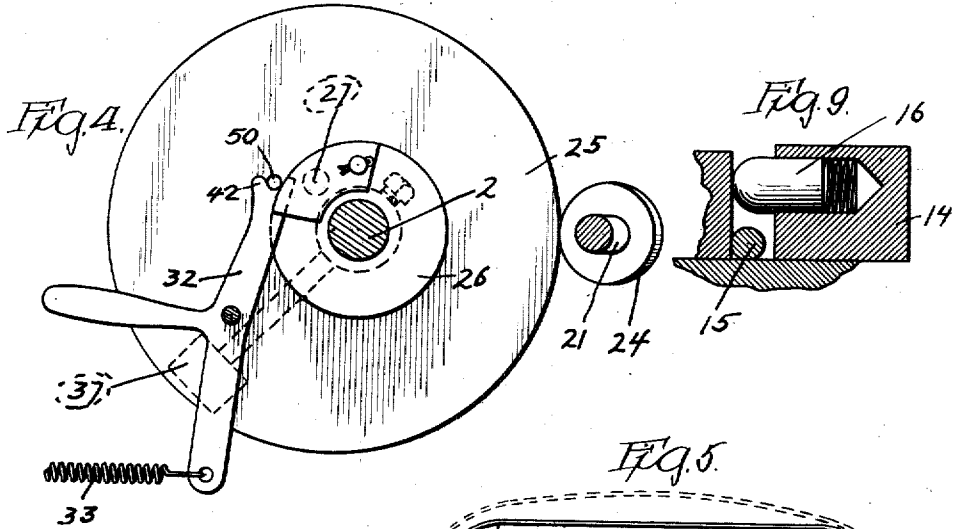

WITNESSES:
John Sherman McChesney
W. T. O'Leary

John Sherman McChesney
INVENTOR,
BY *Albert Scheidt*,
ATTORNEY.

UNITED STATES PATENT OFFICE.

JOHN SHERMAN McCHESNEY, OF CHICAGO, ILLINOIS, ASSIGNOR TO J. S. McCHESNEY & CO., OF CHICAGO, ILLINOIS, A CORPORATION OF ILLINOIS.

WIRE-TYING APPLIANCE.

1,360,236.

Specification of Letters Patent. Patented Nov. 23, 1920.

Application filed November 13, 1916. Serial No. 130,941.

To all whom it may concern:

Be it known that I, JOHN SHERMAN McCHESNEY, citizen of the United States, residing at Chicago, Illinois, have invented certain new and useful Improvements in Wire-Tying Appliances; and I do hereby declare the following to be a full, clear, and exact description of the invention, such as will enable others skilled in the art to which it appertains to make and use the same.

My invention relates to packaging, and more particularly to means for rapidly, neatly and effectively using wire for banding or tying boxes, lumber, shingles, laths, pipes, or other objects. In using wire for such purposes, it has been customary heretofore to start with a cut length of wire and to intertwist the free ends of the wire with pliers or the like, thereby leaving an unsightly projecting portion composed of the intertwisted ends and apt to catch on other objects adjacent to the one around which the tie was formed. The difficulties of producing a neat tie, of disposing the intertwisted ends so that they would not catch on other objects, of manually tensioning the wire around the package, and of avoiding a waste in estimating the length of wire required in each instance, have all mitigated against the use of wire for the general purposes mentioned, although wire has been admittedly cheaper than cordage of the same strength.

To overcome these difficulties, my invention provides a machine which uses the wire direct from the coil or reel, and which automatically compensates for variations in the periphery of the object packaged, and which cuts off the wire when the tie is being finished, thereby reducing the waste to a minimum; to intertwist each end of the wire tie with a portion of the tie spaced from the other end, thereby affording a pair of twists adapted to lie close to the package, to hold the initial wire loop in convenient position for inserting the desired object through it, to draw the wire around the object at the desired tension and to avoid overstraining it, to automatically release the wire loop from its supports during the tensioning, to start the twisting automatically when the desired tension of the wire is reached; to continue the twisting after the ends of the

wire have been severed, so as to turn the free ends of the twists toward the interior of the package; to provide a machine for this purpose in which certain parts may easily be thrown into action; to provide for an easy and rapid manual manipulation of the wire parts before the mechanically driven elements are set into operation, and to insure a stopping of certain of the elements in a position enabling an instant removal of the tied package and a ready placing of the next wire portion; to provide means for holding the object which is to be packaged, and means for preventing overlapping portions of the wire loop from snapping out of their proper positions before the intertwisting is started; and to provide means for raising the wire-tied object clear of the mechanism. Other objects will appear from the following specification and from the accompanying drawings, in which—

Figure 1 is a plan view of a machine embodying my invention, with portions of wire loop and of the loop-support cut away.

Figure 2 is a side view of the machine.

Figure 3 is a fragmentary elevation of the shaft of the machine, showing the gear and cutters mounted on it.

Figure 4 is an enlarged view showing portions of the clutch mechanism and of the cam arrangement for operating the tensioning of the wire taken on the line 4-4 of Figure 1.

Figure 5 shows the position of the wire loop with respect to a package just before the machine begins tensioning the wire; also, in dotted lines, the initial size of the wire loop.

Figure 6 shows the finished wire band.

Figure 7 is an enlarged section through the gear of Figure 1, showing the wire-twisting pinion and parts adjacent to the same.

Figure 8 is an enlarged fragmentary view, partially in section showing the clutch mechanism.

Figure 9 is an enlarged fragmentary view of one of the latches which initially hold the lower portions of the wire loop in position.

Figure 10 is an enlarged front elevation of the clip which initially supports the upper portion of the wire loop.

In the embodiments of the drawings, my

appliance is shown in the form of a power-driven machine having a continuously rotating pulley 1 loosely mounted on a shaft 2 which shaft extends horizontally under a table 3 through bearings 4. The table 3 has an aperture (here shown as rectangular) through which a lifter frame 5 projects, this frame being movable by means of lifting fork 6 shown in Fig. 2. Disposed within the frame 5 and normally projecting above it are guides 7, and a pinion 8 floatingly disposed between these guides and meshing with a spur gear 9 fast upon the shaft 2. The pinion 8 is equipped with a slot slightly wider than the diameter of the wire which is to be used on the machine, which slot extends (preferably radially) somewhat beyond the axis of the pinion, there being aligned slots of larger diameter in the guides 7. The shaft 2 also carries cutters 10 adapted during a certain part of each revolution of this shaft to project and operate through slots 11 in the table, the cutters being of such length that the uppermost portions of their paths will be substantially in line with the axis of the floating pinion 8. Mounted at the farther sides of the slots 11 from said pinion are pairs of spring jaws, each consisting of a fixed jaw 12 and a spring-actuated pivoted jaw 13, the tip of each pivoted jaw being so disposed with respect to its pivot as to resist the movement toward the pinion 8 of a wire extending from the slot in said pinion to the said jaw. Still further to each side of the pinion 8 than the said spring clamps are spring clips 14, each desirably arranged as in Fig. 9 for holding a portion of the wire 15 under it, but permitting the spring plunger 16 to retract and release the said wire upon a sufficiently strong upward pull on the wire.

At the end opposite the pulley 1, the table 3 carries guideways 17 for a slide 18 carrying a pair of spring-pressed wedge jaws 19. The slide 18 is pivoted to one end of a thrust rod 20 extending under the table and projecting at its other end loosely through one arm of a bell-crank lever 21 pivoted to the table. This lever is connected to the rod 20 by a compression spring 22, the tension of which may be adjusted by nuts 23, and the other end of the lever carries a roller 24 bearing against the periphery of a cam 25 which is fast upon the pulley 1 and preferably integral with the latter. Fast upon the shaft 2 and adjacent to the cam 25 is a clutch body 26 carrying a plunger 27 adapted to project beyond the body 26 and into engagement with a ratchet formation 28 on the cam 25, this plunger being continuously urged toward its said engaging position by a spring 29 acting on a piston 30 which piston is connected to the plunger 27 by a strap 31. The strap 31 preferably

is a portion of a ring concentric with the shaft 2, and has one end tapered, so that the tip of a release lever 32 may enter between this tip and the clutch body 26, as shown in Fig. 8, thereby moving the plunger 27 out of its said cam-engaging position. The lever 32 is preferably continuously urged in one direction by a spring 33, and has at its tapered tip a shoulder (shown in Fig. 4) adapted to engage one end of the strap 31 so as to stop a further rotation of the clutch body 26 after the tip of the lever 32 has entered between this body and the end of the strap 31.

In operation, wire is drawn from a coil or reel (suitably disposed to the left of the machine in Fig. 2 but not shown in the drawing) and is formed into a loop having two of the lower portions overlapped and both slipped into the slot in the pinion 8, the portion leading from the reel or coil being lowermost in the said slot but being then kept above the free end of the wire, which free end is butted against a low stop 34, as shown in Figs. 2 and 5. When thus forming the wire loop by hand, the top of the loop is snapped between the jaws of a spring clip 35 supported by a gooseneck 45 mounted on the table 3, this gooseneck being so shaped as to bring the clip 35 directly above the pinion 8. Other portions of the wire loop are snapped under the latches 14, and the free end portion of the wire is gripped by the right-hand spring jaws 12 and 13 so as to resist a tendency to pull the tip of the wire away from the stop 34, while the portion of the wire leading from the coil or reel is clutched by the left-hand jaws 12 and 13, thereby preventing additional wire from being fed to the loop. Then the object to be tied is inserted in the loop, where it is held clear of the mechanism by posts 36 and is placed with one side against the riser 47, as shown in Fig. 2, after which the loop is partly tightened by hand by pulling the coil end of the wire toward the left. Next, the coil end of the wire is slipped between the jaws 19 on the slide 18, so that the moving of this slide by the thrust rod 20 will cause the machine to effect a further tightening of the wire, since every rotation of the cam 25 actuates this thrust rod through the agency of the lever 21 and the spring 22. Since the jaws 19 operate in the same direction as the left-hand spring jaws 12 and 13, the wedgingly mounted jaws 19 may open on the returning movement of the slide 18, and as the jaws 12 and 13 will prevent the wire from slipping, the next movement of the slide toward the left will cause the jaws 19 to take a fresh grip on the wire. Consequently, the rapidly repeated pushes of the rod 20 will continue to tighten the wire loop around the package until the tension of the spring 22 is reached, after which

the slide 18 remains stationary and the further movement of the lever 21 only serves to alternately compress and relax the spring 22. As soon as this point is reached (that is to say, as soon as the wire binding has been tensioned to the degree for which the spring 22 is adjusted by the nuts 23), the trip lever 32 is moved out of its stop position of Fig. 4, thereby permitting the plunger 27 to engage the ratchet formation in the cam and hence causing the continually revolving cam to rotate the shaft 2 with it.

A light spring 42 connects the rod 20 to the table and returns this rod after each thrust, besides aiding the spring 22 to limit the tensioning of the wire.

As soon as the shaft begins to rotate from its initial position of Fig. 7, the gear 9 turns the floating pinion 8 (which pinion is kept clear of the package by the posts 36), thereby twisting the overlapped wire portions at each side of this pinion. Meanwhile, the manually operated trip lever 32 has been released and the spring 33 causes it to hold its tip ready to wedge between the cam and the strap 31 when the cam has almost completed one revolution, thereby unlatching the clutch and allowing the clutch body, together with the shaft upon which the latter is fast, to be stopped by the engagement of a pin 50 on the clutch body with a shoulder 41 on the lever 32. To insure a continuing of the rotation of the shaft to the point at which the slot in the pinion is exactly vertical, so as to permit an easy release of the wire from the machine, I preferably mount on the shaft a weighted arm 37 so positioned with respect to the strap 31 that it will tend to force the rotation of the shaft until the pin 50 positively engages the shoulder 41 on the lever 32. Before the shaft reaches this stopping position, the cutters 10 (which, as shown in Fig. 7, are mounted in advance of the initial position of the shaft) shear off both of the lower wires of the loop as shown in Fig. 5; that is to say, one cutter clips a short piece off the free end and the other severs the loop from the supply portion of the wire. However, since the cutters are mounted in advance of the initial position of the shaft, the intertwisting of the overlapped wire portions continues after this cutting, thus turning the wire ends in the finished loop toward the interior of the loop as shown in Fig. 6. During this completion of the twisting, one of the cutters 10 pushes a slide 39 out of the way, thereby releasing auxiliary latches 38 which prevent the wire portions from slipping prematurely out of the slot in the floating pinion, this slide being returned to its operative position by a lever 40. When the tie is thus finished, the package may be raised by means

of the lifting fork 6, which causes the frame 5 to strip the wires out of the pinion 8; or, the package may merely be slid along on the posts 36 in case another loop is to be placed over it.

It will be evident from the above that after the wire loop has been manually disposed as in Fig. 2, the machine automatically performs the cycle of operations comprising the tightening of the wire to a predetermined tension, the forming of the two twists, and the cutting off of the twist ends at the proper time during the twisting operation, the releasing of the auxiliary latches 38 which keep the wires from slipping out of the slot in the pinion, the turning of the extreme wire ends toward the interior of the loop, and the stopping of the operative mechanism when the tie is finished. Moreover, since the posts 36 keep the pinion 8 clear of the object which is being wrapped and since the latches 38 prevent portions of the wire adjacent to the twists from being drawn against the object, my appliance may be used even with objects having a delicate surface, such as paper-wrapped packages. So also, if the object wrapped is incompressible, the loop after being completed may be slipped off the object (in a form shown for example in Fig. 6), so that my appliance may also be used for forming wire loops suitable for use as hoops, hose-bands or the like. In accordance with the provisions of patent statutes, I have described the principle of operation of my invention, together with the apparatus which I now consider to represent the best embodiment thereof; but I desire to have it understood that the apparatus shown is only illustrative, and that the invention can be carried out by other means.

I claim as my invention:

1. A wire loop closing machine, including means for holding the loop with each of its intended terminals overlapping a wire portion spaced from the other terminal, means for intertwisting each intended terminal portion with the wire portion overlapped thereby, and means for cutting off one of the said terminal portions, the cutting means being so timed in operation with respect to the twisting means that the cut end will be directed substantially toward the interior of the finished loop.

2. A wire loop closing machine, including means for holding the loop with relatively overlapped ends, means for tightening the loop to a predetermined tension, and means for thereafter intertwisting each end portion of the loop with the part of the wire adjacent thereto without relaxing the tension on the loop.

3. A package tying machine, including means for holding a wire loop with relatively overlapped ends, means for main-

taining a package within said loop, and means for tightening the wire to a predetermined tension about the package subsequent to the formation of the loop.

5 4. A package tying machine, including means for holding a wire loop with relatively overlapped ends, means for maintaining a package within said loop, means for tightening the wire about the package
10 to a predetermined tension subsequent to the formation of the loop, and means for thereafter intertwisting two relatively spaced parts of the overlapped wire portions while the wire is under the said pre-
15 determined tension.

5. A package tying machine, including means for maintaining a wire loop around the package with two portions of the loop relatively overlapped, power-driven and
20 continuously reciprocating means for tensioning the wire around the package subsequent to the formation of the loop, and normally inoperative means for intertwisting a part of the relatively overlapped wire
25 portions operable subsequent to the tensioning of the loop.

6. A package tying machine, including means for maintaining a wire loop around the package with two portions of the loop
30 relatively overlapped, power-driven reciprocating means for tensioning the wire around the package, and means for adjusting the last named means to vary the said tensioning.

7. A package tying machine, including means for holding a wire loop with relatively overlapped ends, means for maintain-
35 ing a package within said loop, means for spacing the overlapped wire portions from the package, means engaging a part of the wire portions thus spaced from the package
40 and arranged for intertwisting a part of the said wire portions, and common means for actuating the last-named means and for severing the wire adjacent to the twist, the
45 severing means being arranged for operating approximately a half turn before the cessation of the twisting.

8. A package tying machine, including
50 means for holding a wire loop with relatively overlapped ends, means for maintaining a package within said loop, means for spacing the overlapped wire portions from the package, means engaging a part of the
55 wire portions thus spaced from the package for intertwisting said wire portions, means for severing the wire adjacent to the twist, and means for discontinuing the intertwisting at a predetermined point after the said
60 severing.

9. In a wire loop forming machine, wire tightening means including a reciprocable
65 slide, means carried by the slide for gripping the wire to move the same in one direction only, and means limited by a pre-

determined tension of the wire for reciprocating the slide.

10. In a wire loop forming machine, wire tightening means including a reciprocable
70 slide, means carried by the slide for gripping the wire to move the same in one direction only, a continuously reciprocated member, and connecting means interposed between said member and slide and including a spring arranged for rendering the
75 connecting means inoperative against the predetermined resistance to the movement of the slide.

11. A wire loop closing machine, including means for holding the wire loop with
80 relatively overlapped end portions, fixed and rotatable means engaging parts of said overlapped wire portions, means for revolving the rotatable means to intertwist certain of the overlapped wire portions, latching
85 means for holding certain wire portions in operative relation with respect to said fixed and rotatable means, and means for releasing the latching means substantially at the completion of the intertwisting. 90

12. A wire loop closing machine, including means for holding the wire loop with relatively overlapped end portions, fixed
95 and rotatable means engaging parts of said overlapped wire portions, means for revolving the rotatable means to intertwist certain of the overlapped wire portions, latching means for holding certain wire portions in operative relation with respect
100 to said fixed and rotatable means, and common means for severing the wire ends and releasing the latching means.

13. A wire loop closing machine, including means for holding the loop with each of
105 its intended terminals overlapping a wire portion spaced from the other terminal, means for intertwisting each intended terminal portion with the wire portion overlapped thereby, and cutting means separate from the said intertwisting means for cut-
110 ting off one of the terminal wire portions adjacent to the resulting twist.

14. A wire loop closing machine, including means for holding the loop with each
115 of its intended terminals overlapping a wire portion spaced from the other terminal, means for intertwisting each intended terminal portion with the wire portion overlapped thereby, and means separate from the said intertwisting means for cut-
120 ting off each terminal wire portion before the completion of the intertwisting.

15. A package tying machine, including means for holding a loop of wire previously
125 formed to the insertion of the package and with terminal portions of the loop relatively overlapped, means for tightening the loop to a tension sufficient to cause the wire to bear flatwise against all sides of the pack-
130 age except the one opposite the said over-

lapped wire portions, and means for there-
after uniting the said terminal portions.

16. A machine for wire-banding an angu-
larly sectioned package, including means for
5 disposing a loop of wire to receive the pack-
age and with portions of the loop relatively
overlapped adjacent to one side of the pack-
age, means for tightening the loop subse-
quent to the insertion of the package, to a
10 sufficient tension for causing the wire to in-
dent the edges of the package, and means for
intertwisting the overlapped wire portions
while maintaining the tension on the loop.

17. In a package banding machine, a sup-
15 port for a package, wire-twisting means car-
ried by the support, and means for holding
a loop of wire in operative relation to the
twisting means and disposed for inserting the
package therein.

18. In a package banding machine, a sup-
20 port for a package, and means carried by
the support for holding a loop of wire in po-
sition for inserting a package therein, the
loop-holding means being adapted to be re-
leased by a tightening of the loop about the
25 package.

19. In a package banding appliance,
means for spreading a loop to a bore greater
than the periphery of the package, and
30 means for tightening the loop about the
package, the said loop-spreading means be-
ing operatively released by the said tight-
ening of the loop.

20. In an appliance for banding a pack-
35 age with a wire loop, a support for the
package, and means carried by the support
for determining the plane of the wire loop
and holding the loop in such plane irrespec-
tive of the package.

21. In an appliance for banding a pack-
40 age with a wire loop, a support for the pack-
age, means carried by the support for de-
termining the plane of the wire loop, and
means for tightening the loop about the
45 package, the said plane-determining means
being so arranged as to be released by the
tightening of the loop.

22. In an appliance for banding a package
with a wire loop, a support for the package,
50 means carried by the support for deter-
mining the plane of the wire loop, and means
operating substantially in the said plane
for tensioning the loop about the package
and rendering a portion of said first means
55 inoperative.

23. In a package banding appliance, a
support for a package, wire-twisting means
carried by the support and including a rota-
table pinion having a radial slot adapted to
receive terminal portions of the proposed 60
loop in overlapping relation; and a pair of
grippers on opposite sides of the pinion and
substantially in alinement with the said slot,
for gripping portions of the wire loop to
prevent enlargement of the latter. 65

24. In a package banding machine, wire
twisting means, two wire gripping means
substantially in alinement with the wire
twisting means and respectively at opposite
70 sides of the latter; and means for retracting
the wire through the wire twisting means
and through one of the said gripping means.

25. In a package banding appliance, a
table arranged for supporting a package and
having an aperture adjacent to the package,
75 a wire twisting pinion rotatably mounted
on the table and projecting upwardly
through the said opening, and a gear dis-
posed below the table and meshing with the
pinion. 80

26. In a package banding machine, a sup-
port for a package, a rotatable wire-twisting
pinion having a radial slot and mounted on
the support for movement toward and from
the package, and means for stopping the 85
pinion in a position in which the slot is di-
rected toward the package.

27. In a package banding machine, a sup-
port across which the banding wire is fed,
90 means above the support for holding the
upper portion of a loop formed from the
wire, and means on the support for holding
the terminal portions of the formed loop
against enlargement of the loop but permit-
ting the wire to slip therethrough for tight- 95
ening the loop.

28. In a package banding machine, a sup-
port across which the banding wire is fed,
means above the support for holding the
upper portion of a loop formed from the 100
wire, and means for twisting the terminals
of the wire loop together.

29. A package banding machine compris-
ing continuously operating loop tightening
means including a slip joint operable to pre- 105
vent effective operation of said means upon
predetermined tightening of the loop.

Signed at Chicago, November 10th, 1916.

JOHN SHERMAN McCHESNEY.