

(19) **DANMARK**

(10) **DK/EP 2824057 T3**



(12)

Oversættelse af
europæisk patentskrift

Patent- og
Varemærkestyrelsen

-
- (51) Int.Cl.: **B 66 C 1/10 (2006.01)** **B 66 C 1/44 (2006.01)** **B 66 C 1/62 (2006.01)**
- (45) Oversættelsen bekendtgjort den: **2017-09-11**
- (80) Dato for Den Europæiske Patentmyndigheds bekendtgørelse om meddelelse af patentet: **2017-06-28**
- (86) Europæisk ansøgning nr.: **13176120.7**
- (86) Europæisk indleveringsdag: **2013-07-11**
- (87) Den europæiske ansøgnings publiceringsdag: **2015-01-14**
- (84) Designerede stater: **AL AT BE BG CH CY CZ DE DK EE ES FI FR GB GR HR HU IE IS IT LI LT LU LV MC MK MT NL NO PL PT RO RS SE SI SK SM TR**
- (73) Patenthaver: **Siemens Aktiengesellschaft, Werner-von-Siemens-Straße 1, 80333 München, Tyskland**
- (72) Opfinder: **Svinth, Kenneth Helligsoe, Bogensegade 3 4. tv, 8000 Århus C, Danmark**
Moeller, Jesper, Nørregårdsvej 78, 7330 Brande, Danmark
- (74) Fuldmægtig i Danmark: **Zacco Denmark A/S, Arne Jacobsens Allé 15, 2300 København S, Danmark**
- (54) Benævnelse: **Løft af et tårnsegment**
- (56) Fremdragne publikationer:
EP-B1- 2 402 278
WO-A1-2012/093940
DE-A1-102011 003 164
DE-A1-102011 011 603
US-A1- 2009 044 482

DESCRIPTION

[0001] The present invention concerns a raising device realized to be connected to a tower segment of a wind turbine. It also concerns a method of equipping a tower segment of a wind turbine for transport.

[0002] Wind turbines comprise a tower and a nacelle placed on top of that tower, whereby the nacelle is equipped with a rotor which rotates due to the impact of wind. In the nacelle, the rotational movement of the rotor is used to generate electric power.

[0003] Large wind turbine towers often comprise a number of tower segments, e. g. made of steel, which when assembled together form the complete wind turbine tower. The assembly of large wind turbine towers - in particular under offshore conditions, but also onshore - consumes a lot of time, effort, and financial resources. The standard state of the art is to assemble a wind turbine tower by attaching a number of brackets to an end flange of a tower segment and to connect a number of wires to these brackets. These wires are connected to a crane or to a similar raising machine and the tower segment is raised and transported to the site of assembly where it is connected either to a foundation of the wind turbine tower or to a lower tower segment to which the tower segment in question is then attached by e. g. bolting. After such assembly steps, the wires have to be disconnected from the tower segment, as well as the brackets, and the same procedure must be re-done for each tower segment until the complete wind turbine tower is established.

[0004] Such procedure is very time-consuming and complicated in that it implies an attachment of both brackets and wires to the tower flange first and a detachment of both after the assembly process of each tower segment. In particular it implies, that staff have to manually attach the brackets and wires and later detach them again. This also constitutes a certain potential danger for staff, in particular in the upper operating heights of the wind turbine tower which can have up to 150 metres of height or even higher. The enormous need of installation time also means a large consumption of resources as for instance under offshore conditions, an installation vessel is necessary to carry the crane. The use of such vessel is very costly and thus any reduction of usage time of such vessel implies an enormous saving. Similar effects can be seen on onshore sites, with a lower, but still substantial cost factor. Furthermore, the forces and tensions inflicted on the tower flange during raising and transport is enormous: potentially (depending on wind conditions), at each bracket connection to the wires the full load of the complete tower section can occur so that the flanges must be designed very stable and large.

[0005] EP 2 402 278 B1 describes an arrangement for raising a tower segment of a wind turbine. It comprises a beam and a cross beam along both of which holding members are attached which holding members can engage with a flange of a tower segment when moved along the beam and cross-beam. The holding members are moved manually or by a motor into a desired operating position at which they can engage with a counter-shape of the tower

segment.

[0006] It is the object of the present invention to provide an alternative raising device (and raising method), in particular an improved one in comparison with the above-mentioned state of the art. Preferably such improvement is realized by providing a raising device the use of which is less time-consuming than that of the state of the art.

[0007] This object is met by the raising device according to claim 1 and by the method according to claim 15.

[0008] According to the invention, a raising device of the kind mentioned in the introductory paragraph comprises a connection member to a raising machine and a plurality of holding members positioned at predefined distances from each other and orientated to be movable in radial locking directions which locking directions are such that the holding members when moved into a locking position at a predefined engagement position of the tower segment engage with a counter-shape of the tower segment, whereby the holding members are automatically tiltable and/or shiftable into the locking position by a movement mechanism, whereby the holding members are mechanically interconnected via the movement mechanism with the connection member via a number of hinges such that upon pulling the connection member upwards, the holding members automatically tilt and/or shift into the locking position unless blocked. In this context it may be noted that the connection of the raising device to the tower segment is preferably carried out at the top of such tower segment. Thus, if one considers the tower segment to be essentially tubular or cylindrical in shape, the top of such tower segment is that essentially round opening of the tower segment which is to face upwards when assembled in an upright position on the assembly site. This also implies that the tower segment can be raised by means of the raising device in such upright position, i.e. in the same orientation in which it is to be assembled eventually at the assembly site.

[0009] A connection member may for instance comprise a hook or an eye which can engage with a corresponding eye or hook from the raising machine. The raising machine may for instance be a crane with a wire to which the connection member can be connected.

[0010] It may further be noted that the expression "tower segment" refers both to a segment of a wind turbine tower which - together with other such segments - is part of the complete wind turbine tower but also may refer to a complete wind turbine tower. In fact, it is preferred that a complete tower be raised in one piece (i.e. in an already assembled state in which segments of the tower have been connected to form the complete tower) in the context of the invention. Firstly, the raising device according to the invention makes such raising possible because it can be built stable enough to carry the complete weight of such complete tower at one time. This would not be the case with the above-mentioned raising method with brackets and wires: several brackets would be necessary to achieve an overall enough stability of the connection of the tower segment to the raising device during transport. That also implies that several wires would be necessary and that each one of these wires would have to be made stable enough to carry the entire weight of the wind turbine tower due to movements of the

tower in the wind. Thus, only the sufficiently stable device according to the invention provides for a solution in which an entire wind turbine tower can be raised as one piece. In fact, even under conditions of transport of the wind turbine tower in one piece, with the raising device according to the invention it is possible to reduce the size and weight of the upper flanges if they are to be used as the counter-shape.

[0011] Secondly, such transport in one piece has the advantage that assembly times at the assembly site can be reduced to an absolute minimum. The entire wind turbine tower can already be transported to the assembly site in one piece and then simply be raised and transported from a means of transport such as a vessel to the assembly site where it is to be installed. Assembly time on that assembly site is thus dedicated wholly to the processes of raising, transport and installation of the wind turbine tower on a foundation.

[0012] The raising device comprises a plurality of holding members positioned at predefined distances from each other. These predefined distances and thus corresponding predefined positions of the holding members correspond with the position of the counter-shape of the tower segment to which the raising device is to be connected. That implies that, unlike in the state of the art mentioned above, the holding members are not positioned anywhere and can then be brought into a desired operating position manually or by means of a motor. Instead, the holding members are generally situated in that desired operating position and need not be moved there. In this context, an "operating position" means such position in which the holding member can be connected to (or disconnected from) the counter-shape of the tower segment by a pre-defined movement, namely a movement from an open position into a locking position and reverse. Thereby, the open position and the locking position of the holding member are also clearly defined and each holding member is mechanically limited in its movement so that it can only move between those two positions (i.e. between the open position and the locking position).

[0013] Corresponding to the open position and the locking position of each of the holding members is its locking direction and - reverse - its unlocking direction (i.e. the counter direction of the locking direction). Both the locking direction and unlocking direction are radial, i.e. along a straight line from the centre point of the (essentially tubular) tower segment to the shell of the tower segment in a section of the tower segment perpendicular to its longitudinal tubular extension. That means that the locking direction is either towards that centre point or away from it and that the unlocking direction is exactly opposite. For instance, the raising device may comprise three holding members aligned at equal distances along an outer or inner circumference of a tower segment to which they are to be connected. For that purpose each of the holding members can be connected at a predefined position to a holding beam at essentially one end of the holding beam whereas the other end of the holding beam is connected to the corresponding ends of the other holding beams. Therefrom results a kind of star-like structure of three holding beams.

[0014] Furthermore, the holding members are automatically tiltable and/or shiftable into their locking position by means of a movement mechanism. That implies that upon activating the

movement mechanism the holding members are automatically tilted and/or shifted from the open position into the locking position or vice versa. Automatically tilting or shifting preferably implies a purely mechanical movement rather than one induced by manual effort and/or motor power transmission and/or hydraulic / pneumatic power transmission. However, a support by a motor or a hydraulic system is principally feasible. It is particularly preferred that the movement mechanism connects the holding members to the connection member of the raising device so that a particular movement of the connection member automatically produces the tilting and/or shifting movement of the holding members unless such movement is intentionally blocked.

[0015] In the context of the invention, the term "holding member" refers to such a mechanical holding device that is movable in and/or against the locking direction. In addition, the raising device may also comprise other, non-movable members with a holding function and design which may for instance be used as a counterpart of a holding member. For instance, one such non-movable member may engage with the counter-shape of the tower segment at a first position, for instance by transferring the non-movable member below the counter-shape by means of form fit, i.e. by positioning the complete raising device with respect to the tower segment such that the non-movable member is engaged with the counter-shape. Then, in order to make sure that the raising device is stably connected to the tower segment, the holding members are moved into their locking positions at a second position (which functions as a counter position to the first position) so that the holding members in their locking positions together with the non-movable members provide a firm hold of the tower segment.

[0016] The invention also concerns a tower segment of a wind turbine equipped with a raising device according to the invention.

[0017] According to the invention, a method of the above-mentioned kind comprises the steps of

- connecting a raising device with a connection member to a raising machine to the tower segment, the raising device comprising the connection member and a plurality of holding members positioned at predefined distances from each other and orientated to be movable in radial locking directions which locking directions are such that the holding members when moved into a locking position at a predefined engagement position of the tower segment engage with a counter-shape of the tower segment, whereby the holding members are automatically tiltable and/or shiftable into the locking position by a movement mechanism, whereby the holding members are mechanically interconnected via the movement mechanism with the connection member via a number of hinges such that upon pulling the connection member upwards, the holding members automatically tilt and/or shift into the locking position unless blocked.
- tilting and/or shifting the holding members into the locking position at the predefined engagement position of the tower segment engaging with the counter-shape.

[0018] Optionally, this method further comprises a raising step in which the raising device is

raised by means of the raising machine. This step takes the equipment method further so that the method then constitutes a raising method or a method of transport rather than just a method of equipping the tower segment.

[0019] Particularly advantageous embodiments and features of the invention are given by the dependent claims, as revealed in the following description. Features of different claim categories may be combined as appropriate to give further embodiments not described herein.

[0020] Preferably, at least one holding member, most preferred each holding member, comprises a claw (which can also be considered to be a gripper). Such claw can engage with the counter-shape of the tower segment, for instance by going partially underneath and/or around the counter-shape. For instance, which is preferred, the counter-shape of the tower segment comprises an inner or outer connection flange to another tower segment and/or towards the nacelle parts of the wind turbine. A claw can thus be tilted or shifted underneath the connection flange and hold it with ease.

[0021] As has been outlined before, the raising device may comprise three holding members. However, it is principally possible that it only comprises two holding members. It has been found particularly advantageous that the number of holding members is an even number and that the holding members are arranged in pairs of corresponding holding members. In this context, it is preferred that at least two corresponding holding members are aligned along a straight line. This line is preferably a radial line. In particular, these corresponding holding members can be realized and positioned and aligned such that their locking directions are counter directions. For instance, if the locking direction of a first holding member is towards the centre point of the tower section and the second, corresponding, holding member is positioned at the opposite side of the centre point of the tower section (with respect to the first holding member) and its locking direction is also towards the centre point of the tower section. Therefore, the second holding member's locking direction is the counter direction of the first holding member's locking direction. The tower segment is then held in between the two corresponding holding members which exert a holding force towards the inner side of the tower segment. In contrast, both corresponding holding members can also be orientated in the opposite locking directions, i.e. facing away from the centre point of the tower segment, in which case they exert a holding force towards the outside of the tower segment. The first such described embodiment is particularly useful if an outside flange is used as the counter-shape of the tower segment, whereas the second such described embodiment is particularly useful if an inside flange is used as the counter-shape of the tower segment.

[0022] In an embodiment with two corresponding holding members, it is particularly preferred that these are connected to one common holding beam. The (preferably straight) beam thus serves as a holding structure for the two corresponding holding members and constitutes the straight line along which the holding members are both aligned.

[0023] As for smaller and/or lighter tower segments, it has been found by the inventors that the use of two holding members can be sufficient, but three holding members already increase

the stability of the connection between the tower section and the raising device considerably. In particular, it has proven most advantageous to use four holding members because this provides for a very high stability whereas more than four holding members do not substantially add stability. In the context of four holding members, the use of corresponding (pairs of) holding members as outlined above is very advantageous: It is thus preferred that the raising device according to the invention comprises (at least) two pairs of corresponding holding members.

[0024] In this context, a preferred embodiment of the raising device according to the invention is characterized by a first pair of corresponding holding members being connected to a first common holding beam and a second pair of corresponding holding members being connected to a second common holding beam. This second holding beam is preferably realized as a cross-beam of the first holding beam, whereby it is particularly preferred that the cross-beam is orientated essentially perpendicularly to the first holding beam, which makes the construction of the raising device particularly stable. This further makes possible that the raising device can be positioned such that the point where the first holding beam and the second holding beam are interconnected can essentially be positioned at the above-mentioned centre point of the tower section and that from this centre point the holding members can be arranged essentially equidistantly along the (inner or outer) circumference of the tower section.

[0025] This embodiment can be further enhanced by interconnecting the first holding beam and the second holding beam by a number of diagonal connections such as interconnecting beams, ropes or the like. Such diagonal (inter)connections can further stabilize the raising device so that it can carry even larger loads without the danger of getting twisted or worn.

[0026] It is possible to only temporarily position the holding members at their predefined positions, i.e. at their predefined distances from each other. That means that the predefined distance can be varied depending on the kind (and width, i.e. in the case of a round tower segment its diameter and radius) of the tower segment to be raised. It is preferred that the holding members are fixedly installed, i.e. permanently fixed at the predefined distance. This is in particular so if complete towers are to be raised as one by the raising device because then the same width of the tower (segment) always applies for wind turbines of the same make of wind turbine: such tower must always carry a nacelle of a particular size, which depends on the nominal power output of the wind turbine. That width currently varies between about 3000mm and 4500mm. More specifically, currently a 3,6 MW wind turbine of the applicant has a width of 3128mm and a 6 MW wind turbine a width of 4145mm. A change of position of the holding members is not necessary in case one decides to always raise towers of the same make of wind turbines so that instead a more stable, namely fixed, position of the holding members is possible and highly preferred.

[0027] In this context it may be noted that also the orientation of the holding members, i.e. their designated locking direction could be changed (for instance to be able to engage both with inner and outer flanges of tower segments), but again, in particular in the above-mentioned context of complete towers to be raised, it is preferred that the holding members

are fixed also with respect to their orientation.

[0028] According to the invention the holding members are mechanically interconnected via the movement mechanism with the connection member via a number of hinges such that upon pulling the connection member upwards, the holding members automatically tilt and/or shift into the locking position unless blocked. This means that there is a mechanical tilting connection between the connection member and the holding members: Once the raising device has been brought into a particular position - designated for initiating the engagement of the holding members with their counter-shape(s) - the raising device only has to be pulled upwards via the connection member and automatically the holding members get into their locking positions. This highly automatized mechanism provides for a safe and very easy locking procedure which thus saves time, effort and expenditure.

[0029] As outlined before, it is advantageous if the holding members are realized, i.e. sized, mechanically designed and located, to engage with an upper (inner and/or outer) flange of the tower segment along its (inner and/or outer) circumference. This upper flange thus comprises (preferably constitutes) the counter-shape for the holding members. Such flanges have proven to be stable enough to withstand all raising forces, which means they can clearly carry the complete weight even of a complete tower. Such also applies for towers of today's sizes and weights, e.g. for 90 metre high steel towers weighing about 300 tons.

[0030] For safety reasons it is preferred that the raising device according to the invention further comprises a blocking mechanism realized to block a movement of the holding members into and/or out of the locking position. That means that once the blocking mechanism is activated, the holding members will essentially remain in their open or locked position. If the holding members are thus in their locking position they cannot be unlocked until the blocking mechanism is deactivated. This prevents the raising device from sudden failure of the locking function of the holding members, for instance due to weather conditions or other negative impacts on the tower segment in a raised position. Thus, the blocking mechanism is a means of how to effectively prevent the tower segment from uncontrolledly falling down while being raised by means of the raising device.

[0031] In particular, such blocking mechanism can comprise a pin which engages with a recess of a movable element of the raising device (i.e. in particular of the movement mechanism) which movable element is connected to at least one of, preferably all of the holding members in order to block a movement of that / the holding member(s). The pin can easily be inserted manually into the recess once the holding member(s) has / have reached a desired position. The same way, the pin can be extracted from the recess once a different position (and thus a change of position) of the holding member(s) is desired.

[0032] The invention can further be enhanced by the raising device also comprising a cover realized to cover an open part of the tower segment, i.e. an upper opening of the tower segment facing upwards when the tower segment is positioned in the designated position of assembly in which a nacelle can be placed on the top of the tower. Such cover can serve to

shield the inside of the tower segment from influences from above, in particular rain or snow. The cover can be loosely connected to the raising device, for instance when the cover is installed on the tower segment. In such case, the cover can be installed on the tower segment first and then the raising device can be connected to both the tower segment and the cover. Alternatively, the cover and the raising device can be assembled (i.e. interconnected) and then connected to the tower segment together.

[0033] In this context, it is particularly preferred that the cover comprises at least one opening realized as a service opening for staff and/or as a through-hole for at least one of the holding members. A service opening, for instance a hatch which can be closed by a cover when no staff wants to pass can permit staff from the inner side of the tower segment to the outside on top of the tower segment (or reverse), for instance in order to permit assembly work in these locations. A through-hole is preferably sized such that it permits the passage of the corresponding holding member. It may be sized and realized such that it is essentially in contact with the holding member (or a connection of the holding member to other parts of the raising device) so that essentially no rain or snow can pass through the through-hole. It may also be sized slightly larger to permit easier passage of the holding member (or a connection of the holding member to other parts of the raising device).

[0034] Other objects and features of the present invention will become apparent from the following detailed descriptions considered in conjunction with the accompanying drawings. It is to be understood, however, that the drawings are designed solely for the purposes of illustration and not as a definition of the limits of the invention. They are not necessarily drawn to scale.

Fig. 1 shows a perspective view of a raising device according to an embodiment of the invention,

Fig. 2 shows a first side view of the same raising device placed on top of a tower segment in a locked position,

Fig. 3 shows a second side of the same raising device without the tower segment,

Fig. 4 shows a detailed view of a detail from Fig. 2,

Fig. 5 shows perspective sectional view of a further detail of the same raising device,

Fig. 6 shows a top view of the same raising device equipped with a cover,

Fig. 7 shows a perspective view of the same raising device with the cover placed on top of a tower section,

Fig. 8 shows a block diagram depicting principal steps of an embodiment of the method according to the invention.

[0035] Fig. 1 shows a raising device 1 for raising a tower section (not shown) of a wind turbine. The raising device 1 comprises a connection member 3 realized as an eye 3 which is attached via a first hinge 5 to four connection shapes 28. To these connection shapes 28 there is each hingedly attached via a second hinge 9 a connection beam 27. The connection beams 27 are thus connected essentially at their first end via the second hinges 9 to the connection shapes 28 and at their second ends to third hinges 11 to holding members 19a, 19b, 19c, 19d (the two latter being obscured in the figure due to the perspective view) realized as claws 19a, 19b, 19c, 19d. The holding members 19a, 19b, 19c, 19d are realized as two pairs of corresponding holding members 19a, 19b, 19c, 19d, namely a first pair of corresponding holding members 19c, 19d is aligned along a first holding beam 21a and a second pair of corresponding holding members 19a, 19b is aligned along a second holding beam 21b.

[0036] The raising device 1 thus further comprises a first holding beam 21a and a second holding beam 21b which is a perpendicularly positioned cross-beam to the first holding beam 21a. These two holding beams 21a, 21b are directly interconnected at the centre C of the raising device 1 and indirectly by diagonal connections 23 at about the middle of the distance of each holding beam 21a, 21b from the centre C of the raising device 1 to the end of the respective holding beam 21a, 21b. At these ends of the holding beams 21a, 21b fourth hinges 13 are positioned which connect each of the holding beams with one of the claws 19a, 19b, 19c, 19d.

[0037] From the centre C of the raising device 1 at which the two holding beams 21a, 21b are interconnected directly, an upward-facing beam 30 is also connected to the two holding beams 21a, 21b (directly or indirectly). That beam 30 is hollow and essentially extends up to the connection shapes 28, but is not directly connected to these. Inside the hollow beam 30 there is positioned another guiding beam 7 which is connected to the connection shapes 28 and thus indirectly to the connection member 3.

[0038] At either end of each of the holding beams 21a, 21b there are positioned legs 15 extending downwards (i.e. away from the connection member 3) on which the raising device 1 can rest stably if stored on ground. In addition, at all of these mentioned ends of the holding beams 21a, 21b there is also an eye 17. The eyes 17 can be used to move and steer the raising device (and a tower segment connected to it) in a circle, i.e. to orientate the tower segment during a raising and transport processes and in particular during assembly of the tower segment at a designated operating site. Further, the raising device 1 comprises a blocking mechanism 25 the function and details of which will be explained with reference to Figs. 4 and 5.

[0039] When the raising device 1 is raised by a raising machine such as a crane, it is connected to that raising machine via the connection member 3 which is thus raised in an upward direction U. Reversely, when the raising device 1 is lowered to the ground, it is lowered in a downward direction D until the connection member 3 goes downwards into the position shown in Fig. 1. At the same time, due to the movement mechanism of the raising device 1, the raising force while raising the raising device 1 in the upward direction is transferred via the

four hinges 5, 9, 11, 13 into a moving force which tilts each of the holding members 19a, 19b, 19c, 19d in a locking direction L, i.e. out of the open position depicted in Fig. 1 into a locking position. Reversely, when no raising force is applied to the raising device 1 any more, i.e. when the connection to the raising machine via the connection member 3 is released or lose, the weight of the upper parts of the raising device 1 is enough to move the holding members 19a, 19b, 19c, 19d from the locking position in an counter direction A to the locking direction L into the open position again. Additionally, this movement in the counter direction A may be supported by actors such as springs (not shown).

[0040] In essence, this construction permits an automatic tilting movement of the holding members 19a, 19b, 19c, 19d in both the locking direction L and the counter direction A based on the force exerted on the connection member 3. No manual or motor support of that movement is necessary.

[0041] In this context, it can be stated that the term "movement mechanism" refers to all those movable parts of the raising device 1 which interconnect the connection member 3 with the holding members 19a, 19b, 19c, 19d serving to transfer the raising (and lowering) forces inflicted on the connection member 3 into forces for moving the holding members 19a, 19b, 19c, 19d into or out of the locking position, i.e. in the locking direction L or the counter direction A.

[0042] Referring now to Fig. 2, which is a first side view of the same raising device 1 installed on top of a tower segment 31 of a wind turbine 100. The raising device 1 is thereby in a locked position, i.e. the holding members 19a, 19b, 19c, 19d have been moved completely in the locking direction L. Therefore they engage with an inwards protruding part (not shown) of an inner flange 29 of the tower segment 31 which inner flange 29 is comprised of the top element of the tower segment 31 which can be seen in Fig. 2 and of the inwards protruding part which cannot be seen. As the holding members 19a, 19b, 19c, 19d are all orientated with their locking directions towards the inner surface of the tower segment 31, their lower part has been tilted below the inner flange 29 so that the holding members 19a, 19b, 19c, 19d facing into four directions and all orientated in a 90° angle to the next holding member hold the inwards protruding part of the inner flange 29 firmly from underneath. In this arrangement, the feet 15 are positioned outside of the tower segment 31.

[0043] Fig. 3 shows the same raising device 1 in a second side view which is perpendicular to the side view of Fig. 2. It can be seen here that along the first holding beam 21a (and the same applies with respect to the second holding beam 21b and all the elements connected with it) the holding members 19a, 19b, 19c, 19d are positioned fixedly via their fourth hinges 13 to the first holding beam 21a along a predefined distance d. The locking direction L₁ of the holding member 19d at the right hand side is orientated away from the centre C of the raising device 1 further to the right whereas the locking direction L₂ of the holding member 19c at the left hand side faces exactly in the opposite direction.

[0044] Further, it can be seen in Fig. 3 that to each of the holding members 19a, 19b, 19c,

19d there is connected a connection eye 33 projecting towards the centre C of the raising device 1. These connection eyes 33 can be used to connect to a cover which will be explained with reference to Figs. 6 and 7.

[0045] Figs. 4 and 5 serve to explain the blocking mechanism 25 in more detail. The blocking mechanism 25 comprises an inlet shell 35 for a pin 37 through which the pin 37 can be led inside the beam 30 (obscured in this figure due to the perspective). A handle 39 is connected to the pin 37 in order to facilitate manual (or motor-driven) movement of the pin 37 into the beam 30 and out again. At the lower end of the handle 39 two catch bolts 41a, 41b are positioned which are realized to firmly hold the handle 39 in a desired first, open, position (corresponding to the left catch bolt 41a) and in a desired second, blocked, position (corresponding to the right catch bolt 41b). Thus, the catch bolts 41a, 41b serve to fix the handle 39 in one of these two positions to prevent it from moving undesiredly.

[0046] Fig. 5 shows a section view of the beam 30 with its inner guiding beam 7. In order for the pin 37 to block the movement of the movement mechanism, the guiding beam 7 comprises two recesses 26 along its longitudinal extension (i.e. the upward direction U and the downward direction D) one of which is depicted in Fig. 5. At two given predefined positions of the guiding beam 7 corresponding with the locking position and the open position of the holding members 19a, 19b, 19c, 19d the pin 37 can thus be inserted into the recesses 26 of the guiding beam 7 thus blocking the guiding beam 7 in its position and further blocking any movement of the movement mechanism.

[0047] Turning to Figs. 6 and 7, this shows the same raising device 1 which is further equipped with a cover 43. The cover 43 is connected to the raising device via 1 the connection eyes 33 (cf. Fig. 3) and serves to shield the inner side of the tower segment 31 from the ambient environment, in particular from rain or snow. The cover 43 comprises a first opening 47 realized as a service hatch 47 through which staff can climb in order to get from the inside of the tower segment 31 to the upper side of the cover 43 or reverse. Moreover, the cover 43 comprises four through-openings 45 through which the holding members 19a, 19b, 19c, 19d are inserted.

[0048] Fig. 8 shows a schematic block diagram of an embodiment of an equipment method Z according to the invention. Thereby, reference is made to the embodiment of the raising device explained in the previous figures. The method comprises the following steps in the given sequence of actions:

In a first step Y the raising device 1 connected with its connection member 3 to a raising machine is connected to the tower segment 31. Alternatively, the raising device 1 may first be connected to the tower segment 31 and then via the connection member 3 to a raising machine. In a second step X the holding members 19a, 19b, 19c, 19d are tilted into the locking position at the predefined engagement position of the tower segment 31 engaging with the counter-shape, i.e. the inner flange of the tower segment 31. In an optional step W the raising device 1 is raised by means of the raising machine by which action the tower segment 31 is

automatically raised together with the raising device 1 and can thus be transported, for instance to an assembly site of the wind turbine.

[0049] Although the present invention has been disclosed in the form of preferred embodiments and variations thereon, it will be understood that numerous additional modifications and variations could be made thereto without departing from the scope of the invention.

[0050] For the sake of clarity, it is to be understood that the use of 'a' or 'an' throughout this application does not exclude a plurality, and 'comprising' does not exclude other steps or elements.

REFERENCES CITED IN THE DESCRIPTION

This list of references cited by the applicant is for the reader's convenience only. It does not form part of the European patent document. Even though great care has been taken in compiling the references, errors or omissions cannot be excluded and the EPO disclaims all liability in this regard.

Patent documents cited in the description

- EP2402278B1 [0005]

Patentkrav

- 5 1. Løfteindretning (1), der er indrettet til at forbindes med et tårnsegment (31) af en vindmølle (100) og omfatter et forbindelseselement (3) til en løftemas-
- 10 5 skine og en flerhed af holdelementer (19a, 19b, 19c, 19d), der er anbragt med foruddefineret indbyrdes afstand (d) og orienterede til at kunne bevæ-
- 15 10 ges i radiale låsningsretninger (L , L_1 , L_2) hvor låsningsretningerne (L , L_1 , L_2) er udformet, således at holdelementerne (19a, 19b, 19c, 19d), når de bevæ-
- 20 15 ges ind i en låsningsposition ved en foruddefineret indgrebsposition af tårnsegmentet (31), går i indgreb med kontraform af tårnsegmentet (31), **kendetegnet ved, at** holdelementerne (19a, 19b, 19c, 19d) kan vippes og/eller forskydes automatisk ind i låsningspositionen ved hjælp af en bevægelsesmekanisme, hvor holdelementerne (19a, 19b, 19c, 19d) er mekanisk forbundet via bevægelsesmekanismen med forbindelseselementet (3) via et
- 25 20 antal hængsler (5, 9, 11, 13), således at efter forbindelseselementet (3) trækkes opad, vil holdelementerne (19a, 19b, 19c, 19d) automatisk vippe og/eller forskydes ind i låsningspositionen, medmindre de er blokerede.
- 30 2. Løfteindretning ifølge krav 1, hvor hvert holdelement (19a, 19b, 19c, 19d) omfatter en klo (19a, 19b, 19c, 19d).
3. Løfteindretning ifølge krav 1 eller 2, hvor mindst to tilsvarende holdelementer (19a, 19b, 19c, 19d) er på linje langs en lige linje.
- 25 4. Løfteindretning ifølge krav 3, hvor tilsvarende holdelementer (19a, 19b, 19c, 19d) er forbundet til én fælles bærebom (21a, 21b).
- 30 5. Løfteindretning ifølge krav 4, hvor et første par af tilsvarende holdelementerne (19a, 19b) er forbundet til en første fælles bærebom (21a), og et andet par af tilsvarende holdelementer (19c, 19d) er forbundet til en anden fælles bærebom (21b), der er udført som en tværbom (21b) af den første bærebom

(21a).

5 **6.** Løfteindretning ifølge krav 5, hvor den første bærebom (21a) og den anden bærebom (21b) er indbyrdes forbundet ved hjælp af et antal diagonale forbindelser (23).

10 **7.** Løfteindretning ifølge et hvilket som helst af de foregående krav, hvor holdelementerne (19a, 19b, 19c, 19d) er fast installeret i den foruddefinerede afstand (d).

15 **8.** Løfteindretning ifølge et hvilket som helst af de foregående krav, hvor holdelementerne (19a, 19b, 19c, 19d) er indrettede til at gå i indgreb med en øvre flange (29) af tårnsegmentet (31) langs dennes omkreds, hvor den øvre flange (29) omfatter kontraformen.

20 **9.** Løfteindretning ifølge et hvilket som helst af de foregående krav, omfattende en blokeringsmekanisme (25), der er indrettet til at blokere en bevægelse af holdelementerne (19a, 19b, 19c, 19d) ind i eller/og ud af låsningspositionen.

25 **10.** Løfteindretning ifølge krav 9, hvor blokeringsmekanismen (25) omfatter en stift (37), som går i indgreb med en udsparring (26) af et bevægeligt element (7) af løfteindretningen, hvor det bevægelige element (26) er forbundet med mindst ét af holdelementerne (19a, 19b, 19c, 19d) for at blokere en bevægelse af dette holdelement (19a, 19b, 19c, 19d).

30 **11.** Løfteindretning ifølge et hvilket som helst af de foregående krav, yderligere omfattende et låg (35), der er udført til at dække en åben del af tårnsegmentet (31).

12. Løfteindretning ifølge krav 11, hvor låget omfatter mindst én åbning (37, 39), der er udført som en vedligeholdelsesåbning (39) til personalet og/eller

som et gennemgående hul (37) til mindst ét af holdelementerne (19a, 19b, 19c, 19d).

5 **13.** Tårnsegment (31) af en vindmølle (100), som er udstyret med en løfteindretning (1) ifølge et hvilket som helst af de foregående krav.

14. Fremgangsmåde (Z) til at udstyre et tårnsegment (31) af en vindmølle (100) til transport, omfattende de følgende trin

10 - forbinde (Y) en løfteindretning (1) med et forbindelseselement (3) til en løftemaskine til tårnsegmentet (31), hvor løfteindretningen (1) omfatter forbindelseselementet og en flerhed af holdelementer (19a, 19b, 19c, 19d), der er anbragt med foruddefineret indbyrdes afstand (d) og orienterede til at kunne bevæges i radiale låsningsretninger (L, L₁, L₂), hvor låsningsretningerne (L, L₁, L₂) er udformet, således at holdelementerne (19a, 19b, 19c, 19d), når de

15 bevæges ind i en låsningsposition ved en foruddefineret indgrebsposition af tårnsegmentet (31), går i indgreb med en kontraform af tårnsegmentet (31), hvor holdelementerne (19a, 19b, 19c, 19d) kan vippes og/eller forskydes automatisk ind i låsningspositionen ved hjælp af en bevægelsesmekanisme, hvor holdelementerne (19a, 19b, 19c, 19d) er mekanisk forbundet via bevægelsesmekanismen med forbindelseselementet (3) via et antal hængsler

20 (5, 9, 11, 13), således at efter forbindelseselementet (3) trækkes opad, vil holdelementerne (19a, 19b, 19c, 19d) automatisk vippe og/eller forskydes ind i låsningspositionen, medmindre de er blokerede,

- vippe og/eller forskyde (X) holdelementerne (19a, 19b, 19c, 19d) ind i låsningspositionen ved den foruddefinerede indgrebsposition af tårnsegmentet

25 (31) under indgreb med kontraformen,

- eventuelt løfte (W) løfteindretningen (1) ved hjælp af løftemaskinen.

FIG 3

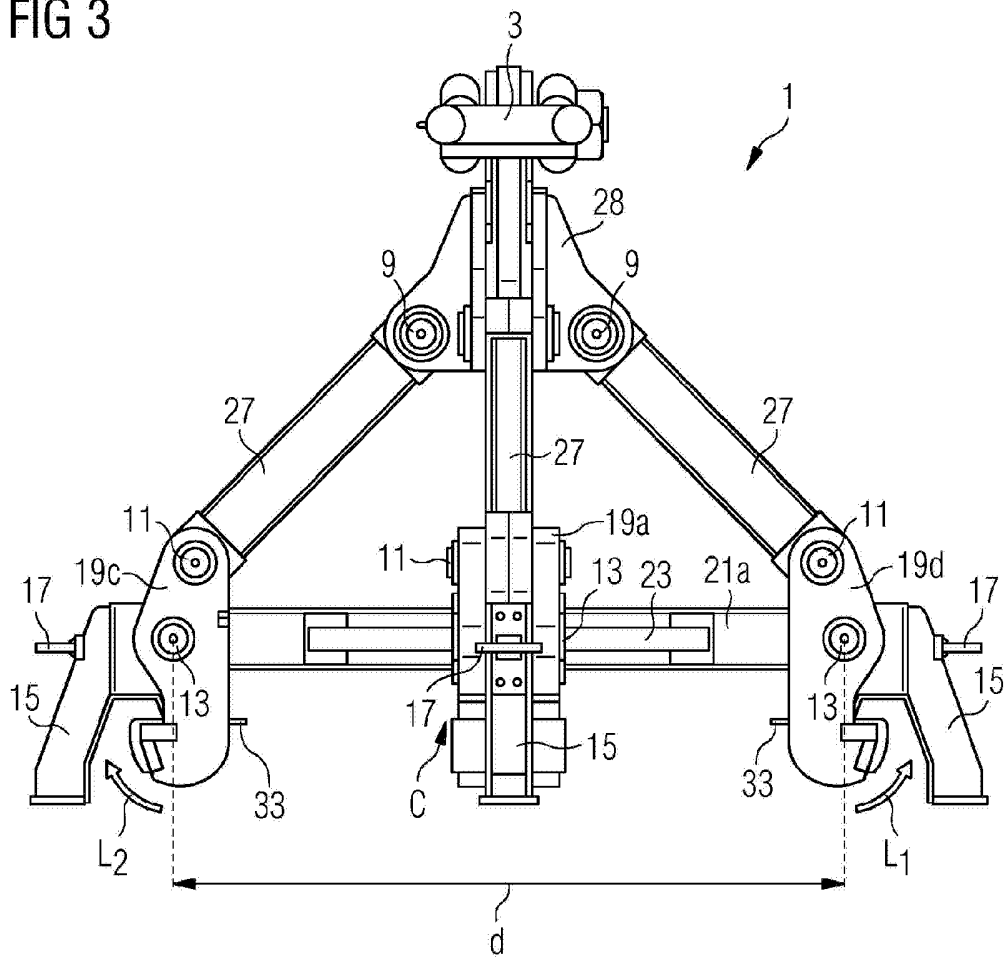

FIG 4

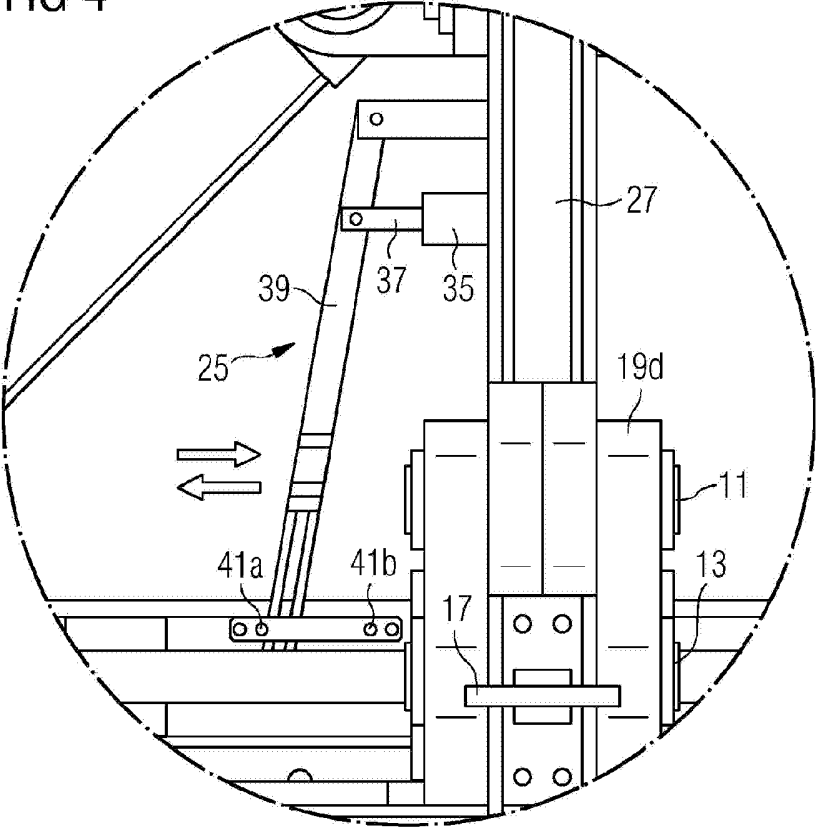

FIG 5

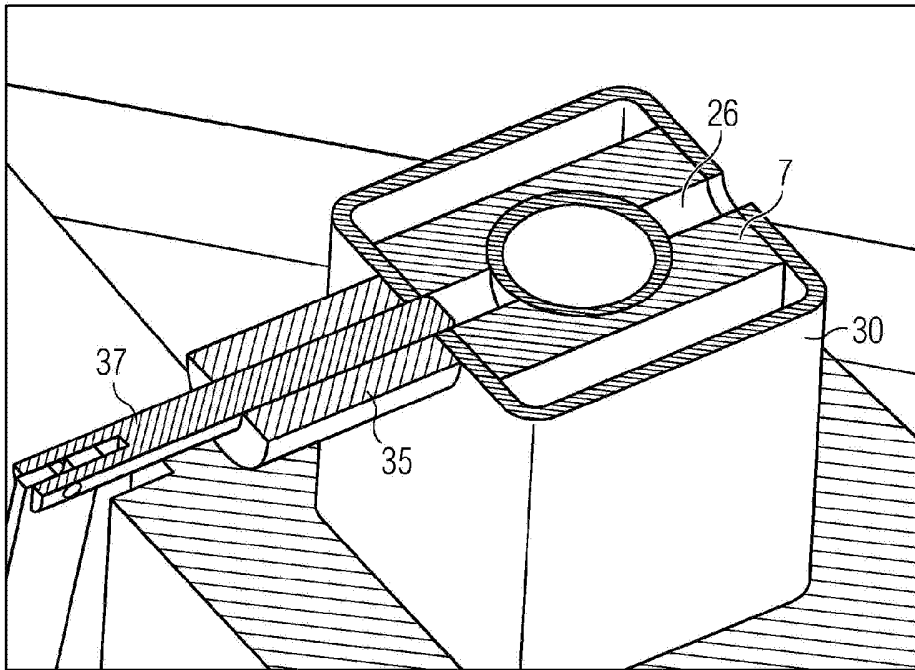

FIG 6

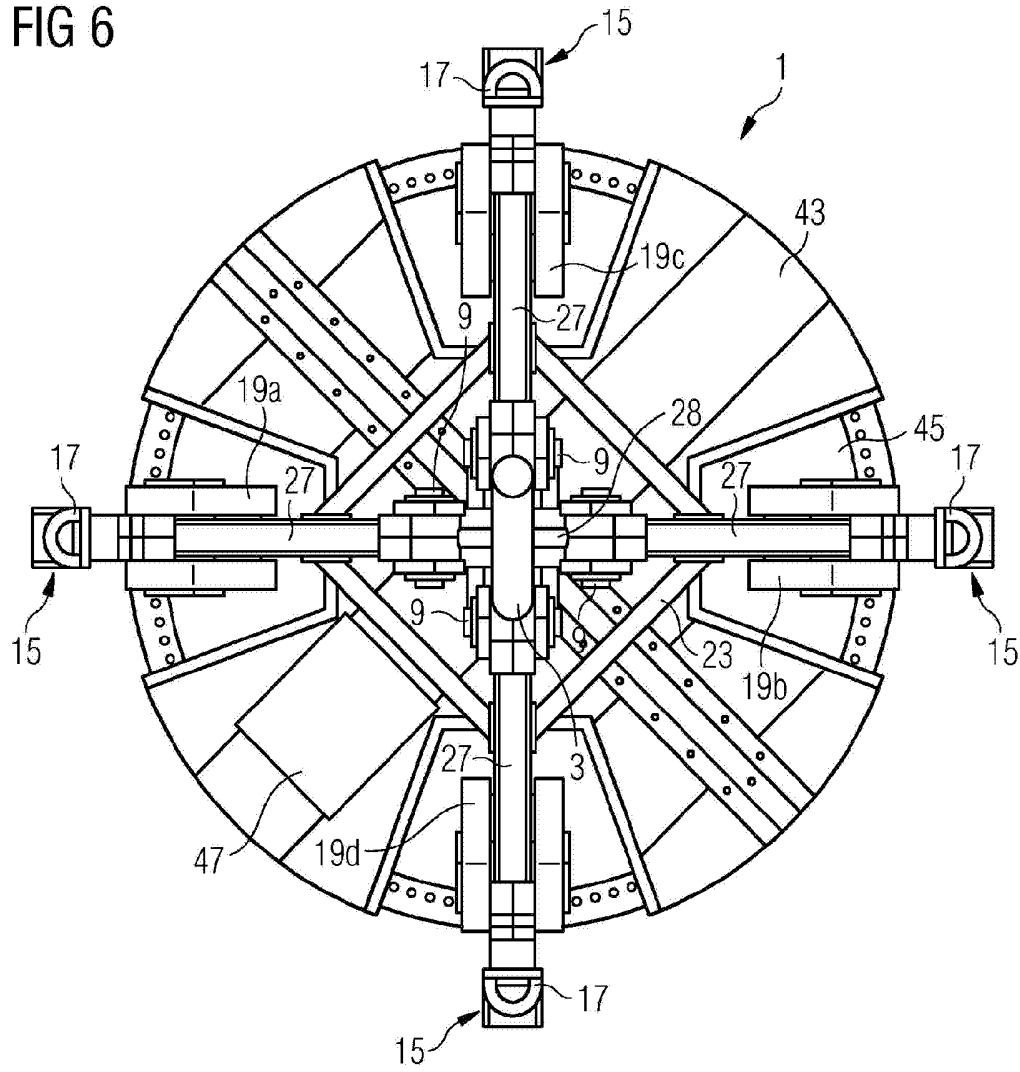

FIG 7

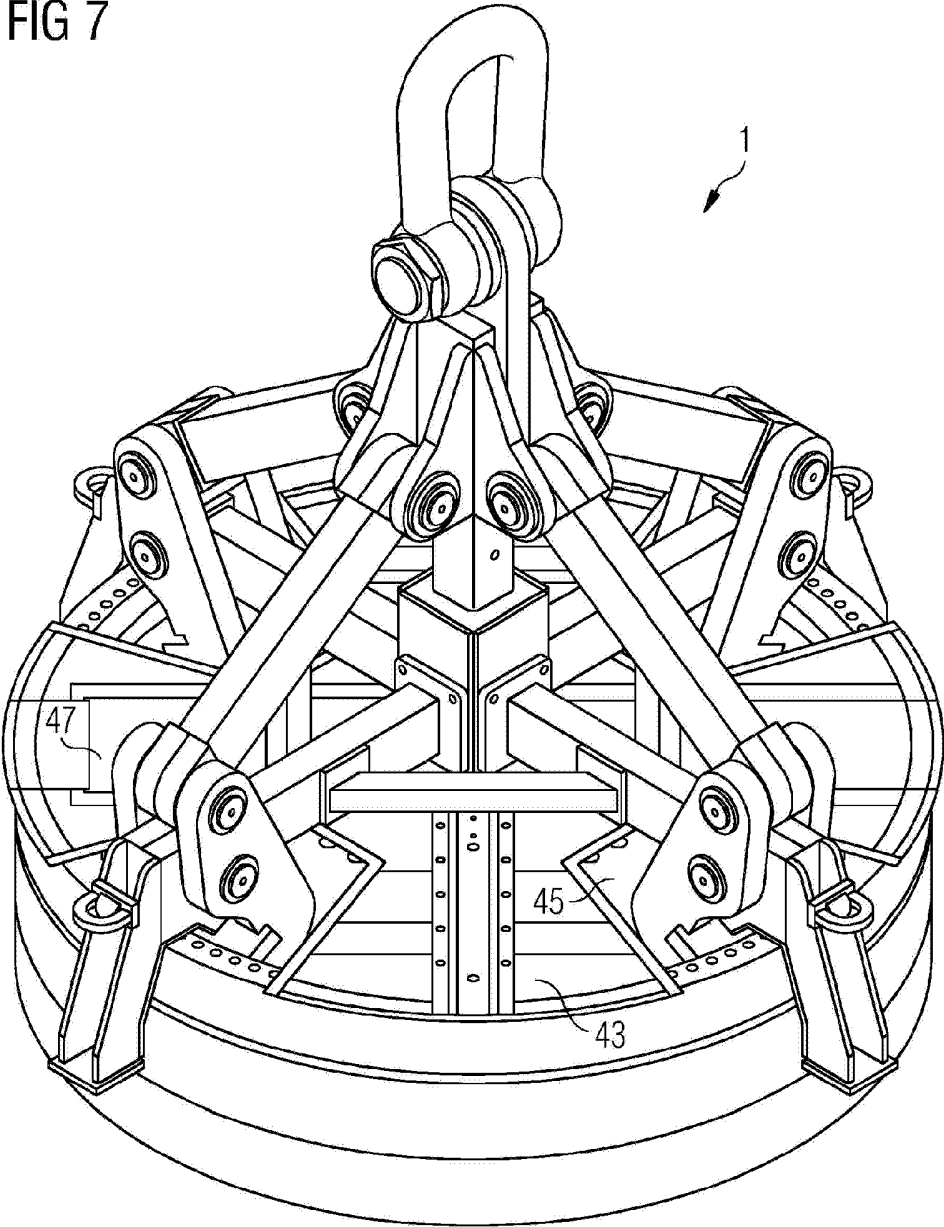

FIG 8

