

(19) World Intellectual Property Organization
International Bureau



(43) International Publication Date
14 March 2002 (14.03.2002)

PCT

(10) International Publication Number
WO 02/21746 A2

- (51) International Patent Classification⁷: H04J 14/02, H04Q 11/00 (74) Agent: DAVIS, Paul; Wilson Sonsini Goodrich & Rosati, 650 Page Mill Road, Palo Alto, CA 94034-1050 (US).
- (21) International Application Number: PCT/US01/27477 (81) Designated States (*national*): AE, AG, AL, AM, AT, AU, AZ, BA, BB, BG, BR, BY, BZ, CA, CH, CN, CO, CR, CU, CZ, DE, DK, DM, DZ, EC, EE, ES, FI, GB, GD, GE, GH, GM, HR, HU, ID, IL, IN, IS, JP, KE, KG, KP, KR, KZ, LC, LK, LR, LS, LT, LU, LV, MA, MD, MG, MK, MN, MW, MX, MZ, NO, NZ, PH, PL, PT, RO, RU, SD, SE, SG, SI, SK, SL, TJ, TM, TR, TT, TZ, UA, UG, US, UZ, VN, YU, ZA, ZW.
- (22) International Filing Date: 4 September 2001 (04.09.2001) (84) Designated States (*regional*): ARIPO patent (GH, GM, KE, LS, MW, MZ, SD, SL, SZ, TZ, UG, ZW), Eurasian patent (AM, AZ, BY, KG, KZ, MD, RU, TJ, TM), European patent (AT, BE, CH, CY, DE, DK, ES, FI, FR, GB, GR, IE, IT, LU, MC, NL, PT, SE, TR), OAPI patent (BF, BJ, CF, CG, CI, CM, GA, GN, GQ, GW, ML, MR, NE, SN, TD, TG).
- (25) Filing Language: English
- (26) Publication Language: English
- (30) Priority Data:
60/231,056 8 September 2000 (08.09.2000) US
09/715,841 17 November 2000 (17.11.2000) US
09/716,172 17 November 2000 (17.11.2000) US
- (63) Related by continuation (CON) or continuation-in-part (CIP) to earlier applications:
US 60/231,056 (CON)
Filed on 8 September 2000 (08.09.2000)
US 09/715,841 (CON)
Filed on 17 November 2000 (17.11.2000)
US 09/716,172 (CON)
Filed on 17 November 2000 (17.11.2000)
- (71) Applicant and
(72) Inventor: PARKER, Joseph, A. [US/US]; 16475 Ferris Avenue, Los Gatos, CA 95032 (US).
- Published:**
— without international search report and to be republished upon receipt of that report
- For two-letter codes and other abbreviations, refer to the "Guidance Notes on Codes and Abbreviations" appearing at the beginning of each regular issue of the PCT Gazette.*



WO 02/21746 A2

(54) Title: COMMUNICATION SYSTEM

(57) Abstract: A communication system is provided for improved data transmission. The system includes a first client (12) that includes an optical interface and at least a first optical network element (14) is coupled to the optical interface. A second optical network element (16) is coupled to the first optical network element (14). The first and second optical network elements each include a mechanism (32) for routing wavelengths under the control of the client. Also included are one or more data fibers (18) coupled to the optical interface and the first optical network element (14), and one or more control channels coupled (20) to the client (12) and the first optical network element. At least a first optical fiber (22) and a second optical fiber (24) are coupled to the first and second optical network elements. The first and second optical fibers and the first data fiber preferably support an optical path (21) between the first client and the second network element.

COMMUNICATION SYSTEM

BACKGROUND OF THE INVENTION

5

Field of the Invention

This invention relates to optical networks, and more particularly, to an all optical communication network.

10

Description of Related Art

In telecommunications, optical fiber has become one of the most successful transmission media due to its high transmission rates and low error rates. Driven by subscriber demand, network owners are currently deploying systems capable of supporting fiber for business and residential applications.

15

Many emerging telecommunication technologies require relaying traffic as quickly as possible. This idea is often called fastpacket relay or fast packet switching. Generally, the packet networks are of two types, frame relay, transporting variable sized protocol data units (PDUs), and cell relay, transporting fixed length PDUs or cells. The cell includes a 48 octet payload with a 5 octet header and is used, with slight variations, by both asynchronous transfer mode (ATM) and the Metropolitan Area Network (MAN) standard.

20

The synchronous optical network (SONET) standard defines the physical interface, optical line rates known as optical carriers (OC) signals, a frame format and an OA&M protocol. User signals are converted into a standard electrical format called the synchronous transport signal (STS), which is the equivalent to the format of the optical signal (OC).

25

30

Access networks for data communication have improved in performance and are becoming more versatile for processing images, voice, data and other information, which need transmission capacities in excess of 100 Mbs. This trend resulted in an increased demand for access networks of higher speeds and higher throughputs.

Many current access networks have a star, tree or mesh configuration. Ring topology is considered a cost-effective network architecture allowing bandwidth sharing and improved survivability in the event of span failure. Generally, a ring is formed with add/drop multiplexers (ADMs) which
5 insert/extract traffic into/from a working and a protection fiber. However, self-healing rings have a fundamental limitation. Because both protection and transmission capacities are shared among nodes, traffic increase in a saturated ring can lead to replacement of transmission equipment at all nodes, with no smooth evolutionary path for the unexpected traffic increases. A solution is to
10 use a plurality of channels on the same fiber, the channels being routed separately according to their wavelength, a technique termed wavelength division multiplexing (WDM).

WDM transmission can provide manifold capacity expansion on existing fiber links. Its potential for routing signals is equally important. By introducing
15 WDM, the capacity of a ring can be increased in an efficient and cost-effective way with a 100% multiplex section protection, and with minimal changes to the node's hardware or to the automatic switching protocol (ASP).

Networks using wavelength routing fall into two general types, single hop, which provide routes directly between nodes, and multihop, in which the
20 units of information pass through intermediate nodes. Routes in single hop networks are equivalent to independent optical fiber paths, each route using a wavelength. In multihop networks, a signal on a route may be relayed through several nodes, a number of wavelengths being used in the process. Relaying nodes may perform a store and forward function implying optoelectronic
25 conversion, or simply act as transparent crossconnects.

Single and multihop WDM network architectures have been studied. See, for example, "Dense Wavelength Division Multiplexing Networks" by C. A Brackett, IEEE Journal on Selected Areas in Communications, Vol. 8, No. 6,
1990, pp. 948-964; and "Terabit Lightwave Networks: Multihop Approach" by
30 A. S. Acampora et al., AT&T Technical Journal, Nov.-Dec. 1987, pp. 21-34.

Further discussions on local area networks are found in the following, "Dense Wavelength Division Multiplexing Networks", C.A. Brackett, IEEE Journal on Selected Areas in Communications, vol. 8, No. 6, 1990, pp. 948-964, "Terabit Lightwave Networks: Multihop Approach", A.S. Acampora et al., 5 AT&T Technical Journal, Nov.-Dec. 1987, pp. 21-34, The LambdaNet Multiwavelength Network: Architecture, Applications and Demonstrations, M. Goodman et al., IEEE Journal on Selected Areas in Communications, vol. 8, No. 6, 1990, pp. 995-1004 and "Performance Analysis of Multihop Lightwave Networks with Hot Potato Routing and Distance-Age Priorities", Z. Zhang et al., 10 IEEE Transactions on Communications, vol. 42, No. 8, Aug. 1994, pp. 2571-2581.

U.S. Patent No. 5,289,302 discloses a local area network which uses wavelength multiple rings and one special channel (wavelength) for the token passing, and uses the wavelength to segregate the switched connections.

15 A typical metropolitan or metro area can be subdivided into both an access and a core network, each with a unique set of characteristics. The core portion of current metropolitan networks face serious challenges adapting to the emergence of high bandwidth Internet Protocol (IP) services. Current core deployments are based almost exclusively on SONET ring architectures, most 20 often BLSR's. In the past, these rings have provided a cost-effective means to transport core traffic which is mainly central office (CO) to CO circuit-switched demand.

While these networks can efficiently manipulate low-bandwidths voice-oriented traffic, they become significantly less effective when faced with high- 25 capacity IP services. Today, such demand is often routed over SONET rings simply to provide the protection switching speeds that have become an essential element of many service level agreements. In areas where fiber exhaust is a concern, a problem now emerging in the metropolitan environment, these multiple overlaid SONET rings can be aggregated over a single set of fibers 30 through the use of DWDM systems. Since most of the systems commercially available today are configured as point-to-point DWDM terminals, they are

usually placed "back-to-back" for use in a SONET architecture. This complex configuration can result in considerable capital equipment outlay and the operational complications associated with multiple equipment layers.

5 Most known optical networking systems, furthermore, require a transponder or some type of optical-electrical-optical (OEO) converter between a client such as an IP router and elements in say the optical network ring. These transponders are, unfortunately, very expensive and introduce unnecessary costs and system complexity. Known systems typically require transponders to extract header and control information from the data stream. These
10 transponders are usually data rate specific and thus must be replaced everytime the optical network moves to faster data rate or transmission rate. In addition, transponders are frequently format specific (i.e. they are designed to support SONET, ATM, Gigabit Ethernet, or similar traffic). This significantly reduces the flexibility of the fabric. The requirement for transponders between IP
15 clients and the optical fabric adds to first and upgrade costs without adding functionality required by an IP-centric environment.

Accordingly, there is a need for optical networks with improved architectures that eliminate unnecessary capital equipment. There is a need for a metropolitan network that uses WDM, DWDM, or other multi-channel
20 configuration directly from the IP client. There is a further need for a metropolitan network that uses the IP client for wavelength allocation decisions. There is yet another need for a metropolitan network that simplifies node management and that implements Wavelength on Demand in milliseconds. A further need exists for a metropolitan network that readily accommodates new
25 and upgraded service requirements with Wavelength on Demand and transparent Optical Client Interfaces.

SUMMARY OF THE INVENTION

30 Accordingly, an object of the present invention is to provide an all optical communications network. Although not limited in this manner, the present invention would be of particular use in the metropolitan area.

Another object of the present invention is to provide a metropolitan network that uses DWDM channels directly from the IP client and relegates a protection switching function to the IP routers.

5 Yet another object of the present invention is to provide a metropolitan network that uses the IP client for wavelength allocation decisions.

Still another object of the present invention is to provide a metropolitan network that simplifies node management and that implements Wavelength on Demand in milliseconds.

10 Another object of the present invention is to provide a metropolitan network that readily accommodates new and upgraded service requirements with Wavelength on Demand and transparent Optical Client Interfaces.

These and other objects of the present invention are achieved in a communication system with a first client that includes an optical interface. At least a first optical network element is coupled to the optical interface. A
15 second optical network element is coupled to the first optical network element. The first and second optical network elements each include a mechanism for routing wavelengths under the control of the client. Also included are one or more data fibers coupled to the optical interface and the first optical network element, and one or more control channels coupled to the client and the first
20 optical network element. At least a first optical fiber and a second optical fiber are coupled to the first and second optical network elements. The first and second optical fibers and the first data fiber support an all optical path between the first client and the second network element.

In another embodiment of the present invention, a communication
25 system includes a first IP client with an optical interface and which runs IP protocols on a first control channel. At least a first optical network element is coupled to the optical interface. A second optical network element is coupled to the first optical network element. The first and second optical network elements each include a mechanism for routing wavelengths under the control of the
30 client. Also included are one or more data fibers coupled to the optical interface and the first optical network element, and one or more control channels coupled

to the client and the first optical network element. At least a first optical fiber and a second optical fiber are coupled to the first and second optical network elements. The first and second optical fibers and the first data fiber support an all optical path between the first client and the second network element.

5 These and other embodiments of the present invention, as well as its advantages and features, are described in more detail in conjunction with the text below and attached figures.

DESCRIPTION OF DRAWINGS

10 Figure 1A shows one embodiment of the system according to the present invention.

 Figure 1B depicts one embodiment of the system according to the present invention having an in-channel, out-of-band control channel.

15 Figure 2 shows one embodiment of the system according to the present invention using bi-directional fibers.

 Figure 3 shows a further embodiment of the system according to the present invention using bi-directional fibers and wave division multiplexing.

 Figure 4 shows one embodiment of the system according to the present invention using bi-directional fibers.

20 Figure 5 shows a system according to the present invention having counter propagation.

 Figure 6 shows a system according to the present invention having a plurality of data fibers coupled to one optical network element.

25 Figures 7A-7B show various embodiments of a switch assembly according to the present invention for use in an optical network element.

 Figure 8 depicts a further embodiment of the present invention.

 Figures 9A-9B show embodiments of an optical network element having a tunable filter for wavelength selection.

30 Figure 10 shows an embodiment of an optical network element having an optical tap.

Figures 11-12 show systems according to the present invention having a second client.

Figure 13-14B are schematics showing various embodiments of network elements according to the present invention.

5 Figure 15 is a schematic showing a system of the present invention having a ring configuration.

Figures 16A-16B show traffic routing in a system of the present invention when a fiber break occurs.

10 Figure 17 shows fiber interconnection mechanisms for use with the present invention.

DETAILED DESCRIPTION

The present invention relates generally to optical communications networks and relates in particular to all optical network communications systems. Although not limited to the following, the present invention would be of particular use in the metropolitan area. The system and methods of the present invention are particularly well adapted for networks using a plurality of channels on the same fiber, the channels being routed separately according to their wavelength, a technique termed wavelength division multiplexing (WDM). Significant cost efficiencies can be achieved by eliminating unnecessary capital equipment associated with known optical communication networks. The present invention may further provide improved transparency in the network since, in preferred embodiments, the system is bit rate and format independent. A system according to the present invention may allow for routing on a wavelength by wavelength basis.

15
20
25

Referring now to Figure 1, one embodiment of the present invention is a communication system 10 that includes a first client 12 with an optical interface 13. Examples of the first client 12 include but are not limited to an IP router with an optical signal source for sending optical communication signals. The first client 12 could also be, in particular situations, a hub with control capabilities or a SONET or WDM aggregation device with control capabilities.

30

In some embodiments, the first client 12 is preferably a control source such as for wavelength routing, restoration, or other control as required for the system 10. The first client 12 may also be the data source. The first client 12 may further be both the data source and the control source. In some embodiments, 5 the first client 12 is an edge router running Internet Engineering Task Force (IETF) IP protocols. The first client 12 may be an edge router running IETF IP protocols with an International Telecom Union (ITU) grid laser as the optical signal source for data transmission. The control signals may originate at the client, meaning that control intelligence may reside in the client unit optically 10 communicating with the first optical network element.

In a wavelength division multiplexing (WDM) system, a client 12 such as an IP router may contain a plurality of optical signal sources sending data out over different wavelength channels that are then multiplexed together. Examples of the optical interface may include but are not limited to SONET 15 Intermediate Reach optics as specified by Bellcore, at wavelengths as specified by the International Telecom Union (ITU). At least a first optical network element (ONE) 14 is coupled to the optical interface and a second optical network element (ONE) 16 coupled to first optical network element 14. Examples of suitable optical network elements may include but are not limited to 20 optical add/drop multiplexers and optical cross connects. First client 12 and second optical network element 16 are preferably coupled without optical electronic conversions for data transmission.

First and second optical network elements 14 and 16 each include a mechanism for routing wavelengths under the control of first client 12. In one 25 embodiment, these optical network elements include at least one optical optical switch that allows for selected wavelengths or lambdas to be added or dropped at the node where the optical network element is situated. These switches in the optical fabric may be of varying size such as, but not limited to, 32x32, 16x16, 8x8, or other sized switches, depending on how many wavelengths would need 30 to be dropped/routed. The system 10 may include a plurality of network elements where each element is configured to add/drop different numbers of

wavelengths, while passing the others onward. A data transport medium such as, but not limited to, one or more data fibers 18 may be coupled to the optical interface and first optical network element 14. Although other types of fibers may be used, the data fiber 18 typically comprises of a single mode or a multimode fiber. Data, data flow, data traffic, or optical communication signals on the fiber may be transported at a variety of different rates including but not limited to OC-48, OC-192, and/or OC-768. One or more control channels 20 may be coupled between first client 14 and first optical network element 12. In one embodiment, the control channel 20 is an out-of-fiber, out-of-band channel which may be used by the client 12 to monitor status of nodes, local and remote, and to control the setting up of optical paths within the fabric of the optical network elements. The term out-of-band as used herein refers to having the channel positioned on the wavelength spectrum at a wavelength slot that does not use a wavelength required for the data stream. Although not limited to the following, the control channel 20 may be embodied as a 100BaseT or OC-3 line separate from the data fiber 18 and located between the client 12 and first optical element 14. Other connections such as higher line rate optical connections or possibly Gigabit or higher rate Ethernet may also be used. It should be understood, however, that the control channel may be in some cases an in-fiber, out-of-band channel within the data fiber 18. Preferably, the control channel 20 implements a standardized protocol to permit interoperability with equipment from multiple vendors. The primary control channel 20 protocol may be the standardized version of the Optical Internetworking Forum's MPλS, GMPLS, or other protocol to provide wavelength routing commands. The system 10 may also support SNMP as an alternative protocol between client 12 and optical network elements.

A first optical transport medium 22 such as, but not limited to a first optical fiber 22, and a second optical transport medium 22 such as, but not limited to a second optical fiber 24, are coupled between first and second optical network elements 14 and 16. At least one of the fibers 22 or 24 and first data fiber 18 support an all optical path 21 between first client 12 and second

network element 16. The path 21 typically leads through the first network element 14. Referring now to Figure 1B, first control channel 20 can be one of a plurality of control channels coupled to the optical interface and first optical network element 14. Optical signals or data traffic on an all optical path does not encounter any OEO conversions which limit bit rate and format. In preferred embodiments, the control channel 20 has an operative relationship with the first data fiber wherein the control channel enables an all optical path for optical data traffic by allowing control information to be sent and interpreted without having to perform OEO conversions on the main data traffic.

In one embodiment, first client 12 can be an IP client that runs IP protocols on the first control channel 20. The system 10 typically includes an optical service channel (OSC). The OSC may be used to relay control information arriving from channel 20 to the network elements in the system. In some embodiments, the OSC uses a second protocol different from the protocol used on the control channel 20. This second protocol may be one optimized to improve the speed of connection between network elements since this second protocol is typically not limited by the desire to have some embodiments of the control channel 20 be interoperable with a variety of clients. In a preferred embodiment, the bandwidth of the OSC may be partitioned between at least two voice orderwire channels (64kB/s), two datawire channels (64kB/s), one 10Mb/s Ethernet channel and the Optical Signaling Protocol (OSP). The orderwire, Ethernet and datawire channels are for the use of craft personnel, supporting local and remote OAM&P. The Optical Signaling Protocol may be a protocol for ONE to ONE communications designed for high-speed, hardware-assisted implementation. Its capabilities are preferably designed to support and implement the commands of the control channel 20 and the additional requirements of OAM&P and optional ring restoration. Although not limited to the following, the physical layer support for the OSC may be embodied as ATM/SONET OC-3c at about 1510nm or other out-of-band control channel. The OSC preferably allows the control information relayed from client 12 along control channel 20 to be relayed to a plurality of the optical network elements

on the optical ring. This allows for, among other things, wavelength allocation along the optical ring. With multiple clients attempting to allocate wavelength channels, conflict resolution would be performed with the results relayed to the requestor.

5 First and second optical fibers 22 and 24 may be bi-directional fibers that support data flow between first optical network element 14 and second optical network element 16, and between second optical network element 16 and first optical network element 14. First and second optical fibers 22 and 24 can use wave division multiplexing to propagate data in both directions between
10 first and second optical network elements 14 and 16.

 First and second data fibers 22 and 24, and first data fiber 18 can be single or multi-mode fibers. Each control channel 20 can be a single or multi-mode mode optical fiber, wire based or wireless. Figure 1C shows the client 12 and the element 14 with wireless modules 23 and 25 for sending control signals
15 to first optical network element 14. Of course, it should be understood that the wireless modules may be incorporated into or be external to client 12 and element 14, so long as they maintain the connection of the control channel between them. Figure 1C also shows that an all optical path as indicated by arrow 21 exists between the client 12, element 14, and element 16. It should be
20 understood of course that a plurality of optical paths may exist between the elements and arrow 21 only specifically illustrates one of them.

Communication system 10 supports WDM/DWDM ring networks, linear networks and point-to-point networks. One embodiment of the present invention is a ring topology as illustrated in Figure 1 and Figures 16A/16B.

25 Referring now to Figure 2, first and second optical fibers 22 and 24 are each bi-directional fibers that support data flow between first and second optical network elements 14 and 16. In other words, data can flow bi-directionally in the same fiber between both the first and the second optical network elements. First optical fiber 22 supports signaling between first optical network element
30 14 and second optical network element 16. First optical fiber 22 may also

support signaling between second optical network element 16 and first optical network element 14 using wave division multiplexing.

In another embodiment, illustrated in Figure 3, first and second optical fibers 22 and 24 are each bi-directional fibers that support data flow between first optical network element 14 and second optical network element 16. First and second optical fibers 22 and 24 also support data flow between second optical network element 16 and the optical network element 14. First and second optical fibers 22 and 24 supporting signaling between first optical network element 14 and second optical network element 16, and second optical network element 16 and first optical network element 14 using wave division multiplexing.

As illustrated in Figure 4, first and second optical fibers 22 and 24 are again each bi-directional fibers that support data flow between first optical network element 14 and second optical network element 16, and between second optical network element 16 and first optical network element 14. First optical fiber 22 supports signaling between first optical network element 14 and second optical network element 16, and second optical fiber 24 supports signaling between second optical network element 16 and first optical network element 14.

Referring now to Figure 5, first and second optical fibers 22 and 24 provide counter propagation of data between first and second network elements 14 and 16. First optical fiber 22 supports data, data flow, data traffic, or optical communication signals between first optical network element 14 and second optical network element 16 (as indicated by arrows in Figure 5). Second optical fiber 24 supports data flow between second optical network element 16 and first optical network element 14. First optical fiber 22 supports signaling between first optical network element 14 and second optical network element 16. Second optical fiber 24 supports signaling between second optical network element 16 and first optical network element 14. Each of first data fiber 18, control channel 20, first optical fiber 22 and second optical fiber 24 can be a single mode fiber or a multi mode fiber.

As seen in Figure 5, data flow can be supported between first optical network element 16 and second optical network element 18 using WDM or DWDM. In one embodiment, first optical fiber 22 can support signaling between first optical network element 14 and second optical network element 16, and between second optical network element 16 and first optical network element 14 using WDM or DWDM. First and second optical fibers 22 and 24 can support signaling between first optical network element 14 and second optical network element 16, and between second optical network element 16 and first optical network element 14 using wave division multiplexing.

In one embodiment of system 10, first optical fiber 22 supports at least one in-fiber, out-of-band signaling channel. Second optical fiber 24 can also support one or more in-fiber, out-of-band signaling channels. First optical fiber 22 can support signaling between first optical network element 14 and second optical network element 16, and second optical fiber 24 can support signaling between second optical network element 16 and first optical network element 14.

Referring now to Figure 6, first optical network element 14 is configured to be able to route a majority of dense wavelength division multiplexing (DWDM) channels as represented by λ_1 - λ_n from first and second optical fibers 22 and 24 to first data fiber 18 and at least a second data fiber 26. Under ITU grid 100mhz spacings, n could be as high as 40. First optical network element 14 is configured to be able to route a single DWDM channel from first or second optical fibers 22 and 24 to first data fiber 18. Further, first optical network element 14 can route a single DWDM channel from first or second optical fibers 22 and 24 to first data fiber 18 and at least second data fiber 26. It should be understood that the present invention may also be used in other multi-channel configurations and is not limited to systems using DWDM wavelength spacings.

As illustrated in Figure 7A, first optical network element 14 can include a switch assembly 27 that may route a majority of DWDM channels to first and second optical fibers 22 and 24, as well as first data fiber 18 and second data

fiber 26. It should be understood of course that the optical network element 14 can be viewed as routing at least one single DWDM channel from the first and second optical fibers 22 and 24 to the first data fiber 18. First optical network element 14 can include an optical amplifier 30. Optical amplifier 30 can be an EDFA or may be some other type of amplifier as appropriate for the system. In another embodiment shown in Fig. 7B, the first element 14 has a switch that drops a plurality of wavelengths, such as λ_1 and λ_2 . The switch is coupled to first and second data fibers 18 and 26. An optical amplifier 30 may also be included in the network element 14.

Referring now to Figure 8, second optical network element 16 can route a majority of DWDM channels from first and second optical fibers 22 and 24 to second data fiber 26 which is coupled to second optical network element 16. Second optical network element 16 can also include a switch 32 that routes a majority of DWDM channels to first and second optical fibers 22 and 24 and to second data fiber 26. In this embodiment, second optical network element 16 can again include optical amplifier 30 (shown in phantom). The second optical network element 16 may also include another data fiber 29 (shown in phantom). Again, it should be understood that the present invention may also be used in other multi-channel configurations and is not limited to systems using DWDM wavelength spacings.

As seen in Figure 9A, second optical network element 16 can include a tunable filter 34. Tunable filter 34 can be an AOTF, a stretched Bragg grating or a Fabry-Perot tunable filter. An example of a tunable Fabry-Perot filter 35 is disclosed in U.S. Patent No. 5,949,801 assigned to CoreTek, Inc. of Burlington, Massachusetts, incorporated herein by reference. An optical amplifier 30 may be included in the optical network element as shown in Figure 9B. As illustrated in Figure 10, first optical network element 14 can include an opto-electronic tap 36 coupled to first optical fiber 22. Suitable opto-electronic taps 36 include but are not limited to 1% optical splitters connect to an optoelectronic converter. It should be understood that other splitters with different split percentages, such as 90/10, 80/20, or other percentages sending

the majority of the signal in one direction while tapping off some remaining portion, may also be used. Taps may also be positioned at other locations in the system, such as coupled to a data fiber 18 or on one of the other fibers.

5 In another embodiment of the present invention, shown in Figure 11, a second client 38 is coupled to first optical network element 14. The second client 38 would typically include a data fiber 40 and a control channel 42. The second optical network 16 element may have a client 50 coupled to it by a plurality of data fibers 52 and 54, and at least one and in some cases a plurality of control channels 56 and 58 (shown in phantom). Second client 38 can also be
10 coupled to second optical network element 16 as seen in Figure 12.

Second optical network element 38 can be remotely programmable by first client 12. In one embodiment, the control channel 20 relays wavelength allocation information from the client 12, which in this embodiment is an IP router. The routing information is conveyed to the first network element 14,
15 preferably via the control channel 20, and element 14 then sends the information along the OSC to the second network element 16 as needed. The OSC may provide information to the second network element on which wavelengths to drop, which to add, which wavelengths to continue, monitor and control information including EDFA power and end of life detection, fabric changes,
20 etc... The client 12 also contains intelligent decision making capacity either in the form of a electronic board, CPU, or other decision making unit that can implement intelligent restoration in case of fiber breaks or other disruption to the network. The client 12 may implement source switching to reduce backhaul and reduce restoration time to less than 50 ms.

25 Referring to the embodiment shown in Figure 13, line fibers 100 and 102 coming from a 2-fiber ring network split out Optical Supervisory Channels (preferably but not limited to about 1510 nm) and pass on the remaining data channels (preferably but not limited to about 1528nm - 1565 nm) to optical amplifiers 104 and 106 where line power (all data channels) are
30 boosted to compensate the optical losses of λ -Add/Drop Routing Fabric prior to introducing into it. Optical Supervisory Channels

typically terminated at transceivers 106 carry the status and control information that are shared among all nodes in the ring and processed by Optical Network Controller (ONC). In this embodiment, the functions of wavelength Mux/DeMux or Filtering and Add/Drop and/or Continue are taken place at λ -Add/Drop Routing Fabric that consists of various optical components such as wavelength filtering devices, optical switches and attenuators. Leaving the λ -Add/Drop Routing Fabric, added channels and pass through channels may be recombined into a single fiber and fed to another optical amplifier to boost signals for the next link. Before returning back into the line fibers of the network, data lines and Optical Supervisory Channels may be combined.

Referring to Figure 14A, one embodiment of a multi-wavelength routing fabric 110 is shown. In the embodiment of Figure 14A, the routing fabric 110 advantageously allows for dynamic add/drop of wavelengths. In other words, any wavelength can be dropped from any input to any of the associated receivers or receiver ports. Previously known devices could typically only drop a particular wavelength to the one receiver associated with that wavelength, not to any of the available receivers. In this embodiment, an NxM nonblocking optical switch 112 may be used to perform such switching. The NxM switch may be a 32x32, 16x16, 8x8 or other configuration MEMS switch. It should be understood, of course, that other optical switch technology may also be used. N may be > 4, or greater than 8, depending in part on, but not limited to, the number of wavelengths in the system. M may also be > 4. The switch may also have an asymmetric configuration such as 32x8, 16x4, or other NxM configuration. The switch 112 may be coupled to a plurality of switches via other connectors 114 (shown in phantom) to provide routing to a second receiver. An optical switch or switches in add/drop module 116 direct traffic through the network element or to a drop port or drop path to the switch 112 (for ease of illustration, only one switch such as a 2x2 switch and drop path is shown). Preferably, each switch may have a drop path to the NxM nonblocking

switch 112 which allows system access to each wavelength and routing to the desired receiver. As discussed, line fibers 100 and 102 coming from a 2-fiber ring network split out Optical Supervisory Channels (preferably but not limited to about 1510 nm) and pass on the remaining data channels (preferably but not limited to about 1528nm - 1565 nm) to optical amplifiers where line power (preferably all data channels) are boosted to compensate the optical losses of the Switch Module prior to introducing into it. Optical Supervisory Channels terminated at transceivers carry the status and control information that are shared among all nodes in the ring and processed by Optical Network Controller (ONC). Optical Amplifier 104, as part of functional unit of Signal Conditioning Module, is to compensate optical losses on the line and components. Dispersion compensation, another part of Signal Conditioning Module, is typically used to reshape the signals for some applications such as inter-node distance greater than and bit-rate at OC192. The actions of wavelength Mux/DeMux and Add/Drop and/or Continue are taken place at Switch Module or in the add/drop module that may comprise of wavelength Mux/DeMux filters, 2X2 optical switches and/or attenuators. Switch Module is responsible for functions of optical signal Mux/DeMux (DWDM), wavelength Add/Drop (λ -ADD/DROP) and also interconnection between two rings of counter traffic (Interconnection). The interconnection sub-module is responsible for traffic protection and redundancy. Leaving the Switch Module, ADD channels and pass-thru channels are recombined into a single fiber and fed to another optical amplifier to compensate for the optical loss of next link. Before returning back into the line fibers of network, data lines and Optical Supervisory Channels are recombined.

Figure 14B shows one embodiment of a second architecture for use with Add/Drop wavelength routing. The functions of wavelength Add/Drop are taken place at Tunable Module that consists of at least one wavelength Tunable filters, 2X2 optical switches, couplers and attenuators. Tunable Module is responsible for functions of wavelength Add/Drop (Tunable ADD/DROP) and also interconnection between two rings of counter traffic (Interconnection). Unlike

the embodiment of Fig. 14A, preferably, no DWDM devices are used in the embodiment of Fig 14B. The tunable filters preferably can scan across all wavelengths in the system 10 and select those that need to be dropped at the particular network element.

5 Figure 15 shows an embodiment of the system 10 wherein a second network ring 200 is coupled to the system. In this particular embodiment, a transponder 202 may be used to ensure that incoming wavelengths from other rings conform to the wavelength spacings used in the system 10. The network elements may have switch fabrics using the configurations of Fig. 14A and/or
10 14B.

 Referring now to Figures 16A and 16B, protection in the present system 10 may operate on a wavelength by wavelength basis and as a result, the protection mechanism may vary from one wavelength to the next within the same system. The wavelength by wavelength protection is enabled because
15 preferred embodiments of the present system allows each wavelength to be accessed individually through the use of mux and demuxes to break out the wavelengths and an NxM optical switch or through the tunable modules. The system architecture is designed with the capability to survive single failure without impacting traffic, and they are preferably reconfigurable within 50 msec
20 through either internal protocol or ONCI protocol from the control channel 20.

 Referring now to Figure 17, to meet the requirements of automatic protection switching, network element architectures may be designed to have an interconnection module 260 that interconnects two line fibers within a node. Shown in Figure 17 is the implementation of the module by 2x2 switches 262
25 and 264.

 While particular embodiments of the invention have been herein described in detail, it is to be appreciated that the present invention encompasses variations and combinations thereof, as may be apparent to one of ordinary skill from this disclosure. For example, the system may be at other grid spacings
30 besides those for ITU grid DWDM. It should be understood that the present invention may also be used in other multi-channel configurations and is not

limited to systems using ITU grid DWDM wavelength spacings. The system may use L-band or other frequencies instead of C-band frequencies associated with typical DWDM systems. In passing, it should be noted that the term WDM may be used to refer to both WDM and/or DWDM networks, unless otherwise noted. It is therefore to be understood that within the scope of the appended claims, the invention may be practiced otherwise than as specifically described herein.

IN THE CLAIMS

1. A communication system, comprising:
a first client (12);
5 at least a first optical network element (14) and a second optical network element (16);
at least a first data transport medium (18) coupled to the first client and the first optical network element;
at least a first control channel (20) coupled to the client and the first
10 optical network element; and
at least a first optical transport medium (22) coupled to the first and second optical network elements, wherein the first optical transport medium and the first data transport medium support an all optical path (21) between the first client and the second network element.
- 15 2. The system of claim 1 wherein each of the first and second optical network elements includes a mechanism for routing wavelengths under the control of the first client.
3. The system of claim 1, wherein data flow is supported between the first optical network element and the second optical network element using
20 wave division multiplexing.
4. The system of claim 1, wherein the first client and second optical network element are coupled without optical electronic conversions.
5. The system of claim 1, wherein the first optical fiber supports at least one in-fiber, out-of-band signaling channel.
- 25 6. The system of claim 1, wherein the first optical network element is configured to be able to route at least one single DWDM channel from the first or second optical fiber to the first data fiber or at least a second data fiber.

7. The system of claim 1, wherein the second optical network element is configured to be able to route at least one single DWDM channel from the first and second optical fibers to the first data fiber.

5 8. The system of claim 1, wherein the second optical network element is configured to be able to route at least one single DWDM channel from the first or second optical fiber to the first data fiber or at least a second data fiber.

9. The system of claim 1, wherein the first optical network element includes an opto-electronic tap coupled to the first optical fiber.

10 10. A system as in claim 1 wherein the client comprises a control source for determining wavelength routing of at least the first network element.

11. A system as in claim 1 wherein the client comprises a control source and a data source.

15 12. The system of claim 1 further comprising a second client coupled to the first optical network element.

13. The system of claim 1 further comprising a second client coupled to the second optical network element.

14. A communication system, comprising:
a first IP client (12) that includes an optical interface;
20 at least a first optical network element (14) coupled to the optical interface and a second optical network element (16) coupled to the first optical network element, each of the first and second optical network elements including a mechanism (110) for routing wavelengths under the control of the client;
25 at least a first data fiber (18) coupled to the optical interface and the first optical network element;
at least a first control channel (20) coupled to the client and the first optical network element; and

at least a first optical fiber (22) and a second optical fiber (24) coupled to the first and second optical network elements, wherein the first and second optical fibers and the first data fiber support an all optical path (21) between the first IP client and the second network element;

5 wherein said first IP client runs an IP protocol on the first control channel.

15. A communication system, comprising:

a first client (12) that includes an optical interface;

10 at least a first optical network element (14) and a second optical network element (16), wherein each of the first and second optical network elements includes a mechanism (110) under the control of the client and having a design sufficient to allow wavelengths to be allocated from any input port to any receiver port;

15 at least a first data fiber (18) coupled to the optical interface and the first optical network element;

at least a first control channel (20) coupled to the client and the first optical network element; and

20 at least a first optical fiber (22) and a second optical fiber (24) coupled to the first and second optical network elements, wherein the first and second optical fibers and the first data fiber support an all optical path (21) between the first client, the first network element, and the second network element.

16. A communication system, comprising:

a first client (12) that includes an optical interface, wherein said first client is a data source and a control source;

25 at least a first optical network element (14) and a second optical network element (16);

at least a first data fiber (18) coupled to the optical interface and the first optical network element;

30 at least a first control channel (20) coupled to the client and the first optical network element; and

at least a first optical fiber (22) and a second optical fiber (24) coupled to the first and second optical network elements, wherein the first and second optical fibers and the first data fiber support an all optical path (21) between the first client, the first network element, and the second network element, wherein data traffic passing along said path does not encounter any OEO conversions; and

said first client sending IP control signals over said first control channel to implement said all optical path, said control channel running a protocol sufficient to allow routing of data flow without requiring direct examination of the data in the data fiber, the first optical fiber, or the second optical fiber to extract header information, thus allowing for said all optical path.

17. A communication system, comprising:

a first client (12) that includes an optical interface;

at least a first optical network element (14) and a second optical network element (16), wherein each of the first and second optical network elements including a first switch directing light through the network element or to a mechanism for routing wavelengths under the control of the client, said mechanism comprising a nonblocking NxM switch (112) coupled to said first switch, wherein $N > 4$;

at least a first data fiber (18) coupled to the optical interface and the first optical network element;

at least a first control channel (20) coupled to the client and the first optical network element; and

at least a first optical fiber (22) and a second optical fiber (24) coupled to the first and second optical network elements, wherein the first and second optical fibers and the first data fiber support an all optical path (21) between the first client and the second network element.

18. A communication system, comprising:

a first IP client (12) that includes an optical interface;

at least a first optical network element (14) coupled to the optical interface and a second optical network element (16) coupled to the first optical network element;

5 at least a first data fiber (18) coupled to the optical interface and the first optical network element;

at least a first control channel (20) coupled to the client and the first optical network element; and

10 at least a first optical fiber (22) and a second optical fiber (24) coupled to the first and second optical network elements, wherein the first and second optical fibers and the first data fiber support an all optical path between the first IP client and the second network element;

wherein the first IP client runs IP protocols on the first control channel;

15 wherein the control channel has an operative relationship with said first data fiber, said operative relationship allowing for said all optical path by providing for reception and transmission of wavelength routing commands without having to convert optical data traffic in the data fiber to electrical signals to read headers in data traffic and thereby disrupt said all optical path.

19. A communication system, comprising:

a first client (12) that includes an optical interface;

20 at least a first optical network element (14) and a second optical network element (16), wherein the first optical network elements includes a mechanism (110) under the control of the client and having a design sufficient to allow wavelengths to be allocated from any input port to any receiver port;

25 at least a first data fiber (18) coupled to the optical interface and the first optical network element;

at least a first control channel (20) coupled to the client and the first optical network element; and

30 at least a first optical fiber (22) and a second optical fiber (24) coupled to the first and second optical network elements, wherein the first and second optical fibers and the first data fiber support an all optical path (21) between the first client and the second network element;

wherein the second optical network elements includes a mechanism for routing wavelengths under the control of the client, said mechanism having a tunable filter sufficient to select wavelengths in the system to route to a receiver.

20. A method comprising:

5 using IP protocol control signals to control flow of optical communication signals on an all optical data path extending from a first client, to a first network element, and to a second network element to allow for data transmission.

21. A method comprising:

10 sending data information on a first data fiber (18), said first data fiber supporting a portion of an all optical path (21) extending from a first client, to a first network element, and to a second network element;

15 sending control information containing IP protocol control signals on a control channel (20), said control channel extending from the first client to the first network element, wherein said control channel is of a design sufficient to allow data information to flow on an all optical path extending from the first client, to the first network element, and to the second network element;

said IP protocol control signals used for determining wavelength routing at said first network element and said second network element.

20 22. A method comprising:

optically coupling a client (12) to a first optical network element (14) and a second optical network element (16);

25 sending control signals along a control channel (20) extending from said client to said first optical network element, wherein said control signals originate at the client; and

sending optical communication signals carrying data from the client to at least the first network element.

23. A method comprising:

optically coupling a client (12) to a first optical network element (14) and a second optical network element (16) through said first network element to create an all optical path (21) therethrough;

5 sending control signals using a first protocol along a control channel (20) extending from said client to said first optical network element, wherein said control signals originate at the client; and

sending optical communication signals carrying data from the client to at least the first network element;

10 using a second protocol for communications between said first optical network element and said second network element.

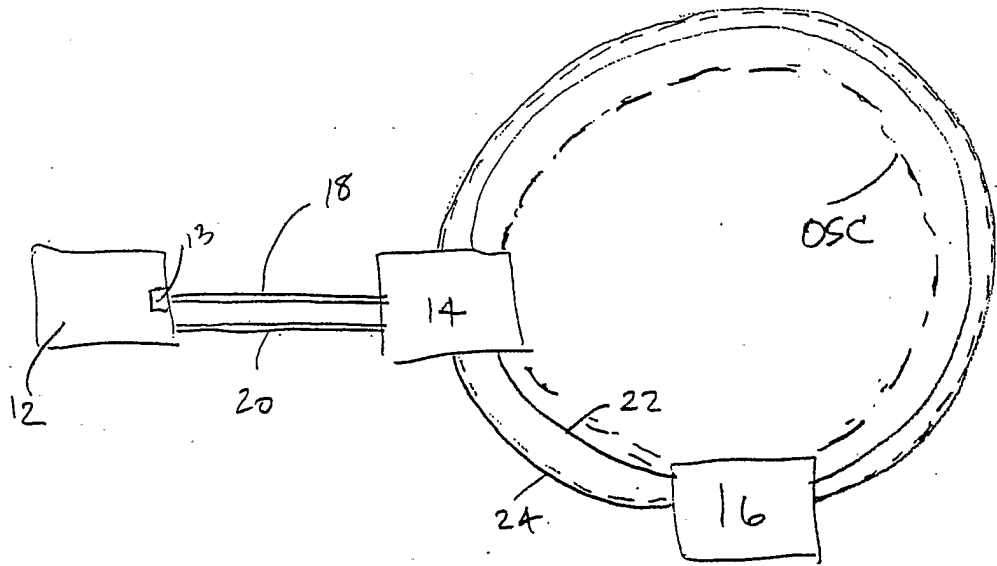

FIG_1A

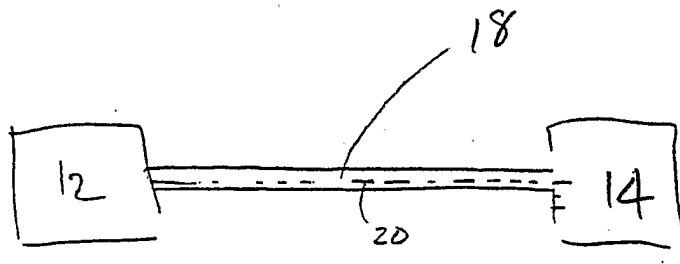

FIG_1B

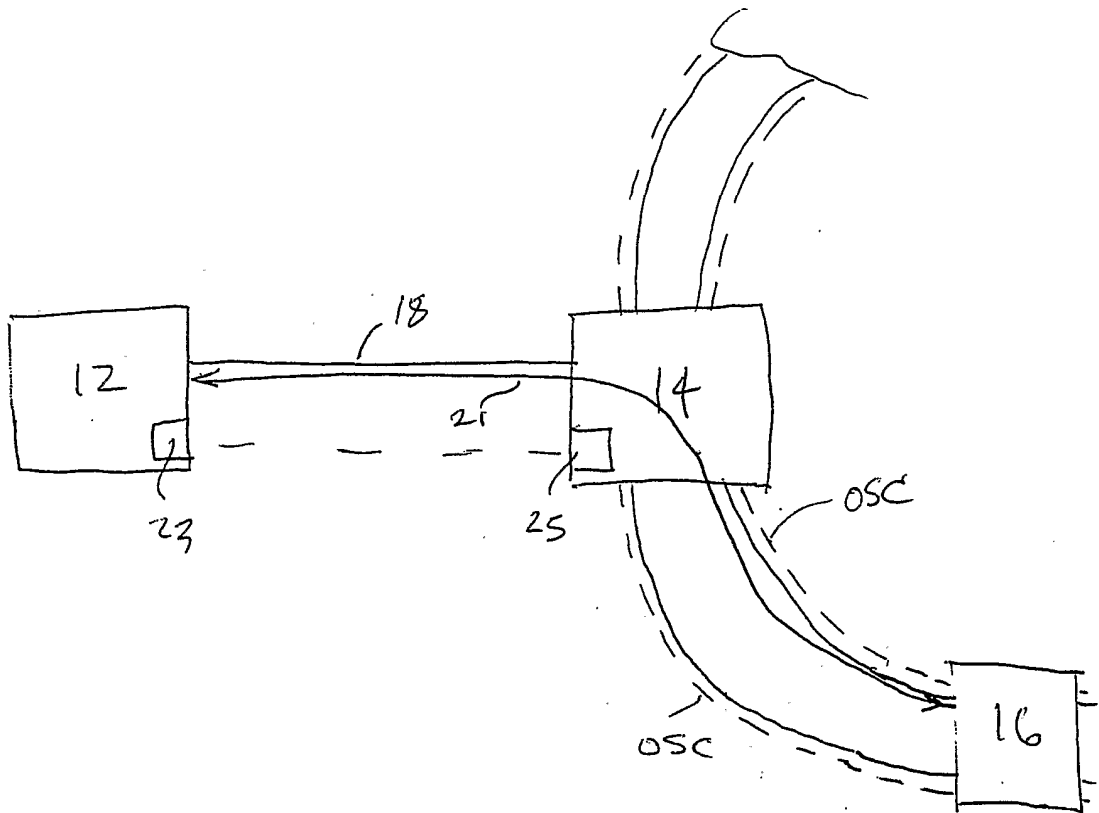

FIG 1C

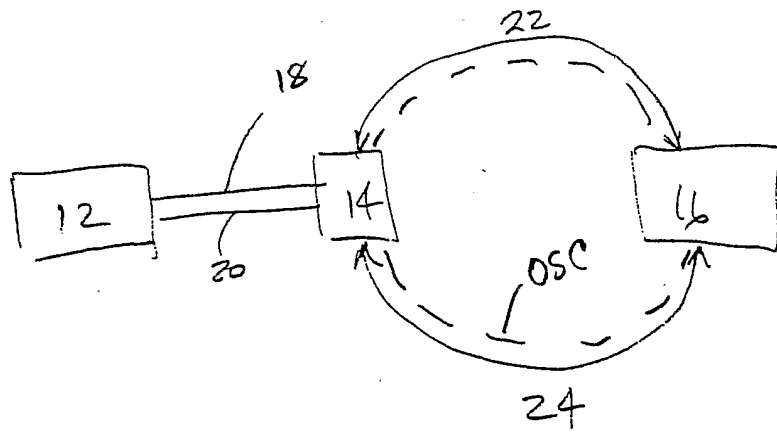

FIG - 2

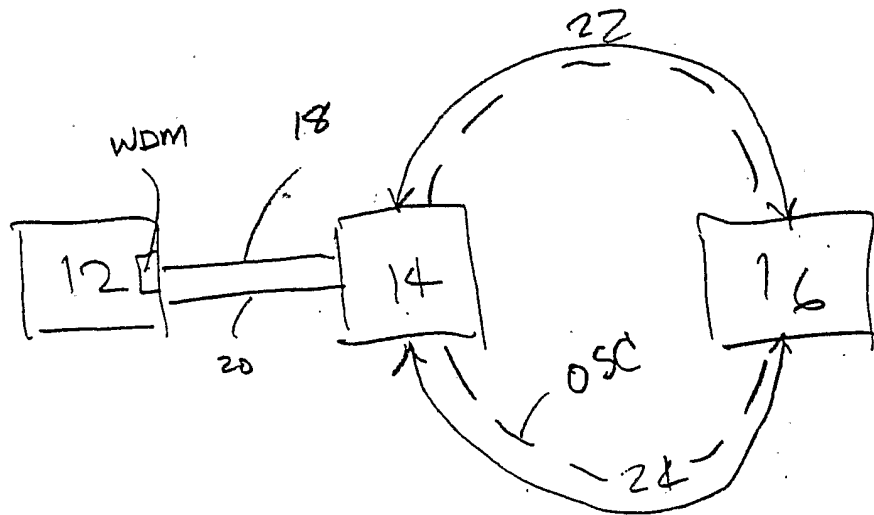
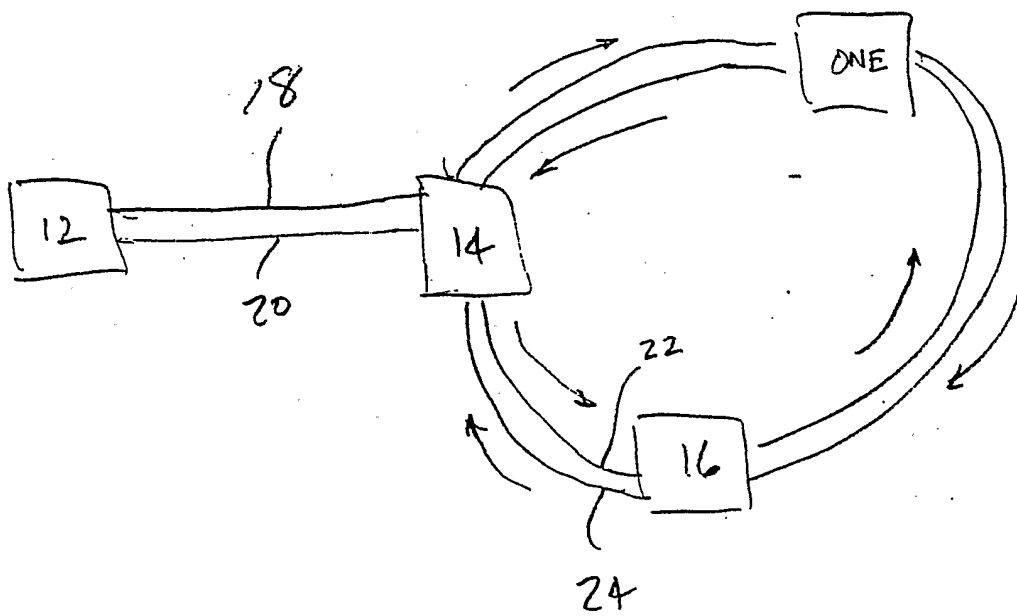
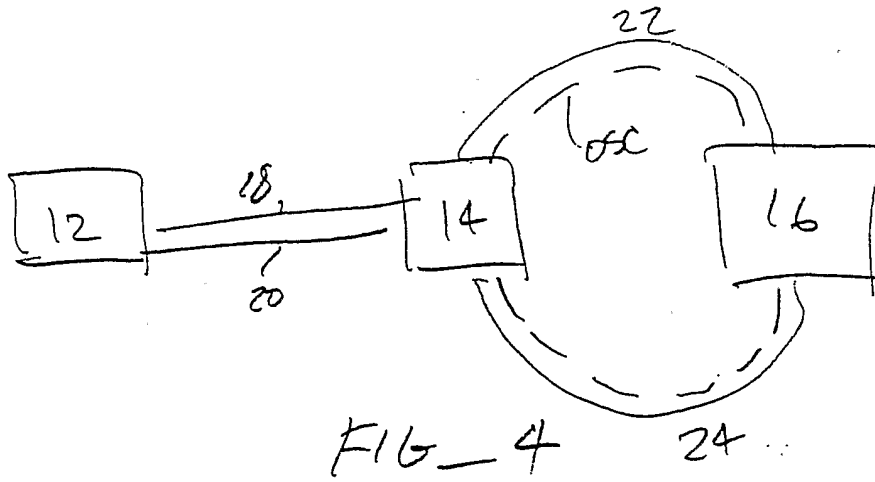

FIG - 3



FIG_5

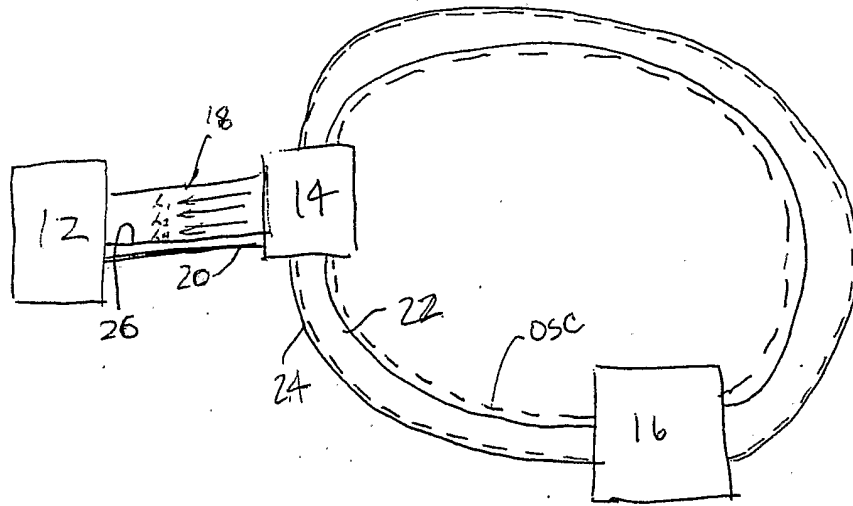

FIG - 6

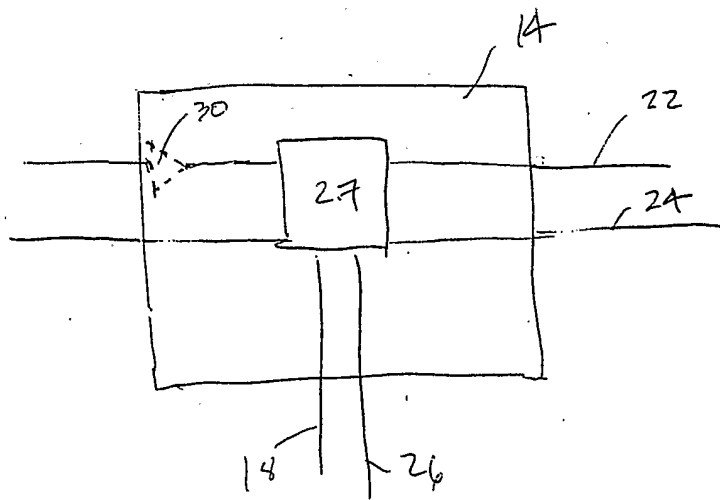

FIG - 7A

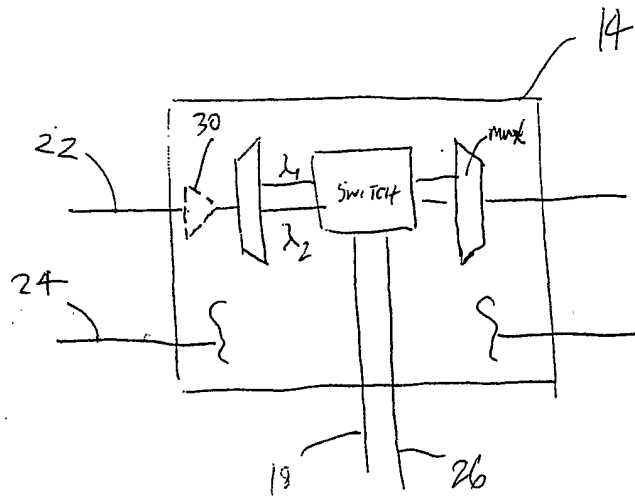

FIG - 7B

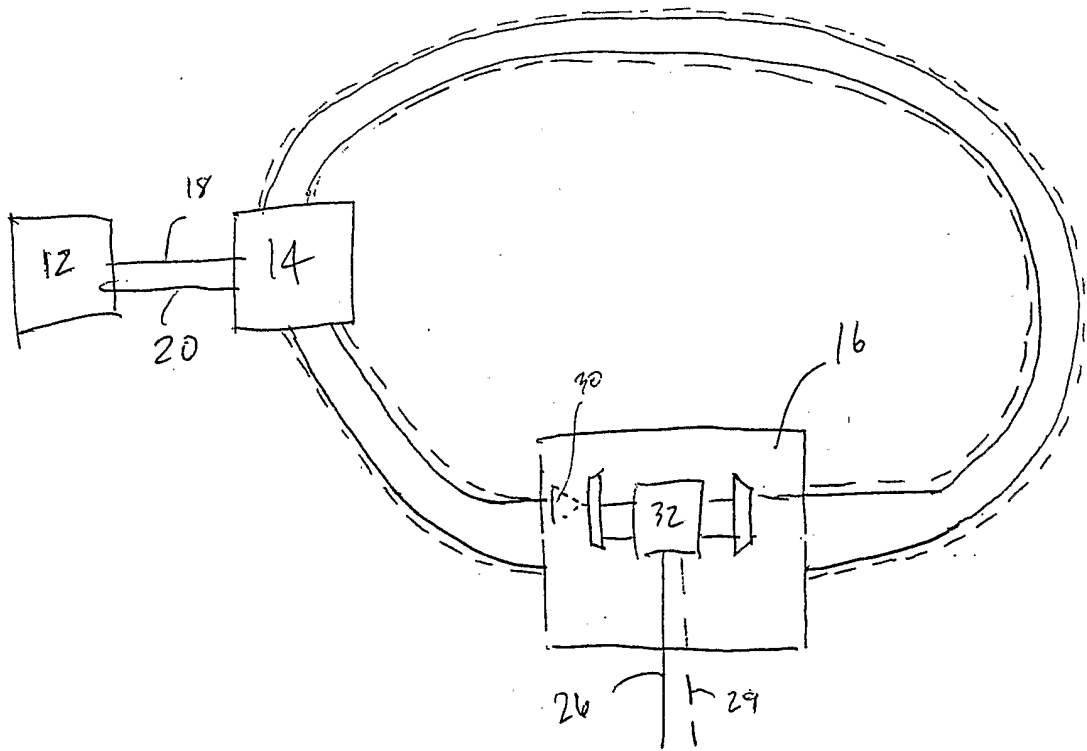

FIG - 8

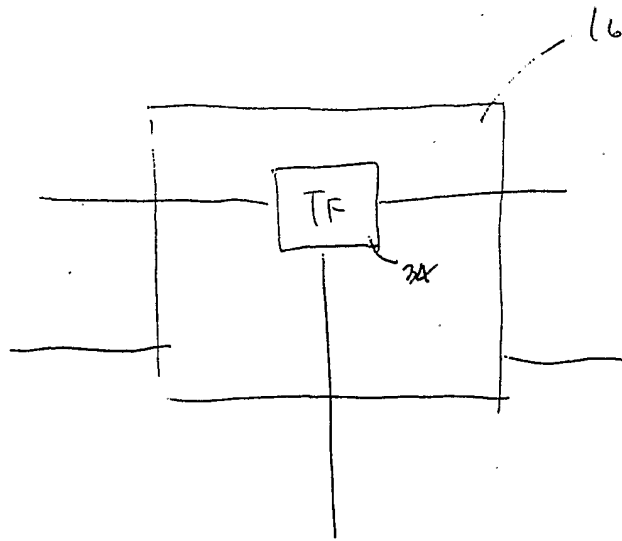

FIG-9A

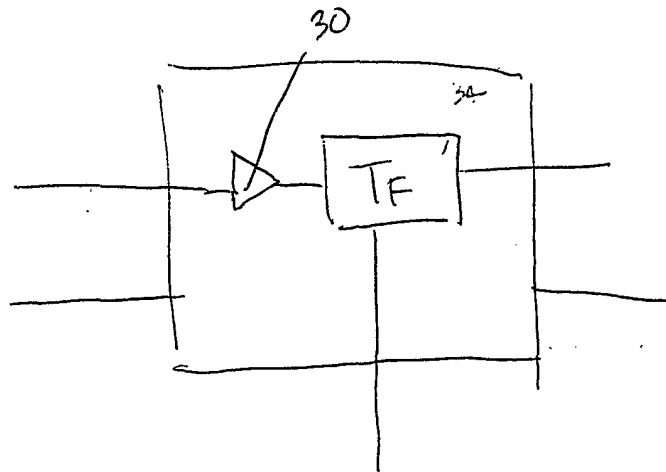

FIG-9B

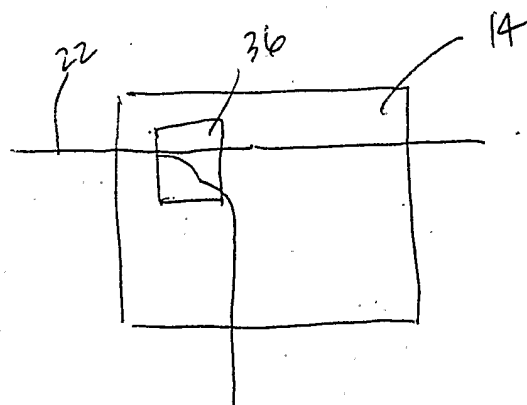
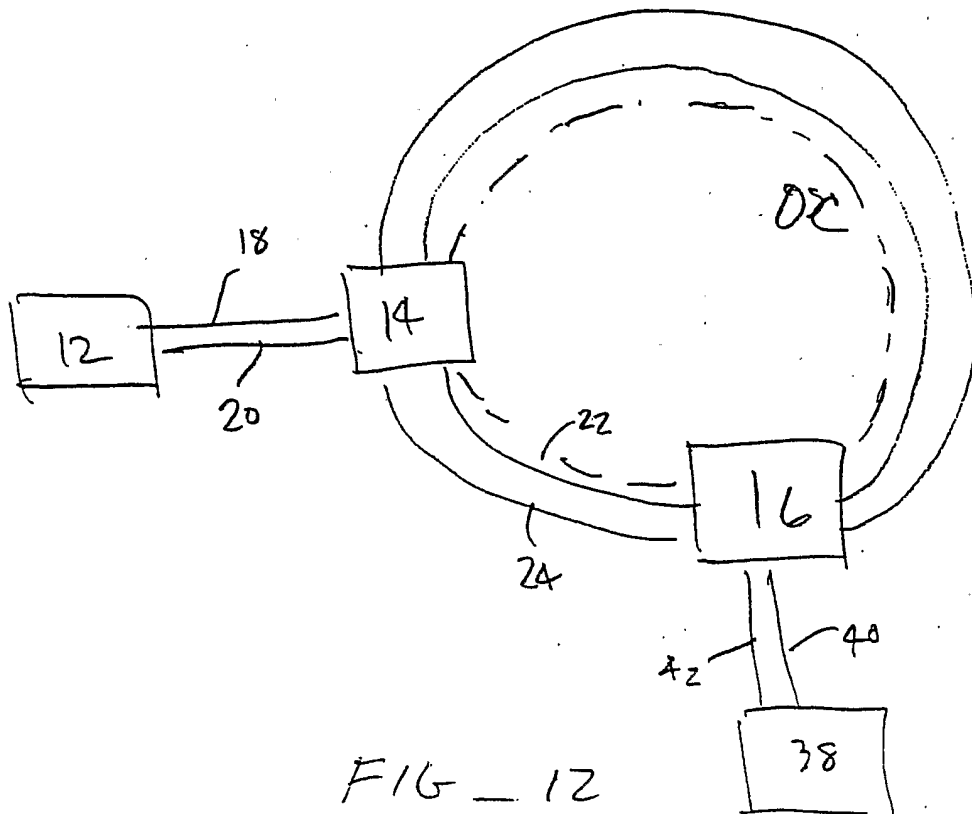
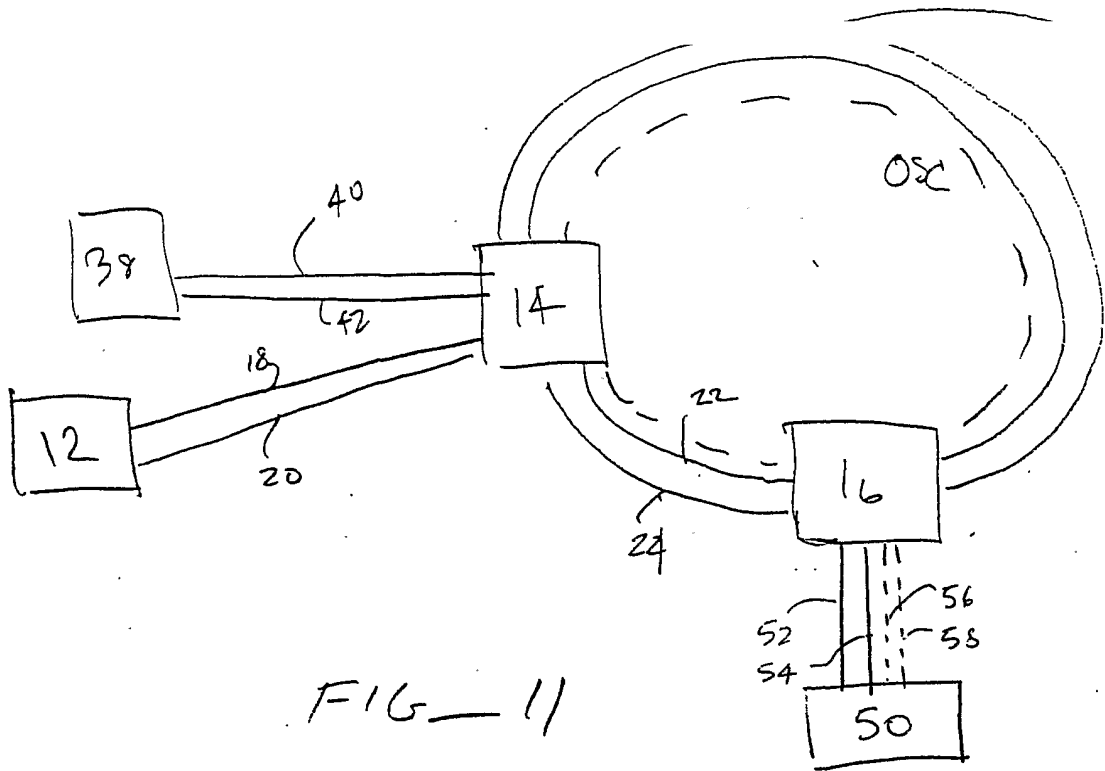

FIG-10



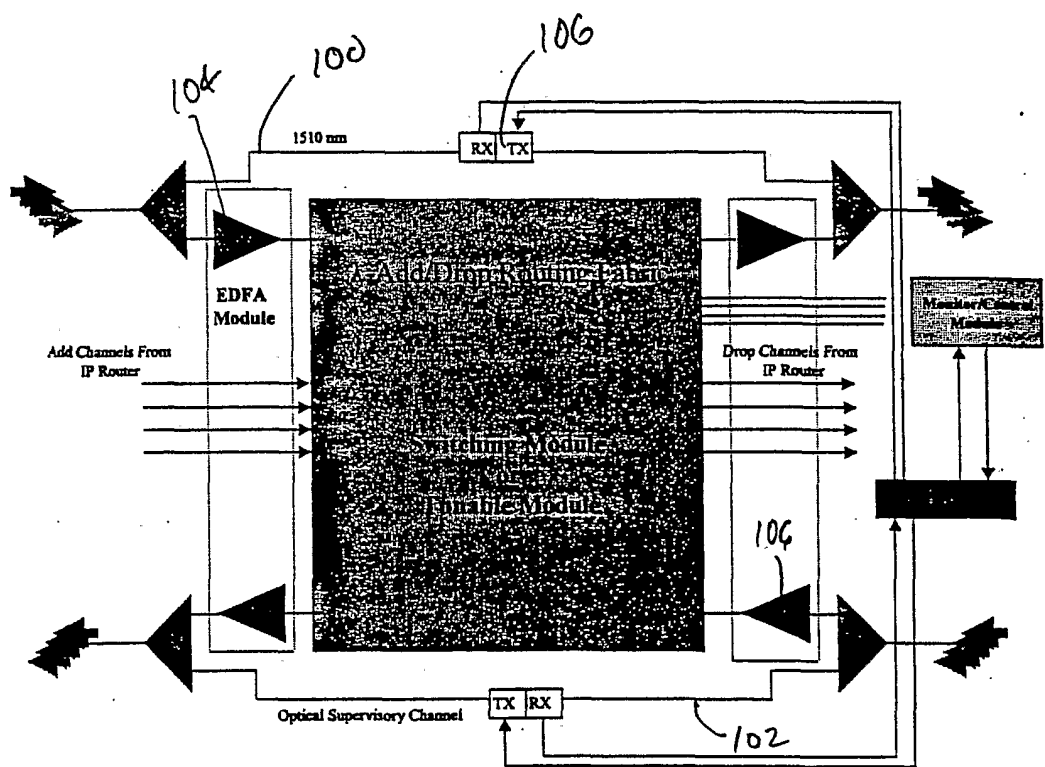

FIG - 13

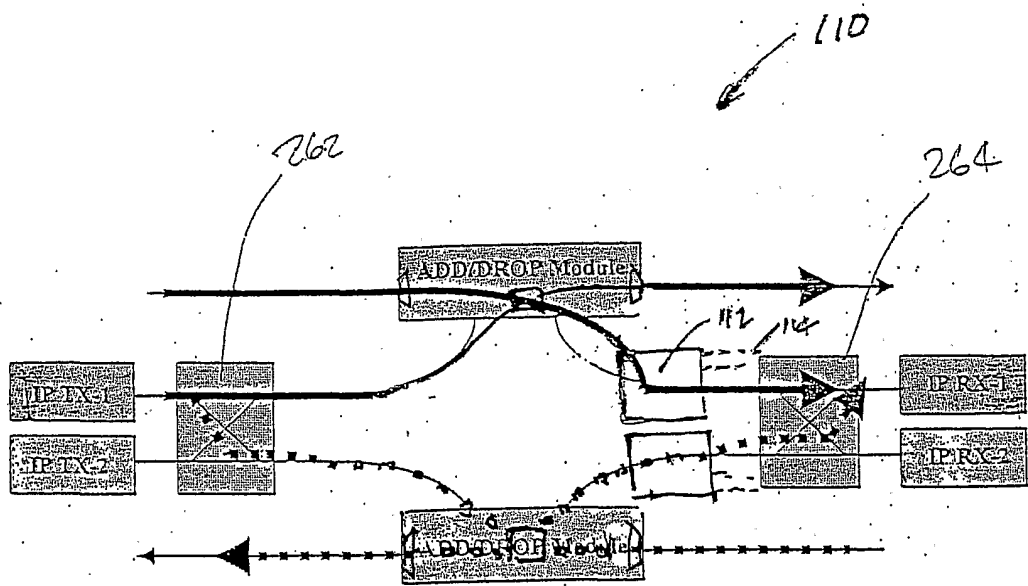

FIG-14A

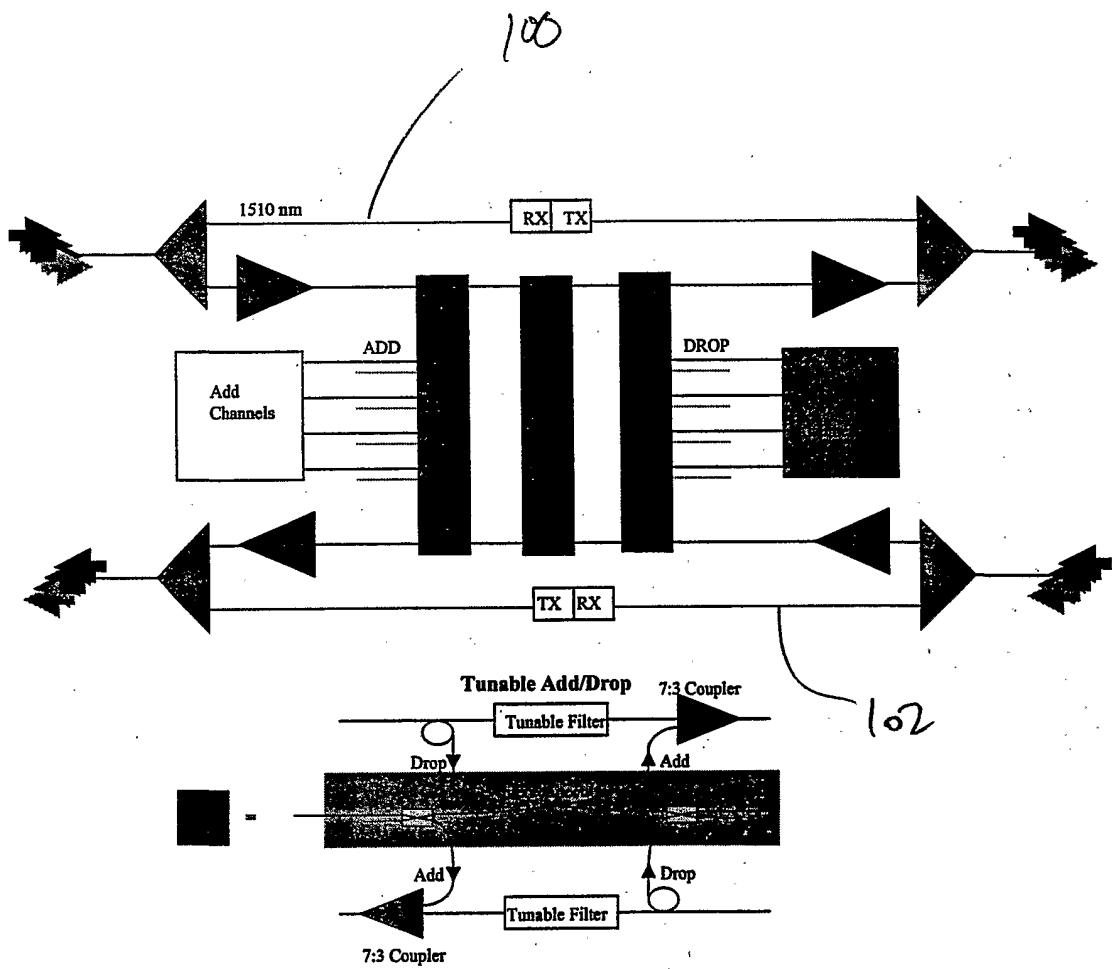

FIG. ~~14~~ 14 B

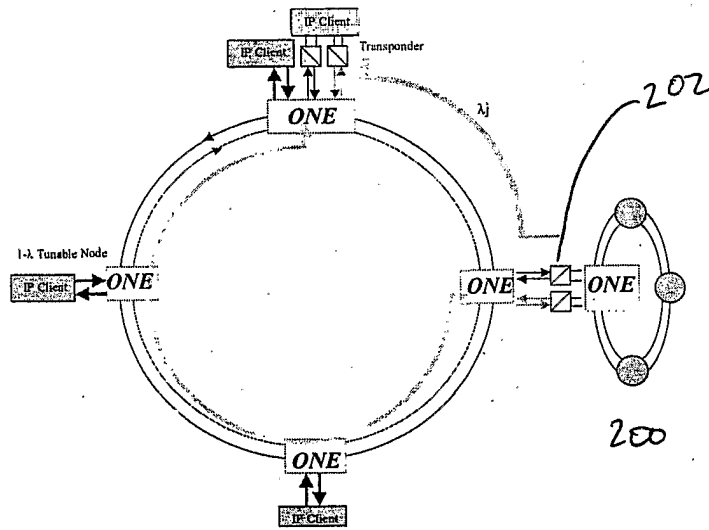

FIG-15

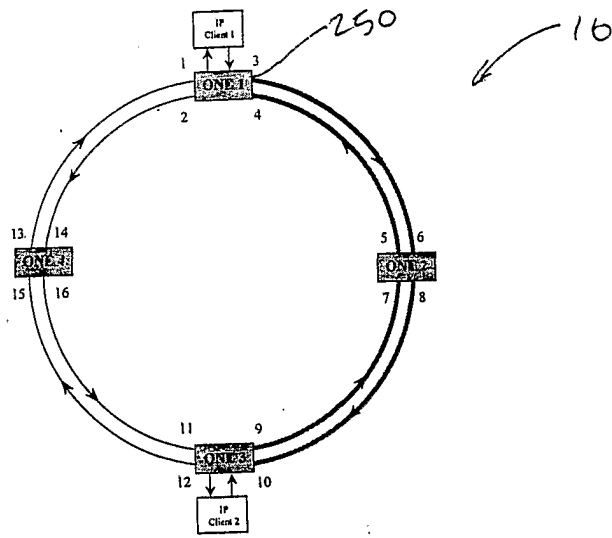

FIG-16A

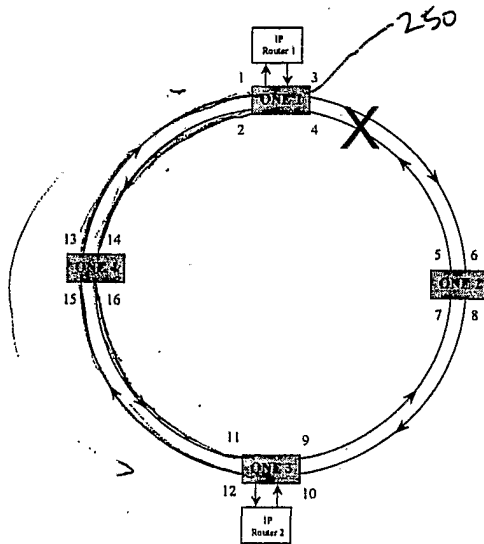

FIG-16B

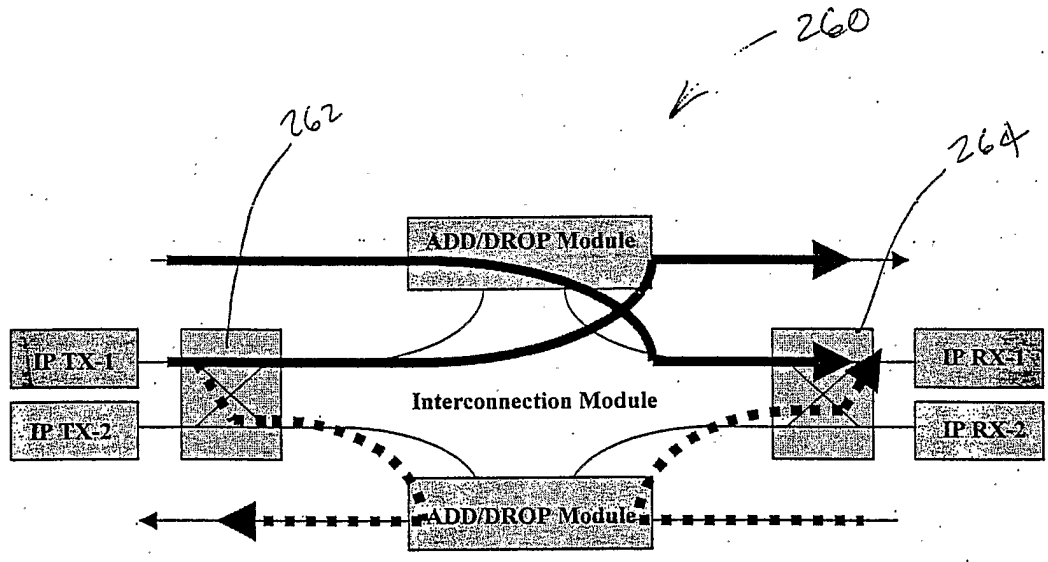

FIG-17