

Inter. Cl. **B 63B 21/00 (2018.01)**  
**B 63B 21/50 (2018.01)**  
**B 63B 22/00 (2018.01)**  
**B 63B 35/00 (2018.01)**

 N° **18204**

## FASCICULE DE BREVET D'INVENTION

21 Numéro de dépôt : 1201700153  
 PCT/US2015/057397

22 Date de dépôt : 26/10/2015

30 Priorité(s) :  
 US n° 14/524992 du 27/10/2014

24 Délivré le : 30/03/2018

45 Publié le : 17.08.2018

73 Titulaire(s) :

**Jurong Shipyard PTE Ltd.,**  
 29 Tanjong Kling Road,  
 SINGAPORE 628054 (SG);

**VANDENWORM Nicolaas Johannes,**  
 10300 Town Park Drive,  
 Suite 4099,  
 HOUSTON, Texas 77072 (US)

72 Inventeur(s) :

**VANDENWORM Nicolaas Johannes (US)**

74 Mandataire : **Cabinet ÉKÉMÉ LYSAGHT SARL,**  
 B.P. 6370, YAOUNDE (CM).

54 Titre : **Buoyant structure.**

57 Abrégé :

A buoyant structure having a hull, a main deck, an upper cylindrical side section extending downwardly from the main deck, an upper frustoconical side section, a cylindrical neck, a lower ellipsoidal section that extends from the cylindrical neck, an ellipsoidal keel and a fin-shaped appendage secured to a lower and an outer portion of the exterior of the ellipsoid keel. The upper frustoconical side section located below the upper cylindrical side section and maintained to be above a water line for a transport depth and partially below the water line for an operational depth of the buoyant structure.

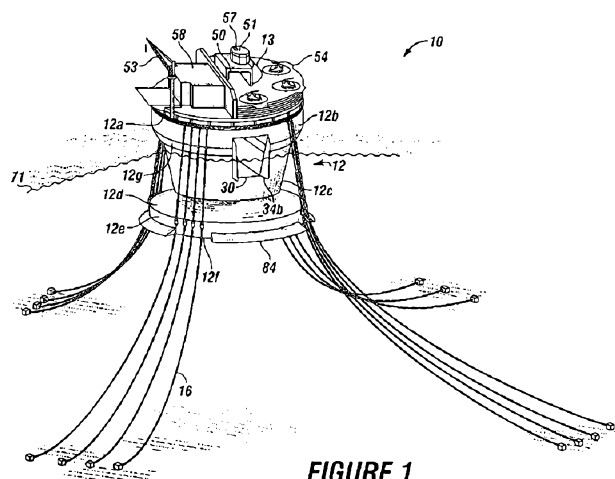


FIGURE 1

Jurong Shipyard PTE Ltd  
&  
Nicolas Johannes VANDENWORM

## TITLE: BUOYANT STRUCTURE

### CROSS REFERENCE TO RELATED APPLICATIONS

The present application claims priority to and the benefit of co-pending US Patent  
5 Application Serial No.: 14/524,992 filed on October 27, 2014, entitled "BUOYANT  
STRUCTURE," which is a Continuation in Part of issued US Patent Application Serial No.:  
14/105,321 filed on December 13, 2013, entitled "BUOYANT STRUCTURE," issued as US  
Patent No. 8,869,727 on October 28, 2014, which is a Continuation in Part of issued US  
Patent Application Serial No. 13/369,600 filed on February 09, 2012, entitled "STABLE  
10 OFFSHORE FLOATING DEPOT," issued as US Patent No. 8,662,000 on March 04,  
2014, which is a Continuation in Part of issued US Patent Application Serial No.  
12/914,709 filed on October 28, 2010, issued as US Patent No. 8,251,003 on August 28,  
2012, which claims the benefit of US Provisional Patent Application Serial No.  
61/259,201 filed on November 08, 2009 and US Provisional Patent Application Serial No.  
15 61/262,533 filed on November 18, 2009; and claims the benefit of US Provisional Patent  
Application Serial No. 61/521,701 filed on August 09, 2011, both expired. These  
references are hereby incorporated in their entirety.

### FIELD

The present embodiments generally relate to a buoyant structure for supporting offshore  
20 oil and gas operations.

### BACKGROUND

A need exists for a buoyant structure that provides kinetic energy absorption capabilities  
from a watercraft by providing a plurality of dynamic movable tendering mechanisms in a  
tunnel formed in the buoyant structure.

25 A further need exists for a buoyant structure that provides wave damping and wave  
breakup within a tunnel formed in the buoyant structure.

A need exists for a buoyant structure that provides friction forces to a hull of a watercraft

in the tunnel.

The present embodiments meet these needs.

### **BRIEF DESCRIPTION OF THE DRAWINGS**

The detailed description will be better understood in conjunction with the accompanying  
5 drawings as follows:

Figure 1 is a perspective view of a buoyant structure.

Figure 2 is a vertical profile drawing of the hull of the buoyant structure.

Figure 3 is an enlarged perspective view of the floating buoyant structure at operational  
depth.

10 Figure 4A is a top view of a plurality of dynamic moveable tendering mechanisms in a  
tunnel before a watercraft has contacted the dynamic moveable tendering mechanisms.

Figure 4B is a top view of a plurality of dynamic moveable tendering mechanisms in a  
tunnel as the hull of a watercraft has contacted the dynamic moveable tendering  
mechanisms.

15 Figure 4C is a top view of a plurality of dynamic moveable tendering mechanisms in a  
tunnel connecting to the watercraft with the doors closed.

Figure 5 is an elevated perspective view of one of the dynamic moveable tendering  
mechanisms.

Figure 6 is a collapsed top view of one of the dynamic moveable tendering mechanisms.

20 Figure 7 is a side view of an embodiment of the dynamic moveable tendering  
mechanism.

Figure 8 is a side view of another embodiment of the dynamic moveable tendering  
mechanism.

Figure 9 is a cut away view of the tunnel.

Figure 10 is a top view of a Y-shaped tunnel in the hull of the buoyant structure.

Figure 11 is a side view of the buoyant structure with a cylindrical neck.

Figure 12 is detailed view of the buoyant structure with a cylindrical neck.

Figure 13 is a cut away view of the buoyant structure with a cylindrical neck in a transport  
5 configuration.

Figure 14 is a cut away view of the buoyant structure with a cylindrical neck in an  
operational configuration.

The present embodiments are detailed below with reference to the listed Figures.

#### **DETAILED DESCRIPTION OF THE EMBODIMENTS**

10 Before explaining the present apparatus in detail, it is to be understood that the  
apparatus is not limited to the particular embodiments and that it can be practiced or  
carried out in various ways.

The present embodiments relate to a buoyant structure for supporting offshore oil and  
gas operations.

15 The embodiments enable safe entry of a watercraft into a buoyant structure in both harsh  
and benign offshore water environments, with 4 foot to 40 foot seas.

The embodiments prevent injuries to personnel from equipment falling off the buoyant  
structure by providing a tunnel to contain and protect watercraft for receiving personnel  
within the buoyant structure.

20 The embodiments provide a buoyant structure located in an offshore field that enables a  
quick exit from the offshore structure by many personnel simultaneously, in the case of  
an approaching hurricane or tsunami.

The embodiments provide a means to quickly transfer many personnel, such as from 200  
to 500 people safely from an adjacent platform on fire to the buoyant structure in less  
25 than 1 hour.

The embodiments enable the offshore structure to be towed to an offshore disaster and operate as a command center to facilitate in the control of a disaster, and can act as a hospital, or triage center.

Turning now to the Figures, Figure 1 depicts a buoyant structure for operationally supporting offshore exploration, drilling, production, and storage installations according to an embodiment of the invention.

The buoyant structure 10 can include a hull 12, which can carry a superstructure 13 thereon. The superstructure 13 can include a diverse collection of equipment and structures, such as living quarters and crew accommodations 58, equipment storage, a heliport 54, and a myriad of other structures, systems, and equipment, depending on the type of offshore operations to be supported. Cranes 53 can be mounted to the superstructure. The hull 12 can be moored to the seafloor by a number of catenary mooring lines 16. The superstructure can include an aircraft hangar 50. A control tower 51 can be built on the superstructure. The control tower can have a dynamic position system 57.

The buoyant structure 10 can have a tunnel 30 with a tunnel opening in the hull 12 to locations exterior of the tunnel.

The tunnel 30 can receive water while the buoyant structure 10 is at an operational depth 71.

The buoyant structure can have a unique hull shape.

Referring to Figures 1 and 2, the hull 12 of the buoyant structure 10 can have a main deck 12a, which can be circular; and a height H. Extending downwardly from the main deck 12a can be an upper frustoconical portion 14.

In embodiments, the upper frustoconical portion 14 can have an upper cylindrical side section 12b extending downwardly from the main deck 12a, an inwardly-tapering upper frustoconical side section 12g located below the upper cylindrical side section 12b and connecting to a lower inwardly-tapering frustoconical side section 12c.

The buoyant structure 10 also can have a lower frustoconical side section 12d extending

downwardly from the lower inwardly-tapering frustoconical side section 12c and flares outwardly. Both the lower inwardly-tapering frustoconical side section 12c and the lower frustoconical side section 12d can be below the operational depth 71.

5 A lower ellipsoidal section 12e can extend downwardly from the lower frustoconical side section 12d, and a matching ellipsoidal keel 12f.

The lower inwardly-tapering frustoconical side section 12c can have a substantially greater vertical height H1 than lower frustoconical side section 12d shown as H2. Upper cylindrical side section 12b can have a slightly greater vertical height H3 than lower ellipsoidal section 12e shown as H4.

10 As shown, the upper cylindrical side section 12b can connect to inwardly-tapering upper frustoconical side section 12g so as to provide for a main deck of greater radius than the hull radius along with the superstructure 13, which can be round, square or another shape, such as a half moon. Inwardly-tapering upper frustoconical side section 12g can be located above the operational depth 71.

15 The tunnel 30 can have at least one closable door 34a and 34b that alternatively or in combination, can provide for weather and water protection to the tunnel 30.

Fin-shaped appendages 84 can be attached to a lower and an outer portion of the exterior of the hull.

20 The hull 12 is depicted with a plurality of catenary mooring lines 16 for mooring the buoyant structure to create a mooring spread.

Figure 2 is a simplified view of a vertical profile of the hull according to an embodiment.

The tunnel 30 can have a plurality of dynamic movable tendering mechanisms 24d and 24h disposed within and connected to the tunnel sides.

25 In an embodiment, the tunnel 30 can have closable doors 34a and 34b for opening and closing the tunnel opening 31.

The tunnel floor 35 can accept water when the buoyant structure is at an operational

depth 71.

Two different depths are shown, the operational depth 71 and the transit depth 70.

The dynamic movable tendering mechanisms 24d and 24h can be oriented above the tunnel floor 35 and can have portions that are positioned both above the operational  
5 depth 71 and extend below the operational depth 71 inside the tunnel 30.

The main deck 12a, upper cylindrical side section 12b, inwardly-tapering upper frustoconical side section 12g, lower inwardly-tapering frustoconical side section 12c, lower frustoconical side section 12d, lower ellipsoidal section 12e, and matching  
10 ellipsoidal keel 12f are all co-axial with a common vertical axis 100. In embodiments, the hull 12 can be characterized by an ellipsoidal cross section when taken perpendicular to the vertical axis 100 at any elevation.

Due to its ellipsoidal planform, the dynamic response of the hull 12 is independent of wave direction (when neglecting any asymmetries in the mooring system, risers, and underwater appendages), thereby minimizing wave-induced yaw forces. Additionally, the  
15 conical form of the hull 12 is structurally efficient, offering a high payload and storage volume per ton of steel when compared to traditional ship-shaped offshore structures. The hull 12 can have ellipsoidal walls which are ellipsoidal in radial cross-section, but such shape may be approximated using a large number of flat metal plates rather than bending plates into a desired curvature. Although an ellipsoidal hull planform is preferred,  
20 a polygonal hull planform can be used according to alternative embodiments.

In embodiments, the hull 12 can be circular, oval or elliptical forming the ellipsoidal planform.

An elliptical shape can be advantageous when the buoyant structure is moored closely adjacent to another offshore platform so as to allow gangway passage between the two  
25 structures. An elliptical hull can minimize or eliminate wave interference.

The specific design of the lower inwardly-tapering frustoconical side section 12c and the lower frustoconical side section 12d generates a significant amount of radiation damping resulting in almost no heave amplification for any wave period, as described below.

Lower inwardly-tapering frustoconical side section 12c can be located in the wave zone. At operational depth 71, the waterline can be located on lower inwardly-tapering frustoconical side section 12c just below the intersection with upper cylindrical side section 12b. Lower inwardly-tapering frustoconical side section 12c can slope at an angle (□□□ with respect to the vertical axis 100 from 10 degrees to 15 degrees. The inward flare before reaching the waterline significantly dampens downward heave, because a downward motion of the hull 12 increases the waterplane area. In other words, the hull area normal to the vertical axis 100 that breaks the water's surface will increase with downward hull motion, and such increased area is subject to the opposing resistance of the air and or water interface. It has been found that 10 degrees to 15 degrees of flare provides a desirable amount of damping of downward heave without sacrificing too much storage volume for the vessel.

Similarly, lower frustoconical side section 12d dampens upward heave. The lower frustoconical side section 12d can be located below the wave zone (about 30 meters below the waterline). Because the entire lower frustoconical side section 12d can be below the water surface, a greater area (normal to the vertical axis 100) is desired to achieve upward damping. Accordingly, the first diameter  $D_1$  of the lower hull section can be greater than the second diameter  $D_2$  of the lower inwardly-tapering frustoconical side section 12c. The lower frustoconical side section 12d can slope at an angle (□□ with respect to the vertical axis 100 from 55 degrees to 65 degrees. The lower section can flare outwardly at an angle greater than or equal to 55 degrees to provide greater inertia for heave roll and pitch motions. The increased mass contributes to natural periods for heave pitch and roll above the expected wave energy. The upper bound of 65 degrees is based on avoiding abrupt changes in stability during initial ballasting on installation. That is, lower frustoconical side section 12d can be perpendicular to the vertical axis 100 and achieve a desired amount of upward heave damping, but such a hull profile would result in an undesirable step-change in stability during initial ballasting on installation. The connection point between upper frustoconical portion 14 and the lower frustoconical side section 12d can have a third diameter  $D_3$  smaller than the first and second diameters  $D_1$  and  $D_2$ .

The transit depth 70 represents the waterline of the hull 12 while it is being transited to an operational offshore position. The transit depth is known in the art to reduce the amount

of energy required to transit a buoyant vessel across distances on the water by decreasing the profile of buoyant structure which contacts the water. The transit depth is roughly the intersection of lower frustoconical side section 12d and lower ellipsoidal section 12e. However, weather and wind conditions can provide need for a different transit depth to meet safety guidelines or to achieve a rapid deployment from one position on the water to another.

In embodiments, the center of gravity of the offshore vessel can be located below its center of buoyancy to provide inherent stability. The addition of ballast to the hull 12 is used to lower the center of gravity. Optionally, enough ballast can be added to lower the center of gravity below the center of buoyancy for whatever configuration of superstructure and payload is to be carried by the hull 12.

The hull is characterized by a relatively high metacenter. But, because the center of gravity (CG) is low, the metacentric height is further enhanced, resulting in large righting moments. Additionally, the peripheral location of the fixed ballast further increases the righting moments.

The buoyant structure aggressively resists roll and pitch and is said to be "stiff." Stiff vessels are typically characterized by abrupt jerky accelerations as the large righting moments counter pitch and roll. However, the inertia associated with the high total mass of the buoyant structure, enhanced specifically by the fixed ballast, mitigates such accelerations. In particular, the mass of the fixed ballast increases the natural period of the buoyant structure to above the period of the most common waves, thereby limiting wave-induced acceleration in all degrees of freedom.

In an embodiment, the buoyant structure can have thrusters 99a-99d.

Figure 3 shows the buoyant structure 10 with the main deck 12a and the superstructure 13 over the main deck.

In embodiments, the crane 53 can be mounted to the superstructure 13, which can include a heliport 54.

In this view a watercraft 200 is in the tunnel having come into the tunnel through the tunnel opening 30 and is positioned between the tunnel sides, of which tunnel side 202 is

labeled. A boat lift 41 is also shown in the tunnel, which can raise the watercraft above the operational depth in the tunnel.

5 The tunnel opening 30 is shown with two doors, each door having a door fender 36a and 36b for mitigating damage to a watercraft attempting to enter the tunnel, but not hitting the doors.

The door fenders can allow the watercraft to impact the door fenders safely if the pilot cannot enter the tunnel directly due to at least one of large wave and high current movement from a location exterior of the hull.

10 The catenary mooring lines 16 are shown coming from the upper cylindrical side section 12b.

A berthing facility 60 is shown in the hull 12 in the portion of the inwardly-tapering upper frustoconical side section 12g. The inwardly-tapering upper frustoconical side section 12g is shown connected to the lower inwardly-tapering frustoconical side section 12c and the upper cylindrical side section 12b.

15 Figure 4A shows the watercraft 200 entering the tunnel between tunnel sides 202 and 204 and connecting to the plurality of dynamic movable tendering mechanisms 24a-24h. Proximate to the tunnel opening are closable doors 34a and 34b which can be sliding pocket doors to provide either a weather tight or water tight protection of the tunnel from the exterior environment. The starboard side 206 hull and port side 208 hull of the  
20 watercraft are also shown.

Figure 4B shows the watercraft 200 inside a portion of the tunnel between tunnel sides 202 and 204 and connecting to the plurality of dynamic movable tendering mechanisms 24a-24h. Dynamic moveable tendering mechanisms 24g and 24h are shown contacting the port side 208 hull of the watercraft 200. Dynamic moveable tendering mechanisms  
25 24c and 24d are seen contacting the starboard side 206 hull of the watercraft 200. The closable doors 34a and 34b are also shown.

Figure 4C shows the watercraft 200 in the tunnel between tunnel sides 202 and 204 and connecting to the plurality of dynamic movable tendering mechanisms 24a-24h and also connected to a gangway 77. Proximate to the tunnel opening are closable doors 34a and

34b which can be sliding pocket doors oriented in a closed position providing either a weather tight or water tight protection of the tunnel from the exterior environment. The plurality of the dynamic moveable tendering mechanisms 24a-24h are shown in contact with the hull of the watercraft on both the starboard side 206 and port side 208.

- 5 Figure 5 shows one of the plurality of the dynamic movable tendering mechanisms 24a. Each dynamic movable tendering mechanism can have a pair of parallel arms 39a and 39b mounted to a tunnel side, shown as tunnel side 202 in this Figure.

A fender 38a can connect to the pair of parallel arm 39a and 39b on the sides of the parallel arms opposite the tunnel side.

- 10 A plate 43 can be mounted to the pair of parallel arms 39a and 39b and between the fender 38a and the tunnel side 202.

The plate 43 can be mounted above the tunnel floor 35 and positioned to extend above the operational depth 71 in the tunnel and below the operational depth 71 in the tunnel simultaneously.

- 15 The plate 43 can be configured to dampen movement of the watercraft as the watercraft moves from side to side in the tunnel. The plate and entire dynamic movable tendering mechanism can prevent damage to the ship hull, and push a watercraft away from a ship hull without breaking towards the tunnel center. The embodiments can allow a vessel to bounce in the tunnel without damage.

- 20 A plurality of pivot anchors 44a and 44b can connect one of the parallel arms to the tunnel side.

- Each pivot anchor can enable the plate to swing from a collapsed orientation against the tunnel sides to an extended orientation at an angle  $\theta$ , which can be up to 90 degrees from a plane 61 of the wall enabling the plate on the parallel arm and the fender to simultaneously (i) shield the tunnel from waves and water sloshing effects, (ii) absorb kinetic energy of the watercraft as the watercraft moves in the tunnel, and (iii) apply a force to push against the watercraft keeping the watercraft away from the side of the tunnel.
- 25

A plurality of fender pivots 47a and 47b are shown, wherein each pivot can form a connection between each parallel arm and the fender 38a, each fender pivot can allow the fender to pivot from one side of the parallel arm to an opposite side of the parallel arm through at least 90 degrees as the watercraft contacts the fender 38a.

- 5 A plurality of openings 52a-52ae in the plate 43 can reduce wave action. Each opening can have a diameter from 0.1 meters to 2 meters. In embodiments, the openings 52 can be ellipses.

At least one hydraulic cylinder 28a and 28b can be connected to each parallel arm for providing resistance to watercraft pressure on the fender and for extending and retracting  
10 the plate from the tunnel sides.

Figure 6 shows one of the pair of parallel arms 39a mounted to a tunnel side 202 in a collapsed position.

The parallel arm 39a can be connected to the pivot anchor 44a that engages the tunnel side 202.

- 15 Fender pivot 47a can be mounted on the parallel arm opposite the anchor pivot.

The fender 38a can be mounted to the fender pivot 47a.

The plate 43 can be attached to the parallel arm 39a.

The hydraulic cylinder 28a can be attached to the parallel arm and the tunnel wall.

- Figure 7 shows the plate 43 with openings 52a-52ag that can be ellipsoidal in shape,  
20 wherein the plate is shown mounted above the tunnel floor 35.

The plate can extend both above and below the operational depth 71.

The tunnel side 202, pivot anchors 44a and 44b, parallel arms 39a and 39b, fender pivots 47a and 47b, and fender 38a are also shown.

- Figure 8 shows an embodiment of a dynamic moveable tendering mechanism formed  
25 from a frame 74 instead of the plate. The frame 74 can have intersecting tubulars 75a and 75b that form openings 76a and 76b for allowing water to pass while water in the

tunnel is at an operational depth 71.

The tunnel side 202, tunnel floor 35, pivot anchors 44a and 44b, parallel arms 39a and 39b, fender pivots 47a and 47b, and fender 38a are also shown.

5 Figure 9 shows the tunnel floor 35 having lower tapering surfaces 73a and 73b at an entrance of the tunnel, providing a "beach effect" that absorbs surface wave energy effect inside of the tunnel. The lower tapering surfaces can be at an angle 78a and 78b that is from 3 degrees to 40 degrees.

10 Two fenders 38h and 38d can be mounted between two pairs of parallel arms. Fender 38h can be mounted between parallel arms 39o and 39p, and fender 38d can be mounted between parallel arms 39g and 39h.

In embodiments, the pair of parallel arms can be simultaneously extendable and retractable.

The tunnel walls 202 and 204 are also shown.

15 Figure 10 shows a Y-shaped configuration from a top cutaway view of the hull 12 with the tunnel 30 with the tunnel opening 31, in communication with a branch 33a and branch 33b going to additional openings 32a and 32b respectively.

The buoyant structure can have a transit depth and an operational depth, wherein the operational depth is achieved using ballast pumps and filling ballast tanks in the hull with water after moving the structure at transit depth to an operational location.

20 The transit depth can be from about 7 meters to about 15 meters, and the operational depth can be from about 45 meters to about 65 meters. The tunnel can be out of water during transit.

Straight, curved, or tapering sections in the hull can form the tunnel.

In embodiments, the plates, closable doors, and hull can be made from steel.

25 Figure 11 is a side view of the buoyant structure with a cylindrical neck.

The buoyant structure 10 is shown having a hull 12 with a main deck 12a.

The buoyant structure 10 has an upper cylindrical side section 12b extending downwardly from the main deck 12a and an upper frustoconical side section 12g extending from the upper cylindrical side section 12b.

- 5 The buoyant structure 10 has a cylindrical neck 8 connecting to the upper frustoconical side section 12g.

A lower frustoconical side section 12d extends from the cylindrical neck 8.

A lower ellipsoidal section 12e connects to the lower frustoconical side section 12d.

An ellipsoid keel 12f is formed at the bottom of the lower ellipsoidal section 12e.

- 10 A fin-shaped appendage 84 is secured to a lower and an outer portion of the exterior of the ellipsoid keel 12f.

Figure 12 is detailed view of the buoyant structure with a cylindrical neck.

The buoyant structure 10 is shown with the cylindrical neck 8.

- 15 A fin-shaped appendage 84 is shown secured to a lower and an outer portion of the exterior of the ellipsoid keel and extends from the ellipsoid keel into the water.

Figure 13 is a cut away view of the buoyant structure with a cylindrical neck in a transport configuration.

The buoyant structure 10 is shown with the cylindrical neck 8.

- 20 In embodiments, the buoyant structure 10 can have a pendulum 116, which can be moveable. In embodiments, the pendulum is optional and can be partly incorporated into the hull to provide optional adjustments to the overall hull performance.

In this Figure, the pendulum 116 is shown at a transport depth.

In embodiments, the moveable pendulum can be configured to move between a transport depth and an operational depth and the pendulum can be configured to dampen

movement of the watercraft as the watercraft moves from side to side in the water.

Figure 14 is a cut away view of the buoyant structure 10 with a cylindrical neck 8 in an operational configuration.

In this Figure, the pendulum 116 is shown at an operational depth extending from the  
5 buoyant structure 10.

While these embodiments have been described with emphasis on the embodiments, it should be understood that within the scope of the appended claims, the embodiments might be practiced other than as specifically described herein.

**CLAIMS**

What is claimed is:

1. A buoyant structure comprising: a hull having a main deck, an upper cylindrical side section, an upper frustoconical side section, a cylindrical neck, a lower frustoconical side section that extends from the cylindrical neck, a lower ellipsoidal section, an ellipsoid keel, and a fin-shaped appendage secured to a lower and an outer portion of the exterior of the ellipsoid keel.  
5
2. The buoyant structure of claim 1, wherein a pendulum is positioned to move between a transport depth and an operational depth, and wherein the pendulum is configured to dampen movement of a watercraft as the watercraft moves from side to side in water.  
10
3. The buoyant structure of claim 1, wherein the main deck has a superstructure comprising at least one member selected from the group consisting of: crew accommodations, a heliport, a crane, a control tower, a dynamic position system in the control tower, and an aircraft hangar.  
15
4. The buoyant structure of claim 1, wherein the hull has a berthing facility and catenary mooring lines for mooring the buoyant structure to a seafloor.
5. The buoyant structure of claim 1, further comprising a gangway for traversing between the buoyant structure and a watercraft.
- 20 6. The buoyant structure of claim 1, comprising the hull with a center of gravity below a center of buoyancy to provide an inherent stability to the buoyant structure.
7. The buoyant structure of claim 1, wherein the upper frustoconical side section engages the cylindrical neck, wherein the buoyant structure comprises:  
25
  - a. the upper cylindrical side section extending downwardly from the main deck; and
  - b. the upper frustoconical side section located below the upper cylindrical

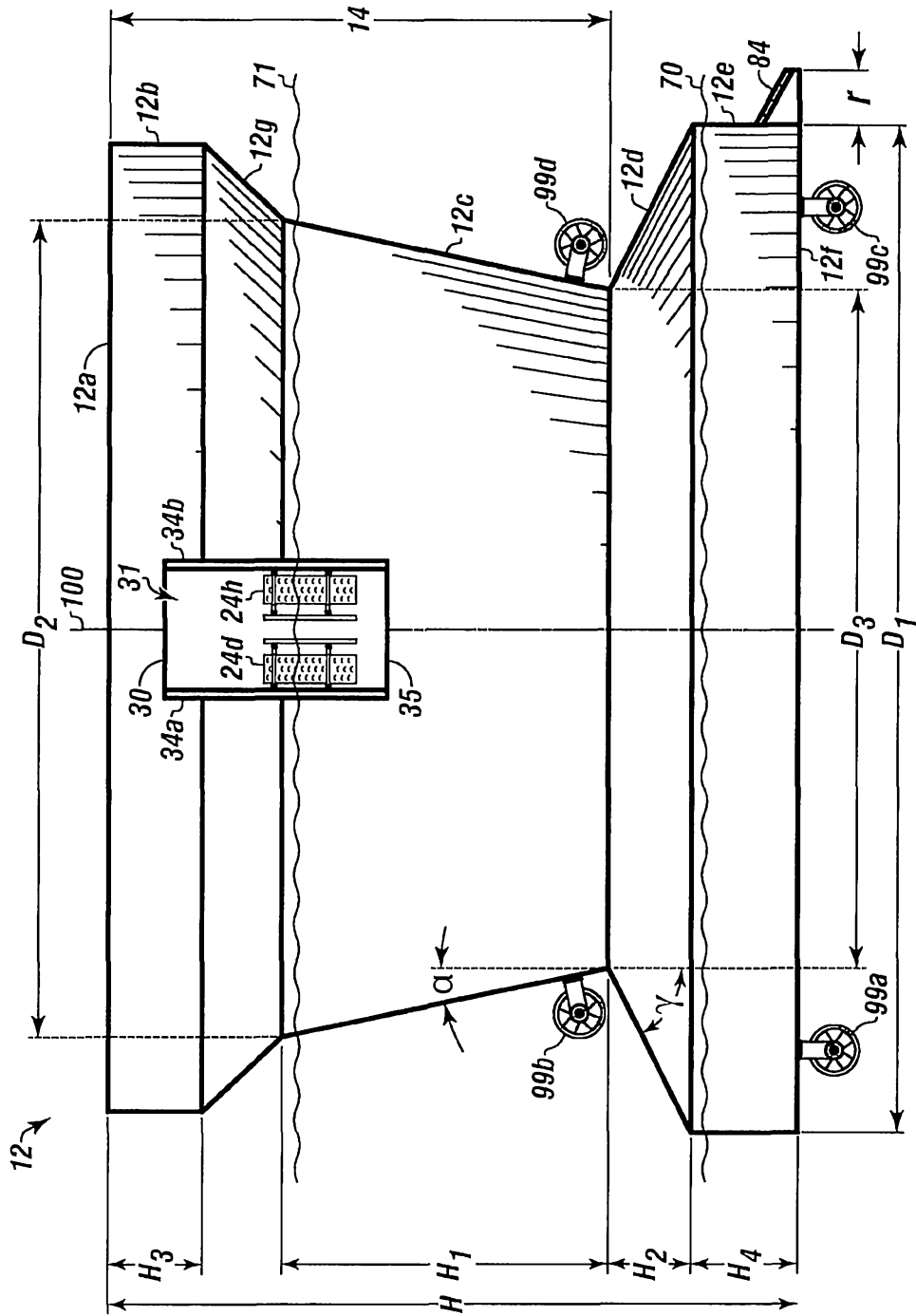
side section and maintained to be above a water line for a transport depth and partially below a water line for an operational depth of the buoyant structure; and

5 wherein the upper frustoconical side section has a gradually reducing diameter from a diameter of the upper cylindrical side section.



02/11

FIGURE 2



03/11

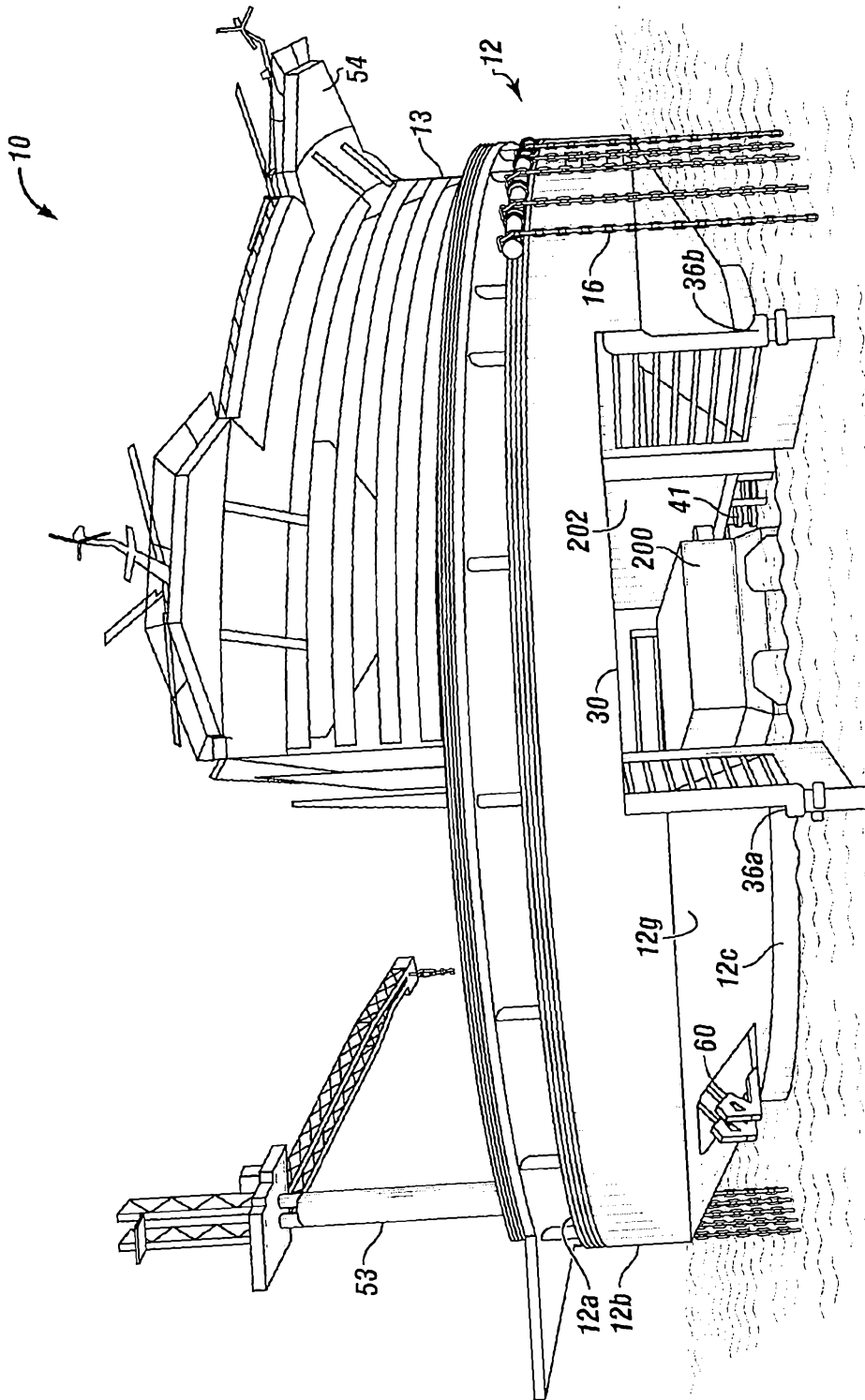
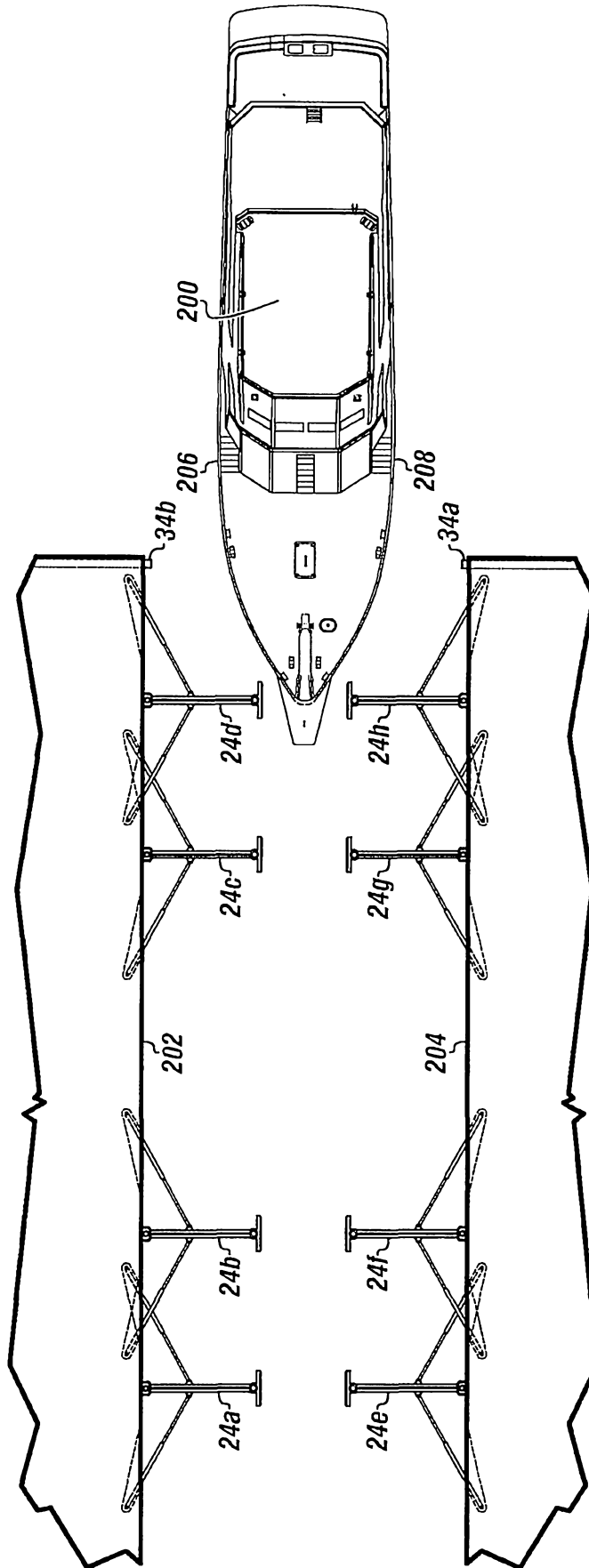


FIGURE 3

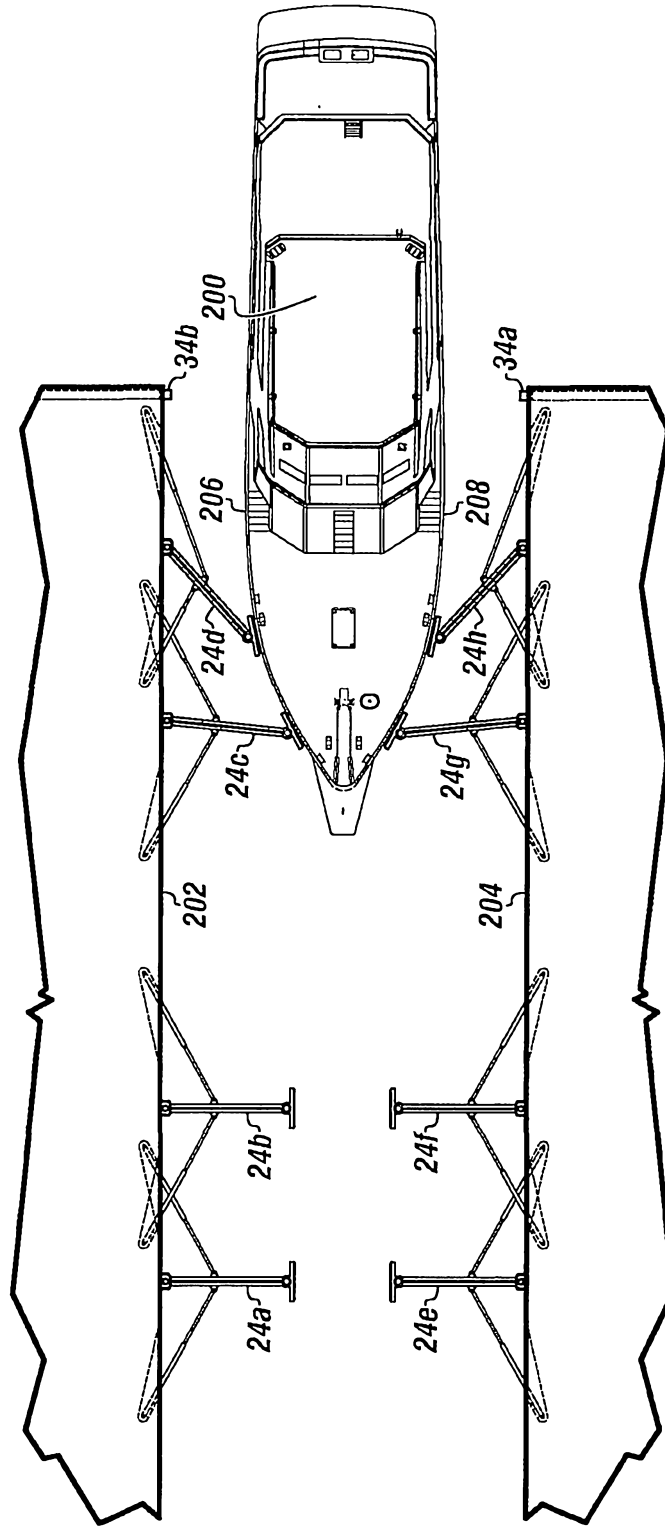
04/11

FIGURE 4A



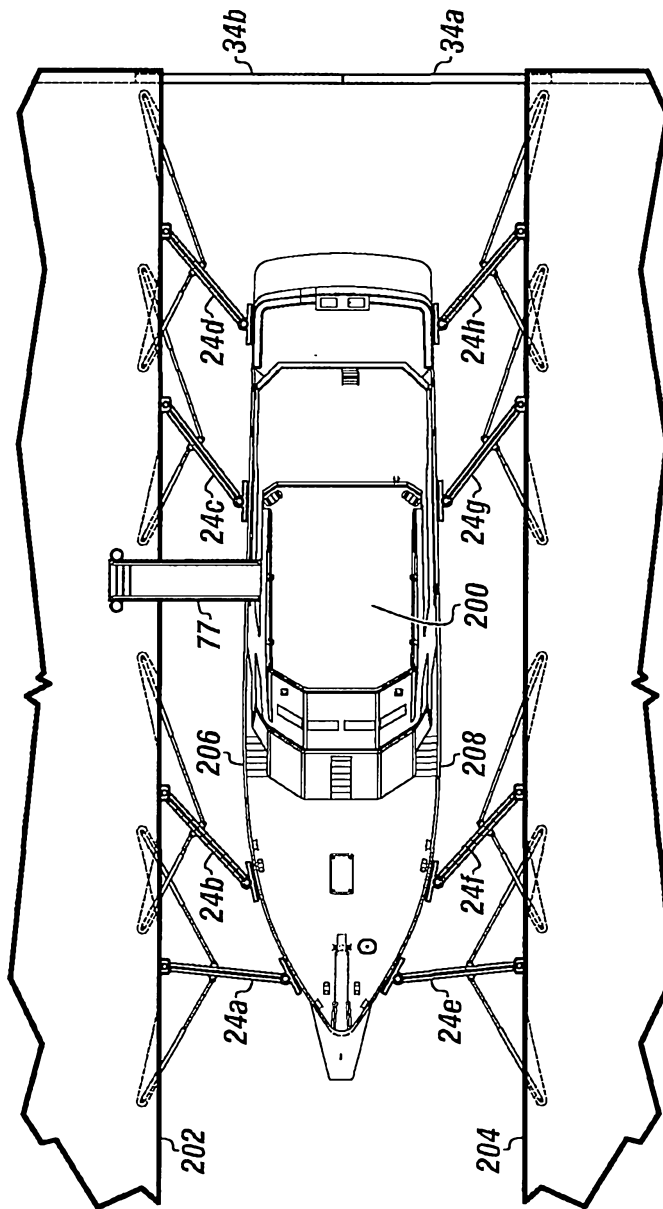
05/11

FIGURE 4B



06/11

FIGURE 4C



07/11

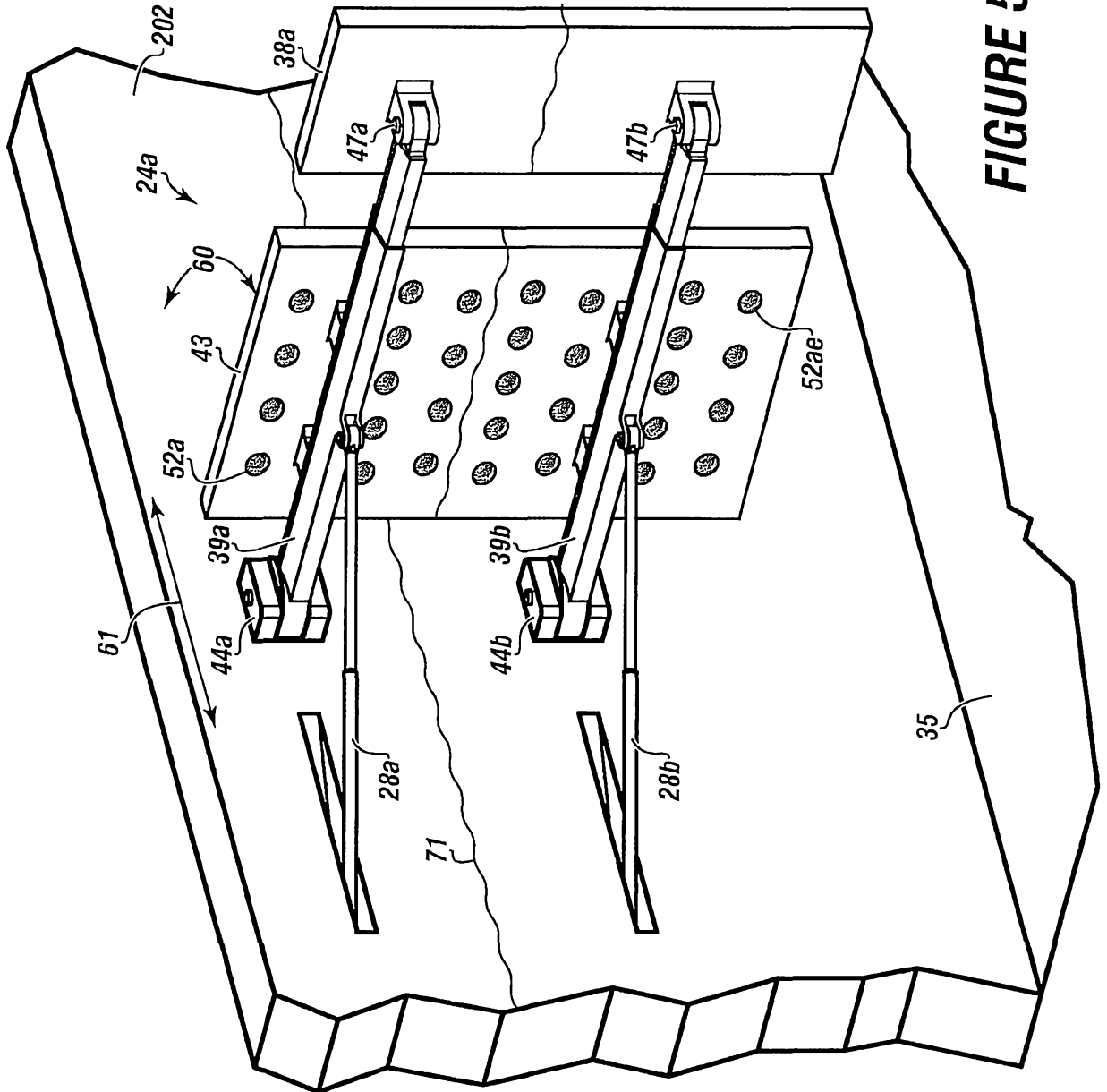


FIGURE 5

08/11

FIGURE 7

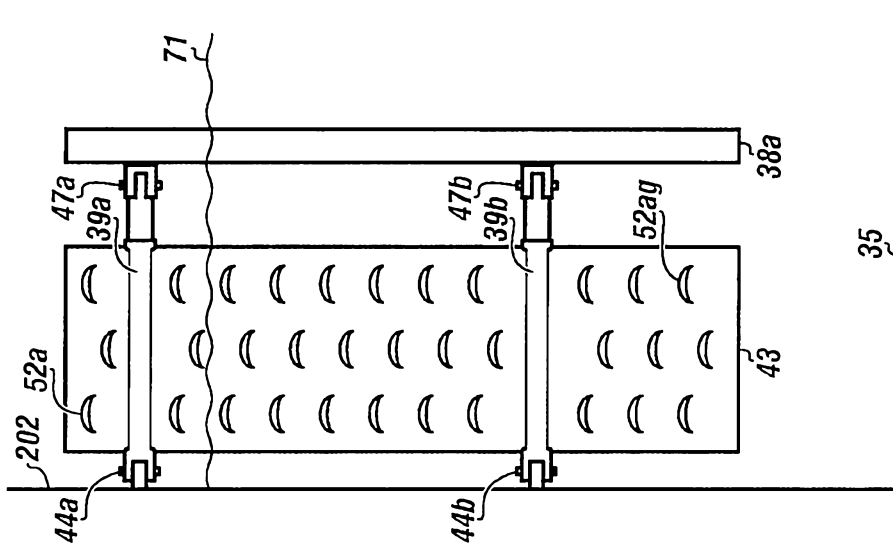


FIGURE 6

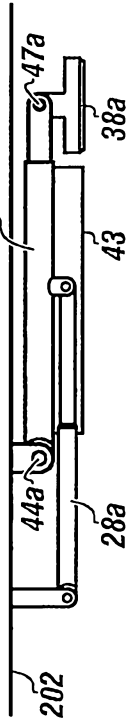
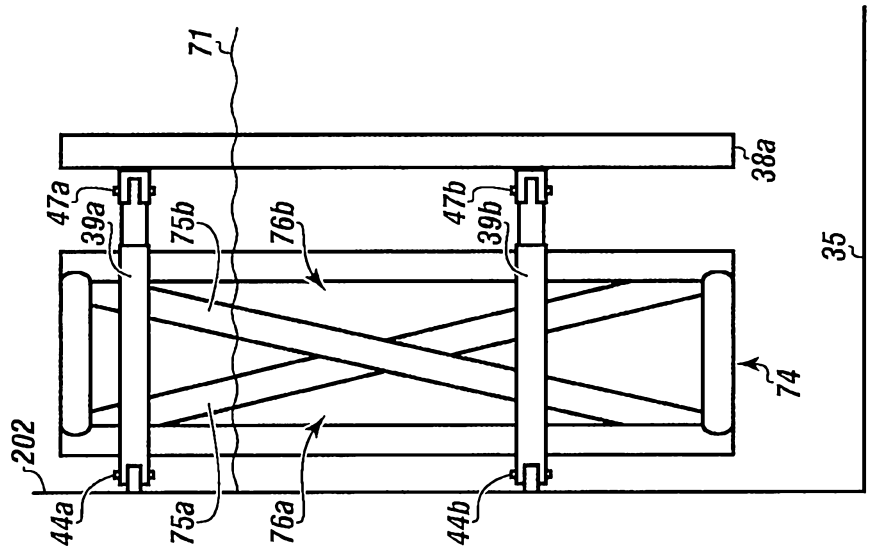


FIGURE 8



09/11

FIGURE 9

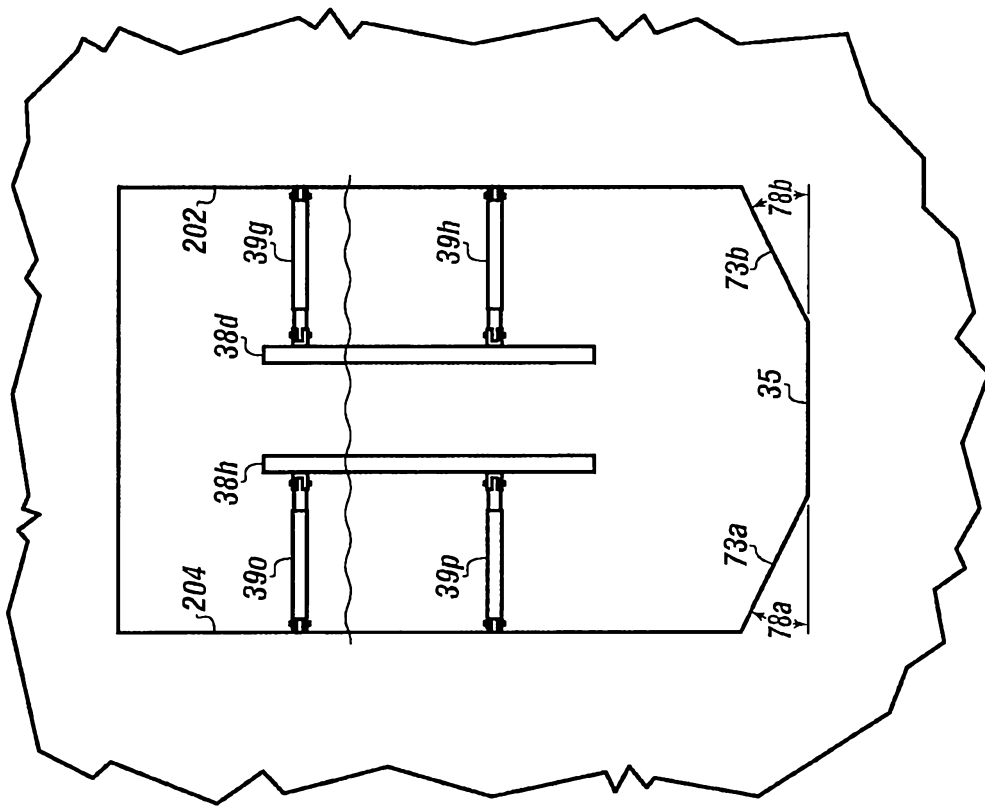


FIGURE 10

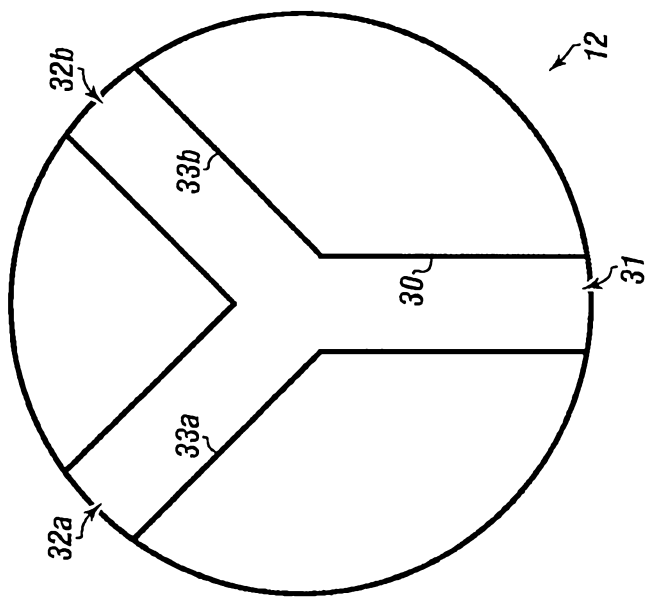
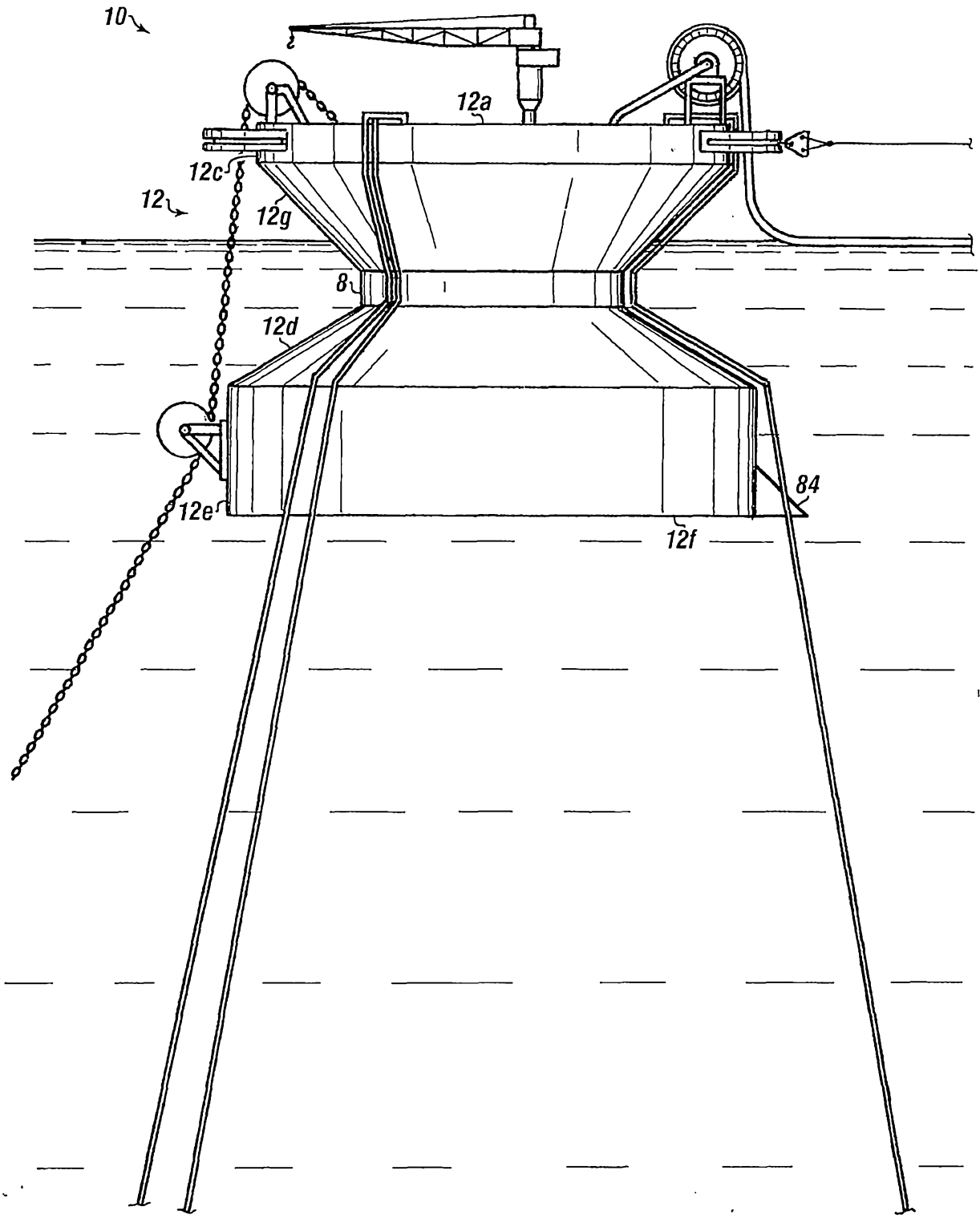
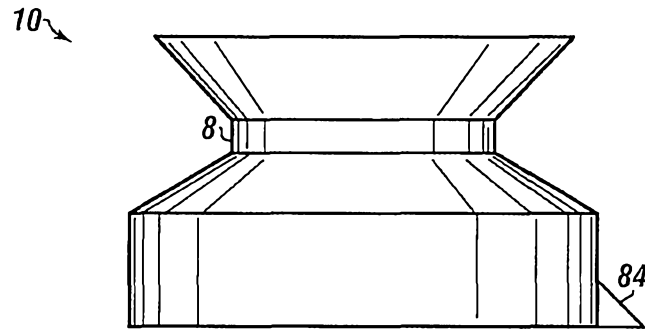


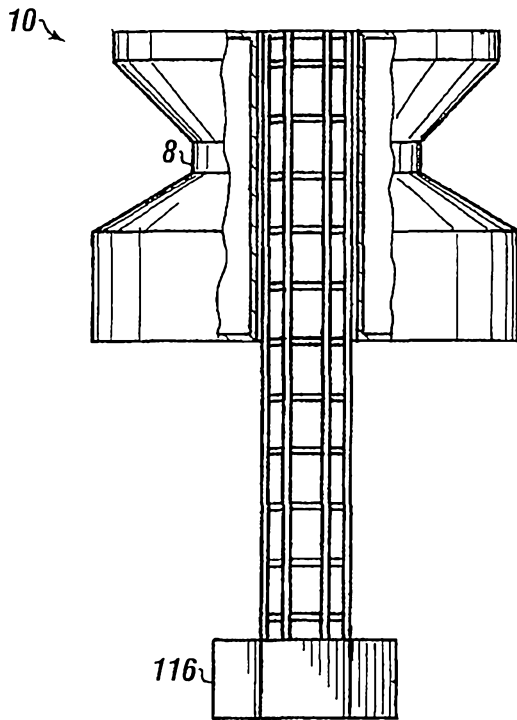
FIGURE 11



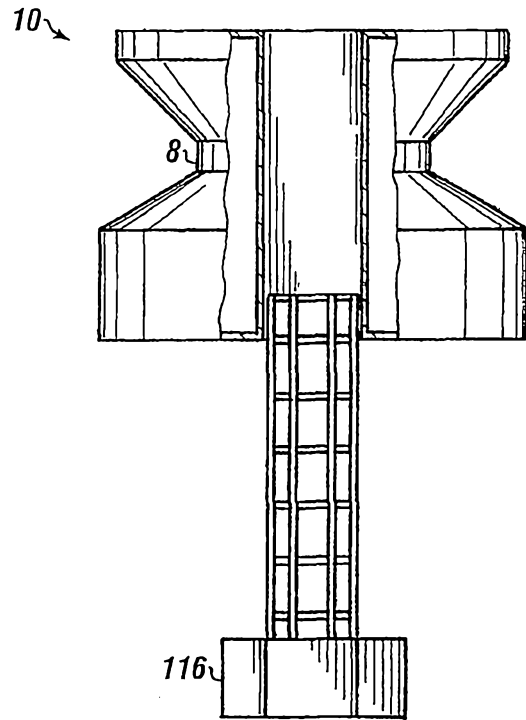


**FIGURE 12**

**FIGURE 13**



**FIGURE 14**



**ABSTRACT**

A buoyant structure having a hull, a main deck, an upper cylindrical side section extending downwardly from the main deck, an upper frustoconical side section, a cylindrical neck, a lower ellipsoidal section that extends from the cylindrical neck, an  
5 ellipsoidal keel and a fin-shaped appendage secured to a lower and an outer portion of the exterior of the ellipsoid keel. The upper frustoconical side section located below the upper cylindrical side section and maintained to be above a water line for a transport depth and partially below the water line for an operational depth of the buoyant structure.

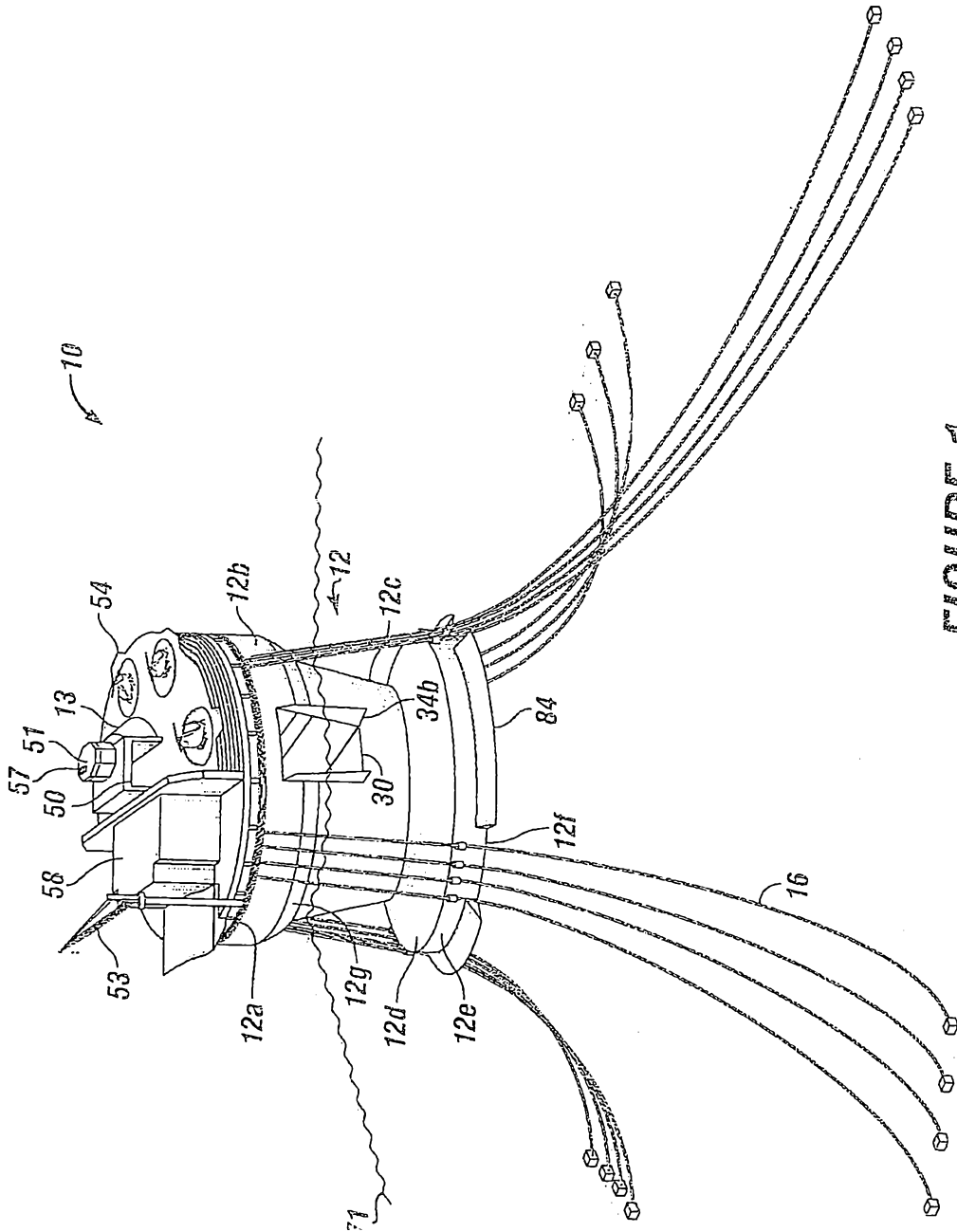


FIGURE 1