

(No Model.)

2 Sheets—Sheet 1.

H. L. WILSON.
STEAM BOILER.

No. 526,600.

Patented Sept. 25, 1894.

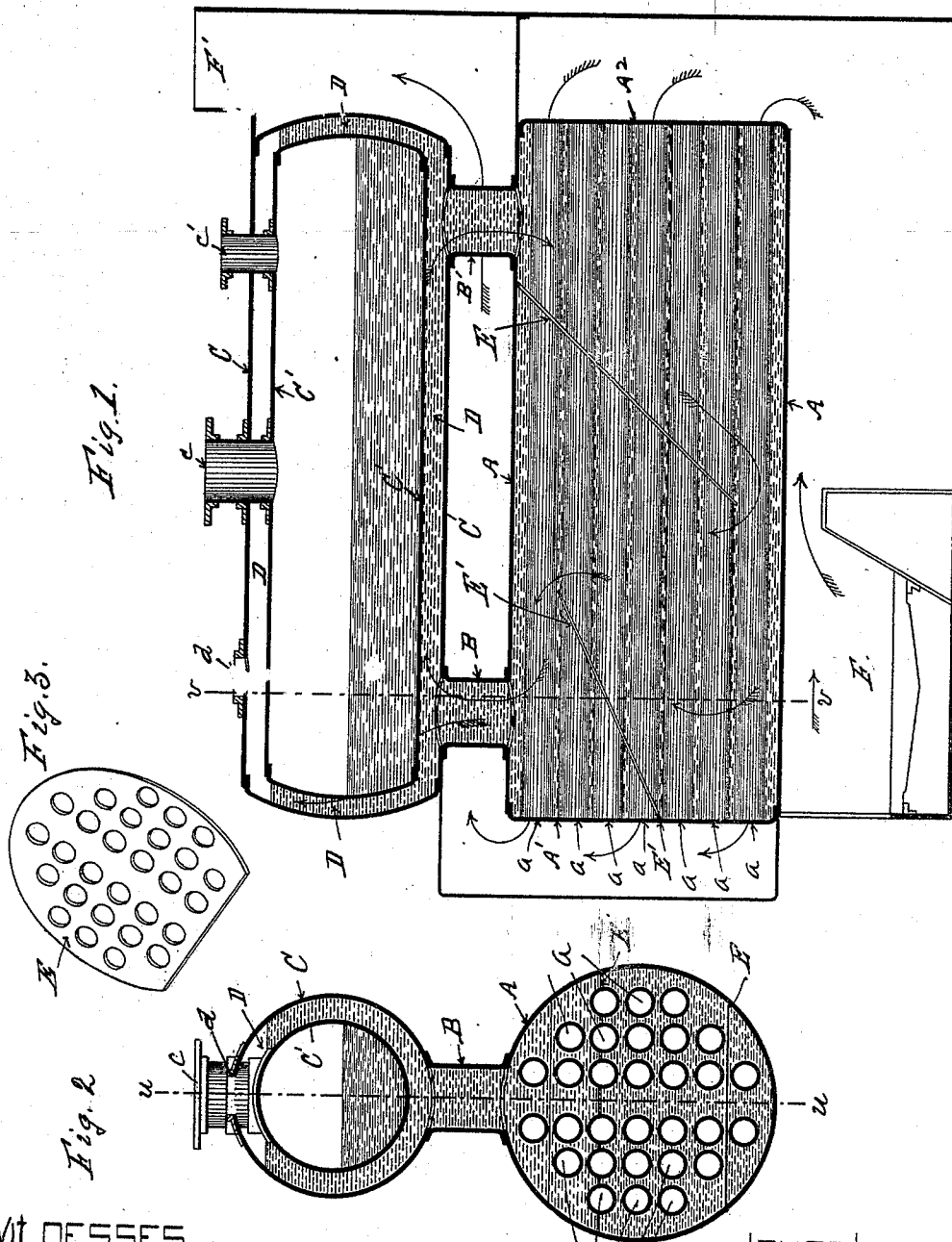

WITNESSES.

F. Einfeldt
F. J. Barutz

INVENTOR.

Harry I. Wilson
By A. Sturgis
Atty.

(No Model.)

2 Sheets—Sheet 2.

H. L. WILSON.
STEAM BOILER.

No. 526,600.

Patented Sept. 25, 1894.

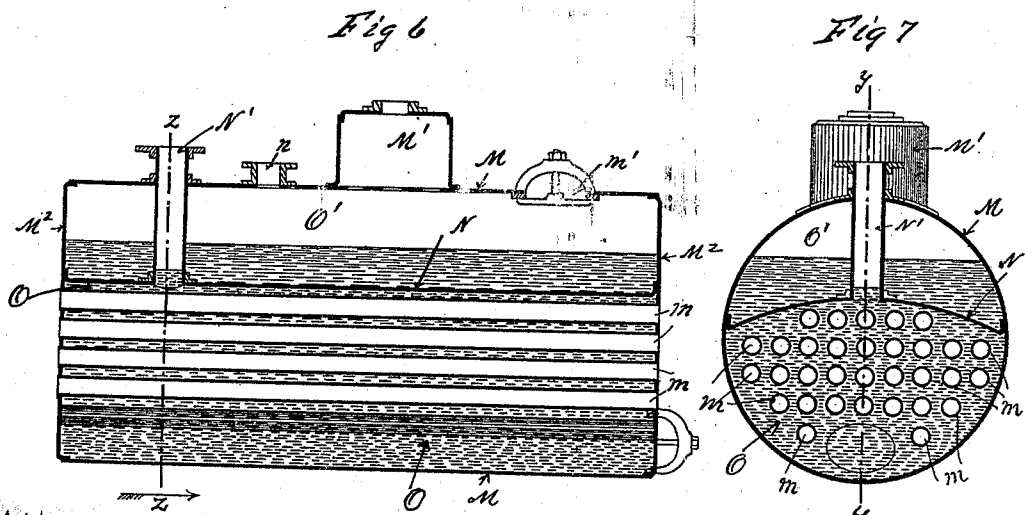
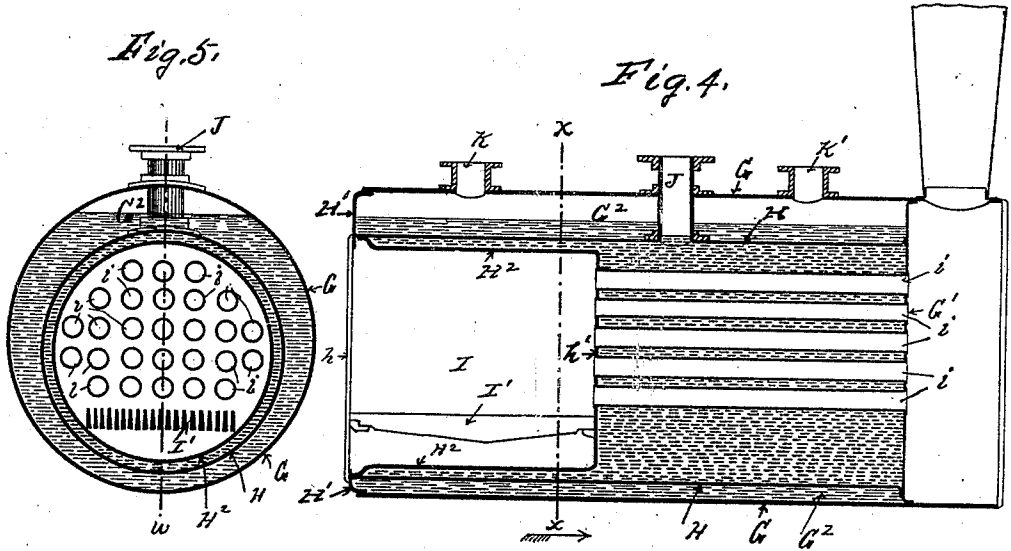

WITNESSES.
F. Einfeldt
F. J. Bauer

INVENTOR.
Edw. I. Wilson
 By *H. Sturgeon*
 atty.

UNITED STATES PATENT OFFICE.

HARRY L. WILSON, OF ERIE, PENNSYLVANIA.

STEAM-BOILER.

SPECIFICATION forming part of Letters Patent No. 526,600, dated September 25, 1894.

Application filed March 12, 1894. Serial No. 503,348. (No model.)

To all whom it may concern:

Be it known that I, HARRY L. WILSON, a citizen of the United States, residing at the city of Erie, in the county of Erie and State of Pennsylvania, have invented certain new and useful Improvements in Steam-Boilers; and I do hereby declare the following to be a full, clear, and exact description of the invention, such as will enable others skilled in the art to which it appertains to make and use the same, reference being had to the accompanying drawings, and to the letters of reference marked thereon, forming part of this specification.

My invention consists in the improvements in steam boilers, hereinafter set forth and explained, and illustrated in the accompanying drawings.

In steam boilers, as ordinarily constructed, the fire is in direct contact with the shell and tubes inclosing the water to be evaporated, and there are more or less impurities in the water ordinarily used in such boilers, which are separated therefrom by the heat and left as residuum, which settles upon the tubes and bottom of the boiler, and the intense heat from the fire operating directly thereon, bakes the same upon the tubes and shell of the boiler, so as to produce a scale of greater or less thickness thereon, by means whereof the heat conducting power of the tubes and shell of the boiler is diminished in proportion to the thickness of the scale so formed, making it necessary to frequently blow off and clean the boiler in order to maintain its efficiency.

By practical experiments I have discovered that if two bodies of water or other fluids which are good absorbents and conductors of heat, are enclosed in a boiler, separated from each other by a metallic shell or diaphragm, and heat applied to one of such bodies of fluid, it will be communicated to the other to such an extent that the heat of both of such bodies of fluid will be practically the same, and the pressure developed by such heat substantially equal in both of the compartments of the boiler. In utilizing this discovery, I construct my improved steam boiler with two compartments wholly separated from each other by means of a shell or diaphragm. One of these compartments is in direct contact with

the fire, and the other is not, as hereinafter more fully described. The compartment with which the fire contacts I fill preferably with distilled water or other fluid, substantially free from any substances liable to be separated therefrom by heat and settle upon the tubes and shell of the boiler, and to the other compartment I supply the water from which the steam is to be generated for use, in the usual manner.

Other features of my invention will appear hereinafter in the specification and claims, and in the accompanying drawings, in which—

Figure 1. is a vertical longitudinal section, on the line *u, u*, in Fig. 2, of one construction of my improved steam boiler. Fig. 2. is a vertical transverse section of the same, on the line *v, v*, in Fig. 1, looking in the direction of the arrow. Fig. 3. is a perspective view of one of the baffle plates used in the same. Fig. 4. is a vertical longitudinal section, on the line *w, w*, in Fig. 5, of a modified construction of my improved steam boiler. Fig. 5. is a vertical transverse section of the same, on the line *x, x*, in Fig. 4, looking in the direction of the arrow. Fig. 6. is a vertical longitudinal section, on the line *y, y*, in Fig. 7, of another modified construction of my improved steam boiler. Fig. 7. is a vertical transverse section of the same, on the line *z, z*, in Fig. 6, looking in the direction of the arrow.

In the construction of my improved steam boiler, shown in Figs. 1 and 2, A is a cylindrical boiler shell provided with heads A' and A² and tubes *a* secured therein in the usual manner, except that the tubes *a* are distributed uniformly throughout the heads A' and A², instead of leaving the upper portions thereof free from tubes as is ordinarily done. Near the ends of the top of the shell A are upwardly projecting hollow legs B and B', to the upper ends of which a shell C is secured, and within the shell C is secured a second shell C', leaving a space D between the two shells C and C', to which are secured a steam outlet *c* and a safety valve and steam gage connection *c'*, both of which pass up out through the outside shell C. The shell C is also provided with a safety valve and steam gage connection *d* which communicates with

the space D which connects through hollow legs B and B' with the inside of the shell A.

In the shell A, I preferably place two diaphragms or baffle plates E and E', one of which E is illustrated in perspective in Fig. 3, the plate E being placed over the tubes *a* and extending from the top of the shell just in front of the leg B' downward at an angle toward the front end of the shell nearly to the bottom thereof, while the plate E' commencing at the front head A' nearly half way up from the bottom of the shell A, extends rearwardly and upwardly at an angle, preferably to the lower sides of the topmost row of flues *a*, these baffle plates operating to divert the circulation of water in the shell A, as illustrated by the arrows in Fig. 1. The shell A is mounted in setting provided with a fire-box F under the front end of the shell A, from which the heat passes along under the shell and from thence back through the flues *a* to the front end of the shell A, and thence up over the top thereof under the shell C and out through the smoke stack F'. In operation, I fill the shell C and the space D between the shells C and C' preferably with distilled water, leaving sufficient room in the top of the space D to provide for the expansion thereof when heated, as illustrated in Figs. 1 and 2. I then fill the space inside of the shell C' to the proper height, with the water it is desired to generate steam from, when fire is then applied to the boiler as hereinbefore described. It will be seen that it only contacts with those portions of the boiler which are filled with the distilled water, which in turn communicates its heat to the water within the shell C' and thereby resolving the same into steam, to be drawn off and used as desired.

In the modified construction of my improved steam boiler, shown in Figs. 4 and 5, G is the outer shell and G' the rear head thereof. Inside of the shell G, I secure a second shell H, the rear end of which is secured to the head G' and the front ends of the shells G and H are secured together by a ring H', so as to leave an annular space G² between the shells G and H, and also leaving an opening *h* the full size of the inner shell H', and within the front end of the shell H is secured a third shell H² which extends rearwardly far enough to form the fire-box I of the boiler, where it is provided with a head *h'*. In the lower part of the fire-box I are grate bars I' supported in the usual manner. Between the heads *h'* and G' are tubes *i* distributed uniformly over the entire head *h'* above the grate bars I'.

To the top of the shell H is secured an upwardly projecting pipe J which is also secured in the outer shell G, to which pipe an ordinary safety valve and steam gage can be attached, and to the top of the shell G is secured an outlet opening K for a steam pipe, and also a safety valve and steam gage opening K' which openings K and K' communicate with the annular space G² between the

shells G and H. Secured to the rear of the shell G is a breeching L communicating with a smoke stack L'.

In operation the inner shell H is entirely filled preferably with distilled water, while the annular space G² is filled to the proper height with the water to be used for generating steam, and when fire is applied thereto it contacts only with that portion of the boiler inclosing the distilled water, which as it is heated gives off its heat to the water in the annular space G² inclosed between the shells G and H, producing steam therefrom.

In the modified construction of my improved steam boiler, shown in Figs. 6 and 7, the construction of the outer shell M, the steam dome M', the heads M² and the arrangement of the tubes *m* therein are of the usual construction used in ordinary tubular boilers, but just above the upper row of tubes *m*, I secure a curved diaphragm N firmly riveted to the sides of the shell M and heads M² of the shell, so as to form two chambers, a lower one O and an upper one O', and to this diaphragm N, I secure a pipe N' which extends out through and is secured in the top of the shell M, which pipe communicates with the chamber O and to which a safety valve and steam gage may be secured. In the top of the shell M are also a safety valve and steam gage opening *n*, and a convenient hand hole *m'* through which access can be conveniently had to the upper chamber O'. When set as ordinary tubular boilers are usually set, the lower chamber O is filled preferably with distilled water, and the upper chamber O' with the water from which it is desired to generate steam. The fire then contacts only with that portion of the boiler filled with the distilled water, which in turn communicates the heat therein to the water in the upper chamber O' generating steam therefrom as desired.

Having thus fully described my invention, so as to enable others to construct and use the same, what I claim as new, and desire to secure by Letters Patent of the United States, is—

1. The combination in a steam boiler, of a lower section, an upper cylindrical section, an inner shell in said upper section dividing it into an annular outer compartment and an inner cylindrical steam generating compartment, hollow legs connecting the lower section with the annular compartment of the upper section, a steam exit from the steam generating compartment, and safety valve and steam gage outlets from both of said compartments, substantially as and for the purpose set forth.

2. The combination in a steam boiler, of a lower cylindrical section having tubes and inclined baffle plates therein, an upper cylindrical section having an inner shell dividing it into an annular outer compartment, and an inner cylindrical steam generating compartment, hollow legs connecting the lower section with the annular compartment

of the upper section, a steam exit from the steam generating compartment, and safety valve and steam gage outlets from both of said compartments, substantially as and for the purpose set forth.

3. The combination in a multitubular steam boiler, of an inclined diaphragm within the shell of the boiler extending from the central portion of the front boiler head up to the upper row of flues, with a like inclined dia-

phragm within the shell of the boiler extending from the upper portion of the rear of the boiler, downward and forward nearly to the bottom of the boiler, substantially as set forth.

In testimony whereof I affix my signature in presence of two witnesses.

HARRY L. WILSON.

Witnesses:

F. J. BASSETT,
F. EINFELDT.