



US 20070029095A1

(19) **United States**

(12) **Patent Application Publication**
Brisco et al.

(10) **Pub. No.: US 2007/0029095 A1**

(43) **Pub. Date: Feb. 8, 2007**

(54) **APPARATUS AND METHOD FOR RUNNING
A RADIALY EXPANDABLE TUBULAR
MEMBER**

(86) PCT No.: **PCT/US04/08073**

§ 371(c)(1),
(2), (4) Date: **Apr. 27, 2006**

(75) Inventors: **David Paul Brisco**, Duncan, OK (US);
Michael Dennis Bullock, Houston, TX
(US); **Kevin K. Waddell**, Houston, TX
(US)

Related U.S. Application Data

(60) Provisional application No. 60/455,718, filed on Mar.
18, 2003.

Correspondence Address:
HAYNES AND BOONE, LLP
901 MAIN STREET
SUITE 3100
DALLAS, TX 75202-3789 (US)

Publication Classification

(51) **Int. Cl.**
E21B 23/02 (2006.01)
(52) **U.S. Cl.** **166/380; 166/207**

(73) Assignee: **Enventure Global Technology**, Hous-
ton, TX (US)

(57) **ABSTRACT**

A tubular apparatus and method, according to which a first tubular member is adapted to be lowered into a well bore and a second tubular member is connected to the first tubular member. A third tubular member is normally connected to the first tubular member and disconnected from the second tubular member, and is adapted for movement relative to the first and second tubular members to disconnect from the first tubular member and connect to the second tubular member.

(21) Appl. No.: **10/549,410**

(22) PCT Filed: **Mar. 18, 2004**

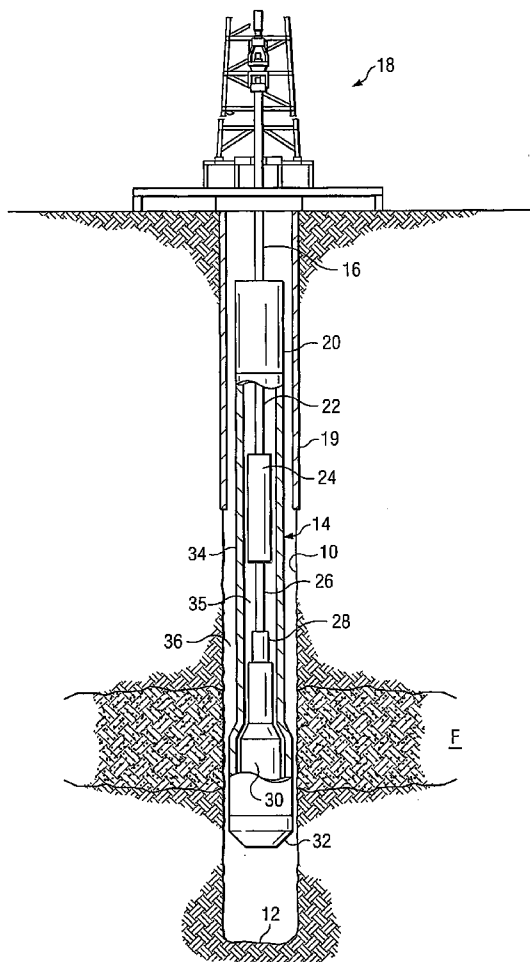

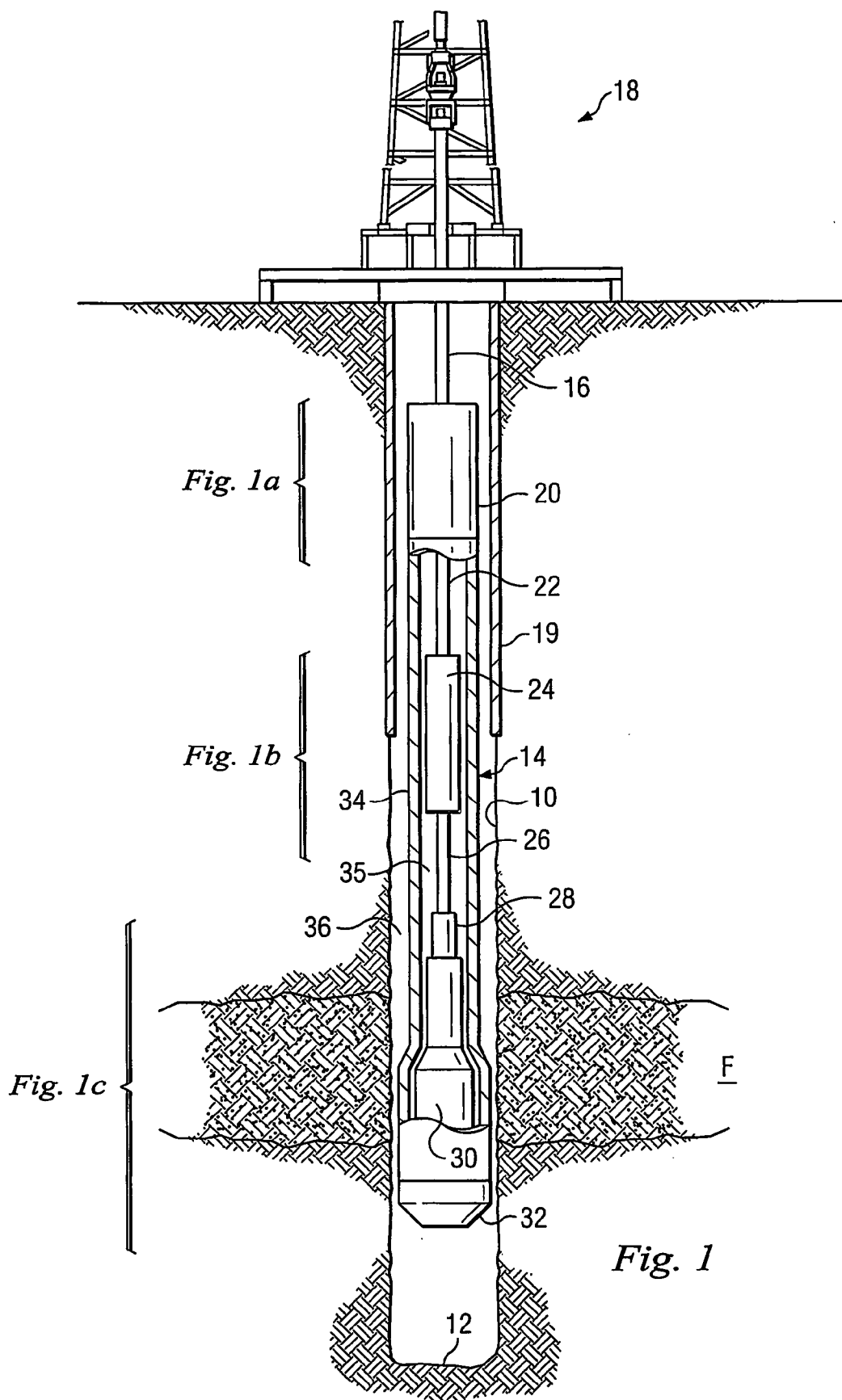

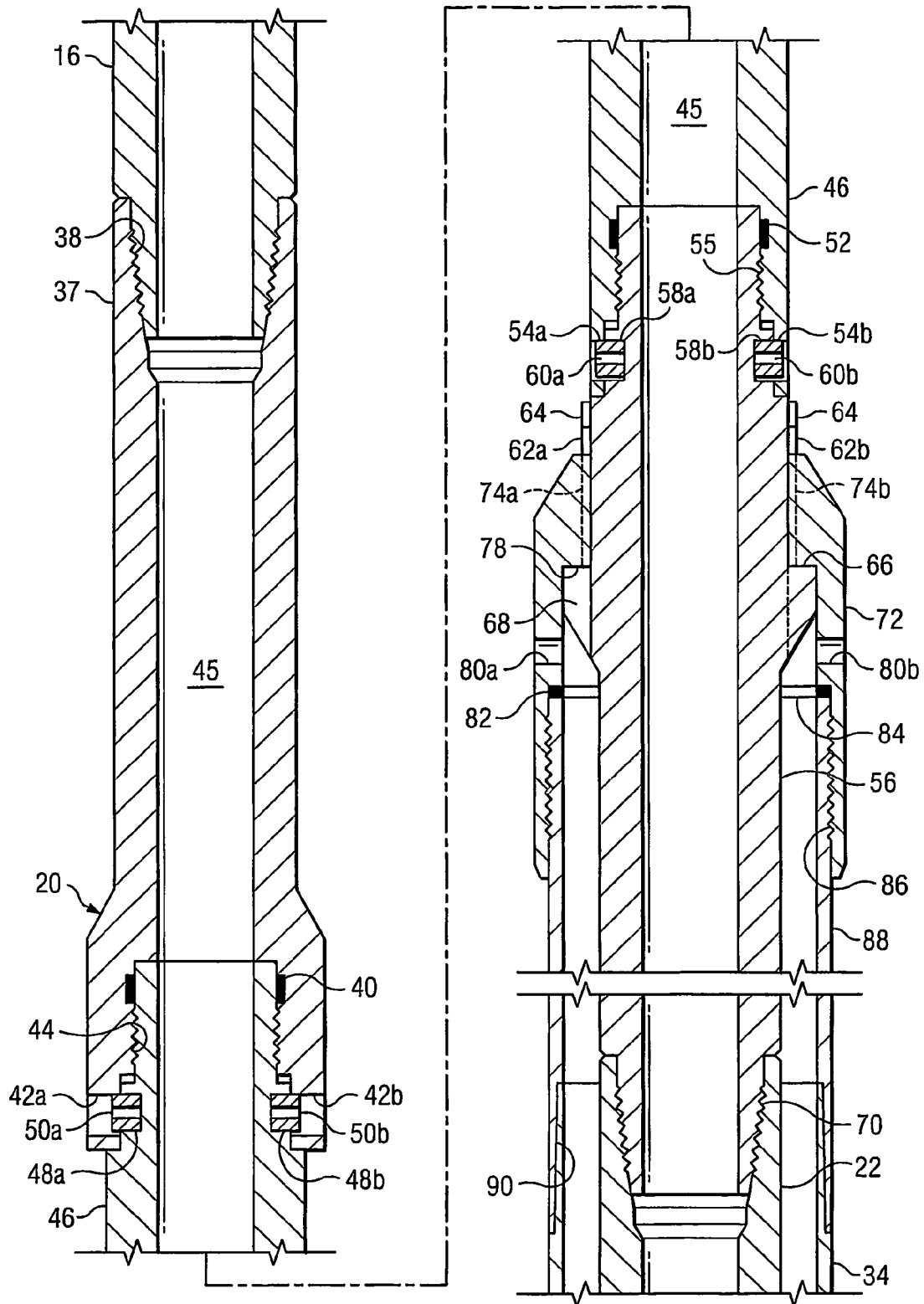

Fig. 1a

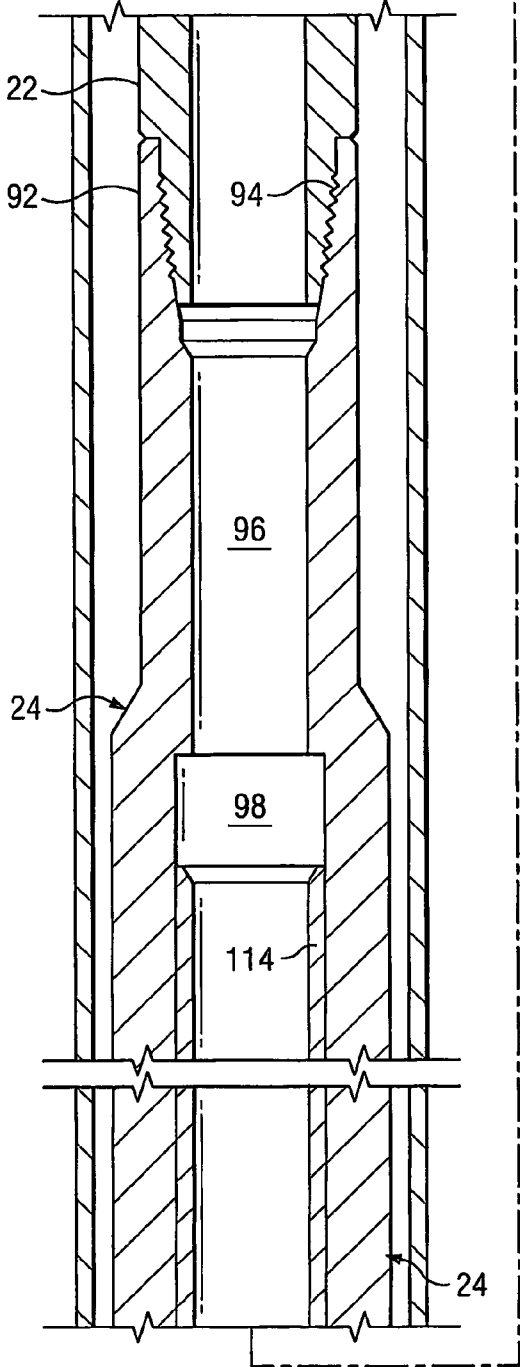
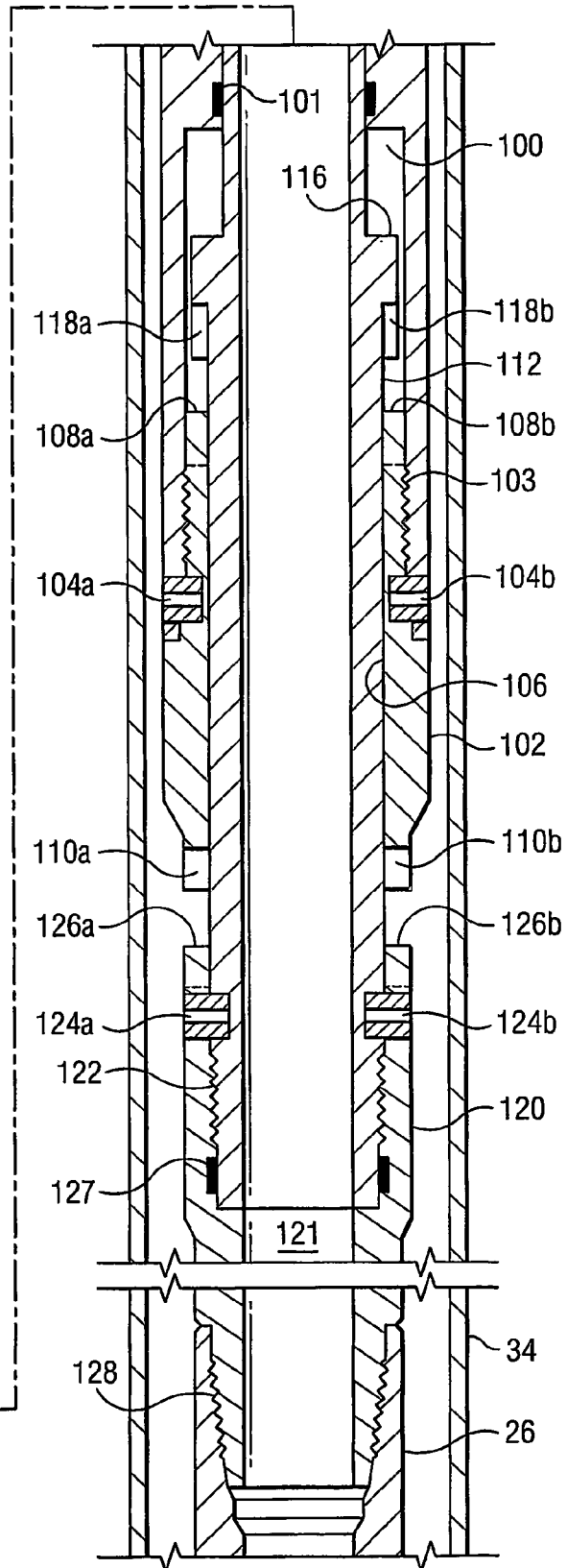

Fig. 1b



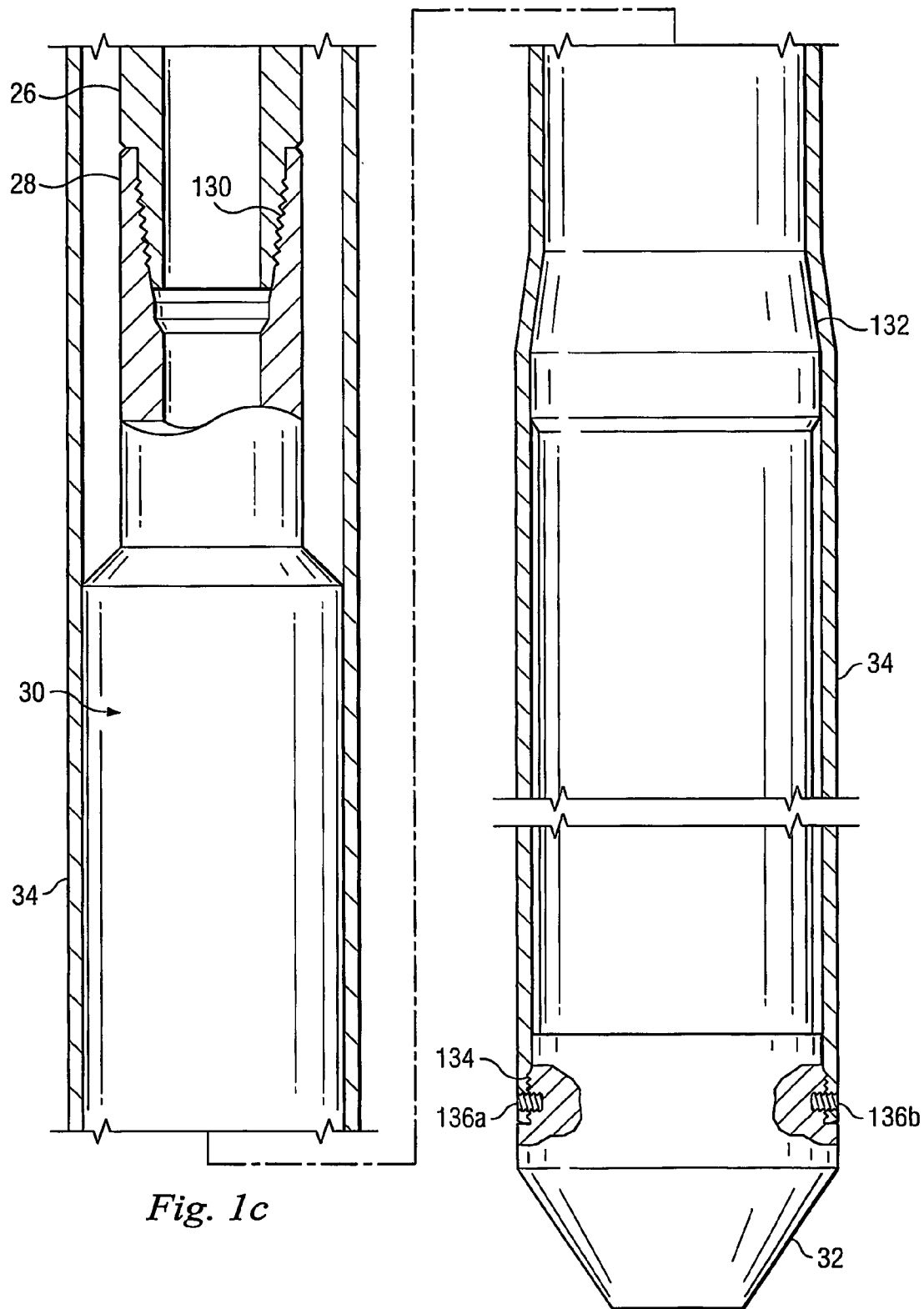

Fig. 1c

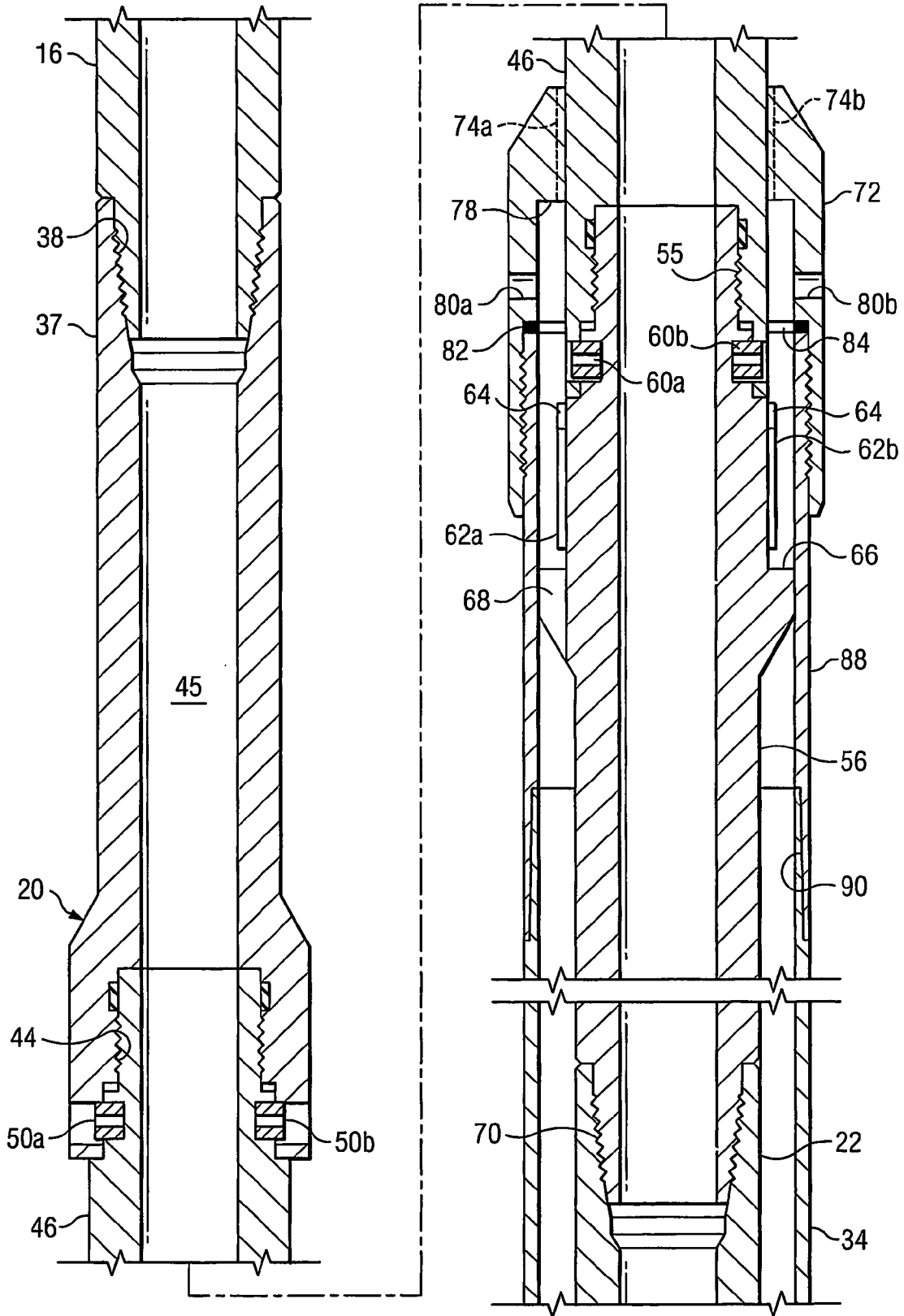

Fig. 2a

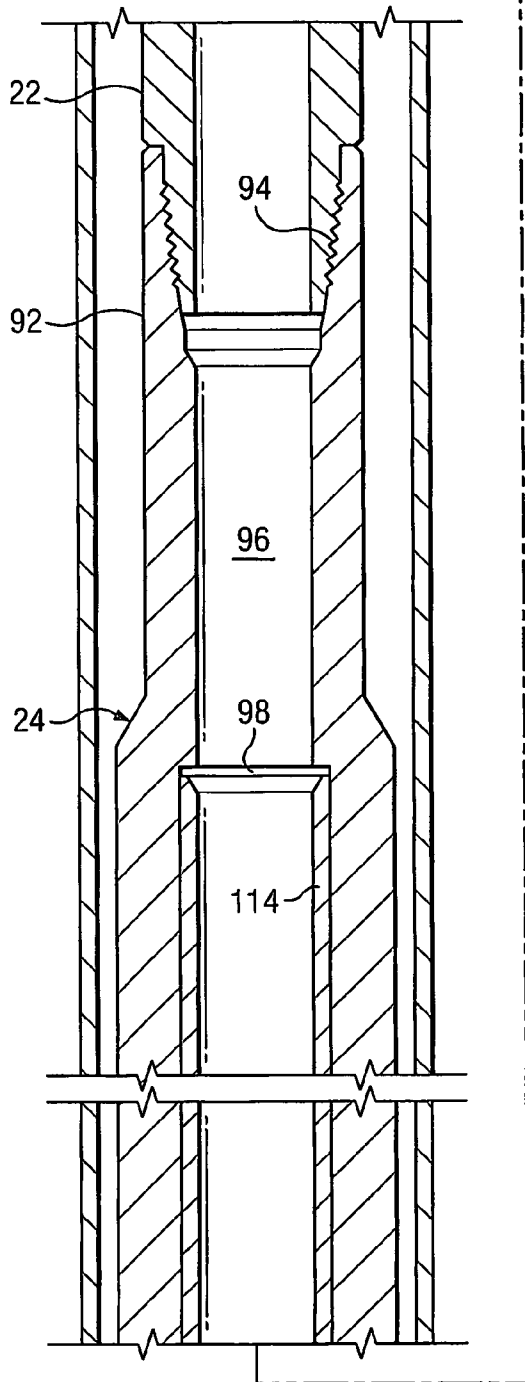
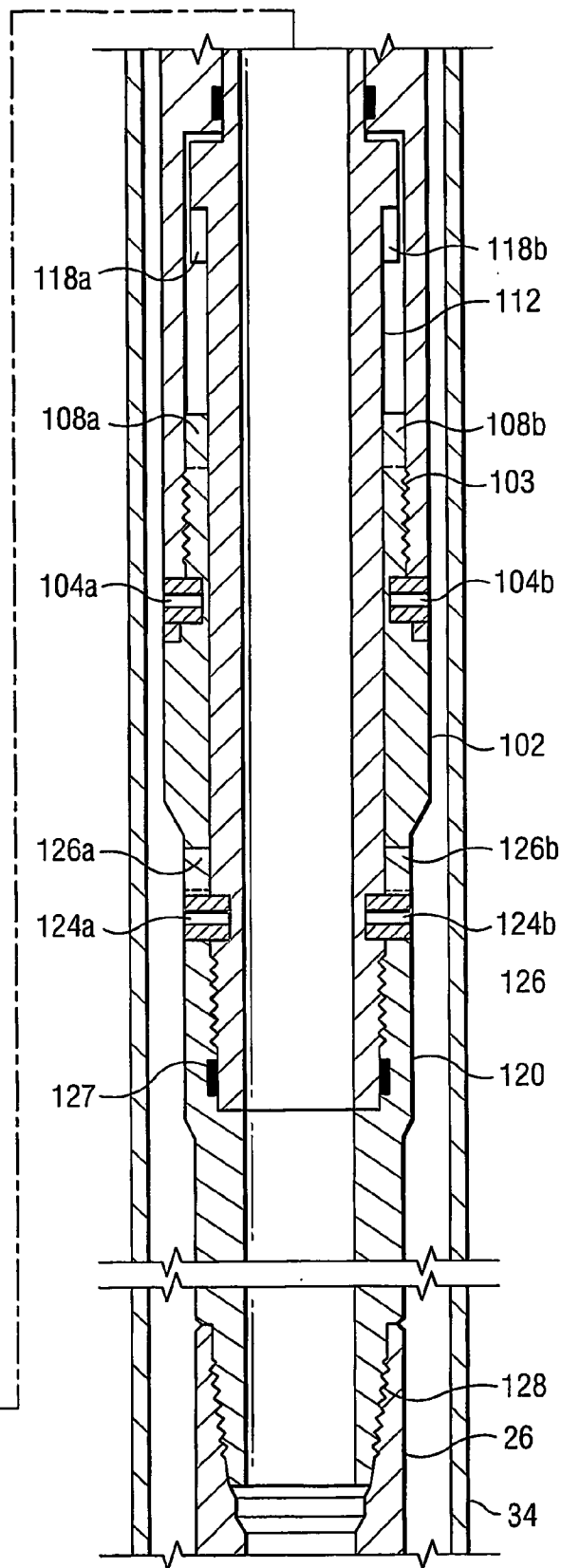

Fig. 2b



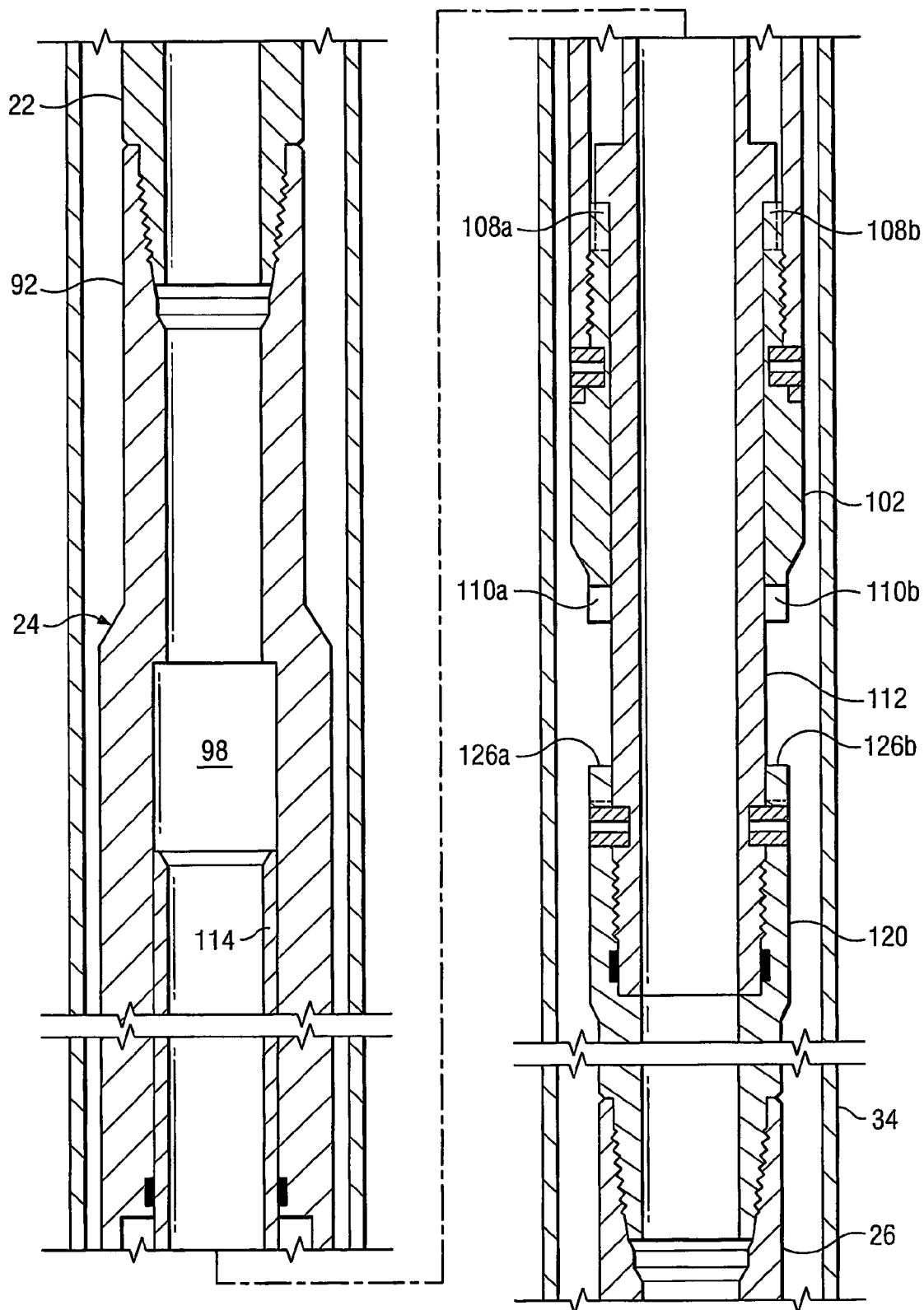

Fig. 3b

**APPARATUS AND METHOD FOR RUNNING A
RADIALLY EXPANDABLE TUBULAR MEMBER****CROSS REFERENCE TO RELATED
APPLICATIONS**

[0001] The present application claims the benefit of the filing date of U.S. provisional patent application Ser. No. 60/455,718, attorney docket no. 25791.262, filed on Mar. 18, 2003, the disclosure of which is incorporated herein by reference.

[0002] This application is related to the following co-pending applications: (1) U.S. Pat. No. 6,497,289, which was filed as U.S. patent application Ser. No. 09/454,139, attorney docket no. 25791.03.02, filed on Dec. 3, 1999, which claims priority from provisional application 60/111,293, filed on Dec. 7, 1998, (2) U.S. patent application Ser. No. 09/510,913, attorney docket no. 25791.7.02, filed on Feb. 23, 2000, which claims priority from provisional application 60/121,702, filed on Feb. 25, 1999, (3) U.S. patent application Ser. No. 09/502,350, attorney docket no. 25791.8.02, filed on Feb. 10, 2000, which claims priority from provisional application 60/119,611, filed on Feb. 11, 1999, (4) U.S. Pat. No. 6,328,113, which was filed as U.S. patent application Ser. No. 09/440,338, attorney docket number 25791.9.02, filed on Nov. 15, 1999, which claims priority from provisional application 60/108,558, filed on Nov. 16, 1998, (5) U.S. patent application Ser. No. 10/169,434, attorney docket no. 25791.10.04, filed on Jul. 1, 2002, which claims priority from provisional application 60/183,546, filed on Feb. 18, 2000, (6) U.S. patent application Ser. No. 09/523,468, attorney docket no. 25791.11.02, filed on Mar. 10, 2000, which claims priority from provisional application 60/124,042, filed on Mar. 11, 1999, (7) U.S. Pat. No. 6,568,471, which was filed as patent application Ser. No. 09/512,895, attorney docket no. 25791.12.02, filed on Feb. 24, 2000, which claims priority from provisional application 60/121,841, filed on Feb. 26, 1999, (8) U.S. Pat. No. 6,575,240, which was filed as patent application Ser. No. 09/511,941, attorney docket no. 25791.16.02, filed on Feb. 24, 2000, which claims priority from provisional application 60/121,907, filed on Feb. 26, 1999, (9) U.S. Pat. No. 6,557,640, which was filed as patent application Ser. No. 09/588,946, attorney docket no. 25791.17.02, filed on Jun. 7, 2000, which claims priority from provisional application 60/137,998, filed on Jun. 7, 1999, (10) U.S. patent application Ser. No. 09/981,916, attorney docket no. 25791.18, filed on Oct. 18, 2001 as a continuation-in-part application of U.S. Pat. No. 6,328,113, which was filed as U.S. patent application Ser. No. 09/440,338, attorney docket number 25791.9.02, filed on Nov. 15, 1999, which claims priority from provisional application 60/108,558, filed on Nov. 16, 1998, (11) U.S. Pat. No. 6,604,763, which was filed as application Ser. No. 09/559,122, attorney docket no. 25791.23.02, filed on Apr. 26, 2000, which claims priority from provisional application 60/131,106, filed on Apr. 26, 1999, (12) U.S. patent application Ser. No. 10/030,593, attorney docket no. 25791.25.08, filed on Jan. 8, 2002, which claims priority from provisional application 60/146,203, filed on Jul. 29, 1999, (13) U.S. provisional patent application Ser. No. 60/143,039, attorney docket no. 25791.26, filed on Jul. 9, 1999, (14) U.S. patent application Ser. No. 10/111,982, attorney docket no. 25791.27.08, filed on Apr. 30, 2002, which claims priority from provisional patent application Ser. No. 60/162,671, attorney docket no.

25791.27, filed on Nov. 1, 1999, (15) U.S. provisional patent application Ser. No. 60/154,047, attorney docket no. 25791.29, filed on Sep. 16, 1999, (16) U.S. provisional patent application Ser. No. 60/438,828, attorney docket no. 25791.31, filed on Jan. 9, 2003, (17) U.S. Pat. No. 6,564,875, which was filed as application Ser. No. 09/679,907, attorney docket no. 25791.34.02, on Oct. 5, 2000, which claims priority from provisional patent application Ser. No. 60/159,082, attorney docket no. 25791.34, filed on Oct. 12, 1999, (18) U.S. patent application Ser. No. 10/089,419, filed on Mar. 27, 2002, attorney docket no. 25791.36.03, which claims priority from provisional patent application Ser. No. 60/159,039, attorney docket no. 25791.36, filed on Oct. 12, 1999, (19) U.S. patent application Ser. No. 09/679,906, filed on Oct. 5, 2000, attorney docket no. 25791.37.02, which claims priority from provisional patent application Ser. No. 60/159,033, attorney docket no. 25791.37, filed on Oct. 12, 1999, (20) U.S. patent application Ser. No. 10/303,992, filed on Nov. 22, 2002, attorney docket no. 25791.38.07, which claims priority from provisional patent application Ser. No. 60/212,359, attorney docket no. 25791.38, filed on Jun. 19, 2000, (21) U.S. provisional patent application Ser. No. 60/165,228, attorney docket no. 25791.39, filed on Nov. 12, 1999, (22) U.S. provisional patent application Ser. No. 60/455,051, attorney docket no. 25791.40, filed on Mar. 14, 2003, (23) PCT application US02/2477, filed on Jun. 26, 2002, attorney docket no. 25791.44.02, which claims priority from U.S. provisional patent application Ser. No. 60/303,711, attorney docket no. 25791.44, filed on Jul. 6, 2001, (24) U.S. patent application Ser. No. 10/311,412, filed on Dec. 12, 2002, attorney docket no. 25791.45.07, which claims priority from provisional patent application Ser. No. 60/221,443, attorney docket no. 25791.45, filed on Jul. 28, 2000, (25) U.S. patent application Ser. No. 10/_____, filed on Dec. 18, 2002, attorney docket no. 25791.46.07, which claims priority from provisional patent application Ser. No. 60/221,645, attorney docket no. 25791.46, filed on Jul. 28, 2000, (26) U.S. patent application Ser. No. 10/322,947, filed on Jan. 22, 2003, attorney docket no. 25791.47.03, which claims priority from provisional patent application Ser. No. 60/233,638, attorney docket no. 25791.47, filed on Sep. 18, 2000, (27) U.S. patent application Ser. No. 10/406,648, filed on Mar. 31, 2003, attorney docket no. 25791.48.06, which claims priority from provisional patent application Ser. No. 60/237,334, attorney docket no. 25791.48, filed on Oct. 2, 2000, (28) PCT application US02/04353, filed on Feb. 14, 2002, attorney docket no. 25791.50.02, which claims priority from U.S. provisional patent application Ser. No. 60/270,007, attorney docket no. 25791.50, filed on Feb. 20, 2001, (29) U.S. patent application Ser. No. 10/465,835, filed on Jun. 13, 2003, attorney docket no. 25791.51.06, which claims priority from provisional patent application Ser. No. 60/262,434, attorney docket no. 25791.51, filed on Jan. 17, 2001, (30) U.S. patent application Ser. No. 10/465,831, filed on Jun. 13, 2003, attorney docket no. 25791.52.06, which claims priority from U.S. provisional patent application Ser. No. 60/259,486, attorney docket no. 25791.52, filed on Jan. 3, 2001, (31) U.S. provisional patent application Ser. No. 60/452,303, filed on Mar. 5, 2003, attorney docket no. 25791.53, (32) U.S. Pat. No. 6,470,966, which was filed as patent application Ser. No. 09/850,093, filed on May 7, 2001, attorney docket no. 25791.55, as a divisional application of U.S. Pat. No. 6,497,289, which was filed as U.S. patent application Ser. No. 09/454,139, attorney docket no.

25791.03.02, filed on Dec. 3, 1999, which claims priority from provisional application 60/111,293, filed on Dec. 7, 1998, (33) U.S. Pat. No. 6,561,227, which was filed as patent application Ser. No. 09/852,026, filed on May 9, 2001, attorney docket no. 25791.56, as a divisional application of U.S. Pat. No. 6,497,289, which was filed as U.S. patent application Ser. No. 09/454,139, attorney docket no. 25791.03.02, filed on Dec. 3, 1999, which claims priority from provisional application 60/111,293, filed on Dec. 7, 1998, (34) U.S. patent application Ser. No. 09/852,027, filed on May 9, 2001, attorney docket no. 25791.57, as a divisional application of U.S. Pat. No. 6,497,289, which was filed as U.S. patent application Ser. No. 09/454,139, attorney docket no. 25791.03.02, filed on Dec. 3, 1999, which claims priority from provisional application 60/111,293, filed on Dec. 7, 1998, (35) PCT Application US02/25608, attorney docket no. 25791.58.02, filed on Aug. 13, 2002, which claims priority from provisional application 60/318,021, filed on Sep. 7, 2001, attorney docket no. 25791.58, (36) PCT Application US02/24399, attorney docket no. 25791.59.02, filed on Aug. 1, 2002, which claims priority from U.S. provisional patent application Ser. No. 60/313,453, attorney docket no. 25791.59, filed on Aug. 20, 2001, (37) PCT Application US02/29856, attorney docket no. 25791.60.02, filed on Sep. 19, 2002, which claims priority from U.S. provisional patent application Ser. No. 60/326,886, attorney docket no. 25791.60, filed on Oct. 3, 2001, (38) PCT Application US02/20256, attorney docket no. 25791.61.02, filed on Jun. 26, 2002, which claims priority from U.S. provisional patent application Ser. No. 60/303,740, attorney docket no. 25791.61, filed on Jul. 6, 2001, (39) U.S. patent application Ser. No. 09/962,469, filed on Sep. 25, 2001, attorney docket no. 25791.62, which is a divisional of U.S. patent application Ser. No. 09/523,468, attorney docket no. 25791.11.02, filed on Mar. 10, 2000, which claims priority from provisional application 60/124,042, filed on Mar. 11, 1999, (40) U.S. patent application Ser. No. 09/962,470, filed on Sep. 25, 2001, attorney docket no. 25791.63, which is a divisional of U.S. patent application Ser. No. 09/523,468, attorney docket no. 25791.11.02, filed on Mar. 10, 2000, which claims priority from provisional application 60/124,042, filed on Mar. 11, 1999, (41) U.S. patent application Ser. No. 09/962,471, filed on Sep. 25, 2001, attorney docket no. 25791.64, which is a divisional of U.S. patent application Ser. No. 09/523,468, attorney docket no. 25791.11.02, filed on Mar. 10, 2000, which claims priority from provisional application 60/124,042, filed on Mar. 11, 1999, (42) U.S. patent application Ser. No. 09/962,467, filed on Sep. 25, 2001, attorney docket no. 25791.65, which is a divisional of U.S. patent application Ser. No. 09/523,468, attorney docket no. 25791.11.02, filed on Mar. 10, 2000, which claims priority from provisional application 60/124,042, filed on Mar. 11, 1999, (43) U.S. patent application Ser. No. 09/962,468, filed on Sep. 25, 2001, attorney docket no. 25791.66, which is a divisional of U.S. patent application Ser. No. 09/523,468, attorney docket no. 25791.11.02, filed on Mar. 10, 2000, which claims priority from provisional application 60/124,042, filed on Mar. 11, 1999, (44) PCT application U.S. Ser. No. 02/25727, filed on Aug. 14, 2002, attorney docket no. 25791.67.03, which claims priority from U.S. provisional patent application Ser. No. 60/317,985, attorney docket no. 25791.67, filed on Sep. 6, 2001, and U.S. provisional patent application Ser. No. 60/318,386, attorney docket no. 25791.67.02, filed on Sep.

10, 2001, (45) PCT application U.S. Ser. No. 02/39425, filed on Dec. 10, 2002, attorney docket no. 25791.68.02, which claims priority from U.S. provisional patent application Ser. No. 60/343,674, attorney docket no. 25791.68, filed on Dec. 27, 2001, (46) U.S. utility patent application Ser. No. 09/969,922, attorney docket no. 25791.69, filed on Oct. 3, 2001, which is a continuation-in-part application of U.S. Pat. No. 6,328,113, which was filed as U.S. patent application Ser. No. 09/440,338, attorney docket number 25791.9.02, filed on Nov. 15, 1999, which claims priority from provisional application 60/108,558, filed on Nov. 16, 1998, (47) U.S. utility patent application Ser. No. 10/516,467, attorney docket no. 25791.70, filed on Dec. 10, 2001, which is a continuation application of U.S. utility patent application Ser. No. 09/969,922, attorney docket no. 25791.69, filed on Oct. 3, 2001, which is a continuation-in-part application of U.S. Pat. No. 6,328,113, which was filed as U.S. patent application Ser. No. 09/440,338, attorney docket number 25791.9.02, filed on Nov. 15, 1999, which claims priority from provisional application 60/108,558, filed on Nov. 16, 1998, (48) PCT application U.S. Ser. No. 03/00609, filed on Jan. 9, 2003, attorney docket no. 25791.71.02, which claims priority from U.S. provisional patent application Ser. No. 60/357,372, attorney docket no. 25791.71, filed on Feb. 15, 2002, (49) U.S. patent application Ser. No. 10/074,703, attorney docket no. 25791.74, filed on Feb. 12, 2002, which is a divisional of U.S. Pat. No. 6,568,471, which was filed as patent application Ser. No. 09/512,895, attorney docket no. 25791.12.02, filed on Feb. 24, 2000, which claims priority from provisional application 60/121,841, filed on Feb. 26, 1999, (50) U.S. patent application Ser. No. 10/074,244, attorney docket no. 25791.75, filed on Feb. 12, 2002, which is a divisional of U.S. Pat. No. 6,568,471, which was filed as patent application Ser. No. 09/512,895, attorney docket no. 25791.12.02, filed on Feb. 24, 2000, which claims priority from provisional application 60/121,841, filed on Feb. 26, 1999, (51) U.S. patent application Ser. No. 10/076,660, attorney docket no. 25791.76, filed on Feb. 15, 2002, which is a divisional of U.S. Pat. No. 6,568,471, which was filed as patent application Ser. No. 09/512,895, attorney docket no. 25791.12.02, filed on Feb. 24, 2000, which claims priority from provisional application 60/121,841, filed on Feb. 26, 1999, (52) U.S. patent application Ser. No. 10/076,661, attorney docket no. 25791.77, filed on Feb. 15, 2002, which is a divisional of U.S. Pat. No. 6,568,471, which was filed as patent application Ser. No. 09/512,895, attorney docket no. 25791.12.02, filed on Feb. 24, 2000, which claims priority from provisional application 60/121,841, filed on Feb. 26, 1999, (53) U.S. patent application Ser. No. 10/076,659, attorney docket no. 25791.78, filed on Feb. 15, 2002, which is a divisional of U.S. Pat. No. 6,568,471, which was filed as patent application Ser. No. 09/512,895, attorney docket no. 25791.12.02, filed on Feb. 24, 2000, which claims priority from provisional application 60/121,841, filed on Feb. 26, 1999, (54) U.S. patent application Ser. No. 10/078,928, attorney docket no. 25791.79, filed on Feb. 20, 2002, which is a divisional of U.S. Pat. No. 6,568,471, which was filed as patent application Ser. No. 09/512,895, attorney docket no. 25791.12.02, filed on Feb. 24, 2000, which claims priority from provisional application 60/121,841, filed on Feb. 26, 1999, (55) U.S. patent application Ser. No. 10/078,922, attorney docket no. 25791.80, filed on Feb. 20, 2002, which is a divisional of U.S. Pat. No. 6,568,471, which was filed as patent application Ser. No. 09/512,895,

attorney docket no. 25791.12.02, filed on Feb. 24, 2000, which claims priority from provisional application 60/121,841, filed on Feb. 26, 1999, (56) U.S. patent application Ser. No. 10/078,921, attorney docket no. 25791.81, filed on Feb. 20, 2002, which is a divisional of U.S. Pat. No. 6,568,471, which was filed as patent application Ser. No. 09/512,895, attorney docket no. 25791.12.02, filed on Feb. 24, 2000, which claims priority from provisional application 60/121,841, filed on Feb. 26, 1999, (57) U.S. patent application Ser. No. 10/261,928, attorney docket no. 25791.82, filed on Oct. 1, 2002, which is a divisional of U.S. Pat. No. 6,557,640, which was filed as patent application Ser. No. 09/588,946, attorney docket no. 25791.17.02, filed on Jun. 7, 2000, which claims priority from provisional application 60/137,998, filed on Jun. 7, 1999, (58) U.S. patent application Ser. No. 10/079,276, attorney docket no. 25791.83, filed on Feb. 20, 2002, which is a divisional of U.S. Pat. No. 6,568,471, which was filed as patent application Ser. No. 09/512,895, attorney docket no. 25791.12.02, filed on Feb. 24, 2000, which claims priority from provisional application 60/121,841, filed on Feb. 26, 1999, (59) U.S. patent application Ser. No. 10/262,009, attorney docket no. 25791.84, filed on Oct. 1, 2002, which is a divisional of U.S. Pat. No. 6,557,640, which was filed as patent application Ser. No. 09/588,946, attorney docket no. 25791.17.02, filed on Jun. 7, 2000, which claims priority from provisional application 60/137,998, filed on Jun. 7, 1999, (60) U.S. patent application Ser. No. 10/092,481, attorney docket no. 25791.85, filed on Mar. 7, 2002, which is a divisional of U.S. Pat. No. 6,568,471, which was filed as patent application Ser. No. 09/512,895, attorney docket no. 25791.12.02, filed on Feb. 24, 2000, which claims priority from provisional application 60/121,841, filed on Feb. 26, 1999, (61) U.S. patent application Ser. No. 10/261,926, attorney docket no. 25791.86, filed on Oct. 1, 2002, which is a divisional of U.S. Pat. No. 6,557,640, which was filed as patent application Ser. No. 09/588,946, attorney docket no. 25791.17.02, filed on Jun. 7, 2000, which claims priority from provisional application 60/137,998, filed on Jun. 7, 1999, (62) PCT application U.S. Ser. No. 02/36157, filed on Nov. 12, 2002, attorney docket no. 25791.87.02, which claims priority from U.S. provisional patent application Ser. No. 60/338,996, attorney docket no. 25791.87, filed on Nov. 12, 2001, (63) PCT application U.S. Ser. No. 02/36267, filed on Nov. 12, 2002, attorney docket no. 25791.88.02, which claims priority from U.S. provisional patent application Ser. No. 60/339,013, attorney docket no. 25791.88, filed on Nov. 12, 2001, (64) PCT application U.S. Ser. No. 03/11765, filed on Apr. 16, 2003, attorney docket no. 25791.89.02, which claims priority from U.S. provisional patent application Ser. No. 60/383,917, attorney docket no. 25791.89, filed on May 29, 2002, (65) PCT application U.S. Ser. No. 03/15020, filed on May 12, 2003, attorney docket no. 25791.90.02, which claims priority from U.S. provisional patent application Ser. No. 60/391,703, attorney docket no. 25791.90, filed on Jun. 26, 2002, (66) PCT application U.S. Ser. No. 02/39418, filed on Dec. 10, 2002, attorney docket no. 25791.92.02, which claims priority from U.S. provisional patent application Ser. No. 60/346,309, attorney docket no. 25791.92, filed on Jan. 7, 2002, (67) PCT application U.S. Ser. No. 03/06544, filed on Mar. 3, 2003, attorney docket no. 25791.93.02, which claims priority from U.S. provisional patent application Ser. No. 60/372,048, attorney docket no. 25791.93, filed on Apr. 12, 2002, (68) U.S. patent application Ser. No. 10/331,718,

attorney docket no. 25791.94, filed on Dec. 30, 2002, which is a divisional U.S. patent application Ser. No. 09/679,906, filed on Oct. 5, 2000, attorney docket no. 25791.37.02, which claims priority from provisional patent application Ser. No. 60/159,033, attorney docket no. 25791.37, filed on Oct. 12, 1999, (69) PCT application U.S. Ser. No. 03/04837, filed on Feb. 29, 2003, attorney docket no. 25791.95.02, which claims priority from U.S. provisional patent application Ser. No. 60/363,829, attorney docket no. 25791.95, filed on Mar. 13, 2002, (70) U.S. patent application Ser. No. 10/261,927, attorney docket no. 25791.97, filed on Oct. 1, 2002, which is a divisional of U.S. Pat. No. 6,557,640, which was filed as patent application Ser. No. 09/588,946, attorney docket no. 25791.17.02, filed on Jun. 7, 2000, which claims priority from provisional application 60/137,998, filed on Jun. 7, 1999, (71) U.S. patent application Ser. No. 10/262,008, attorney docket no. 25791.98, filed on Oct. 1, 2002, which is a divisional of U.S. Pat. No. 6,557,640, which was filed as patent application Ser. No. 09/588,946, attorney docket no. 25791.17.02, filed on Jun. 7, 2000, which claims priority from provisional application 60/137,998, filed on Jun. 7, 1999, (72) U.S. patent application Ser. No. 10/261,925, attorney docket no. 25791.99, filed on Oct. 1, 2002, which is a divisional of U.S. Pat. No. 6,557,640, which was filed as patent application Ser. No. 09/588,946, attorney docket no. 25791.17.02, filed on Jun. 7, 2000, which claims priority from provisional application 60/137,998, filed on Jun. 7, 1999, (73) U.S. patent application Ser. No. 10/199,524, attorney docket no. 25791.100, filed on Jul. 19, 2002, which is a continuation of U.S. Pat. No. 6,497,289, which was filed as U.S. patent application Ser. No. 09/454,139, attorney docket no. 25791.03.02, filed on Dec. 3, 1999, which claims priority from provisional application 60/111,293, filed on Dec. 7, 1998, (74) PCT application U.S. Ser. No. 03/10144, filed on Mar. 28, 2003, attorney docket no. 25791.101.02, which claims priority from U.S. provisional patent application Ser. No. 60/372,632, attorney docket no. 25791.101, filed on Apr. 15, 2002, (75) U.S. provisional patent application Ser. No. 60/412,542, attorney docket no. 25791.102, filed on Sep. 20, 2002, (76) PCT application U.S. Ser. No. 03/14153, filed on May 6, 2003, attorney docket no. 25791.104.02, which claims priority from U.S. provisional patent application Ser. No. 60/380,147, attorney docket no. 25791.104, filed on May 6, 2002, (77) PCT application U.S. Ser. No. 03/19993, filed on Jun. 24, 2003, attorney docket no. 25791.106.02, which claims priority from U.S. provisional patent application Ser. No. 60/397,284, attorney docket no. 25791.106, filed on Jul. 19, 2002, (78) PCT application U.S. Ser. No. 03/13787, filed on May 5, 2003, attorney docket no. 25791.107.02, which claims priority from U.S. provisional patent application Ser. No. 60/387,486, attorney docket no. 25791.107, filed on Jun. 10, 2002, (79) PCT application U.S. Ser. No. 03/18530, filed on Jun. 11, 2003, attorney docket no. 25791.108.02, which claims priority from U.S. provisional patent application Ser. No. 60/387,961, attorney docket no. 25791.108, filed on Jun. 12, 2002, (80) PCT application U.S. Ser. No. 03/20694, filed on Jun. 1, 2003, attorney docket no. 25791.110.02, which claims priority from U.S. provisional patent application Ser. No. 60/398,061, attorney docket no. 25791.110, filed on Jun. 24, 2002, (81) PCT application U.S. Ser. No. 03/20870, filed on Jul. 2, 2003, attorney docket no. 25791.111.02, which claims priority from U.S. provisional patent application Ser. No. 60/399,240, attorney docket no. 25791.111, filed on Jul.

29, 2002, (82) U.S. provisional patent application Ser. No. 60/412,487, attorney docket no. 25791.112, filed on Sep. 20, 2002, (83) U.S. provisional patent application Ser. No. 60/412,488, attorney docket no. 25791.114, filed on Sep. 20, 2002, (84) U.S. patent application Ser. No. 10/280,356, attorney docket no. 25791.115, filed on Oct. 25, 2002, which is a continuation of U.S. Pat. No. 6,470,966, which was filed as patent application Ser. No. 09/850,093, filed on May 7, 2001, attorney docket no. 25791.55, as a divisional application of U.S. Pat. No. 6,497,289, which was filed as U.S. patent application Ser. No. 09/454,139, attorney docket no. 25791.03.02, filed on Dec. 3, 1999, which claims priority from provisional application 60/111,293, filed on Dec. 7, 1998, (85) U.S. provisional patent application Ser. No. 60/412,177, attorney docket no. 25791.117, filed on Sep. 20, 2002, (86) U.S. provisional patent application Ser. No. 60/412,653, attorney docket no. 25791.118, filed on Sep. 20, 2002, (87) U.S. provisional patent application Ser. No. 60/405,610, attorney docket no. 25791.119, filed on Aug. 23, 2002, (88) U.S. provisional patent application Ser. No. 60/405,394, attorney docket no. 25791.120, filed on Aug. 23, 2002, (89) U.S. provisional patent application Ser. No. 60/412,544, attorney docket no. 25791.121, filed on Sep. 20, 2002, (90) PCT application PCT/US03/24779, filed on Aug. 8, 2003, attorney docket no. 25791.125.02, which claims priority from U.S. provisional patent application Ser. No. 60/407,442, attorney docket no. 25791.125, filed on Aug. 3, 2002, (91) U.S. provisional patent application Ser. No. 60/423,363, attorney docket no. 25791.126, filed on Dec. 10, 2002, (92) U.S. provisional patent application Ser. No. 60/412,196, attorney docket no. 25791.127, filed on Sep. 20, 2002, (93) U.S. provisional patent application Ser. No. 60/412,187, attorney docket no. 25791.128, filed on Sep. 20, 2002, (94) U.S. provisional patent application Ser. No. 60/412,371, attorney docket no. 25791.129, filed on Sep. 20, 2002, (95) U.S. patent application Ser. No. 10/382,325, attorney docket no. 25791.145, filed on Mar. 5, 2003, which is a continuation of U.S. Pat. No. 6,557,640, which was filed as patent application Ser. No. 09/588,946, attorney docket no. 25791.17.02, filed on Jun. 7, 2000, which claims priority from provisional application 60/137,998, filed on Jun. 7, 1999, (96) U.S. patent application Ser. No. 10/624842, attorney docket no. 25791.151, filed on Jul. 22, 2003, which is a divisional of U.S. patent application Ser. No. 09/502,350, attorney docket no. 25791.8.02, filed on Feb. 10, 2000, which claims priority from provisional application 60/119,611, filed on Feb. 11, 1999, (97) U.S. provisional patent application Ser. No. 60/431,184, attorney docket no. 25791.157, filed on Dec. 5, 2002, (98) U.S. provisional patent application Ser. No. 60/448,526, attorney docket no. 25791.185, filed on Feb. 18, 2003, (99) U.S. provisional patent application Ser. No. 60/461,539, attorney docket no. 25791.186, filed on Apr. 9, 2003, (100) U.S. provisional patent application Ser. No. 60/462,750, attorney docket no. 25791.193, filed on Apr. 14, 2003, (101) U.S. provisional patent application Ser. No. 60/436,106, attorney docket no. 25791.200, filed on Dec. 23, 2002, (102) U.S. provisional patent application Ser. No. 60/442,942, attorney docket no. 25791.213, filed on Jan. 27, 2003, (103) U.S. provisional patent application Ser. No. 60/442,938, attorney docket no. 25791.225, filed on Jan. 27, 2003, (104) U.S. provisional patent application Ser. No. 60/418,687, attorney docket no. 25791.228, filed on Apr. 18, 2003, (105) U.S. provisional patent application Ser. No. 60/454,896, attorney docket no.

25791.236, filed on Mar. 14, 2003, (106) U.S. provisional patent application Ser. No. 60/450,504, attorney docket no. 25791.238, filed on Feb. 26, 2003, (107) U.S. provisional patent application Ser. No. 60/451,152, attorney docket no. 25791.239, filed on Mar. 9, 2003, (108) U.S. provisional patent application Ser. No. 60/455,124, attorney docket no. 25791.241, filed on Mar. 17, 2003, (109) U.S. provisional patent application Ser. No. 60/453,678, attorney docket no. 25791.253, filed on Mar. 11, 2003, (110) U.S. patent application Ser. No. 10/421,682, attorney docket no. 25791.256, filed on Apr. 23, 2003, which is a continuation of U.S. patent application Ser. No. 09/523,468, attorney docket no. 25791.11.02, filed on Mar. 10, 2000, which claims priority from provisional application 60/124,042, filed on Mar. 11, 1999, (111) U.S. provisional patent application Ser. No. 60/457,965, attorney docket no. 25791.260, filed on Mar. 27, 2003, (112) U.S. provisional patent application Ser. No. 60/455,718, attorney docket no. 25791.262, filed on Mar. 18, 2003, (113) U.S. Pat. No. 6,550,821, which was filed as patent application Ser. No. 09/811,734, filed on Mar. 19, 2001, (114) U.S. patent application Ser. No. 10/436,467, attorney docket no. 25791.268, filed on May 12, 2003, which is a continuation of U.S. Pat. No. 6,604,763, which was filed as application Ser. No. 09/559,122, attorney docket no. 25791.23.02, filed on Apr. 26, 2000, which claims priority from provisional application 60/131,106, filed on Apr. 26, 1999, (115) U.S. provisional patent application Ser. No. 60/459,776, attorney docket no. 25791.270, filed on Apr. 2, 2003, (116) U.S. provisional patent application Ser. No. 60/461,094, attorney docket no. 25791.272, filed on Apr. 8, 2003, (117) U.S. provisional patent application Ser. No. 60/461,038, attorney docket no. 25791.273, filed on Apr. 7, 2003, (118) U.S. provisional patent application Ser. No. 60/463,586, attorney docket no. 25791.277, filed on Apr. 17, 2003, (119) U.S. provisional patent application Ser. No. 60/472,240, attorney docket no. 25791.286, filed on May 20, 2003, (120) U.S. patent application Ser. No. 10/619,285, attorney docket no. 25791.292, filed on Jul. 14, 2003, which is a continuation-in-part of U.S. utility patent application Ser. No. 09/969,922, attorney docket no. 25791.69, filed on Oct. 3, 2001, which is a continuation-in-part application of U.S. Pat. No. 6,328,113, which was filed as U.S. patent application Ser. No. 09/440,338, attorney docket number 25791.9.02, filed on Nov. 15, 1999, which claims priority from provisional application 60/108,558, filed on Nov. 16, 1998, (121) U.S. utility patent application Ser. No. 10/418,688, attorney docket no. 25791.257, which was filed on Apr. 18, 2003, as a division of U.S. utility patent application Ser. No. 09/523,468, attorney docket no. 25791.11.02, filed on Mar. 10, 2000, which claims priority from provisional application 60/124,042, filed on Mar. 11, 1999, (122) U.S. utility patent application Ser. No. _____, attorney docket no. 25791.238.02, which was filed on Feb. 26, 2004, which claims the benefit of the filing date of U.S. provisional patent application Ser. No. 60/450,504, attorney docket no. 25791.238, filed on Feb. 26, 2003, (123) U.S. utility patent application Ser. No. _____, attorney docket no. 25791.253.02, which was filed on Mar. 11, 2004, which claims the benefit of the filing date of U.S. provisional patent application Ser. No. 60/453,678, attorney docket number 25791.253, filed on Mar. 11, 2003, (124) U.S. utility patent application Ser. No. _____, attorney docket no. 25791.40.02, which was filed on Mar. 15, 2003, which claims the benefit of the filing date of U.S. provisional patent

application Ser. No. 60/455,051, attorney docket number 25791.40, filed on Mar. 14, 2003, and (125) U.S. utility patent application Ser. No. _____, attorney docket no. 25791.236.02, which was filed on Mar. 15, 2004, which claims the benefit of the filing date of U.S. provisional patent application Ser. No. 60/454,896, attorney docket number 25791.236, filed on Mar. 14, 2003, the disclosures of which are incorporated herein by reference.

BACKGROUND

[0003] This invention relates generally to oil and gas exploration, and in particular to forming and repairing well bore casings to facilitate oil and gas exploration.

[0004] Expandable tubing may be used in, among other applications, the forming and repairing of well bore casings. Typically, an expandable tubing string is lowered into and down a well bore by an expansion apparatus positioned at the bottom of the string. The expansion apparatus is lowered down the well bore via another tubing string that is disposed through the expandable tubing string and connected to the expansion apparatus. Because the expansion apparatus supports the weight of the expandable tubing string, the string is in compression while being carried down the well bore. If the expandable tubing string is comprised of a series of interconnected joints, this compressive state can result in damage to the various joint connections along the expandable tubing string. Also, if the expandable tubing string is long enough, the overall weight of the string may cause the string to compress to such a degree that an unwanted and/or uncontrolled expansion of the string occurs.

[0005] Therefore, what is needed is an apparatus and method for carrying an expandable tubing string in a well bore that overcomes the above-described problems, among others.

BRIEF DESCRIPTION OF THE DRAWINGS

[0006] FIG. 1 is a partial elevational/partial sectional/partial schematic view, not necessarily to scale, depicting a system according to one embodiment, the system including a tool 20, a slip joint 24, a safety sub 28, an expansion apparatus 30 and an expandable member 34 wherein the expansion apparatus 30, among other components, is being lowered.

[0007] FIG. 1a is a partial sectional view, not necessarily to scale, depicting the tool 20 of FIG. 1.

[0008] FIG. 1b is a partial sectional view, not necessarily to scale, depicting the slip joint 24 of FIG. 1.

[0009] FIG. 1c is a partial elevational/partial sectional view, not necessarily to scale, depicting the sub 28 and the expansion apparatus 30 of FIG. 1.

[0010] FIG. 2a is a partial sectional view, not necessarily to scale, depicting the tool 20 of FIG. 1 but showing another operational mode.

[0011] FIG. 2b is a partial sectional view, not necessarily to scale, depicting the slip joint 24 of FIG. 1 but showing another operational mode.

[0012] FIG. 3a is a partial sectional view, not necessarily to scale, depicting the tool 20 of FIG. 1 but showing yet another operational mode.

[0013] FIG. 3b is a partial sectional view, not necessarily to scale, depicting the slip joint 24 of FIG. 1 but showing yet another operational mode.

DETAILED DESCRIPTION

[0014] Referring to FIG. 1 of the drawings, the reference numeral 10 refers to a well bore penetrating a subterranean ground formation F for the purpose of recovering hydrocarbon fluids from the formation, the well bore having a bottom 12. A series of components 14 is lowered into the well bore 10 by a tubular string 16, in the form of coiled tubing, jointed tubing, or the like which is connected to the upper end of the series. The components in the series 14 will be described.

[0015] The string 16 extends from a rig 18 that is located above ground and extends over the well bore 10. The rig 18 is conventional and, as such, includes support structure, a motor driven winch, or the like, and other associated equipment for receiving and supporting the series 14 and lowering it into the well bore 10 by unwinding the string 16 from the winch. The upper portion of the well bore 10 can be lined with a casing 19 in any conventional manner.

[0016] The series 14 includes a tool 20 to which the string 16 is connected. A tubular string 22, in the form of coiled tubing, jointed tubing, or the like, is connected to and extends downward from the tool 20. A slip joint 24 is connected to the lower end of the string 22, and a tubular string 26, in the form of coiled tubing, jointed tubing, or the like, is connected to and extends downward from the slip joint 24 and its lower end is connected to a safety sub 28. An expansion apparatus 30 is connected to the sub 28. The expansion apparatus 30 includes a float shoe 32.

[0017] An expandable tubular member 34 is connected to, and extends downward from, the lower end of the tool 20 to the shoe 32 so that the slip joint 24, the string 26, the sub 28, and the expansion apparatus 30 are all disposed within the member 34. The expansion apparatus 30 is slidably engaged with the internal wall of the member 34. The member 34 is comprised of a plurality of joints (not shown) that are each interconnected via a left hand thread engagement configuration. Thus, the series of components 14 includes the tool 20, the string 22, the slip joint 24, the string 26, the sub 28, the expansion apparatus 30 which includes the shoe 32, and the member 34.

[0018] The lower end portion of the member 34 that extends around the apparatus 30 has an increased diameter, and a variable-dimension annulus 35 is defined by the internal wall of the member 34 and the external walls of the string 22, the slip joint 24 and the string 26. A variable-dimension annulus 36 is also defined between the inner wall of the well bore 10 and the external wall of the member 34.

[0019] Referring to FIG. 1a, an embodiment of the tool 20 is shown and includes an elongated tubular member or coupling 37 to which the string 16 is connected via a conventional drillpipe box thread connection 38. The coupling 37 includes an o-ring 40, a pair of openings 42a and 42b, and an internal straight thread connection 44. Also, the coupling 37 defines a passage 45.

[0020] A mandrel extension 46, in the form of an elongated tubular body member, is connected to the coupling 37 via the thread connection 44, and the o-ring 40 seals against the mandrel extension 46 immediately above this connec-

tion. The mandrel extension 46 includes a pair of openings 48a and 48b that are aligned with the openings 42a and 42b of the coupling 37, and the aligned openings receive two torque pins 50a and 50b, respectively. The mandrel extension 46 further includes an o-ring 52, a pair of openings 54a and 54b, and an internal straight thread connection 55.

[0021] A mandrel 56, also in the form of an elongated tubular body member, is connected to the mandrel extension 46 via the thread connection 55, and the o-ring 52 seals against the mandrel immediately above this connection. The mandrel 56 includes a pair of openings 58a and 58b that are aligned with the openings 54a and 54b, respectively, of the mandrel extension 46. Two torque pins 60a and 60b extend through the aligned openings 54a and 60a, and the aligned openings 54b and 60b, respectively. The mandrel 56 further includes a plurality of external splines 62a and 62b extending downwardly a predetermined distance along the mandrel 56. Each external spline 62a and 62b includes at least one chamfer 64.

[0022] An external shoulder 66 is formed on the mandrel 56 below the external splines 62a and 62b, and a plurality of downward-extending grooves 68 are formed in the shoulder 66 (a side wall of one groove 68 is shown in FIG. 1a). The mandrel 56 further includes a conventional drillpipe pin thread connection 70 to which the string 22 is connected.

[0023] A tubular cap 72 extends around the mandrel 56 and has a plurality of internal splines 74a and 74b formed therein which are engaged with the external splines 62a and 62b, respectively, of the mandrel 56. Each of the splines 74a and 74b has at least one chamfer 76 (not shown) which is adapted to engage a corresponding chamfer 64 of the mandrel 56. The cap 72 further includes a radial surface 78 that is engaged with the shoulder 66 of the mandrel 56, and a pair of fluid ports 80a and 80b are formed in the cap 72 at a predetermined distance below the surface 78. An annular recess 82 is formed in the cap 72 at a predetermined distance below the fluid ports 80a and 80b, and receives an anti-torque ring 84, which is made of a conventional low-friction material. The cap 72 further includes an internal right hand straight thread connection 86.

[0024] A casing adapter 88, in the form of an elongated tubular member, is connected to the cap 72 via the connection 86 and the anti-torque ring 84 is adapted to allow the cap 72 to be removably connected to the casing adapter 88. Since the anti-torque ring 84 is conventional, it will not be described in further detail. The casing adapter 88 extends downwardly and includes an internal left hand thread connection 90 to which the member 34 is connected. It is understood that the connection 86 may be tightened until the casing adapter 88 firmly shoulders against the anti-torque ring 84 and the recess 82 in the cap 72, and then the casing adapter 88 may be backed off of at least a portion of the threads in the connection 86 so as to prevent any inadvertent right hand torque from being applied to the top of the member 34 and thereby loosen the aforementioned left hand threaded joint interconnections of the member 34.

[0025] Referring to FIG. 1b, an embodiment of the slip joint 24 is shown within the expandable tubular member 34 and includes a tubular member 92 having a conventional drillpipe box thread connection 94 to which the string 22 is connected. The bore of the member 92 is stepped to define three concentric inner passages 96, 98 and 100 of increasing

diameter in a downwardly direction, as viewed in FIG. 1b. An o-ring 101 is retained in an annular channel extending circumferentially about the passage 98.

[0026] The upper end portion of a tubular member 102 is connected to the lower end portion of the tubular member 92 via a threaded connection 103 and a pair of torque pins 104a and 104b. The tubular member 102 defines a passage 106 and includes a pair of protrusions 108a and 108b extending upwardly from the connection 103. A pair of channels 110a and 110b are formed in the bottom portion of the tubular member 102 (one inner side wall of each channel 110a and 110b are shown in FIG. 1b).

[0027] The slip joint 24 also includes an elongated tubular member 112 which is disposed in the passages 98, 100 and 106. The tubular member 112 includes an upper portion 114 that is slidably engaged with a portion of the internal wall of the passage 98 of the tubular member 92, with the o-ring 101 sealing against the upper portion 114. A integral flange or ring 116 extends radially outward from the tubular member 112 and a pair of channels 118a and 118b are formed therein (one inner side wall of each channel 118a and 118b are shown in FIG. 1b). The channels 118a and 118b are configured to couple with the protrusions 108a and 108b, respectively, of the tubular member 102.

[0028] A tubular member 120 also forms part of the slip joint 24, defines an internal passage 121, and is connected to the tubular member 112 via a threaded connection 122 and a pair of torque pins 124a and 124b. The tubular member 120 has a pair of protrusions 126a and 126b extending upwardly from the connection 122 and configured to couple with the channels 110a and 110b, respectively, of the tubular member 102. The tubular member 120 further includes an o-ring 127 which is sealed against a bottom portion of the tubular member 112, and a conventional drillpipe pin thread connection 128 to which the string 26 is connected.

[0029] Referring to FIG. 1c, an embodiment of the expansion apparatus 30 is shown within the tubular member 34. The upper end of the apparatus 30 is connected to the sub 28 in any conventional manner, and the sub 28 is connected to the string 26 via a conventional drillpipe box thread connection 130.

[0030] The expansion apparatus 30 includes an expansion cone portion 132 that engages the inner wall of the member 34. The shoe 32 of the expansion apparatus 30 is connected to the member 34 via a threaded connection 134 and a pair of radially-extending threaded fasteners 136a and 136b are disposed through the member 34 and into the shoe 32. The sub 28 and the expansion apparatus 30 are designed so that torque may be transmitted from the string 26 to the member 34 via the shoe 32. To this end, the expansion apparatus 30 may be in the form of one of several existing expansion apparatuses, such as, for example, the expansion apparatus disclosed in detail in co-pending U.S. patent application Ser. No. _____ (attorney's docket no. 25791.238.02), which claims the benefit of the filing date of U.S. provisional patent application Ser. No. 60/450,504, attorney docket no. 25791.238, filed on Feb. 26, 2003, the disclosure of which is incorporated herein by reference.

[0031] The operation will be described in connection with the general goal of placing the expandable apparatus 30 at the bottom 12 of the well bore 10 and conditioning it for

expansion in a manner to be described. To this end, the string 16 and the series of components 14 are lowered in the well bore 10.

[0032] During this lowering, the external splines 62a and 62b of the mandrel 56 are engaged with the internal splines 74a and 74b of the cap 72, and the surface 78 of the cap 72 is in contact with the shoulder 66, as described above. Also, the tubular member 34 is in tension since its weight is primarily carried by the shoulder 66 of the mandrel 56 of the tool 20 and neither the above-described joints nor the joint interconnections of the member 34 undergo compression due to the weight of the expandable tubular member. Further, the fluid ports 80a and 80b allow fluid to flow from the well bore 10 and into the annulus 35, or vice versa, and the o-rings 40 and 52 provide a fluid seal between the well bore 10 and the passage 45 of the tool 20. Moreover, the o-ring 101 provides a fluid seal between the passage 100 and the passage 98 of the slip joint 24, and the o-ring 127 provides a fluid seal between the annulus 35 and the passage 121.

[0033] The lowering continues until the shoe 32 of the expansion apparatus 30 reaches the bottom 12 of the well bore 10. However, during this movement, a relatively high predetermined displacement resistance may be encountered as a result of (1) the shoe 32 reaching a relatively narrow or collapsed section of the well bore 10, (2) the shoe 32 or the member 34 becoming jammed or stuck in the well bore, (3) the friction between the member 34 and the well bore 10 being too high, or (4) any similar resistance.

[0034] If a resistance is encountered, the string 16 is further lowered into the well bore 10 which also lowers the mandrel extension 46, the mandrel 56, the string 22, the member 92 and the member 102 relative to the expansion apparatus 30, the shoe 32, the sub 28, the member 34, the cap 72, the members 112 and 120 and the string 26 which are prevented from further movement by the resistance. This causes the external splines 62a and 62b of the mandrel 56 to disengage from the internal splines 74a and 74b of the cap 72, respectively, and the shoulder 66 of the mandrel 56 to disengage from the surface 78 of the cap 72, as shown in FIG. 2a. Also, since the tubular member 120 is stationary in the well bore 10, the above lowering of the tubular member 102 causes the channels 110a and 110b of the member 102 to engage the protrusions 126a and 126b, respectively, of the tubular member 120 and thus connect the member 102 to the member 120 as shown in FIG. 2b, and therefore to the string 26, the expansion apparatus 30, and the tubular member 34. It is noted that the grooves 68 allow fluid to flow between the annulus 35 and the ports 80a and 80b.

[0035] In this position, a torque from the rig 18 is applied to the string 16 in any conventional manner, to rotate the string 16 clockwise, as viewed downwardly towards the bottom 12 of the well bore 10, to apply a right hand torque that is transmitted from the string 16 through the coupling 37, the mandrel extension 46, the mandrel 56, the string 22, the tubular member 92, the tubular member 102, the tubular member 120, the string 26, the sub 28, the expansion apparatus 30, the shoe 32 and the member 34, due to the above-described connections between these components. However, it is noted that even though the cap 72 will rotate due to its connection with the member 34, torque is not directly transferred between the mandrel 56 and the cap 72 since the external splines 62a and 62b of the mandrel 56 are

spaced, and therefore disengaged, from the internal splines 74a and 74b, respectively, of the cap 72.

[0036] This torque thus causes the shoe 32 and the member 34 to rotate in a clockwise direction, as defined above and hopefully free them from the above-described resistance, thus allowing the string 16 and the series of components 14 to be lowered further until the shoe 32 reaches the bottom 12 of the well bore 10. Due to the above-described left hand thread engagement configuration of the various joint interconnections of the member 34, the interconnections are not loosened due to this rotation.

[0037] Assuming that the shoe 32 reaches the bottom 12 of the well bore 10 either directly by the lowering operation described above, or as a result of the shoe 32 and/or the member 34 being freed up as described above, and further lowered as necessary, the expansion apparatus 30 can be conditioned for expansion in the following manner.

[0038] In particular, the string 16, and therefore the coupling 37, the mandrel extension 46 and the mandrel 56, are raised as necessary in order to directly connect the mandrel 56 with the cap 72 by engaging the external splines 62a and 62b of the mandrel with the internal splines 74a and 74b, respectively, of the cap, and by engaging the shoulder 66 of the mandrel 56 with the surface 78 of the cap 72. This also raises the string 22 and the tubular members 92 and 102 of the slip joint 24, thereby disengaging the channels 110a and 110b from the protrusions 126a and 126b, respectively and thus disconnecting the member 102 from the member 120.

[0039] Left hand torque is then applied to the string 16, thereby rotating the string 16 in a counterclockwise direction towards the bottom 12 of the well bore 10. This torque is transmitted from the string 16, through the coupling 37, the mandrel extension 46, the mandrel 56, and to the string 22. The mandrel 56 also transmits the torque directly to the cap 72, via the engagement of the splines 62a and 74a, and 62b and 74b. Thus, the cap 72 is rotated counterclockwise until it disengages from the threaded connection 86 and therefore the casing adapter 88. It is understood that, during this rotation, the anti-torque ring 84 functions in a conventional manner, allowing the cap 72 to be removed from the casing adapter 88. However, during this rotation, the torque is not transmitted from the string 22 to the string 26 since there is no engagement between the members 102 and 112, nor between the members 102 and 120, as described above and as shown in FIG. 1b.

[0040] Once the cap 72 is disengaged from the casing adapter 88 in the above manner as shown in FIG. 3a, the string 16 is raised further, thereby raising the coupling 37, the mandrel extension 46, the mandrel 56, the cap 72 (via the shoulder 66 of the mandrel 56) and the string 22. As the string 22 is raised, the tubular members 92 and 102 are also raised until the protrusions 108a and 108b of the member 102 engage the channels 118a and 118b of the member 112, as shown in FIG. 3b. This places the components in condition for an expansion procedure in which the expansion apparatus 30 expands the tubular member 34. In this context, one of several existing expansion procedures may be employed to expand the member 34 such as, for example, the methods disclosed in detail in co-pending U.S. patent application Ser. No. _____ (attorney's docket no. 25791.238.02), which claims the benefit of the filing date of U.S. provisional patent application Ser. No. 60/450,504,

attorney docket no. 25791.238, filed on Feb. 26, 2003, the disclosure of which is incorporated herein by reference.

[0041] It is understood that the above-mentioned right hand torque can be applied to the string 16 to rotate the shoe 32 and the member 34 for reasons other than those discussed above. For example, before the cap 72 is disengaged from the adapter 88, and therefore the member 34 in the above manner, it is sometimes desired to introduce a hardenable fluidic sealing material into at least a lower region of the annulus 36 between the member 34 and the wall of the well bore 10. To this end, the sealing material would be introduced from the rig 18 into the string 16 and pass through the tool 20, the string 22, the slip joint 24, the string 26 and the expansion apparatus 30 and flow into at least a lower region of the annulus 36 between the member 34 and the wall of the well bore 10. In this situation, the application of right hand torque in the above manner to rotate the member 34 would more evenly distribute the sealing material in the lower region of the annulus 36. In this context, examples of methods for employing the sealing material in the above manner are disclosed in detail in co-pending U.S. patent application Ser. No. _____ (attorney's docket no. 25791.238.02), which claims the benefit of the filing date of U.S. provisional patent application Ser. No. 60/450,504, attorney docket no. 25791.238, filed on Feb. 26, 2003, the disclosure of which is incorporated herein by reference. Also, it is understood that the above-mentioned right hand torque can be applied in known casing drilling applications.

[0042] It is also noted that when the above components are in condition for an expansion procedure, the series of components 14 may be entirely positioned below the casing 19, or the series may be entirely positioned within the casing, or a portion of the series may be within the casing 19 and another portion of the series may be below the casing 19, such as, for example, the tool 20 being positioned within the casing 19 and the majority of the member 34 being positioned below the casing 19.

Variations

[0043] It is understood that variations may be made in the foregoing without departing from the scope of the invention. For example, the teachings of the present illustrative embodiments may be used to provide a well bore casing, a pipeline, or a structural support. Furthermore, the elements and teachings of the various illustrative embodiments may be combined in whole or in part in some or all of the illustrative embodiments. Further examples of variations are as follows:

[0044] 1. The mandrel extension 46 may be combined with the mandrel 56 to form an integral component.

[0045] 2. Additional external splines may be added to the mandrel 56, and additional corresponding internal splines may be added to the cap 72.

[0046] 3. Additional grooves and fluid ports for fluid flow may be formed in the shoulder 66 and the cap 72, respectively.

[0047] 4. Conventional supporting structures such as, for example, solid centralizers or standoffs, may be added in any conventional manner in order to decrease the possibility of the member 34 buckling during the above-described operation.

[0048] 5. Instead of or in addition to torque pins, other conventional mechanisms may be used to rotatably lock the above-described rotatably-locked connections.

[0049] 6. Additional channels may be formed in the tubular member 112 of the slip joint 24 and these additional channels may be coupled to additional protrusions that may be added to the tubular member 102.

[0050] 7. Additional channels may be formed in the tubular member 102 of the slip joint 24 and these additional channels may be coupled to additional protrusions that may be added to the tubular member 120.

[0051] 8. Instead of or in addition to using the above-described channels and protrusions of the tubular member 102, the channels of the tubular member 112, and the protrusions of the tubular member 120, it is understood that other conventional torque transmission mechanisms may be used to selectively transmit torque between the tubular member 102 and the tubular member 112, and to selectively transmit torque between the tubular member 102 and the tubular member 120.

[0052] 9. It is understood that the foregoing disclosure may be employed in many different applications, including cased hole applications or openhole applications and all types and variations thereof.

[0053] 10. In addition to a vertical well bore as shown in FIGS. 1 and 2, it is understood that the foregoing disclosure may be applied to horizontal well bores and multilateral wells, including main well bores and all branches thereof.

[0054] Spatial references, such as "upper", "lower", "above", "below", "between", "vertical", "bottom", "angular", etc., are for the purpose of illustration only and do not limit the specific orientation or location of the structure described above.

[0055] Although illustrative embodiments of the invention have been shown and described, a wide range of modifications, changes and substitutions is contemplated in the foregoing disclosure. In some instances, some features of the present invention may be employed without a corresponding use of the other features. Accordingly, it is appropriate that the appended claims be construed broadly and in a manner consistent with the scope of the invention. In the claims, means-plus-function clauses are intended to cover the structures described herein as performing the recited function and not only structural equivalents, but also equivalent structures.

What is claimed is:

1. A tubular apparatus comprising:

- a first tubular member adapted to be lowered into a well bore;
- a second tubular member connected to the first tubular member; and
- a third tubular member normally connected to the first tubular member and disconnected from the second tubular member, and adapted for movement relative to the first and second tubular members to disconnect from the first tubular member and connect to the second tubular member.

2. The apparatus of claim 1 wherein the third tubular member moves relative to the first and second tubular

members in response to at least one of the first and second tubular members encountering a resistance in the well bore.

3. The apparatus of claim 1 wherein the third tubular member moves axially relative to the first and second tubular members.

4. The apparatus of claim 1 or 2 further comprising means for applying a torque to the third tubular member when it has been disconnected from the first tubular member and connected to the second tubular member.

5. The apparatus of claim 4 where the torque is transferred from the third tubular member to the second tubular member to enable the resistance to be overcome.

6. The apparatus of claim 3 wherein the third tubular member moves in one direction relative to the first and second tubular members in response to one of the members encountering a predetermined resistance in the well bore.

7. The apparatus of claim 6 wherein the third tubular member is adapted to move relative to the first and second tubular members in a direction opposite the one direction to disconnect from the second tubular member and reconnect with the first tubular member.

8. The apparatus of claim 7 further comprising means for applying a torque to the third tubular member after the first tubular member has been disconnected from the second tubular member and reconnected to the first tubular member.

9. The apparatus of claim 8 further comprising a fourth tubular member threadedly connected to the first tubular member, and wherein the torque is transferred from the third tubular member to the first tubular member to disconnect the threaded connection between the fourth tubular member and the first tubular member.

10. The apparatus of claim 1 further comprising means for introducing a sealing material through the tubular members for passage into the well bore, and means for applying a torque to the third tubular member when it has been disconnected from the first tubular member and connected to the second tubular member to transfer the torque from the third tubular member to the second tubular member to distribute the material in the well bore.

11. A method comprising:

lowering a first tubular member into a well bore;

connecting a second tubular member to the first tubular member;

connecting a third tubular member to the first tubular member; and

moving the third tubular member relative to the first and second tubular members to disconnect the third tubular member from the first tubular member and connect the third tubular member to the second tubular member.

12. The method of claim 11 wherein the third tubular member moves relative to the first and second tubular members in response to at least one of the first and second tubular members encountering a resistance in the well bore.

13. The method of claim 11 wherein the third tubular member moves axially relative to the first and second tubular members.

14. The method of claim 11 or 12 further comprising applying a torque to the third tubular member after the step of moving.

15. The method of claim 14 where the torque is transferred from the third tubular member to the second tubular member to enable the resistance to be overcome.

16. The method of claim 13 wherein the third tubular member moves in one direction relative to the first and second tubular members in response to one of the members encountering a predetermined resistance in the well bore.

17. The method of claim 16 further comprising moving the third tubular member relative to the first and second tubular members in a direction opposite the one direction to disconnect from the second tubular member and reconnect with the first tubular member.

18. The method of claim 17 further comprising applying a torque to the third tubular member after the first tubular member has been disconnected from the second tubular member and reconnected to the first tubular member.

19. The method of claim 18 further comprising threadedly connecting a fourth tubular member to the first tubular member, and wherein the torque is transferred from the third tubular member to the first tubular member to disconnect the threaded connection between the fourth tubular member and the first tubular member.

20. The method of claim 11 further comprising introducing a sealing material through the tubular members for passage into the well bore, and applying a torque to the third tubular member when it has been disconnected from the first tubular member and connected to the second tubular member to transfer the torque from the third tubular member to the second tubular member to distribute the material in the well bore.

21. A method comprising:

connecting an apparatus to an upper portion of an expandable tubular member to place the expandable tubular member in tension; and lowering the apparatus and the expandable tubular member into a well bore, the apparatus supporting at least a portion of the expandable tubular member during the lowering.

22. The method of claim 21 further comprising applying torque to the expandable tubular member.

23. The method of claim 21 further comprising placing the apparatus and the expandable tubular member in condition for an expansion procedure.

24. The method of claim 22 further comprising placing the apparatus and the expandable tubular member in condition for an expansion procedure.

25. The method of claim 21 further comprising applying torque to the apparatus and transmitting the torque to the expandable tubular member.

26. The method of claim 25 further comprising overcoming a resistance in the well bore.

27. The method of claim 25 further comprising introducing a sealing material into the well bore and further comprising distributing the material in the well bore during the transmitting of the torque to the expandable tubular member.

28. The method of claim 25 further comprising placing the apparatus and the expandable tubular member in condition for an expansion procedure.

29. The method of claim 26 further comprising placing the apparatus and the expandable tubular member in condition for an expansion procedure.

30. The method of claim 27 further comprising placing the apparatus and the expandable tubular member in condition for an expansion procedure.

31. The method of claim 21 wherein a tubular member of the apparatus is connected to the upper portion of the expandable tubular member.

32. The method of claim 31 further comprising applying torque to the apparatus and transmitting the torque to the expandable tubular member and to the tubular member of the apparatus.

33. The method of claim 32 further comprising disconnecting the tubular member of the apparatus from the

apparatus and placing the apparatus and the expandable tubular member in condition for an expansion procedure.

34. The method of claim 31 further comprising disconnecting the tubular member of the apparatus from the apparatus and placing the apparatus and the expandable tubular member in condition for an expansion procedure.

* * * * *