

(19)
(12)

(KR)
(A)

(51) 。 Int. Cl. ⁷
H01L 21/283

(11)
(43)

2002 - 0002574
2002 01 10

(21) 10 - 2000 - 0036784
(22) 2000 06 30

(71)

136 - 1

(72)

가 105 - 1305
97 - 3 201 - 1705

(74)

:

(54)

, 1 1 ; 1
2 ; 2
3 ; 2
2 4 ; 2
가 2
5 .

5c

, , , , ,

1 ,
 2 1 A - A' ,
 3a 3b 1 B - B' ,
 4a 4b 1 C - C' ,
 5a 5d ,
 6a 6c 5c - ,

*

31 : 37 : /

38 : 1 39 : 1

40a : Ti/TiN 40b :

40c : 41 : 2

41a : 2 42 : 2

, ,
 , 1 2a 2f .

1 , (16) (21)
 (22a)가 , (21) 1 () 2 (23)
 , 2 (23) (22a) , 2 (23) 2
 (22a) , 2 (23)
 (24)가 가 가 .

2 1 A - A' , 2
 1 C - C' , 3a 3b 1 B - B' , 4a 4b

2 (12), (13), (14), (15), (16), (17) / (18) (11) () (14), (13), (12) (15) (16) (16) (17) (16)

20) (16) 1 (19) / (18) 1 1 (

1 (20) / (18) (21) (21) (21)가
 Ti/TiN(21a), (21b), (21c)

(21) 2 (22) (22) 2 (23) 가

'24' 2 (22) 2 (23) (21) (25)가 (23) (Void)(25)가

3a (21) (21) 2 (22) (22) (21)

3b 2 (23) (24)
 (26) Ti/TiN (22a) 2 '27' (22a) (26)

4a (22) 2 (23) (21) (25)가

4b (22a)(3b) (25) (23) ('24') (23) (25)가 2

5)가 (22a) (25) 가 (23) (21) 2 (23) (23) (2)

(24) , 2 (23) (25)가
 (25) 2 (22) (Recess) (26)
 (Storage node; SN) (26) (Bridge)

(22a) , 2 (23) 2 (23) 2 가

1 ; 1 1
 2 ; 2
 2 3 ; 2
 2 4 ; 2
 5 가

가 가
 가

5a 5d 1
 2

5a (31) () (31)
 (32), (33), (34), (35)
 (35), (34), (33), (32)

(36)
 / (37)

(39) , 1 (38) , 1 (38) 1
 / (37)

6a , 1 (39) / (37)

Ti/TiN(40a), (40b), (40c) (40d)
 가 .

(40d) , 2 (41)
 , 2 가 ,

5b , (Blanket etchback) , 5a '43'
 2 (41) 2
 (41a) (40c) 가 10:1 15:1 가 (Etch recipe)

(40c) .

2 (42)

5c , 2 (41a) 2 (42)
 , 2 (41a) (43) 2 (42)
 (42a). , 2 (42) , (40c)
 , 2 (42)

2 (41a) 가 100:1 2
 (41a) 2 (42)
 , 2 (42) 2 (41a)
 . 42a 2

5d , 2 (41a)
 2 (41a)
 (41a) 가 , (40c) 2 (42a) 10:1 2 가
 .

2 (41a)
 (44)

6a 6c , 5d - '
 2

6a , 1 (38) , 1 (38)

/ (37) 1 (39) 1 (39) Ti/TiN(40a),
(40b), (40c) (40d)가

, 2 (41) , 2 가

6b , (40c) (43) 2 (41a) ,
(Etch recipe) (40c)

가 10:1 가 (40c)

2 (42)

6c , 2 (41a) 2 (42)
00:1 , 2 (42) 2 (41a) 가 1
0c) (42) , 2 (42) , (43) 2 (4

, 2 (41a) 가 100:1 2
(41a) , 2 (42)
, 2 (42) 2 (41a)

가 가 , 가

, 2 2 2 2
가 가 .

, 2 가 .

(57)

1.

1 1 ;

1 2 ;

2 3 ;

4 ; 2

2 , 2 가 5

2.

1 ,

4 ,

가 가

3.

1 ,

5 ,

2

4.

3 ,

2

가 10:1 15:1

5.

1 ,

6.

1 ,

Ti/TiN,

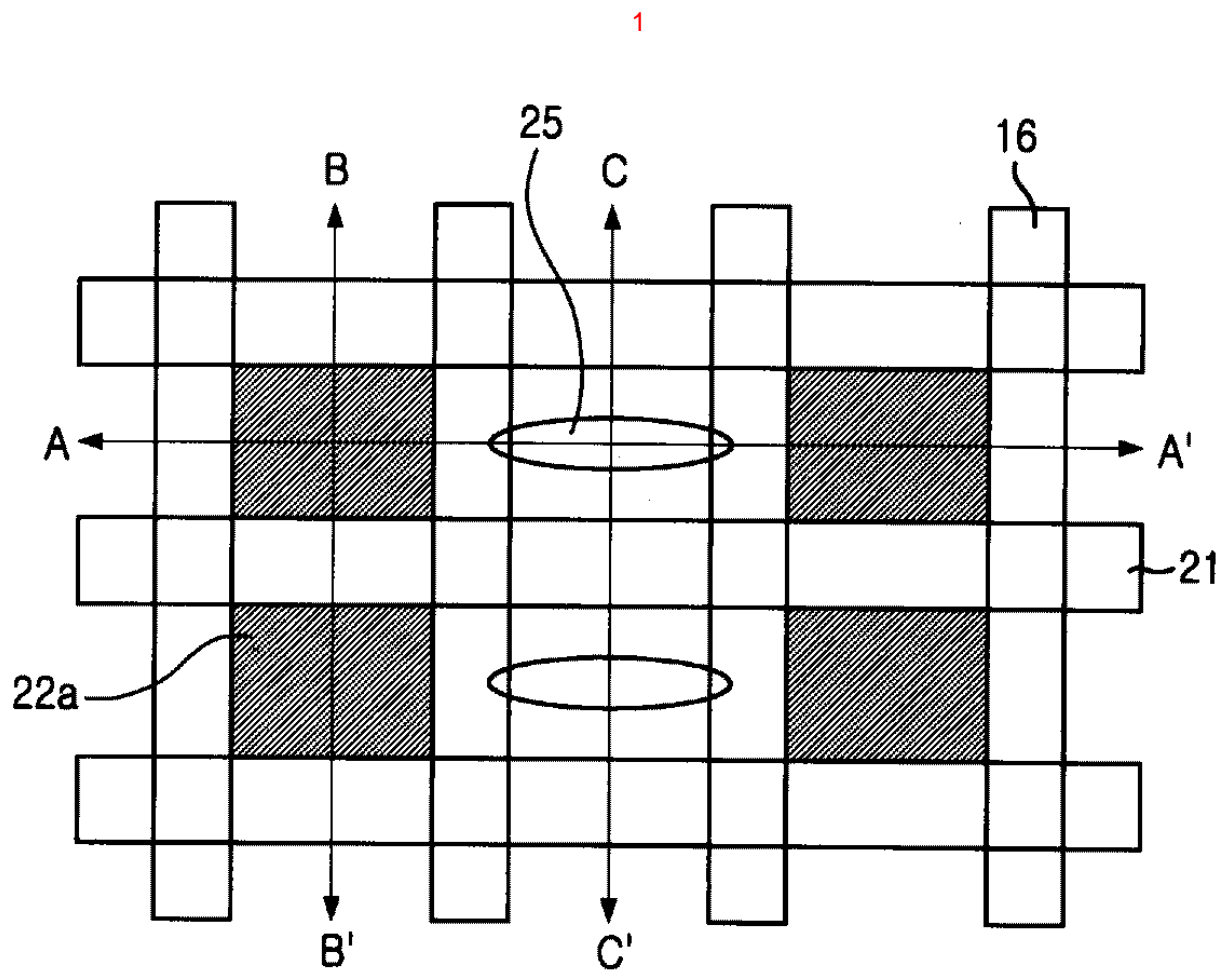

2

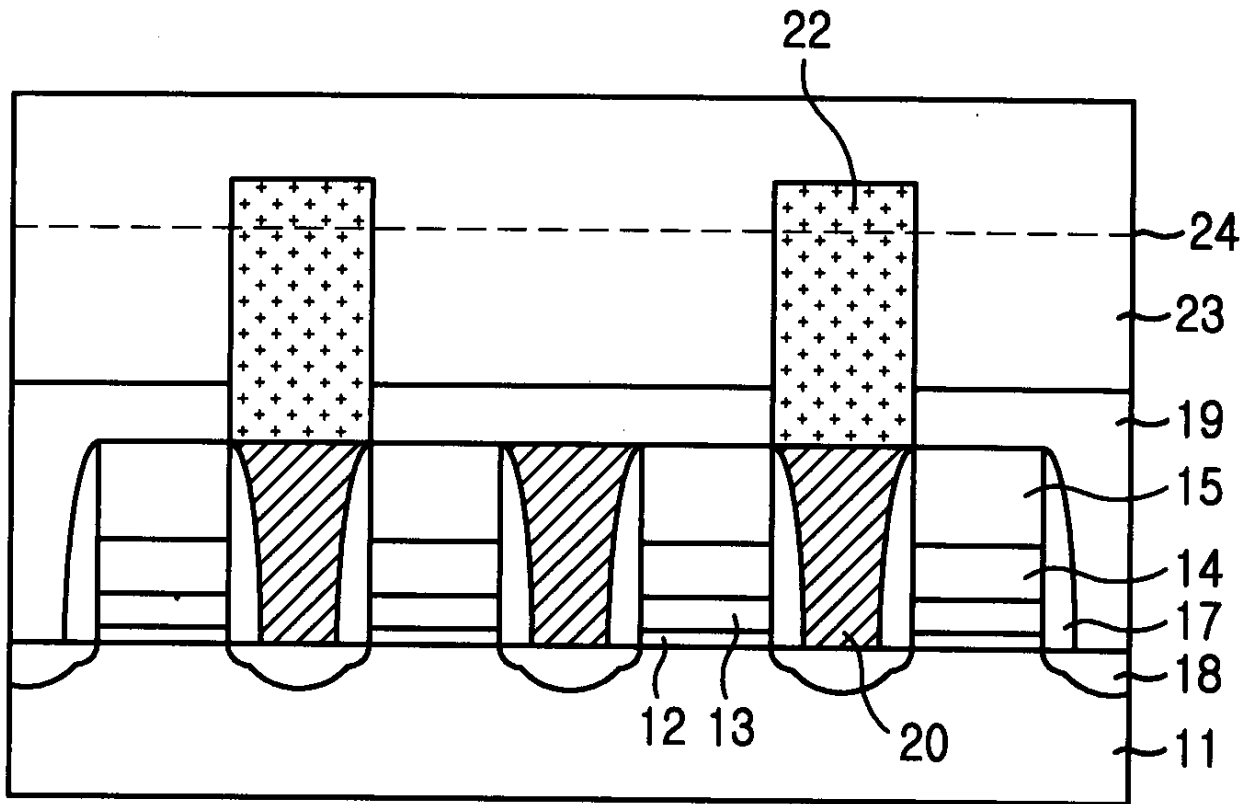

3a

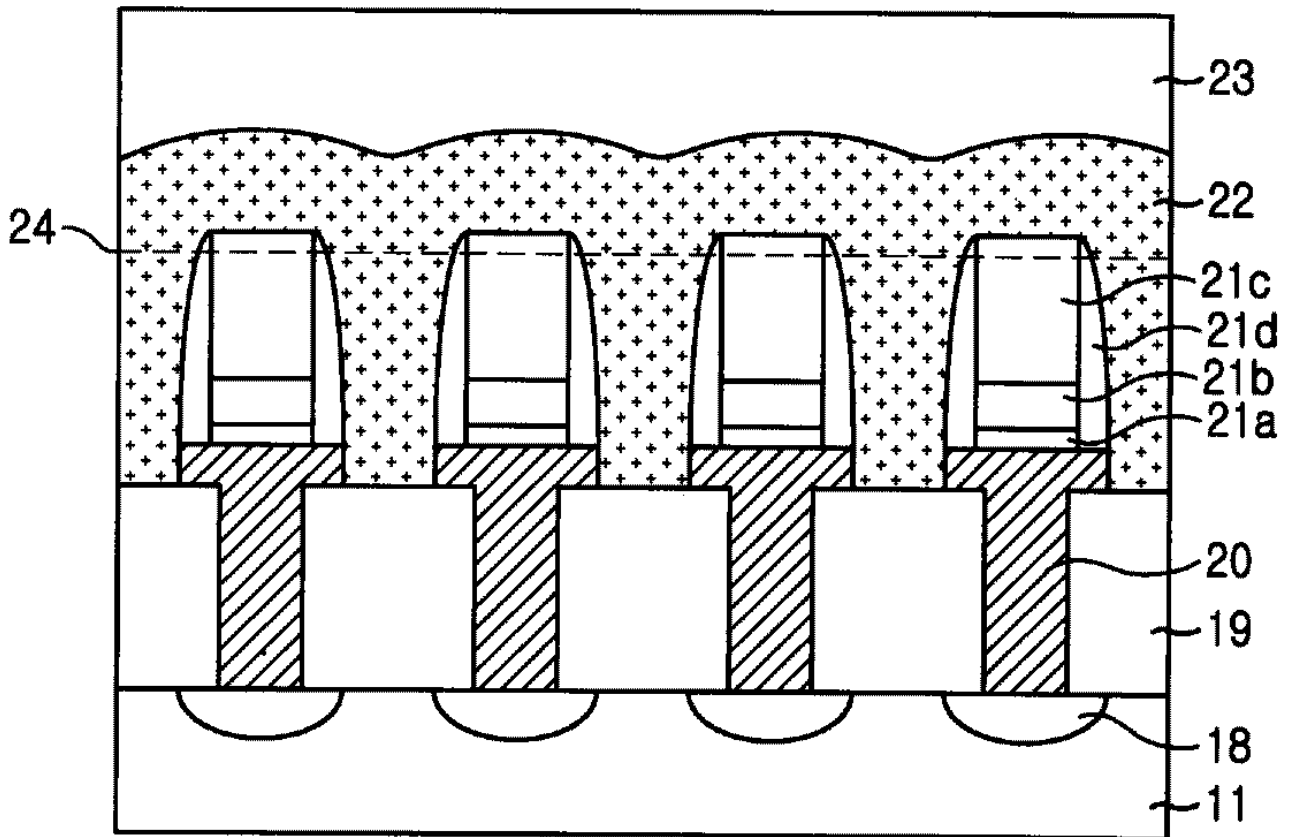

3b

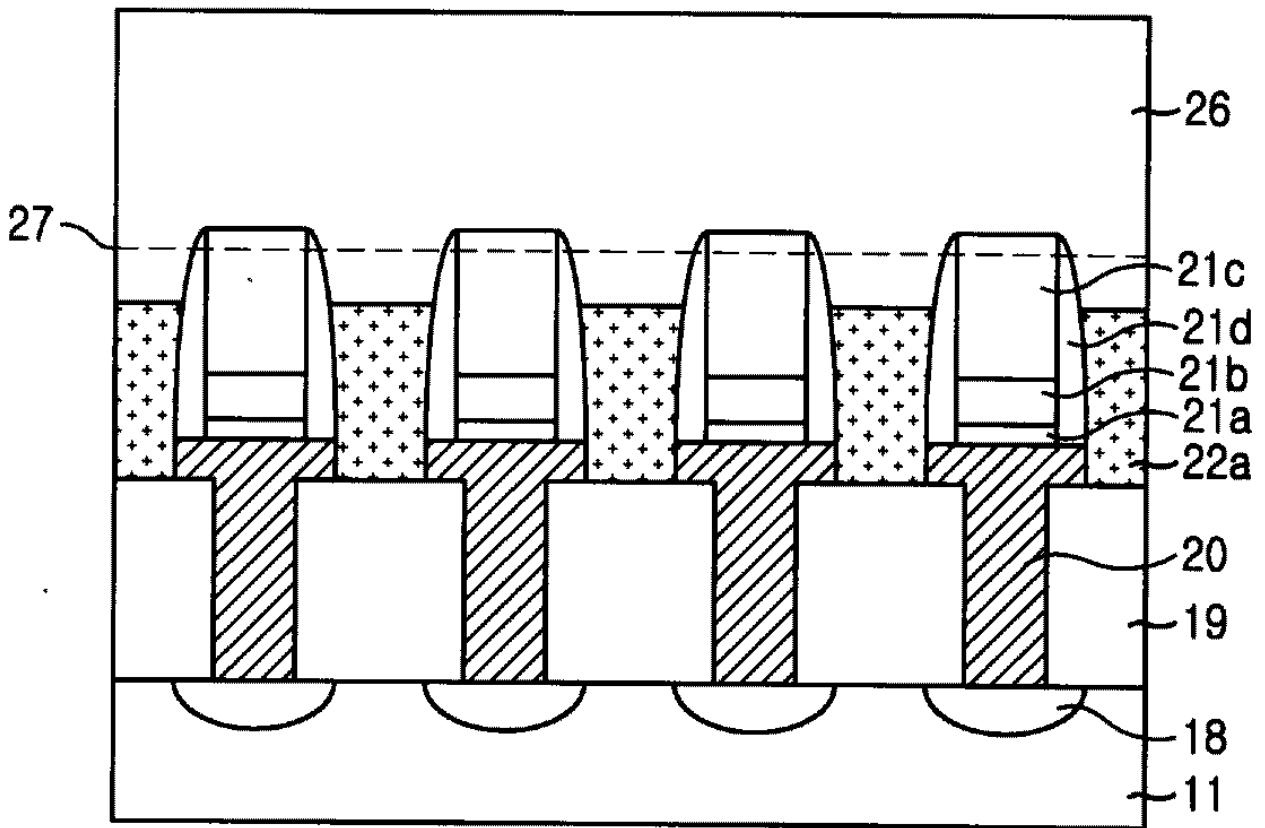

4a

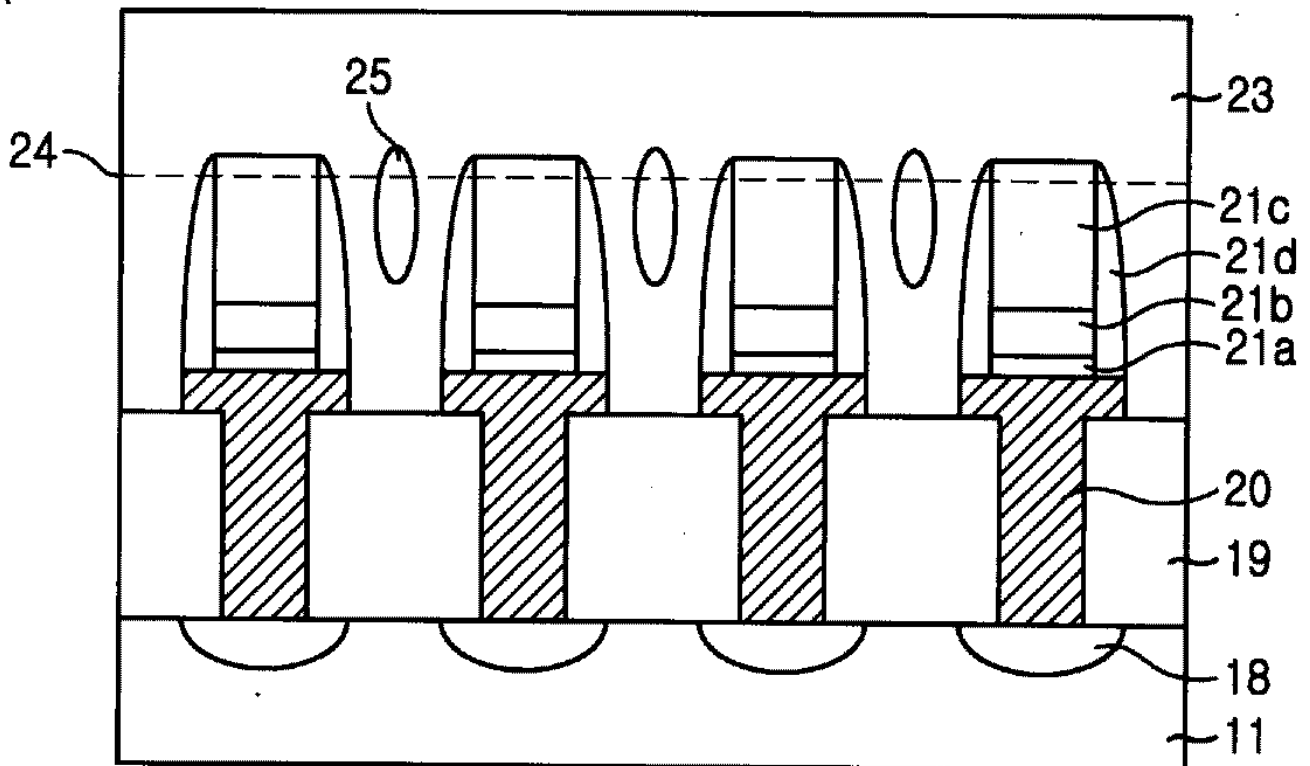

4b

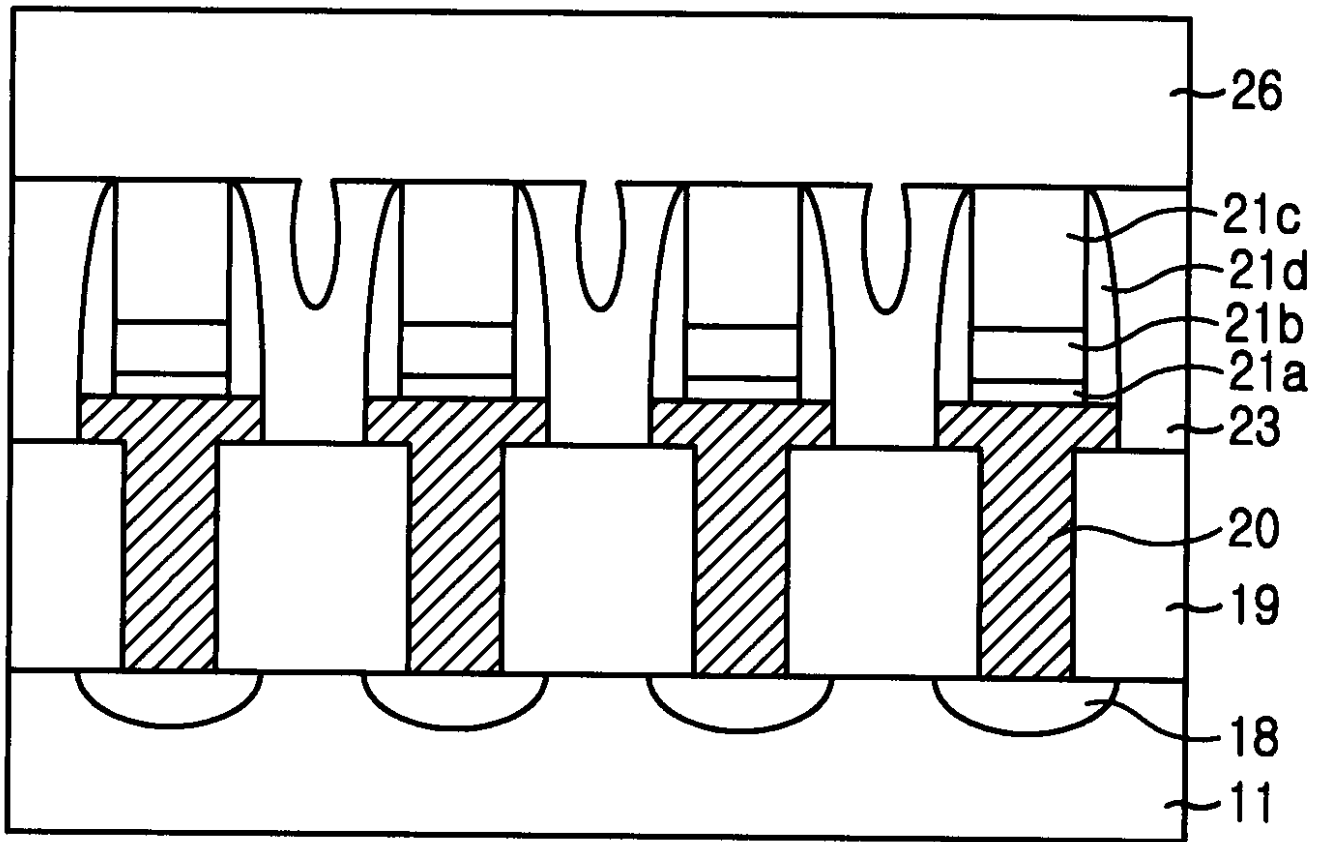

5a

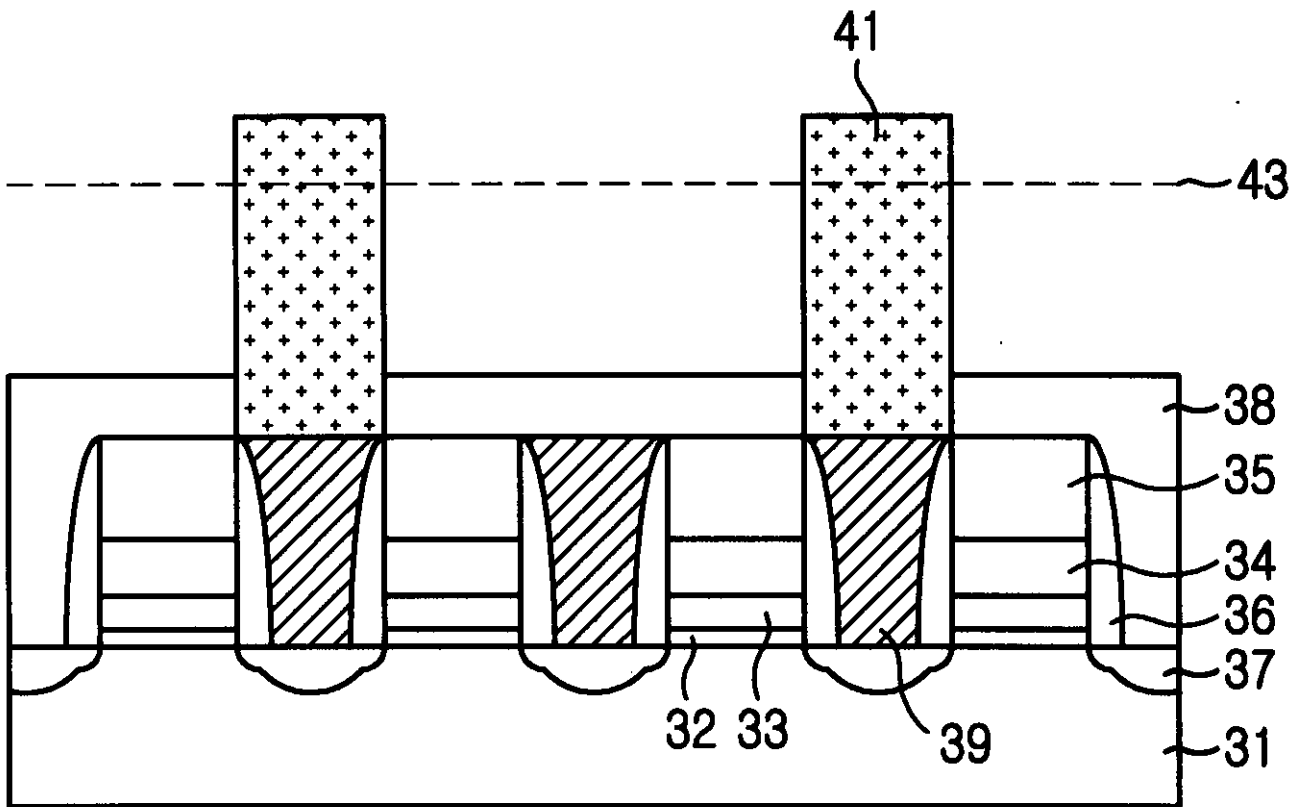

5b

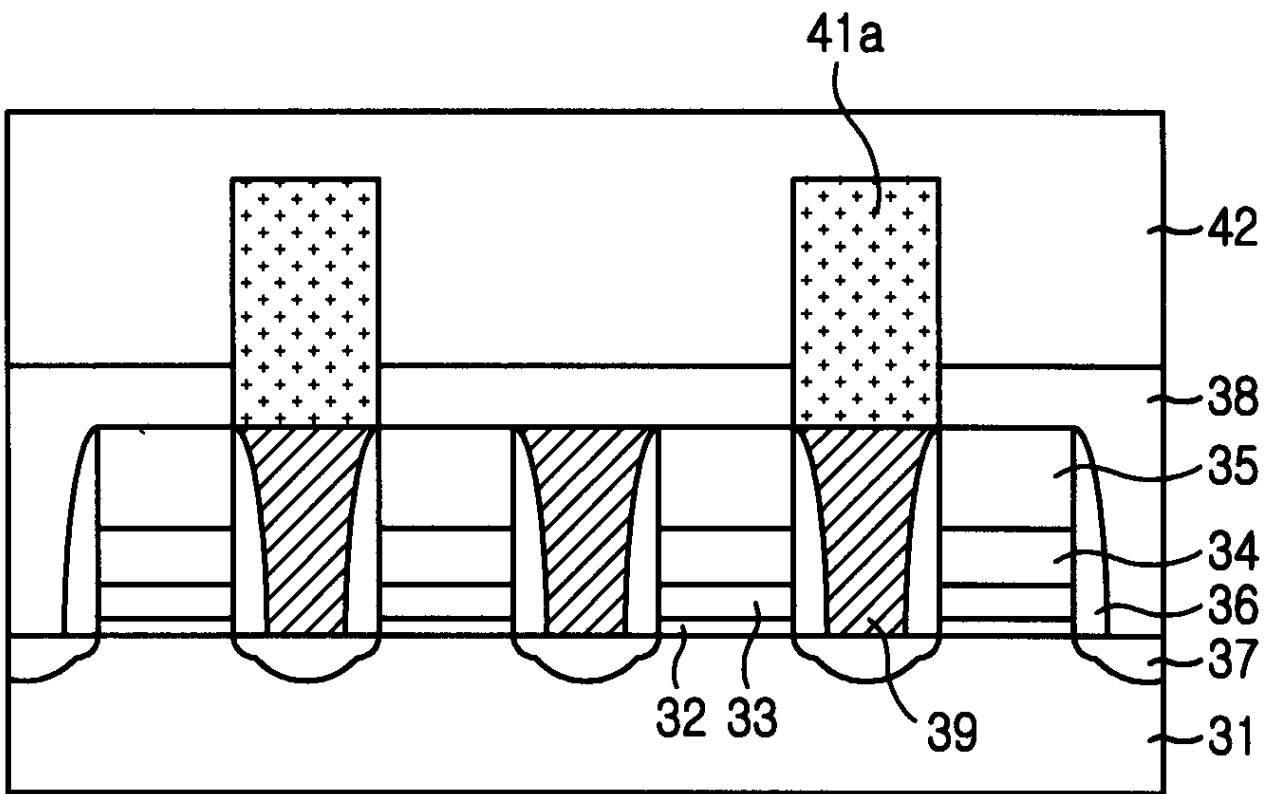

5c

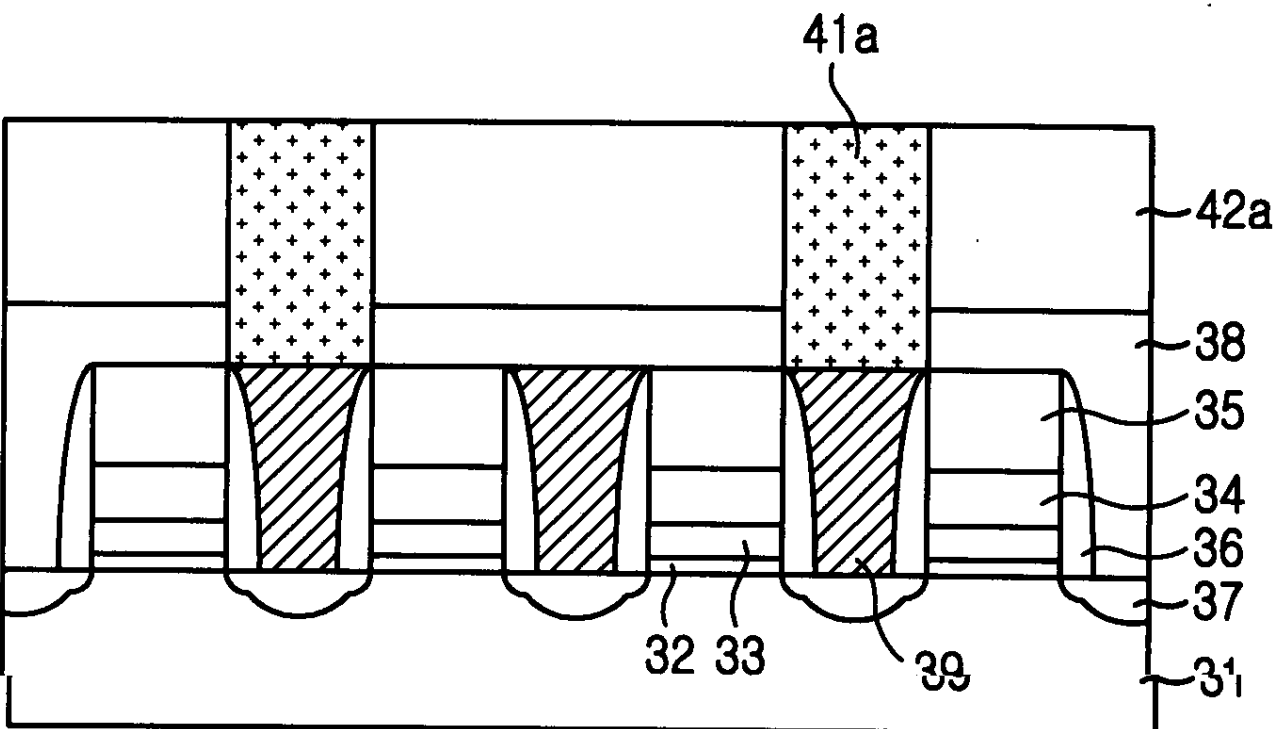

5d

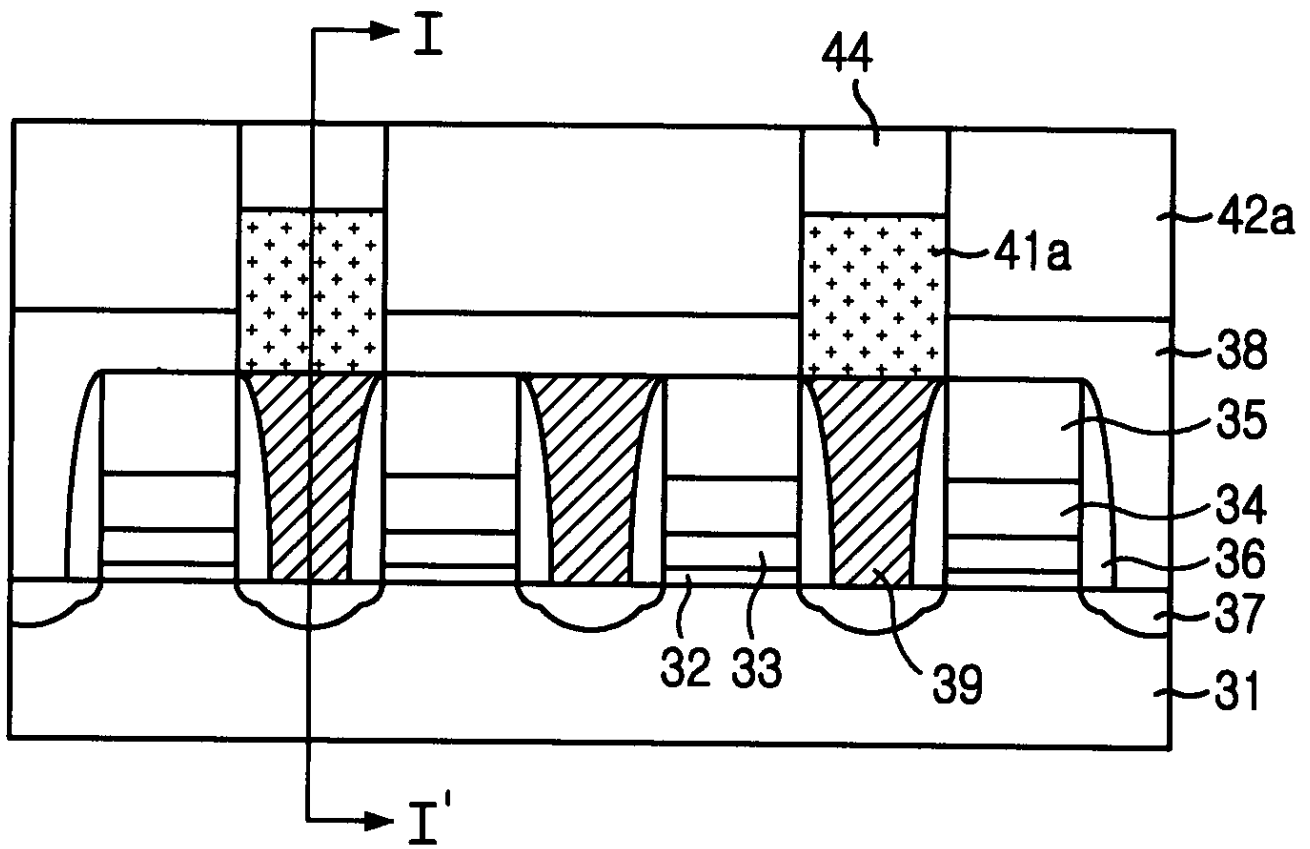

6a

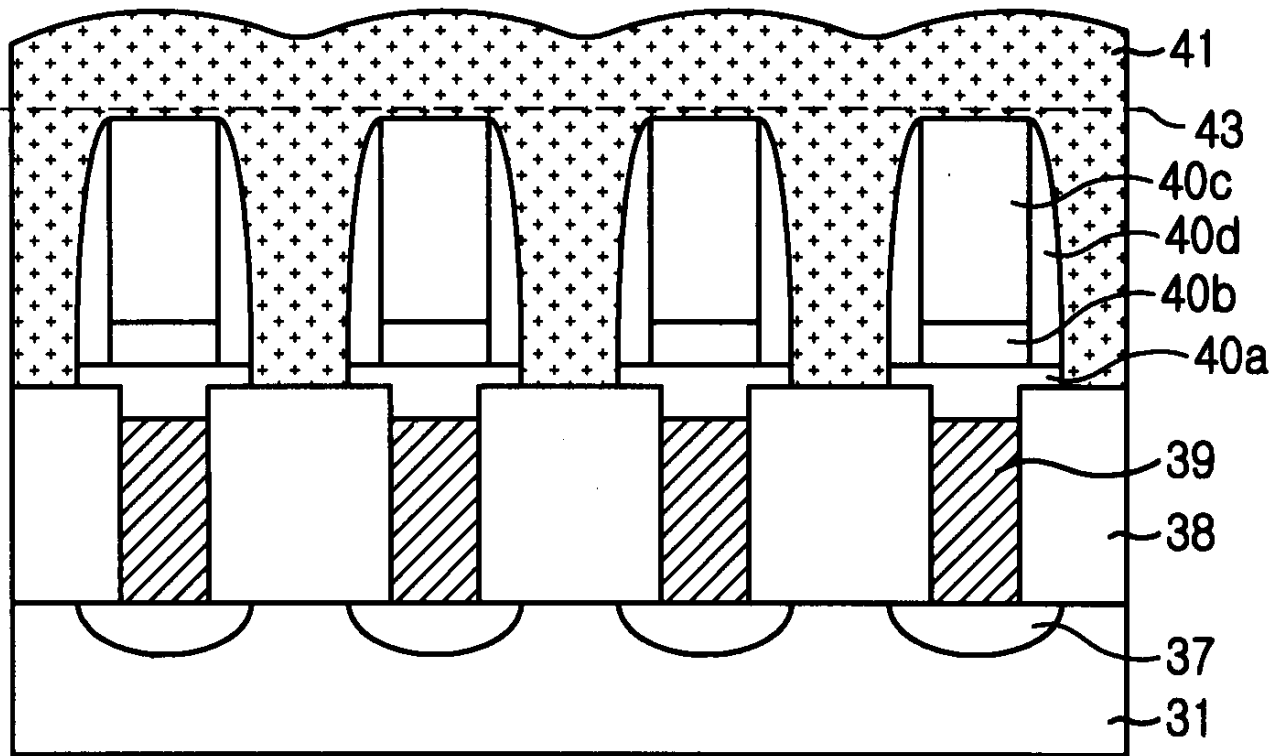

6b

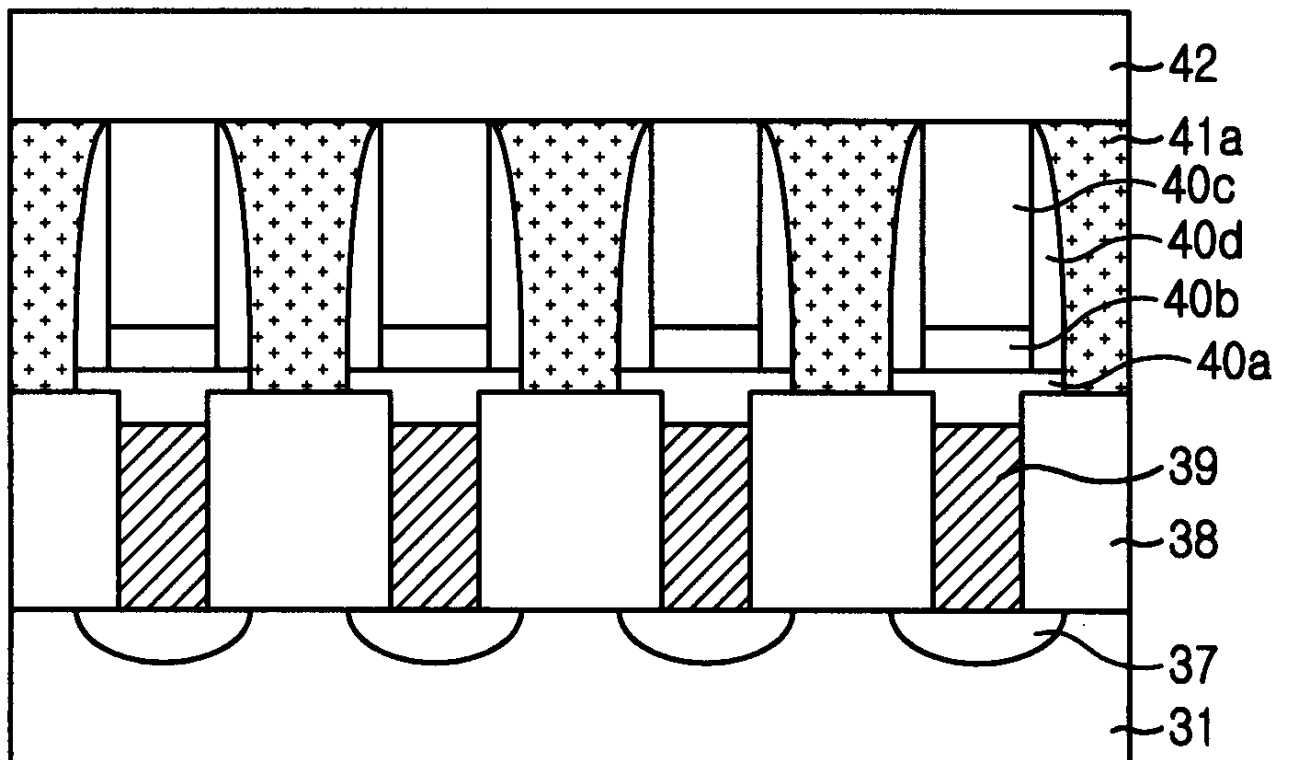

6c

