

H. A. HURD.
SHAFT COUPLING.

Fig 1

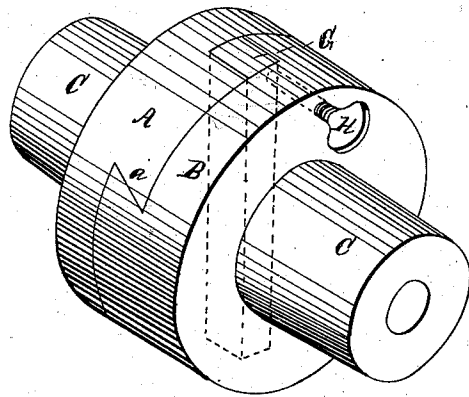

Fig 2.

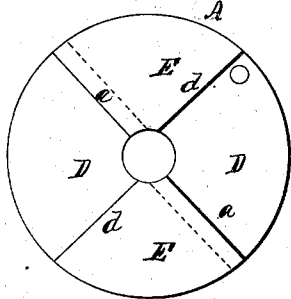

Fig 3

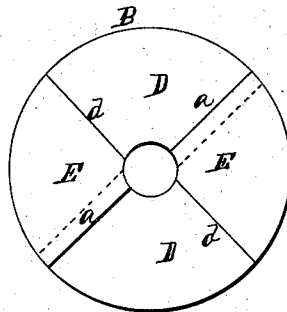
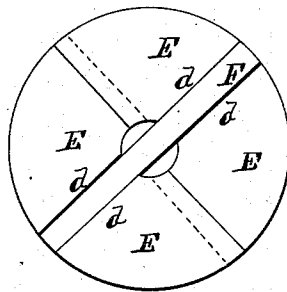

Fig 4



Witnesses.

Alvan N. Huntington
A. J. Tolbert

Inventor.

Hiram A. Hurd.

By his Attorney.

Wm. C. Carr

United States Patent Office.

HIRAM A. HURD, OF SEYMOUR, CONNECTICUT.

Letters Patent No. 67,878, dated August 20, 1867.

IMPROVEMENT IN SHAFT-COUPLING.

The Schedule referred to in these Letters Patent and making part of the same.

TO ALL WHOM IT MAY CONCERN:

Be it known that I, HIRAM A. HURD, of Seymour, in the county of New Haven, and State of Connecticut, have invented a new Improvement in Machinery-Coupling; and I do hereby declare the following, when taken in connection with the accompanying drawings and the letters of reference marked thereon, to be a full, clear, and exact description of the same, and which said drawings constitute part of this specification, and represent, in—

Figure 1, perspective view.

Figures 2 and 3, inside ends of the two parts.

Figure 4, a section cutting through upon the face of one of the parts.

This invention relates to an improvement in couplings for connecting shafting and other similar mechanical uses, and consists in the peculiar formation of the two parts whereby they are easily locked together or separated, and without the employment of bolt or screw; and in order to the better understanding of my invention, as well as to enable others to construct the same, I will proceed to a description thereof as illustrated in the accompanying drawings.

A is the one part, B is the other part, each provided with a neck, C, into which the shaft to be coupled is inserted and secured in the usual manner. Upon the face of each of the two parts a dove-tail, *a*, is formed, as seen in figs. 1, 2, and 3, leaving recesses D and projections E, the sides *d* of which are at right angles to the face of the coupling, and the same side *d* of the projection in each is out from the centre but nearly parallel with each other, as seen in figs. 2, 3, and 4, so that the projection of the one may be set into the recess of the other and turned so that the dove-tail of the one will lock in the dove-tail of the other, as seen in figs. 1 and 4, and when so turned the sides *d* form an open passage, F, through the coupling, as seen in fig. 4, and into this opening a key, G, fig. 1, is inserted, either passing through, or may be a key from each side which locks the two parts, the dove-tail thus preventing their separation. If it should be deemed advisable to secure the key in the coupling, a screw, H, or other device, may be introduced for that purpose. To separate the coupling remove the key and the lock is released and the two parts easily separated.

I do not broadly claim securing the two parts by coupling together by a key passing therethrough, as such arrangement is seen in the patent of Samuel Hull, May 29, 1860, but in that it will be observed that the key is formed to fit a corresponding dove-tailed groove in each of the two parts of the coupling, so that dependence rests entirely upon the key to prevent the separation of the coupling laterally; neither do I broadly claim constructing a coupling with a projection upon part to set into a corresponding recess in the other part, as such is not new.

Having thus fully described my invention, what I claim as new and useful, and desire to secure by Letters Patent, is—

A coupling on the face of each part of which are formed projections E E and recesses D D, one side, *a*, of each of the projections of a dove-tail form, the other side, *d*, at right angles; the two parts set together and secured by key G, inserted between the right angles or parallel sides, substantially as herein set forth.

HIRAM A. HURD.

Witnesses:

A. J. TIBBITS,

JOHN H. SHUMWAY.