



(22) Date de dépôt/Filing Date: 2013/10/09

(41) Mise à la disp. pub./Open to Public Insp.: 2014/04/16

(30) Priorité/Priority: 2012/10/16 (EP12188666.7)

(51) Cl.Int./Int.Cl. *B01D 53/14* (2006.01),
B01D 53/50 (2006.01), *B01D 53/62* (2006.01)

(71) Demandeur/Applicant:
ALSTOM TECHNOLOGY LTD, CH

(72) Inventeurs/Inventors:
STALLMANN, OLAF, DE;
HEINZ, GERHARD, DE;
KOSS, PETER ULRICH, CH

(74) Agent: SMART & BIGGAR

(54) Titre : DESULFURATION DANS UN SYSTEME A CYCLE DE CALCIUM REGENERATEUR

(54) Title: DESULFURIZATION IN A REGENERATIVE CALCIUM CYCLE SYSTEM

(57) **Abrégé/Abstract:**

The present invention relates to a method and system for combustion of a fuel and treatment of the resulting flue gas, said method comprising: combusting a fuel with air or oxygen to produce a hot flue gas stream containing at least carbon dioxide (CO₂) and sulfur dioxide (SO₂), bringing the flue gas stream into contact with solid calcium oxide (CaO) in a carbonation reactor (120) operating at a temperature at which CO₂ in the flue gas reacts with CaO to form solid calcium carbonate (CaCO₃), heating CaCO₃ formed in the carbonation reactor in a calcination reactor (130) operating at a temperature at which CaCO₃ is converted to CaO and CO₂, whereby said heating is at least partially effected by indirect heat exchange with the hot flue gas stream from the combustion, and recirculating CaO formed in the calcination reactor back to the carbonation reactor, characterized in that the flue gas used for indirect heat exchange in the calcination reactor is subsequently subjected to dry desulfurization in a dry desulfurizer before it is brought into contact with CaO in the carbonation reactor.



ABSTRACT

The present invention relates to a method and system for combustion of a fuel and treatment of the resulting flue gas, said method comprising:

5 combusting a fuel with air or oxygen to produce a hot flue gas stream containing at least carbon dioxide (CO_2) and sulfur dioxide (SO_2), bringing the flue gas stream into contact with solid calcium oxide (CaO) in a carbonation reactor (120) operating at a temperature at which CO_2 in the flue gas reacts with CaO to form solid calcium carbonate (CaCO_3), heating CaCO_3 formed in

10 the carbonation reactor in a calcination reactor (130) operating at a temperature at which CaCO_3 is converted to CaO and CO_2 , whereby said heating is at least partially effected by indirect heat exchange with the hot flue gas stream from the combustion, and recirculating CaO formed in the calcination reactor back to the carbonation reactor, characterized in that the

15 flue gas used for indirect heat exchange in the calcination reactor is subsequently subjected to dry desulfurization in a dry desulfurizer before it is brought into contact with CaO in the carbonation reactor.

20 Figure 1 to be published together with Abstract

DESULFURIZATION IN A REGENERATIVE CALCIUM CYCLE SYSTEM

Field of the Invention

The present invention relates to systems and methods for capturing carbon dioxide from flue gas using regenerative calcium cycle systems.

5

Background of the Invention

In the combustion of fuel, for example coal, oil, peat, waste, natural gas, etc in a combustion plant, such as power plant, a process gas comprising among other components, carbon dioxide in large amounts. The negative effects of carbon dioxide on climate change are well known and there is a strong demand on reducing the emissions of carbon dioxide generated. This demand applies not only to the different power plants as above but also other situations and other industries where CO₂ is generated in their processes or by their energy consumption, for example in the cement industry and steel industry. There are a lot of different methods and arrangements for reducing the carbon dioxide emission.

10
15

However, common for the methods is that the separation of carbon dioxide from exhaust gases generated in the different industrial plants as above are energy demanding and costly and there is a need to find more efficient ways.

20

In one of the methods for capturing CO₂, known as regenerative calcium cycle (RCC), the separation of CO₂ from the flue gas may take place by capturing via a combined carbonation and calcination cycle. In such methods, lime (CaO) may be used as a sorbent agent for the carbon dioxide, forming carbonate of calcium (CaCO₃) during the so called carbonation reaction. The formed CaCO₃ is subsequently regenerated by heating, whereby the so called calcination reaction produces carbon dioxide and CaO.

25

A method and system for a regenerative calcium cycle (RCC) is described in US 6, 737, 031. More specifically, a method for capturing sulfur dioxide (SO₂) and carbon dioxide (CO₂) is described therein. For capturing of the carbon dioxide the method comprises steps wherein the carbon dioxide

30

present in the flue gases is captured by carbonization in the hearth and then released by decarbonization and the carbon dioxide released is transferred for further treatment or storage.

Although an RCC system, e.g. as described in US 6, 737, 031, can be made more energy efficient than other available systems for carbon capture and storage, it still carries a negative impact on the overall efficiency of the power plant. There is a need for improved RCC systems that further reduce the impact on the overall efficiency of the power plant.

10 Summary of the Invention

The present invention relates to improvements in integrated methods and systems for combustion and CO₂ capture using a regenerative calcium cycle (RCC). More particularly, the present invention is contemplated for implementation in a power plant.

15 According to an aspect illustrated herein, there is provided a method for combustion of a fuel and treatment of the resulting flue gas, said method comprising:

combusting a fuel with air or oxygen to produce a hot flue gas stream containing at least carbon dioxide (CO₂) and sulfur dioxide (SO₂),

20 bringing the flue gas stream into contact with solid calcium oxide (CaO) in a carbonation reactor (120) operating at a temperature at which CO₂ in the flue gas reacts with CaO to form solid calcium carbonate (CaCO₃),

heating CaCO₃ formed in the carbonation reactor in a calcination reactor (130) operating at a temperature at which CaCO₃ is converted to CaO and CO₂, whereby said heating is at least partially effected by indirect heat exchange with the hot flue gas stream from the combustion, and

25 recirculating CaO formed in the calcination reactor back to the carbonation reactor, characterized in that

30 the flue gas used for indirect heat exchange in the calcination reactor is subsequently subjected to dry desulfurization before it is brought into contact with CaO in the carbonation reactor.

Desulfurization in integrated methods and systems for combustion and CO₂ capture using a regenerative calcium cycle (RCC) has previously been performed by CaO adsorption of SO₂ in the carbonation reactor concurrently with the CaO adsorption of CO₂. Although such coadsorption of SO₂ and CO₂ provides efficient removal of SO₂ from the flue gas, there are also some drawbacks. SO₂ reacts with CaO to form CaSO₄ (gypsum). CaSO₄ is heat stable and does not decompose along with the CaCO₃ in the calcination reactor. As CaSO₄ is accumulated in the RCC adsorbent circulation, the adsorption capacity of the system is reduced, and the recirculation rate of the RCC must be increased.

It has now been found that desulfurization of the flue gas may advantageously be performed before the flue gas is brought into contact with the CaO in the carbonation reactor. This arrangement allows a drastic reduction of the required recirculation rate in the RCC system. Desulfurization is most commonly done using, e.g., limestone in a wet scrubber process. However, it has been found that a number of beneficial synergistic effects can be achieved by performing the desulfurization process at higher temperature than those used in conventional wet scrubber processes. More specifically, it has been found that in the methods and systems of the present disclosure, desulfurization should preferably be performed at a temperature in the range of 200 °C to 700 °C. This can be achieved by the use of a dry desulfurization process (also referred to herein as DFGD). The dry desulfurization process may for example comprise bringing the flue gas into contact with solid calcium oxide (CaO) at a temperature whereby SO₂ in the flue gas reacts with CaO to form solid calcium sulfate (CaSO₄) and the subsequent removal of the formed solid calcium sulfate using a suitable dedusting technique, for example using high temperature filter elements (metal or ceramic based) and/or electrostatic precipitation (ESP). Additionally, it has been found that as the CaO for the dry desulfurization process, may advantageously be employed spent CaO recovered from, for example, the flue gas filters of the system. This of course reduces the overall CaO/CaCO₃ consumption of the method/system as well as the total amount of waste.

According to some embodiments, the desulfurization is performed at a temperature in the range of 200 °C to 700 °C.

According to some embodiments, the desulfurization is performed at a temperature in the range of 200 °C to 400 °C, preferably in the range of 250
5 °C to 350 °C.

According to some embodiments, the desulfurization is performed at a temperature in the range of 500 °C to 700 °C, preferably in the range of 550 °C to 650 °C.

According to some embodiments, the desulfurization comprises
10 bringing the flue gas into contact with solid calcium oxide (CaO) at a temperature whereby SO₂ in the flue gas reacts with CaO to form solid calcium sulfate (CaSO₄).

Desulfurization may simply be performed by injection of CaO into the flue gas stream by means of a dedicated CaO injection equipment. Injection
15 may be performed into or downstream of a combustion zone of the furnace used for heating of the calcination reactor.

According to some embodiments the CaO is injected into the combustion zone of the furnace used for heating of the calcination reactor.

According to some embodiments the CaO is injected into the flue gas
20 stream downstream of a combustion zone of the furnace used for heating of the calcination reactor.

According to some embodiments the CaO is injected into the flue gas stream in a dedicated desulfurizer arranged downstream of a combustion zone of the furnace used for heating of the calcination reactor.

25 Alternatively, desulfurization may be performed by injection of the flue gas into a circulating or bubbling fluidized bed of CaO, separate from the calcination reactor.

According to some embodiments, the method further comprises the step of removing dust from the desulfurized flue gas before it is brought into
30 contact with CaO in the carbonation reactor. This dust removal step may serve to at least partially remove solid CaSO₄ present in the flue gas after the dry desulfurization.

According to some embodiments, the CaO used for desulfurization of the flue gas at least partially comprises CaO recovered from the CO₂ rich flue gas formed in the calcination reactor, from the flue gas stream downstream of the carbonation reactor and/or from CaO formed in the calcination reactor.

5 According to some embodiments, the temperature in the carbonation reactor is in the range of 550 to 750 °C, preferably about 650 °C.

According to some embodiments, the temperature in the calcination reactor is in the range of 800 to 1100 °C, preferably about 900 °C.

10 According to another aspect illustrated herein, there is provided a system (100) for combustion of a fuel and treatment of the resulting flue gas, said system comprising:

a furnace (101)

15 a carbonation reactor (120)

a calcination reactor (130)

a dry desulfurizer (110)

20 wherein the furnace (101) is operative for combusting a fuel with air or oxygen to produce a hot flue gas stream containing at least carbon dioxide (CO₂) and sulfur dioxide (SO₂),

the carbonation reactor (120) is operative for bringing the flue gas stream into contact with solid calcium oxide (CaO) at a temperature at which CO₂ in the flue gas reacts with CaO to form solid calcium carbonate (CaCO₃),

25 the calcination reactor (130) is operative for heating CaCO₃ formed in the carbonation reactor at a temperature at which CaCO₃ is converted to CaO and CO₂,

the calcination reactor (130) comprises means for indirect heating (104) whereby said heating of CaCO₃ is at least partially effected by indirect 30 heat exchange with the hot flue gas stream from the combustion, and

wherein

the dry desulfurizer (110) is operative for subjecting the flue gas stream to dry desulfurization before it is brought into contact with CaO in the carbonation reactor (120).

The system may further comprise a solids recirculation system, operative for forwarding CaCO₃ from the carbonation reactor to the calcination reactor and for forwarding CaO from the calcination reactor to the carbonation reactor. The system may further also comprise a fresh CaO and/or CaCO₃ supply system for replenishing CaO and/or CaCO₃ lost throughout the process.

10 According to some embodiments, the dry desulfurizer is configured to operate at a temperature in the range of 200 °C to 700 °C.

According to some embodiments, the dry desulfurizer is operative for bringing the flue gas into contact with solid calcium oxide (CaO) at a temperature whereby SO₂ in the flue gas reacts with CaO to form solid calcium sulfate (CaSO₄).

The dry desulfurizer may comprise a dedicated CaO injection equipment operative for injection of CaO into the flue gas stream. The CaO injection equipment may be arranged in or downstream of a combustion zone of the furnace used for heating of the calcination reactor.

20 According to some embodiments the CaO injection equipment is arranged in the combustion zone of the furnace used for heating of the calcination reactor.

According to some embodiments the CaO injection equipment is arranged in the flue gas duct (105) downstream of a combustion zone of the furnace used for heating of the calcination reactor.

25 According to some embodiments the CaO injection equipment is arranged in a dedicated reactor arranged downstream of a combustion zone of the furnace used for heating of the calcination reactor.

Alternatively, the desulfurizer may comprise a dedicated circulating or bubbling fluidized bed reactor, operative for bringing the flue gas into contact with a circulating or bubbling fluidized bed of CaO at a temperature whereby SO₂ in the flue gas reacts with CaO to form solid calcium sulfate (CaSO₄).

According to some embodiments, the dry desulfurizer is in fluid connection with and configured to receive CaO recovered from a dust removal unit (132) operative for removing CaO from the CO₂ rich flue gas formed in the calcination reactor.

5 According to some embodiments, the dry desulfurizer is in fluid connection with and configured to receive CaO recovered from a dust removal unit (124) operative for removing CaO from the flue gas stream downstream of the carbonation reactor.

10 According to some embodiments, the dry desulfurizer is in fluid connection with and configured to receive CaO formed in the calcination reactor.

According to some embodiments, the system further comprises a dust removal unit (115) operative for removal of dust from the desulfurized flue gas before it is brought into contact with CaO in the carbonation reactor (120).

15 This dust removal unit may serve to at least partially remove solid CaSO₄ present in the flue gas downstream of the dry desulfurizer.

The method or system according to any one of the aspects of the invention may be a regenerative calcium cycle (RCC) method or system or an integrated combustion and regenerative calcium cycle (RCC) method or
20 system. By the term "integrated combustion and regenerative calcium cycle (RCC) method or system" as used herein, is meant a system for combustion of a fuel, e.g. in a power plant, wherein heat from the flue gases of the combustion is used for heating the calcination reactor.

The method or system according to any one of the aspects of the
25 invention may be operated as a standalone integrated power generation unit, wherein the heat generated during combustion in the RCC system is used for power generation. The method or system according to any one of the aspects of the invention may also be operated as a CO₂ capture system for a separate power generation unit (e.g. a boiler system), wherein flue gas
30 generated by the separate power generation unit is combined with flue gas generated during combustion in the RCC system.

According to some embodiments, the carbonation reactor and/or calcination reactor of the method or system according to any one of the aspects of the invention may comprise is/are both of the fluidized bed type. According to some embodiments, the carbonation reactor and calcination
5 reactor are both of the circulating fluidized bed type. According to some embodiments, the carbonation reactor is of the circulating fluidized bed type and the calcination reactor is of the bubbling fluidized bed type.

The above described and other features are exemplified by the following figures and detailed description.

10

Brief description of the Drawings

Referring now to the drawings, which are exemplary embodiments, and wherein the like elements are numbered alike:

Figure 1 schematically depicts an integrated combustion and RCC
15 system.

Figure 2 schematically depicts an integrated combustion and RCC system with dry flue gas desulfurization.

Description of preferred embodiments

20 An embodiment of the system of the invention is further illustrated in figure 1.

Herein, the system (100) is implemented in connection with a combustion process unit comprising a furnace (101) wherein carbon dioxide in the generated exhaust gas is to be captured by the RCC system. The
25 system is heated by indirect heating of the calcination reactor (130) by the furnace (101) being fed with fuel via pipe (102) and air and/or oxygen via duct (103).

The flue gas generated by the combustion in the furnace (101) comprising, among other components, carbon dioxide and sulfur dioxide is
30 forwarded via duct (105) to the dry flue gas desulfurizer (DFGD) (110) operative for reducing the SO₂ content of the flue gas. The DFGD (110) will be described more in detail below.

The flue gas with a reduced content of SO₂ is forwarded from the DFGD (110) to a dust removal unit (115) operative for removal of dust from the desulfurized flue gas whereby solids, e.g. solid CaSO₄, present in the flue gas is at least partially removed before introduction of the flue gas into the carbonation reactor (120). The dust removal unit (115) may for example
5 comprise an electrostatic precipitation (ESP) device or any other suitable dust removal device. Besides solid CaSO₄, the flue gas leaving the DFGD (110) may also comprise fly ash which is also at least partially removed by the dust removal unit (115). The dust removal unit (115) may in some embodiments
10 comprise a staged dedusting system allowing for separation of CaSO₄ and fly ash. This arrangement yields higher quality CaSO₄ and ash by-products with improved commercial viability.

Optionally, the exhaust gas may be further conditioned in a unit for conditioning the flue gas (not shown) before its introduction into the
15 carbonation reactor (120). The optional conditioning may, for example, include treatment of the exhaust gas by removal of NO_x gases (DeNO_x).

The flue gas from the dust removal unit (115) (and optional further flue gas conditioning unit) is pressurized by passing the fan unit (116) and preheated by the heat exchanger (117) before introduction to the carbonation
20 reactor (120), the reactor for capturing carbon dioxide. The carbonation reactor (120) may also be denoted "the carbonator" and the reaction "carbonation".

The exhaust gas is preferably pressurized to a pressure in the range of 50 mbarg to 400 mbarg, preferably about 100 mbarg, and heated to a
25 temperature in the range of 300 °C to 600 °C for an optimized sorption.

The main reaction taking place in the carbonation reactor corresponds to $\text{CaO} + \text{CO}_2 \rightarrow \text{CaCO}_3$. The reaction is exothermic and takes place at temperature in the range of 550 to 750 °C. The carbonation reactor is typically operating at a temperature in the range of 600 °C to 700 °C,
30 preferably at about 650 °C.

The exhaust gases with a reduced content of carbon dioxide CO₂ forwarded from the carbonation reactor (120) via duct (121) may optionally be

cooled in multiple steps, e.g. in heat exchangers (122), (117) and (123). The heat recovered in these heat exchangers may for example (as shown for heat exchanger (117) in figure 1) be employed for preheating of exhaust gas which will be introduced in the carbonation reactor (120) or in other heat

5 exchangers.

Following the optional multiple step cooling, the flue gas is subjected to dust removal in a dust removal unit (124) (e.g. comprising an electrostatic precipitation (ESP) device or any other suitable dust removal device). In the dust removal unit (124) CaO and CaCO₃ dust carried along with the flue gas
10 from the carbonation reactor is separated from the flue gas before the flue gas is forwarded to stack (128) for release to the atmosphere.

In the embodiment of figure 1 the carbonation reactor (120) and calcination reactor (130) are both of the circulating fluidized bed type. A bed of solid particles are fluidized by a gas stream passing through the bed. In the
15 carbonation reactor (120), fluidization is effected by the gas steam forwarded from the DFGD (110) and dust removal unit (115) via fan unit (116). In the calcination reactor (130), fluidization is effected by a portion of the CO₂ rich flue gas stream recirculated to the calcination reactor (130) via duct (134) and preferably pressurized in a fan unit (135). Solids present in the gas stream
20 leaving the bed are captured by a cyclone unit.

In an alternative embodiment of the system (not shown), the circulating fluidized bed calcination reactor has been replaced by a bubbling bed calcination reactor. A bubbling bed calcination reactor can be advantageous since the attrition rate of the CaO in such systems is much lower due to the
25 lower solid velocity.

The system of the invention using the regenerative calcium cycle comprises circulation of solid material between the carbonation reactor (120) and the calcination reactor (130).

The system may further comprise a solids recirculation system,
30 operative for forwarding CaCO₃ from the carbonation reactor to the calcination reactor and for forwarding CaO from the calcination reactor to the carbonation reactor.

From the carbonation reactor (120) solid material being rich in calcium carbonate CaCO_3 , but also containing a certain amount of lime, CaO , as well as other components, is transferred to the calcination reactor (130) via pipe (125). The stream of solid material is split for different destinations of the solid material, a first part of the solid material stream in pipe (125) is recirculated back to the carbonation reactor (120) via pipe (125a). A second part of the solid material is transferred, via duct (125b), to the calcination reactor (130).

The system may further also comprise a fresh CaO and/or CaCO_3 supply system for replenishing CaO and/or CaCO_3 lost throughout the process.

In the calcination reactor (130) the calcium carbonate CaCO_3 is heated to effect decomposition of CaCO_3 into lime CaO and carbon dioxide CO_2 . The calcination reactor (130) is also called "the calciner" and the process also called "calcination". The main reaction of the calcination reactor corresponds to $\text{CaCO}_3 \rightarrow \text{CaO} + \text{CO}_2$. The reaction is endothermic and is performed at a temperature in the range of 800 °C to 1100 °C, typically at temperature about 900 °C. The calcination reactor (130) is heated by indirect heating, via the furnace (101). This arrangement allows use of fuels of varying quality. Depending on the fuel quality, more or less oxygen may be supplied to the furnace. If fuel of high quality is used for heating the apparatus, the furnace may be fed with air, if lower quality the air may be mixed with oxygen, or be pure oxygen. The carbon dioxide rich flue gas generated by the furnace (101) for indirect heating of the calcination reactor may, in addition to CO_2 , typically comprise contaminants in the form of, for example sulfur oxides SO_x (e.g. SO_2), dust particles, hydrochloric acid, HCl , nitrous oxides NO_x , and heavy metals including mercury, Hg . If the concentration of gases like oxygen (O_2), nitrogen (N_2) etc, most often introduced during the carbonation, is high a separation step may be required in the system. Otherwise, further treatment of the carbon dioxide rich flue gas may be performed in compression and/or drying systems.

The terms "indirect" or "indirectly" as used herein in connection with heat exchange between two media, such as heating, cooling or chilling,

denotes that the heat exchange occurs without mixing the two medias together. By the term "indirect heat exchanger" as used herein, is meant a heat exchanger configured for indirect heat exchange. The heat exchanger may be adapted for gases (gas/gas), liquids (liquid/liquid), solids (solid/solid) or any combination thereof (e.g. gas/liquid). The heat exchanger may for
5 example be of the shell and tube type. Suitable types and dimensions of heat exchangers are readily identified by the person skilled in the art.

In the embodiment of figure 1, the furnace (101) is arranged in direct connection with the calcination reactor (130) such that the hot flue gas formed
10 during combustion in the furnace (101) is directed into a an indirect heating arrangement (104) of the calcination reactor (130). The indirect heating arrangement (104) may for example comprise heat transfer tubes arranged to transfer heat from the hot flue gas flowing through the tubes to the fluidized bed inside of the calcination reactor.

15 Solid material comprising mainly lime, CaO, produced by the decomposition of the calcium carbonate is transferred from the calcination reactor (130) via pipe (135) to the carbonation reactor (120). Pipe (135) is split into pipe (135a), through which first portion of the solid stream is recirculated back to the calcination reactor (130), and pipe (135b), through
20 which a second portion of the solid stream is transferred to the carbonation reactor (120).

A heat exchanger (137) is arranged between the carbonation reactor (120) and the calcination reactor (130) and is operative for preheating the solid material transferred from the carbonation reactor via pipe (125b) using
25 the heat of the solid material transferred from the calcination reactor via pipe (135b). The heat exchanger (137) may for example be a cross heat exchanger transferring heat from the solid material of the calcination reactor with the solid material of the carbonation reactor (solid/solid heat exchanger).

The CO₂ rich exhaust gas generated in the calcination (130) reactor is
30 separated from solid material, e.g. using cyclones or other methods for separating solid material from a gas stream. The solid material is recirculated to the fluidized bed via duct (135) and (135a). The CO₂ enriched gas is

transferred from the calcination reactor via duct (131) for further processing, e.g. including heat recovery and particulate removal.

The dust generated during the calcination process in the calcination reactor (130) may be extracted and removed from the recirculation loop for further processing in a dust removal unit (132), for example comprising an electrostatic precipitator (ESP). Further, the heat of the CO₂ rich gas may be recovered by a heat exchanger (133) before the gas transferred for optional further processing in a gas processing unit (GPU) (140), such as compression, storage, etc.

After the dust removal, a portion of the carbon dioxide rich exhaust gas may be recirculated to the calcination reactor (130) via duct (134). The exhaust gas is preferably pressurized in a fan (135) and preheated by the hot exhaust gas in duct (131) using a gas/gas heat exchanger (136) before being reintroduced into the calcination reactor (130), via duct (134).

Optionally, the carbon dioxide rich exhaust gas, or at least a portion thereof, may be combined, via duct (138), with gas in duct (105), recirculating the hot exhaust gas used for the indirect heating of the calcination reactor to the carbonation reactor (120).

Another option is to introduce a portion of, the carbon dioxide enriched gas, via duct 139, to the duct (102) feeding the furnace (101) with air and/or oxygen.

The hot exhaust gas comprising carbon dioxide CO₂ generated for the indirect heating the calcination reactor (130) is forwarded to the carbonation reactor (120), via duct (105).

Heat from the hot exhaust gas generated for the indirect heating of the calcination reactor may optionally be recovered by heat exchanger (106) (gas/gas heater).

As mentioned above, the flue gas generated by the combustion in the furnace (101) and comprising, among other components, carbon dioxide and sulfur dioxide is forwarded via duct (105) to the dry flue gas desulfurizer (110) (DFGD) operative for reducing the SO₂ content of the flue gas. The dry flue gas desulfurizer may simply comprise a dedicated CaO injection equipment

operative for injection of CaO into the flue gas stream. The CaO injection equipment may be arranged in or downstream of a combustion zone of the furnace (101) used for heating of the calcination reactor (130). According to some embodiments the CaO injection equipment is arranged in the

5 combustion zone of the furnace (101). According to some embodiments the CaO injection equipment is arranged in the flue gas duct (105) downstream of a combustion zone of the furnace (101). According to some embodiments the CaO injection equipment is arranged in a dedicated reactor arranged downstream of a combustion zone of the furnace used for heating of the

10 calcination reactor. In the embodiment of figure 1, the CaO injection equipment is arranged in a dedicated reactor, DFGD (110), arranged downstream of a combustion zone of the furnace (101).

Alternatively, the desulfurizer may comprise a dedicated circulating or bubbling fluidized bed reactor, operative for bringing the flue gas into contact

15 with a circulating or bubbling fluidized bed of CaO at a temperature whereby SO₂ in the flue gas reacts with CaO to form solid calcium sulfate (CaSO₄).

In the DFGD (110), the flue gas is contacted with solid calcium oxide (CaO) at a temperature in the range of in the range of 200 °C to 700 °C. At these temperatures, CaO reacts with SO₂ present in the flue gas to form solid

20 calcium sulfate (CaSO₄). In some embodiments, the desulfurization is performed at a temperature in the range of 200 °C to 400 °C, preferably in the range of 250 °C to 350 °C. In other embodiments, the desulfurization is performed at a temperature in the range of 500 °C to 700 °C, preferably in the range of 550 °C to 650 °C.

25 The solid calcium oxide (CaO) used for the desulfurization of the flue gas in the DFGD (110) at least partially comprises CaO recovered from the CO₂ rich flue gas formed in the calcination reactor (130), from the flue gas stream downstream of the carbonation reactor (120) and/or from CaO formed in the calcination reactor, e.g. from the carbonation reactor CaO feed stream.

30 The CaO used in the DFGD (110) may for example comprise CaO collected from the dust removal unit (132) operative for removing dust from the CO₂ rich flue gas stream leaving the calcination reactor (130), forwarded to the

DFGD via duct (151). The CaO used in the DFGD (110) may also comprise CaO collected from the dust removal unit (124) operative for removing dust from the flue gas stream leaving the carbonation reactor (120), forwarded to the DFGD via duct (152). The CaO used in the DFGD may also comprise
5 CaO drawn off from the carbonation reactor CaO feed stream (135b), forwarded to the DFGD via duct (153), optionally with cooling of the CaO in heat exchanger (154). In an alternative embodiment, the CaO, or at least a portion thereof, is directed to the furnace (101), via the duct (155).

10 An embodiment of the system of the invention is further illustrated in figure 2. The embodiment of figure 2 is mainly identical to the embodiment of figure 1 with the exception that in figure 2, the flue gas forwarded via duct (105) to the dry flue gas desulfurizer (DFGD) (110) is subjected to heat exchange in heat exchanger (117) with the pressurized flue gas being
15 forwarded from the fan unit (116) towards the carbonation reactor (120). This configuration may further decrease the overall impact of the RCC CO₂ capture system on the overall efficiency of the power plant.

As used herein, the term "desulfurization" refers to a process for the (at least partial) removal of sulfur dioxide, SO₂, from a flue gas stream. A
20 "desulfurizer" refers to an apparatus dedicated for the removal of SO₂ from a flue gas stream.

Advantages obtained by the present invention include:

The present invention reduces the impact of the RCC CO₂ capture
25 system on the overall efficiency of the power plant.

The present invention prevents accumulation of CaSO₄ in the RCC adsorbent circulation which may otherwise cause the adsorption capacity of the system to become reduced.

The inventive arrangement allows a drastic reduction of the required
30 recirculation rate in the RCC system.

Desulfurization at a temperature in the range of 200 °C to 700 °C reduces the need for cooling and reheating of the flue gas for desulfurization.

The invention provides for using spent CaO recovered from, for example, the flue gas filters of the system for desulfurization. This reduces the overall CaO/CaCO₃ consumption of the method/system as well as the total amount of waste.

5 The quality of fuel for heating the system may vary widely as the heating is performed indirectly into the calcination reactor, the calciner.

The CO₂ product captured is of high purity as no direct entrainment of impurities into the CO₂ product occur. Impurities and contaminants are mainly adsorbed by the CaO.

10 While the invention has been described with reference to various exemplary embodiments, it will be understood by those skilled in the art that various changes may be made and equivalents may be substituted for elements thereof without departing from the scope of the invention. In addition, many modifications may be made to adapt a particular situation or
15 material to the teachings of the invention without departing from the essential scope thereof. Therefore, it is intended that the invention not be limited to the particular embodiment disclosed as the best mode contemplated for carrying out this invention, but that the invention will include all embodiments falling within the scope of the appended claims.

20

CLAIMS

1. A method for combustion of a fuel and treatment of the resulting flue gas, said method comprising:

- 5 combusting a fuel with air or oxygen to produce a hot flue gas stream containing at least carbon dioxide (CO₂) and sulfur dioxide (SO₂),
 bringing the flue gas stream into contact with solid calcium oxide (CaO) in a carbonation reactor (120) operating at a temperature at which CO₂ in the flue gas reacts with CaO to form solid calcium carbonate (CaCO₃),
10 heating CaCO₃ formed in the carbonation reactor in a calcination reactor (130) operating at a temperature at which CaCO₃ is converted to CaO and CO₂, whereby said heating is at least partially effected by indirect heat exchange with the hot flue gas stream from the combustion, and
 recirculating CaO formed in the calcination reactor back to the
15 carbonation reactor,
characterized in that
 the flue gas used for indirect heat exchange in the calcination reactor is subsequently subjected to dry desulfurization before it is brought into contact with CaO in the carbonation reactor.

20

2. The method according to claim 1, wherein the desulfurization is performed at a temperature in the range of 200 °C to 700 °C.

25 3. The method according to claim 2, wherein the desulfurization is performed at a temperature in the range of 200 °C to 400 °C, preferably in the range of 250 °C to 350 °C.

30 4. The method according to claim 2, wherein the desulfurization is performed at a temperature in the range of 500 °C to 700 °C, preferably in the range of 550 °C to 650 °C.

5. The method according to any one of the preceding claims, wherein the desulfurization comprises bringing the flue gas into contact with solid calcium oxide (CaO) at a temperature whereby SO₂ in the flue gas reacts with CaO to form solid calcium sulfate (CaSO₄).
- 5
6. The method according to any one of the preceding claims, further comprising the step of removing dust from the desulfurized flue gas before it is brought into contact with CaO in the carbonation reactor.
- 10
7. The method according to any one of claims 5-6, wherein the CaO used for desulfurization of the flue gas at least partially comprises CaO recovered from the CO₂ rich flue gas formed in the calcination reactor, from the flue gas stream downstream of the carbonation reactor and/or from CaO formed in the calcination reactor.
- 15
8. The method according to any one of the preceding claims, wherein the temperature in the carbonation reactor is in the range of 550 to 750 °C, preferably about 650 °C.
- 20
9. The method according to any one of the preceding claims, wherein the temperature in the calcination reactor is in the range of 800 to 1100 °C, preferably about 900 °C.
- 25
10. A system (100) for combustion of a fuel and treatment of the resulting flue gas, said system comprising:
- a furnace (101)
 - a carbonation reactor (120)
 - a calcination reactor (130)
 - 30 a dry desulfurizer (110)

wherein the furnace (101) is operative for combusting a fuel with air or oxygen to produce a hot flue gas stream containing at least carbon dioxide (CO₂) and sulfur dioxide (SO₂),

the carbonation reactor (120) is operative for bringing the flue gas
5 stream into contact with solid calcium oxide (CaO) at a temperature at which CO₂ in the flue gas reacts with CaO to form solid calcium carbonate (CaCO₃),

the calcination reactor (130) is operative for heating CaCO₃ formed in the carbonation reactor at a temperature at which CaCO₃ is converted to CaO and CO₂,

10 the calcination reactor (130) comprises means for indirect heating (104) whereby said heating of CaCO₃ is at least partially effected by indirect heat exchange with the hot flue gas stream from the combustion, and

wherein

the dry desulfurizer (110) is operative for subjecting the flue gas stream
15 to dry desulfurization before it is brought into contact with CaO in the carbonation reactor (120).

11. The system according to claim 10, wherein the dry desulfurizer is configured to operate at a temperature in the range of 200 °C to 700 °C.

20

12. The system according to any one of claims 10-11, wherein the dry desulfurizer is operative for bringing the flue gas into contact with solid calcium oxide (CaO) at a temperature whereby SO₂ in the flue gas reacts with CaO to form solid calcium sulfate (CaSO₄).

25

13. The system according to any one of claims 10-12, wherein the dry desulfurizer is in fluid connection with and configured to receive CaO recovered from a dust removal unit (132) operative for removing CaO from the CO₂ rich flue gas formed in the calcination reactor.

30

14. The system according to any one of claims 10-13, wherein the dry desulfurizer is in fluid connection with and configured to receive CaO

recovered from a dust removal unit (124) operative for removing CaO from the flue gas stream downstream of the carbonation reactor.

15. The system according to any one of claims 10-14, wherein the dry
5 desulfurizer is in fluid connection with and configured to receive CaO formed in the calcination reactor.

16. The system according to any one of claims 10-15, further
10 comprising a dust removal unit (115) operative for removal of dust from the desulfurized flue gas before it is brought into contact with CaO in the carbonation reactor (120).

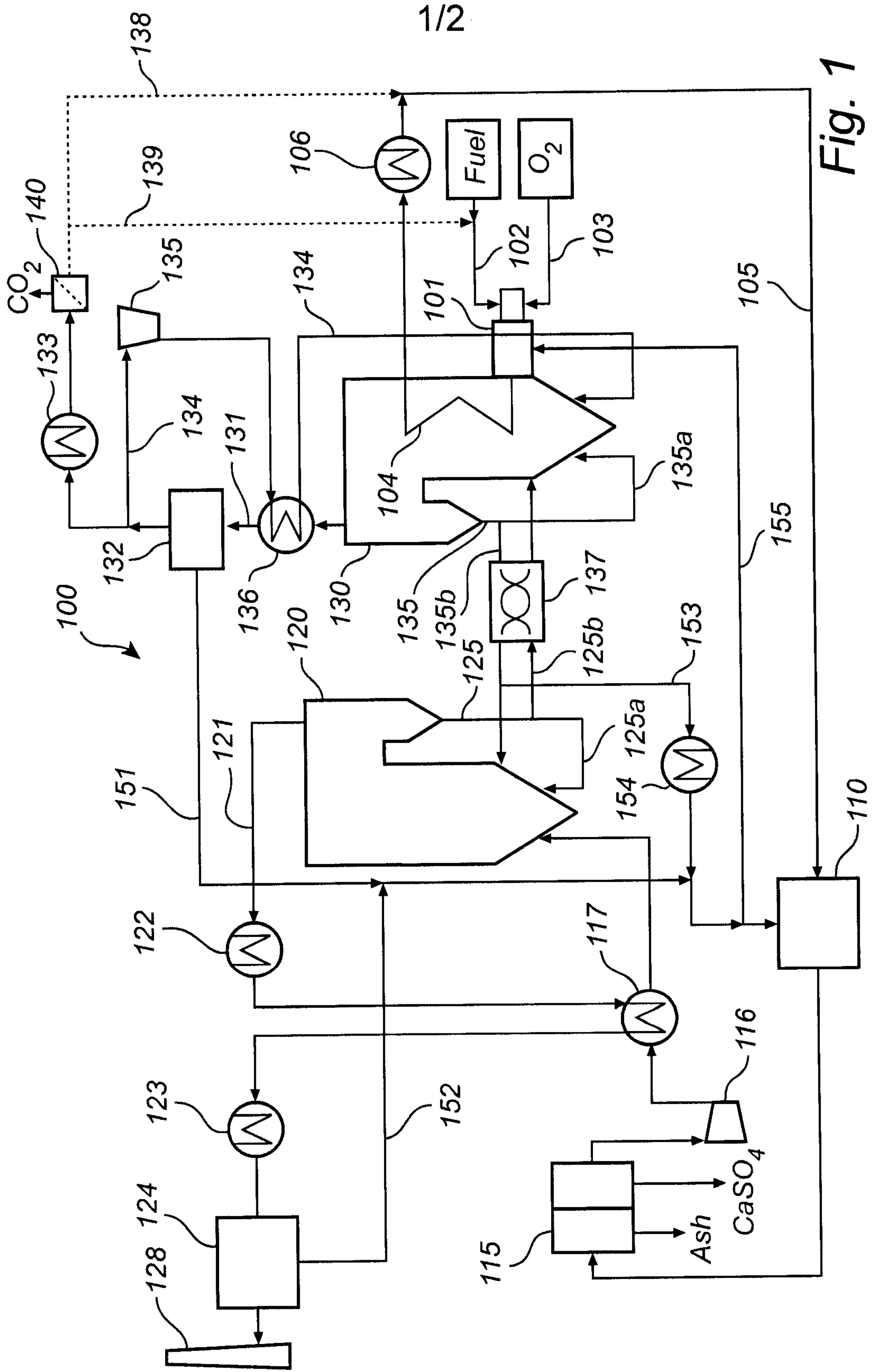

Fig. 1

