

[54] DRIVE MECHANISM EMPLOYING SUCTION CUP COUPLING

[76] Inventor: Edwin E. Messmer, 203 Leonard Young Street, Oradell, N.J. 07649

[22] Filed: Aug. 6, 1971

[21] Appl. No.: 169,666

[52] U.S. Cl. .... 214/1 BT, 192/130, 287/85 R, 287/130

[51] Int. Cl. .... B66c 1/02

[58] Field of Search.....100/53; 192/130; 287/85 R, 287/86, 130; 214/1 B, 1 BB, 1 BT

[56] References Cited

UNITED STATES PATENTS

3,087,722	4/1963	Neuberger .....	214/8.5 D X
3,655,070	4/1972	Haydu .....	214/1 BB
2,856,999	10/1958	Wilhelm .....	100/53

Primary Examiner—Robert G. Sheridan  
Assistant Examiner—George F. Abraham  
Attorney—Breitenfeld & Levine

[57] ABSTRACT

A drive mechanism including a drive member, such as a piston movable within a pneumatic cylinder, a working member, such as a label applicator for transferring labels from a supply strip to merchandise packages, and a coupling for transmitting motion from the drive member to the working member. The coupling includes at least one, and preferably a pair of opposed suction cups which adhere to each other, but which separate to break the driving connection when the working member meets more than a predetermined resistance. When one suction cup is employed, it cooperates with a member having a flat surface.

11 Claims, 5 Drawing Figures

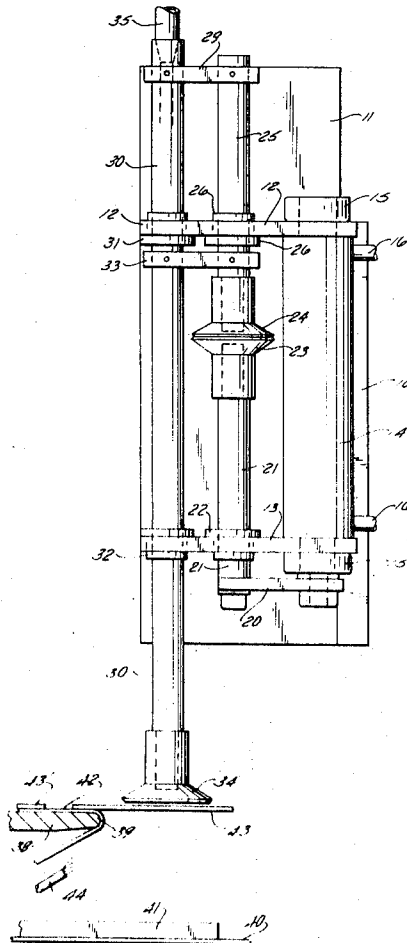

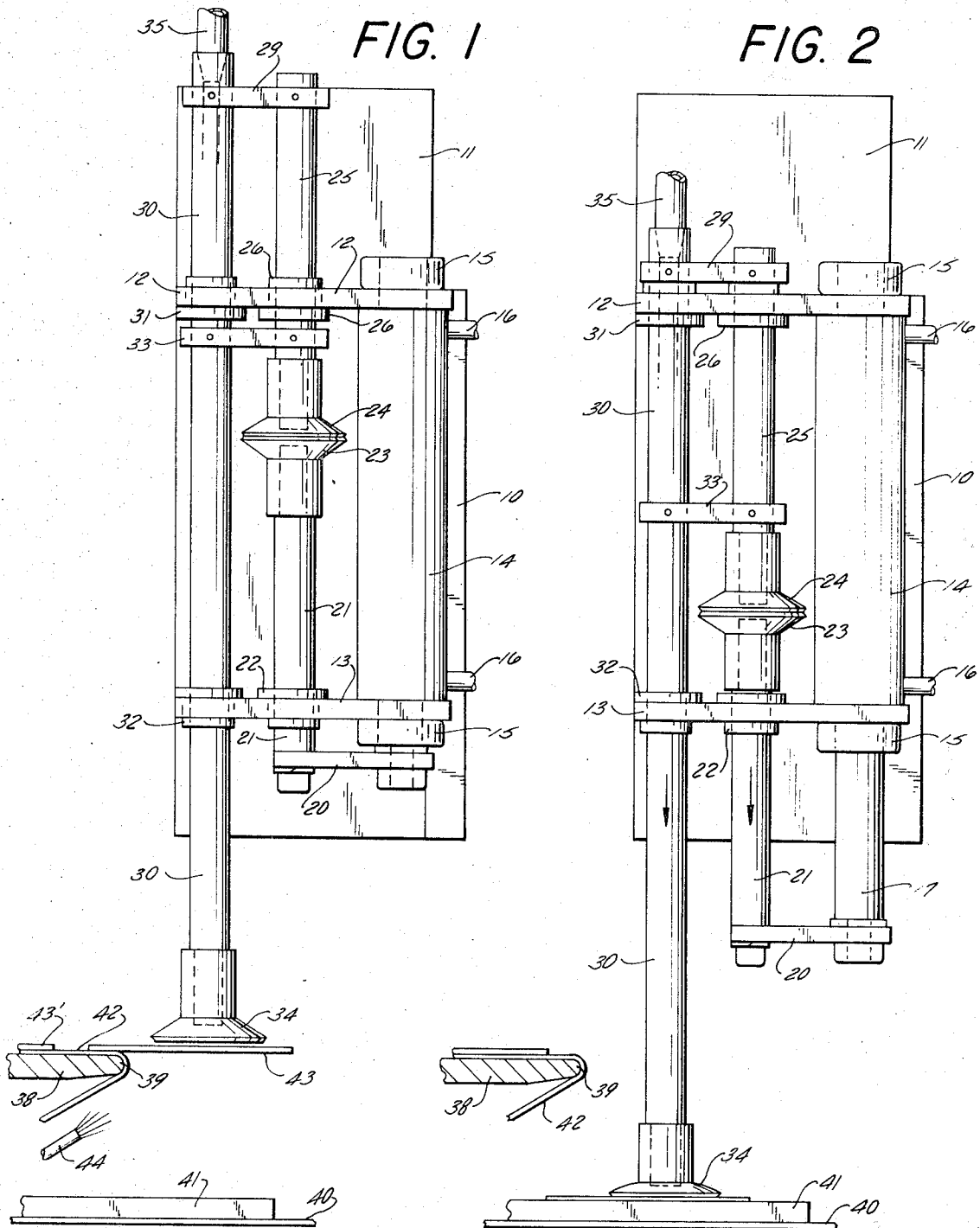

INVENTOR:  
EDWIN E. MESSMER  
BY  
*Breitenfeld & Levine*  
ATTORNEYS

FIG. 3

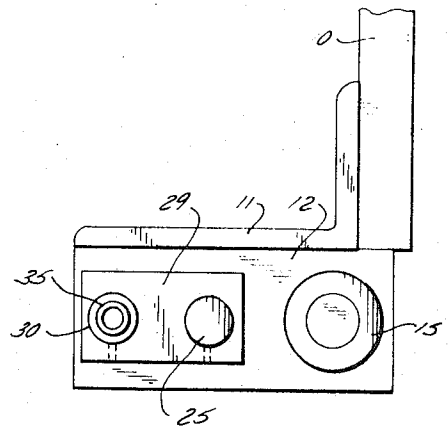
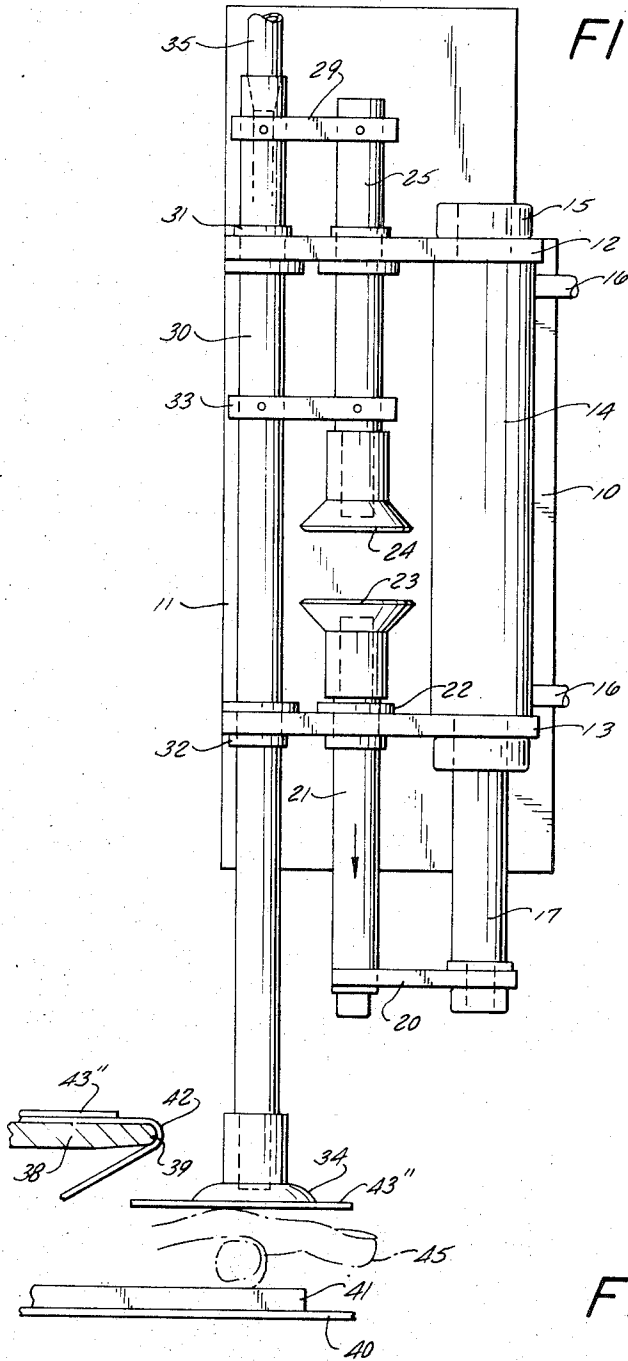

FIG. 4

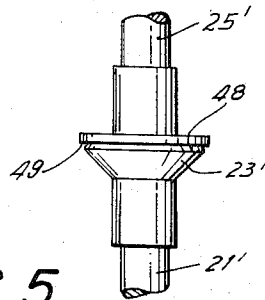

FIG. 5

INVENTOR:  
 EDWIN E. MESSMER  
 BY  
*Breitenfeld & Levine*  
 ATTORNEYS

## DRIVE MECHANISM EMPLOYING SUCTION CUP COUPLING

This invention relates to a drive mechanism in which the motion of a drive member is transmitted to a working member and more particularly to such mechanisms including as a safety precaution means for discontinuing transmission of motion to the working member when the latter meets a higher than predetermined resistance.

Drive mechanisms of this type find utility in a great variety of apparatus, an example of which is a label applicator. In one type of applicator, labels are fed one at a time to an applicator head which is reciprocated toward and away from a support surface upon which packages to be labeled are placed. It is important, to prevent possible injury to personnel working with the apparatus, and damage to the apparatus and packages, that the driving connection between the drive member and the applicator head be temporarily broken should the applicator head meet an unusual resistance, such as would happen if the machine operator accidentally left his hand beneath the applicator head. Devices offering this type of operation are available, and include slip clutches and spring biased detent arrangements.

It is a general object of the present invention to provide a transmission arrangement which automatically discontinues transmitting motion from a drive member to a working member when the latter meets more than a predetermined resistance, which is simpler and less expensive to make and service than conventional arrangements for accomplishing the same result.

It is a more specific object of the invention to provide a separable coupling, comprising at least one but preferably two opposed suction cups, for transmitting motion from a drive member to a working member.

A feature of the invention is its simplicity of operation. Motion is transmitted through the two adhered suction cups. Hence, any time the force required to move the working member exceeds the force required to pull the suction cups apart, the suction cups separate and movement of the working member is discontinued. The transmission is reestablished simply by pushing the suction cups together again so that they adhere to each other.

It is another object of the invention to mount the suction cups on elements movable in fixed bearings so that the suction cups always remain accurately aligned.

Additional objects and features of the invention will be apparent from the following description, in which reference is made to the accompanying drawings.

In the drawings:

FIG. 1 is an elevational view of part of a label applicator incorporating the present invention;

FIG. 2 is a view similar to FIG. 1, showing a label being applied to a package;

FIG. 3 is a view similar to FIG. 1 showing the coupling separated as a result of the applicator head meeting an abnormal resistance;

FIG. 4 is a top view of FIG. 1; and

FIG. 5 is a fragmentary elevational view of an alternative coupling according to the invention.

The drive mechanism chosen to illustrate the present invention is shown forming part of a label applicator apparatus. A portion of the frame 10 of this apparatus is shown, and fixed to the frame is one arm of a rigid angle member 11. Secured to the other arm of angle 11

are two vertically spaced-apart horizontal plates 12 and 13.

Mounted between plates 12 and 13 is a vertical pneumatic cylinder 14 within which a piston (not shown) is slidable axially. A threaded member projects from each end of cylinder 14 through a hole in its respective plate 12 or 13, and a nut 15 threaded on to each member holds cylinder 14 rigidly in place. Cylinder 14 is provided with a port near each end, a conduit 16 being connected to each port. Conduits 16 are connected to suitable air pressure apparatus (not shown) so that either side of the piston within the cylinder may be subjected to air pressure, or exhausted, as a result of which the piston is moved up and down within cylinder 14. Connected to the piston is a piston rod 17 which projects through the lower end of cylinder 14. Thus, by the pneumatic arrangement just described, piston rod 17 is reciprocated between a retracted position shown in FIG. 1 and an extended position shown in FIG. 2.

Fixed to the lower end of piston rod 17 is one end of a link 20, the other end of which is fixed to the lower end of a rod 21. Rod 21 slides vertically within a bearing 22 fixed within an opening in plate 13. At its upper end, rod 21 carries a suction cup 23, the concave surface of which faces upwardly.

A second suction cup 24, the concave surface of which faces downwardly, is carried at the lower end of a rod 25 slidable vertically within a bearing 26 carried by plate 12. The axes of rods 21 and 25 are colinear, and they are maintained in vertical alignment by being retained within their fixed bearings 22 and 26, respectively. As a result, suction cups 23 and 24 always meet precisely head-on for maximum adherence between them. Furthermore, since rods 21 and 25 do not tilt with respect to each other, suction cups 23 and 24 are never even partially pried apart. As a result, the only way in which suction cups 23 and 24 are separated is by being pulled apart in a vertical direction.

A link 29 rigidly connects the upper end of rod 25 to the upper end of a hollow tube 30. Tube 30 is arranged to slide vertically within bearings 31 and 32 fixed within openings in plates 12 and 13, respectively. Another link 33 extends between tube 30 and rod 25 to help rigidify the assembly. At its lower end, tube 30 carries a label applicator head in the form of a suction cup 34. A flexible conduit 35 is connected to the upper end of tube 30 and to a source of suction (not shown), the suction being transmitted through the interior of tube 30 to an opening at the center of suction cup 34.

The label applicator apparatus includes a stationary horizontal plate 38 having an edge 39. Beneath plate 38 and applicator head 34 is a support surface 40 upon which a package 41 to be labeled is placed. A backing strip 42 carrying a series of labels 43, 43', etc. is intermittently advanced along the upper surface of plate 38, and its direction of movement is sharply reversed around edge 39. As a result of this sharp reversal of movement, label 43 is stripped from the backing, and the label is temporarily supported by a stream of air issuing from a tube 44. Labels 43 carry a pressure-sensitive adhesive coating on their lower faces, by means of which they are removably secured to backing strip 42 and will ultimately be secured to package 41.

With the parts in the position shown in FIG. 1, label 43 is attracted to applicator head 34 by virtue of the

suction present at the head. To perform the labeling operation, pneumatic cylinder 14 is operated to move piston rod 17 downwardly. This movement is transmitted through link 20, rod 21, interconnected suction cups 23 and 24, rod 25, and link 29 to tube 30. As tube 30 and head 34 move downwardly, label 43 is carried with the head and applied to package 41 below, as shown in FIG. 2. Cylinder 14 is then operated to lift the parts to the position shown in FIG. 1 preparatory to the next cycle of operation.

It may happen that an operator will inadvertently leave his hand 45 beneath applicator head 34. Consequently, when head 34 strikes the hand 45, there will be an abnormal resistance to further downward movement of head 34. This resistance is transmitted through tube 30, link 29 and rod 25 to suction cup 24. On the other hand, suction cup 23 continues its downward movement. As a result, suction cups 23 and 24 are pulled apart, as shown in FIG. 3, so that no further downward motion is transmitted to applicator head 34. In this way, injury to the hand 45 is avoided, and abnormal stress and possible damage to the machine parts is also avoided. Upon the next upward stroke of piston rod 17, suction cup 23 is pushed against suction cup 24 to reestablish the separable connection between the two suction cups.

The present invention is also advantageous when labelling packages of varying heights, since no adjustment for different height packages is necessary. Should a high package be placed beneath applicator head 34, the applicator head will move downwardly until it strikes the package, and upon further downward movement of piston rod 17, suction cups 23 and 24 will separate. The label, however, will have been applied to the package. Upon each upward return stroke of piston rod 17 and rod 21, suction cups 23 and 24 are reengaged. Should a low package be placed beneath applicator head 34, the parts will operate as shown in FIGS. 1 and 2.

Suction cups 23 and 24 are preferably removable from their respective rods 21 and 25, and replaceable with suction cups of smaller or larger diameter. In this way, the predetermined force required to separate the suction cups may be varied.

The coupling described above employs two suction cups. However, the invention also contemplates a coupling utilizing only one suction cup 23', as shown in FIG. 5. Parts in FIG. 5 which correspond to parts in FIGS. 1-4 bear the same reference numerals as their corresponding parts followed by a prime. In the arrangement of FIG. 5, one of the suction cups is replaced by a rigid plate 48 having a flat surface 49 facing suction cup 23'. This coupling operates in the same way as the coupling described above, since when suction cup 23' is pressed against surface 49 it adheres to the surface. Upon the application of a sufficient force to rods 21' and 25' tending to pull suction cup 23' and plate 48 apart, the suction cup and plate separate.

The invention has been shown and described in preferred form only, and by way of example, and many variations may be made in the invention which will still be comprised within its spirit. It is understood, therefore, that the invention is not limited to any specific form or embodiment except insofar as such limitations are included in the appended claims.

What is claimed is:

1. A drive mechanism comprising:
  - a. a drive member serving as a source of motion;
  - b. a movable working member;
  - c. bearing means supporting said working member and guiding its movement, and
  - d. a coupling for transmitting motion from said drive member to said working member, said coupling including two parts which separably adhere to each other when engaged with sufficient force, at least one of said parts being a suction cup, said parts being operatively connected to said drive member and said working member, respectively, and said parts being separable by a separating force higher than some predetermined value, whereby when said working member meets more than a predetermined resistance during its movement said parts separate so that movement of said working member stops while said drive member continues its operation.
2. A drive mechanism as defined in claim 1 wherein each of said parts is a suction cup.
3. A drive mechanism as defined in claim 1 wherein the other of said parts is a member having a flat surface facing the concave surface of said suction cup.
4. A drive mechanism as defined in claim 1 wherein said working member has a working stroke during which it moves in one direction and a return stroke during which it moves in another direction, the force applied to said coupling during said working stroke being one which tends to separate said parts.
5. A drive mechanism as defined in claim 4 wherein each of said parts is a suction cup having a concave surface which engages the other suction cup, the concave surface of said suction cup operatively connected to said drive member facing in a direction opposite to the direction in which said working member moves during its working stroke.
6. A drive mechanism as defined in claim 1 wherein said drive and working members move along parallel paths, and the axis of said suction cup is parallel to said paths.
7. A drive mechanism as defined in claim 1 including an element rigidly connected to each of said drive and working members, one of said parts being secured to each of said elements.
8. A drive mechanism as defined in claim 1 including two stationary spaced apart bearing means, a rod fixed to and movable with each of said drive and working members, each of said rods being slidable in one of said bearings, the axes of said rods being colinear and parallel to the direction of movement of said drive and working members, and each of said rods carrying one of said parts.
9. A drive mechanism as defined in claim 1 wherein said working member is a label applicator for transferring a label from a supply source to a delivery position.
10. A drive mechanism as defined in claim 9 wherein said label applicator includes a working head having an opening facing each label which it transfers, and means for applying suction to said opening to cause the label to adhere to said working head.
11. A drive mechanism as defined in claim 9 wherein said label applicator reciprocates through opposite working and return strokes, a label being transferred during each working stroke, said parts tending to separate during each working stroke and being pressed together during each return stroke.