

March 3, 1964

I. BRONSON

3,123,218

SELF-LEVELING DEVICE

Filed Aug. 16, 1960

FIG. 1

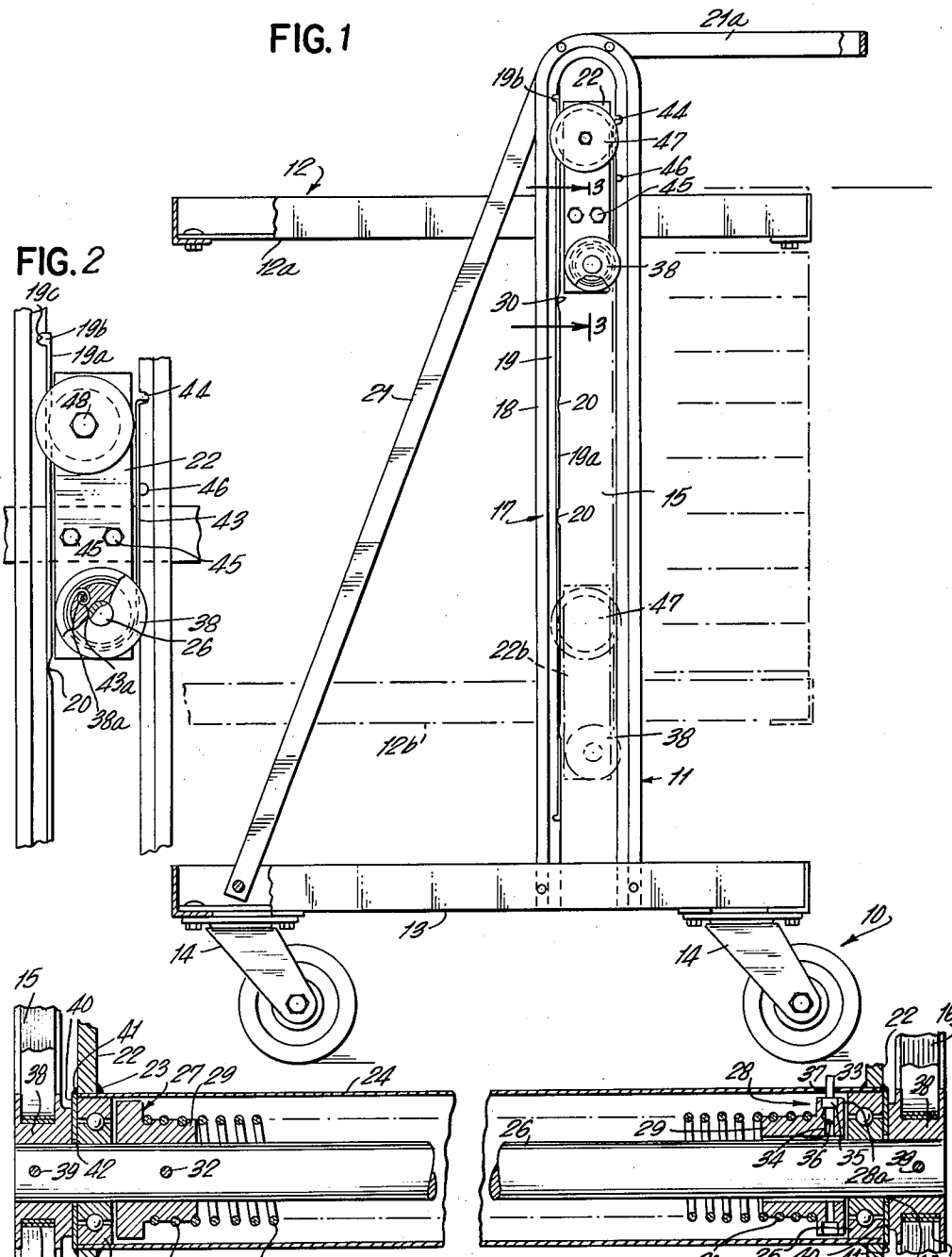

FIG. 2

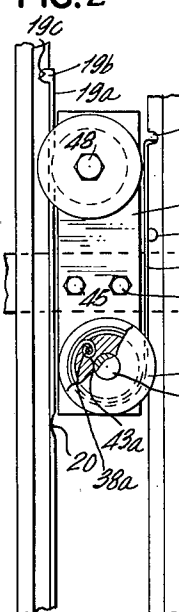
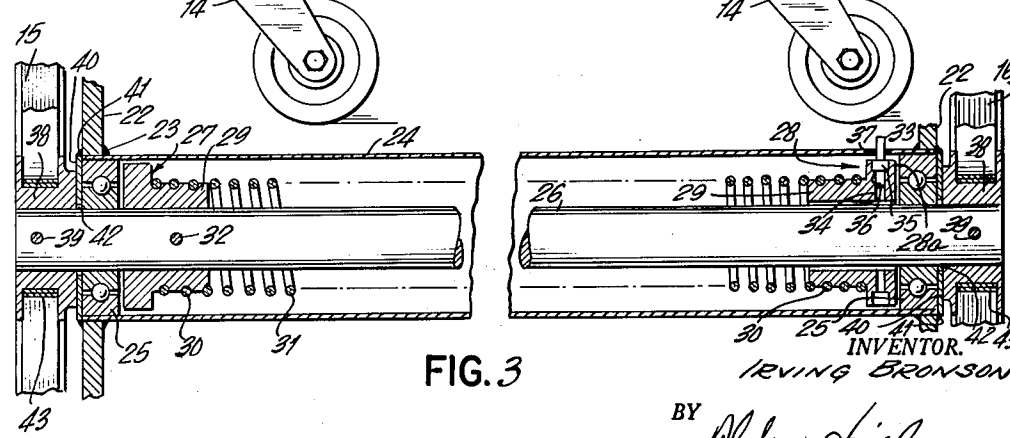

FIG. 3



INVENTOR.  
IRVING BRONSON

BY *Arthur J. Fisher*  
ATTORNEY

1

3,123,218

**SELF-LEVELING DEVICE**

Irving Bronson, Brooklyn, N.Y., assignor, by mesne assignments, to American Machine & Foundry Company, New York, N.Y., a corporation of New Jersey  
 Filed Aug. 16, 1960, Ser. No. 49,856  
 9 Claims. (Cl. 211-49)

This invention relates to a self-leveling device for receiving, storing and dispensing articles.

The subject matter of this application is related to my copending applications Serial No. 49,857 and Serial No. 49,912, both filed simultaneously herewith.

Under many circumstances, it is desirable to dispose a series of articles in stacked relation upon a wheel-mounted carrier and to remove said articles therefrom as desired. Thus, for example, restaurants or similar food service institutions may require that a series of dish racks be stacked as they are removed from a dishwashing machine and thereafter transported to another location at which the racks are unloaded as required. In this, as well as in many other applications, it is quite important that the loading and unloading points be maintained at a constant level regardless of the number of stacked articles disposed upon the carrier in order to minimize the amount of effort required and to maintain the uppermost rack or article at the most desirable level. Although self-leveling devices of this character have been suggested, they have been characterized by shortcomings which are overcome by the instant invention.

It is therefore an object of this invention to provide a self-leveling device for receiving, storing and dispensing articles which is simple in arrangement and construction and which effectively maintains a plurality of articles in stacked relation, with the uppermost article being maintained at a predetermined level regardless of the number of articles comprising the stack.

Another object of this invention is to provide a self-leveling device of the character indicated which may be readily adjusted to accommodate various stacks of articles as when it is desired to change over from a stack comprised of articles of a certain weight and vertical dimension to a stack comprised of articles of a different unit weight and vertical dimension.

It is also an object of this invention to provide a device of the character indicated wherein it is not necessary to employ special types of spring elements in order to provide for the maintenance of a stack of articles at a predetermined constant level regardless of the number of articles comprising the stack and variations in the characteristics of the group.

An additional object of this invention is to provide an arrangement wherein a stack elevating spring arrangement is employed which provides for varying the leverage exerted upon the spring means to accord with the degree of winding or unwinding thereof. It is a further object to provide means for adjusting the initial spring tension and degree of leverage exerted thereon.

This invention also has for its object the provision of a device of the character indicated wherein positioning means are provided for accurately locating the uppermost article of the stack at a predetermined elevation.

Other and further object of this invention will become apparent from the description thereof contained in the annexed specification, or will otherwise become obvious. It will be understood that the invention here disclosed

2

may be employed for other purposes to which the structure and arrangement are adapted.

In the accompanying drawings:

FIGURE 1 is a side elevational view of a self-leveling device embodying the features of the instant invention, partly in section and also showing the carrier platform under load in broken lines;

FIGURE 2 is a fragmentary side elevational view of one of the carriage assemblies employed in the self-leveling device depicted in FIGURE 1, said carriage assembly being in operative association with one of the upright frame assemblies provided in said device; and

FIGURE 3 is a cross-sectional view taken about the line 3—3 of FIGURE 1.

A self-leveling, receiving, storing and dispensing device embodying the features of the instant invention is illustrated in FIGURE 1 of the accompanying drawing. As may be seen from said figure, the device comprises a wheel-mounted base assembly, designated generally by the numeral 10, which supports an upright frame assembly, designated generally by the numeral 11. A carrier assembly, designated generally by the numeral 12, receives, stores and dispenses the desired articles and is mounted for vertical movement on the upright frame assembly 11. Articles, such as dish racks for example, are stacked upon the carrier platform 12a of the carrier assembly and with the placement of each successive rack thereon, the stack is depressed or lowered so that the uppermost article in the stack is always at the same working level. Conversely, as each article is successively removed from the stack, the entire remaining stack is elevated so that the next succeeding article is brought up to the desired working level.

The base assembly 10 in the form of the invention illustrated comprises a generally rectangular frame 13 which is advantageously formed of angle members of steel, aluminum or other suitable material. The frame is further provided with casters 14, which are mounted adjacent the corners of the base. By forming the base in the manner indicated, it is possible to make use of this portion of the device for further storage of used racks for example. Thus, as a new rack is removed from the stack upon the carrier platform which is elevated as a consequence of such removal, a used rack may be disposed upon the frame assembly in the space thus formed.

The upright frame assembly 11 is mounted upon the wheeled base 10 and comprises a pair of vertical trackways 15 and 16, disposed on the opposing sides of the base frame 13. Each of trackways 15 and 16 comprises a guide rail 17 having a flange portion 18 and a head portion 19. As will be more particularly seen from FIGURES 1 and 2, the rail head 19 is advantageously provided with an insert 19a having a plurality of vertically spaced arcuate indentations 20 which serve as positioning detents for the carriage rollers, as will be more particularly apparent hereafter.

Furthermore, it should be noted that the insert 19a is removably secured to the rail head as by flanges 19b formed on the ends of said insert and received within suitable slots 19c provided in the rail head 19, thereby enabling the insert to be removed and replaced as required due to wear, or for the purpose of substituting an insert having differently spaced indentations. On each side of the base assembly an inclined brace member 21 extends from the base to the upper portion of the guide rails. The guide rail itself, including the rail head and flange

portion is formed in the shape of an inverted U, as may be seen in FIGURE 1, and a suitable horizontal handle 21a of U-shaped conformation is rigidly secured to the upper extremity of each of the guide rails.

Each of the guide rails receives a vertically movable carriage assembly which supports an important feature of this invention residing in the means for presetting a spring drum so as to provide a predetermined resistance to variation in the level of the carrier platform 12a.

Thus, as may be seen by reference to FIGURES 1 to 3, the upright frame assembly houses a pair of rectangular carriage plates 22 which are rigidly secured, as by welding 23, to a transverse hollow drum 24. At each end of this drum, there is housed a ball bearing 25 which rotatably secures a shaft 26. Intermediate of said bearings 25 are provided a pair of flanged collars, generally designated by the numerals 27, 28, the bodies 29 of said collars 27, 28 being formed with grooves 30 to receive a coiled torsion spring 31. One of the collars 27 is secured to the shaft 26 by a radially disposed pin 32 and the other of said collars 28 is rotatable with respect to the shaft 26. The ends of the aforesaid coiled torsion spring 31 are also affixed to the collars so that any rotation of the collar 28 with respect to the shaft 26 imparts a set or corresponding resistance to any opposing rotation which may be exerted upon the shaft 26.

The rotation of the collar 28 with respect to the shaft 26 may be accomplished by means of a detent or pin 33 which is removably receivable within a plurality of equally spaced-apart radial apertures 34 formed in the flanged portions 28a of said collar 28, the said detent or pin 33 being provided with an expanded annular portion 35 which is seatable upon annular shoulders 36 formed in each of said radial apertures 34. The said pin 33 is also slidably received in a slot 37 formed in the hollow drum 24.

It will be noted from the foregoing arrangement that the coiled torsion spring 31 may be rotated with respect to the shaft 26 by simply rotating the detent or pin 33 so that it will be displaced from an initial position at one end of the slot 37 to the other end thereof. Upon such rotation, another of the said radial apertures 34 is aligned with that end of the slot which was occupied by the detent or pin 33 prior to its aforesaid rotation. To maintain this position, another of said pins 33 may be inserted in said last-mentioned aperture so as to be biased against the edge of the slot by the force of the torsion spring. Further rotation of the collar 28 with respect to the shaft 26 may also be accomplished in a similar manner so as to align successively any of the apertures 34 with the ends of the slot 37 and produce any desired amount of torsion in the spring 31.

The shaft is maintained within the drum 24 by a pair of opposing flanged pulleys 38 secured to the shaft by suitable fastening elements such as transverse pins 39. The pulleys 38 are rotatably contactable with a pair of washers 40 affixed to the carriage plates 22 as by welding 41, the ends of the shaft projecting through apertures 42 in said washers. The aforesaid ball bearings are abutable against said washers without however, experiencing interference with their rotatability. Pulleys 38 bear on the right trackway 17, viewing FIGURE 1, due to the counterclockwise moment of the carriage.

The external periphery of each of the pulleys 38 receives a flexible member, such as a flexible band 43, which is secured to pulley, as by a suitable pin 38a disposed within a loop 43a formed at one end of the band, said band also being supported by the rail heads 19, the other end of said band being secured within an aperture 44 formed at the upper portion of the rail heads. In this manner, the carriage plates are supported within the vertical trackways 15, 16 and since said plates are affixed to the carrier assembly, as by bolts 45, the said carrier assembly is also supported between said trackways.

It will be seen from this arrangement that the coiled spring 31 may be initially deflected to any desired extent by rotation of the detent or pin 33. Such deflection of the torsion spring 31 together with the corresponding counter-pull of the band 43 will vary the lifting force applied to the carrier platform to accommodate items of different weights.

To extend the range of operation of the bands, additional apertures may be provided in the rail heads, as at 46.

With this arrangement, any given weight placed upon the platform of the carrier assembly will accomplish a corresponding deflection of the band and of the carriage plate and carrier assembly, as, for example, to the position depicted in broken lines in FIGURE 1 and designated by the numerals 12b and 22b, the amount of such deflection being determined by the moment arm of said band with respect to the axis of the shaft 26 and the present torsion of the coiled spring 31. In this connection, it will be particularly noted that the moment arm of the band will shorten as the carrier platform descends and the counter-pull of the spring increases and the said moment arm will lengthen as the carrier platform rises and the counter-pull of the spring decreases.

It will also be noted that the axis of each of the pulleys is in an offset position with respect to the vertical axis of the carriage plate 22. In the upper portion of the carriage plate 22 in each trackway, a carriage roller 47 is mounted, each of said rollers being provided with suitable flanged portions for engagement with the trackways. As may be seen in FIGURES 1 and 2, the band contacts the periphery of the pulley at a point which is offset with respect to the vertical axis of the carriage plate, thereby canting the carriage roller into contact with the insert disposed upon the forward portion of the guide rail, the cylindrical body portion of said carriage roller being receivable within the vertically spaced arcuate indentations 20.

The carriage roller may be suitably mounted upon the carriage plate by a conventional shaft and nut assembly 48, said mounting permitting rotational movement of the carriage roller.

As previously noted, the arcuate indentations 20 serve as positioning detents for carriage rollers. Thus, when the carriage assembly has been lowered by a weight imposed upon the carriage platform to a position wherein said rollers are in the approximate vicinity of the centers of said arcuate indentations, i.e., where the rollers make contact with any portion of said indentations, the rollers tend to be forced to the center of said indentations by the canting action of the band, as aforesaid. In this way, the level of the carriage assembly, and hence of the carrier platform, will tend to be definitely determined at positions corresponding with the arcuate indentations.

With this arrangement, the carrier platform may receive a plurality of articles of equal weights, such as dish racks, the uppermost of said racks being maintained at a predetermined level. When the stacks are composed of a different weight, the level thereof may be adjusted by approximate setting of the spring drum. It will be seen that such adjustment is easily, quickly and conveniently accomplished, and does not require the employment of specialized spring elements, the coiled torsion spring within the spring drum being of conventional design. Moreover, a definite positioning of the carrier platform is accomplished without the necessity of using a delicate or unduly complex mechanism.

The embodiment of the invention illustrated and described hereinabove has been selected for the purpose of clearly setting forth the principles involved. It will be apparent, however, that the present invention is susceptible to being modified in respect to details of construction, combination and arrangement of parts which may be resorted to without departure from the spirit and scope of the invention as claimed.

I claim:

1. An improved self-leveling device comprising in combination a base member supporting an upright frame, a vertically movable carriage associated with said frame, said carriage supporting carrier means, torsion spring means, said carriage being supported by a flexible member communicating between said upright frame and said torsion spring means, and means for imparting an initial set to said spring means, whereby the topmost portions of articles provided on said carrier means are maintained at a constant level independently of the number of such articles, said torsion spring means being non-linear, and non-resilient means operable in response to carriage movement to compensate for said non-linearity.

2. An improved self-leveling device comprising in combination a base member supporting an upright frame, a vertically movable carriage retained within said frame, said carriage supporting a platform adapted for receipt of a plurality of articles, said carriage being supported by at least one flexible band communicating between said upright frame and a pulley affixed to a rotatable shaft, said shaft being biased by a non-linear coiled torsion spring disposed thereon, said shaft being provided with means for imparting an initial deflection to said coiled torsion spring, whereby the topmost portions of said articles are maintained at a constant level independently of the number of such articles, said band being wound on said pulley in a winding the diameter of which varies in response to carriage movement to provide a variable moment arm relative to the axis of said shaft so as to compensate for the non-linearity of said spring.

3. An improved self-leveling device comprising in combination a base member supporting an upright frame, a vertically movable carriage retained within said frame, said carriage supporting a platform for receipt of a plurality of articles, said carriage including an elongated plate secured within said frame and provided with a roller, the said roller being in rollable contact with a plurality of arcuate indentations provided upon said frame, said elongated plate being supported by a flexible band and, canting said roller into contact with the portion of said frame whereon said arcuate indentations are provided, the said arcuate indentations being disposed at a predetermined spaced relation with respect to the platform, said flexible band communicating with pulley means affixed to a rotatable shaft, said shaft being biased by a coiled torsion spring disposed thereon, said shaft being provided with means for imparting an initial deflection to said coiled torsion spring, whereby the topmost portions of said articles are maintained at a constant level independently of the number of such articles.

4. An improved self-leveling device comprising in combination a base member including a generally rectangular frame provided with a plurality of casters, said base member supporting a pair of upright trackways disposed upon opposing sides of said base member, each of said trackways being formed in an inverted U-shaped conformation and being provided with a guide rail having a flange portion and a head portion, the said head portion being provided with a removable insert having a plurality of equally spaced-apart arcuate indentations, the said inserts being provided with flanged portions received within slotted portions of the said guide rail, a pair of vertically movable rectangular plates disposed within said trackways and supporting a generally rectangular platform adapted for receipt of a plurality of racks of equal weights, the said rectangular plates being provided with a pair of pulleys mounted upon a shaft extending through said rectangular plates and a pair of ball bearings supporting a rotatable tubular drum, said shaft also being provided with a pair of flanged collars upon which is seated a coiled torsion spring, one of said collars being affixed by pin means to said shaft, the other of said collars being rotatably secured to said shaft and provided

with a plurality of radial apertures, the said apertures being engageable with a removable radial pin abutable against the ends of a slot formed in the tubular drum, said last-mentioned collar being rotatable by said pin to impart a predetermined deflection to said torsion spring, said spring being securable in the position of such deflection by the abutment against one end of said slot of another radial pin received within another of said apertures; each end of said shaft being provided with a rotatable pulley upon which is wound and secured a flexible band, the said band also being supportably secured within at least one slot provided in the head portion of the guide rail, each of the said pulleys being rotatable upon vertical movement of said rectangular plates to vary the moment arm of said bands with respect to the axis of said torsion spring, each of the said rectangular plates being provided with a flanged roller contactable with the said insert, the said band and said platform cooperating to urge said roller into contact with said insert and said arcuate indentations therein.

5. In an improved self-leveling device having a base member, a pair of upright trackways and a platform supported by a vertically movable carriage housed within each of said trackways, the combination comprising a flexible band affixed to each of said upright trackways and windably received upon the periphery of a rotatable pulley affixed to said carriage, said carriage being provided with rollable positioning means abutable against each of said trackways, the said flexible band and the center of gravity of said platform being offset with respect to the axis of said pulley to bias said positioning means against one side of each of said trackways and against arcuate indentations provided thereon, the said arcuate indentations determining preselected positions of said platform.

6. A self-leveling device comprising a platform, means mounting said platform for vertical movement, non-linear torsion spring means mounted for movement with said platform, pulley means operatively secured to said spring means and rotatably biased thereby, a flexible member having one end secured against movement relative to said mounting means and the other end engaged with said pulley means so that said flexible member is windable on said pulley means for raising and lowering said platform in response to the weight of a load disposed thereon, the diameter of said winding being variable in response to movement of said platform for providing a variable moment arm to compensate for said non-linearity.

7. A self-leveling device comprising a platform, means mounting said platform for vertical movement, non-linear torsion spring means, pulley means operatively secured to said spring means and rotatably biased thereby and a flexible member supporting said carriage and windable on said pulley means to raise and lower said platform in response to the weight of a load disposed thereon, the diameter of said winding being variable in response to movement of said platform for providing a variable moment arm to compensate for said non-linearity.

8. A self-leveling device as in claim 7, said pulley means being operatively secured to said platform, one end of said flexible member being engaged on said pulley means and the other end thereof being secured to said mounting means.

9. An improved self-leveling device comprising in combination a base member supporting an upright frame, a vertically movable carriage retained within said frame, said carriage supporting a platform adapted for receipt of a plurality of articles, said carriage being supported by at least one flexible cable communicating with reel means affixed to a rotatable shaft, said shaft being biased by a coiled torsion spring disposed thereon, said shaft being provided with means for imparting an initial deflection to said coiled torsion spring, whereby the top-

most portions of said articles are maintained at a constant level independently of the number of such articles, said reel means having means to vary the leverage exerted upon said spring, said torsion spring being secured upon a collar rotatably disposed upon said shaft and provided with a plurality of equally spaced-apart radial apertures, a removable pin received within said apertures and abutable against the ends of a slotted portion of a drum surrounding said torsion spring, said collar being rotatable to align successively said radial apertures with the ends of said slot, said collar being securable in said aligned

positions by the abutment of said removable pin against one end of the slot.

References Cited in the file of this patent

UNITED STATES PATENTS

2,318,567	Duerig -----	May 4, 1943
2,444,776	Kalning et al. -----	July 6, 1948
2,690,948	Seyter -----	Oct. 5, 1954
2,932,057	Pemberton -----	Apr. 12, 1960
2,944,672	Simpson -----	July 12, 1960