

(19)



Europäisches Patentamt

European Patent Office

Office européen des brevets



(11)

EP 0 664 366 B1

(12)

EUROPEAN PATENT SPECIFICATION

(45) Date of publication and mention
of the grant of the patent:

27.01.1999 Bulletin 1999/04

(51) Int Cl.⁶: **E04D 1/04**

(21) Application number: **94203570.0**

(22) Date of filing: **07.12.1994**

(54) **Roofing tile**

Dachziegel

Tuile pour toitures

(84) Designated Contracting States:

ES FR GR IT PT

Designated Extension States:

SI

(30) Priority: **21.01.1994 IT PD940005 U**

30.09.1994 IT PD940103 U

(43) Date of publication of application:

26.07.1995 Bulletin 1995/30

(73) Proprietor: **FORNACE LATERIZI VARDANEGA
ISIDORO S.r.l.**

31054 Possagno (TV) (IT)

(72) Inventors:

- **Vardanega, Giuseppe**
I-31054 Possagno (TV) (IT)
- **Vardanega, Tarcisio**
I-31054 Possagno (TV) (IT)

(74) Representative: **Cantaluppi, Stefano et al**
c/o JACOBACCI & PERANI S.p.A.

Via Berchet, 9
35131 Padova (IT)

(56) References cited:

DE-C- 840 591

FR-A- 989 570

FR-A- 1 084 080

FR-A- 2 223 529

FR-A- 2 457 354

EP 0 664 366 B1

Note: Within nine months from the publication of the mention of the grant of the European patent, any person may give notice to the European Patent Office of opposition to the European patent granted. Notice of opposition shall be filed in a written reasoned statement. It shall not be deemed to have been filed until the opposition fee has been paid. (Art. 99(1) European Patent Convention).

Description

This invention relates to an improved roofing tile having an intrados surface and an extrados surface with a major longitudinal dimension. A roofing tile of this kind is identified, according to its specific shape, as a bent tile when rounded in the form of a frusto-conical segment, imbrex when tapered but almost flat in shape, and plain tile when rectangular in plan view with corrugations and rib formations. The invention applies to all these types of roofing tiles, although it is primarily and preferably directed to bent tiles.

These roofing tiles, referred to as tiles hereinafter for brevity, are laid into alternating courses wherein one tile has its extrados facing up and is flanked by another tile with its extrados down and partly overlapped by it. In their current form, tiles have two major drawbacks. A first drawback is that the tiles with their extrados down, through being arranged to rest directly on the beam and rafter framework of a roof to be covered, introduce a restriction to the free circulation of air between the roof framework and the tile covering, resulting in moisture becoming trapped and encouraging the onset of rot in the roof framework. Another drawback is that the tiles are held in their working positions almost exclusively by friction opposing their tendency to slide down. The holding action is, therefore modest, and the tiles can easily become dislodged over time and cause the roof to leak.

DE-C-840.591 and FR-A-989.570 disclose bent tiles having two parallel ridges of even thickness extending longitudinally on the extrados surface thereof. These ridges may interfere with the ventilation of the roof, especially in a direction transverse to the tiles.

FR-A-2.223.529 discloses a flat tile having two pairs of continuous ridges on both sides, each ridge having an intermediate, relatively thin section and two relatively thicker and sections. The end sections are both spaced apart from the corresponding longitudinal tile edge. The tile may therefore be tilted if a concentrated load is applied at the tile edge.

A further tile according to the prior art is known from FR-A-2.457.354.

The problem at the basis of this invention is that of providing improved tiles structurally and functionally designed to overcome the inconvenience considered in connection to the cited prior art.

This problem is solved by the invention, with a tile as claimed in the appended claims 1 and 2.

The features and advantages of the invention will be more clearly apparent from the following detailed description of some preferred embodiments thereof, shown, by way of example and not of limitation, in the accompanying drawings, in which:

Figure 1 is a perspective view of a first embodiment of a bent tile according to the present invention; Figures 2 and 3 are side elevation views, taken from either sides of the tile in Figure 1;

Figures 4 and 5 are top and bottom plan views, respectively, of the tile in Figure 1;

Figures 6 and 7 are elevation views from the two longitudinal ends of the tile in Figure 1;

Figure 8 is a partial perspective view from above of a roof assembled with the tiles of the preceding Figures;

Figure 9 is a side elevation view of the roof in Figure 8;

Figures 10 to 16, 17 to 23, 24 to 30, 31 to 37, 38 to 44, 45 to 51, 52 to 58 are similar views to Figures 1 to 7, showing further embodiments of the tile according to this invention;

Figures 59 and 60 are elevation views, taken from a longitudinal end, showing respectively two further embodiments of the tile according to this invention.

With reference to Figures 1 to 9, generally indicated at 1 is a tile according to a first embodiment of this invention. The tile 1 is a bent tile with opposed intrados 2 and extrados 3 surfaces, and has a major longitudinal dimension with longitudinally opposed ends respectively indicated at 4 and 5. In view of the typical frusto-conically bent shape of the tile, the surfaces 2 and 3 are tapered from the end 4 to the opposite end 5, and said ends will also be referred to herein as the large end and small end.

Formed on the extrados surface 2, integrally with the tile 1 during the tile molding or extrusion process, are symmetrically arranged two ridges, being mirror-images of each other and both indicated at 6, which ridges are radially oriented, i.e. perpendicularly to the surface 3 and run lengthwise of the tile 1. Such ridges 6 extend in parallel at a spacing from each other, are symmetrical about a longitudinal mid-plane of the tile 1, and extend from the large end 4 to a location at a predetermined distance from the small end 5, in a region 7 which is also referred to as the covering region, i.e. the area where a tile is, within the layout of a roof generally denoted by T, in a relationship of partial overlap with a longitudinally adjacent tile 1.

The ridges 6 have first and second contiguous sections 6a, 6b, the first section having a smaller longitudinal dimension and a taller ridge on the extrados surface than the second section. The section 6a has opposed end bevels, both indicated at 8. During the installation of the roof T, the section 6a of the ridges 6 provides support for the corresponding tile end raised over the roof framework 10, while the free end of the section 6b, by abutting against the large end of the longitudinally adjacent tile, forms a stop for the latter, thereby preventing it from sliding relatively. Notice that, in assembling the roof T (or the like covering), functional advantages can be secured by using tiles configured according to the invention at least for those tiles whose extrados surface is to be laid facing the roof framework 10. While it is preferred that the whole covering be formed of tiles 1 according to this invention, it is also contemplated that the

other tiles having their extrados facing up may have a traditional bent tile shape.

The other embodiments of this invention will now be described limited to those features which they differ from the tile 1, it being understood that similar parts to those of the previous embodiment will be denoted by the same reference numerals.

Figures 10 to 16 show a tile 40, in which the ridges 6 are tapered from the small end 5 toward the large end 4.

A tile 50 is shown in Figures 17 to 23 which is similar to the tile 40, except that the ridges 6, instead of having a radial orientation, lie parallel to each other, that is perpendicular to the plane of the roof T.

In Figures 24 to 30, a tile 60 is shown which is similar to the tile 1, except that the ridges 6 include each a taller section 6a on the surface 3, a lower section 6c of shorter longitudinal dimension, and an intermediate section 6b of still lower height interconnecting the two sections 6a and 6c.

A tile 70 is shown in Figures 31 to 37 which is similar to the tile 1, except that the ridges 6 are not provided with bevel 8 at the large end 4.

Figures 38 to 44 show a tile 80 which is similar to the tile 70, except that its ridges 6, instead of being radially oriented, extend parallel to each other, that is perpendicular to the plane of the roof T.

Figures 45 to 51 and Figures 52 to 58 respectively show tiles 110, 120 in which the sections 6d of the ridges 6 do not have a constant height on the extrados surface 3, but follow a tapering pattern consistent with that of the respective tiles 50 and 40 previously described.

Finally, with reference to Figures 59 and 60, two further embodiments of the invention, respectively indicated at 150 and 160, have the intrados surface provided with rest surfaces, respectively a raised one 151 and a recessed one 161, effective to engage in bearing relationship the back side 9 of the corresponding ridges 6 of an overlying tile to facilitate stacking of the aforesaid tiles.

Among the major advantages afforded by the invention, is the improved ventilation of the roof, an optimal retention of one tile by another, and an easier and more efficient stacking of the tile for shipping.

Claims

1. An improved roofing tile having an intrados surface (2) and an extrados surface (3) with a major longitudinal dimension, at least one ridge (6) running lengthwise along said extrados surface (3) and being raised on said surface, said at least one ridge (6) extending over a shorter length than the longitudinal dimension of the tile (1), said at least one ridge (6) including first and second contiguous sections (6a, 6b), the first section (6a) having a shorter longitudinal dimension and greater height on the

extrados surface (3) than the second section (6b), said at least one ridge (6) having only one of said first section (6a) and said first section being located at one longitudinal end (4) of the tile, characterized in said at least one ridge (6) extending continuously from one longitudinal end (4) of said tile (1) to a location at a predetermined distance from the other tile end (5) where said tile (1) has a covering region (7), said ridge (6) having a free end at said covering region forming an abutment surface for a longitudinally adjacent tile.

2. An improved roofing tile having an intrados surface (2) and an extrados surface (3) with a major longitudinal dimension, at least one ridge (6) running lengthwise along said extrados surface (3) and being raised on said surface, said surfaces (2, 3) having a near-conical pattern, characterized in the height of said ridge over the extrados surfaces continuously increasing with said surface taper.
3. A tile according to claim 1 or 2, having a bent tile structure.
4. A tile according to any of the preceding claims, wherein at least two spaced apart ridges (6) extend along substantially parallel directions.
5. A tile according to claim 2, wherein said at least one ridge (6) extends from one longitudinal end (4) of said tile to a location at a predetermined distance from the other tile end (5) where said tile has a covering region (7).
6. A tile according to one or more of the preceding claims, having a frusto-conically bent shape defining longitudinally opposite large end small ends (4, 5) of said tile, said first section (6a) of the at least one ridge (6) being located at said large end (4) of the tile.
7. A tile according to one or more of the preceding claims, wherein said ridges (6) form ribs of said tile.
8. A tile according to claim 2, wherein said at least one ridge (6) includes first and second contiguous sections (6a, 6b), the first section (6a) having a shorter longitudinal dimension and greater height on the extrados surface than the second section (6b).
9. A tile according to one or more of the preceding claims, wherein the ridges (6) have an approximately radial orientation relative to the extrados surface (3).
10. A tile according to one or more of the preceding claims, wherein the ridges (6) are parallel to each other.

11. A tile according to one or more of the preceding claims, wherein, formed on said intrados surface (2), are rest surfaces (151, 161) for the back side (9) of the corresponding ridges (6) of an overlying tile to facilitate the stacking of said tiles.
12. A covering (T) including a framework (10) and a plurality of tiles laid in side-by-side rows and alternately with the extrados (3), or respectively the intrados (2), surface facing toward said framework (10), wherein at least the tiles with the extrados surface (3) facing toward said framework (10) are as claimed in one or more of the preceding claims.

Patentansprüche

1. Ein verbesserter Dachziegel mit einer Innengewölbefläche (2) und einer Außengewölbefläche (3) größerer Längsabmessung und mindestens einem Steg (6), der sich in Längsrichtung entlang der Außengewölbefläche (3) erstreckt und aus dieser Fläche hervorsteht und dieser Steg (6) kürzer ausgebildet ist als die Längsabmessung des Ziegels (1), wobei der mindestens eine Steg (6) erste und zweite aneinanderstoßende Abschnitte (6a, 6b) besitzt, deren erster Abschnitt (6a) auf der Außengewölbefläche (3) kürzer und höher dimensioniert ist als der zweite Abschnitt (6b) und der mindestens eine Steg (6) nur einen der ersten Abschnitte (6a) aufweist und der erste Abschnitt (6a) sich an einem Längsende (4) des Ziegels befindet, **dadurch gekennzeichnet**, daß der mindestens eine Steg (6) sich durchgehend von einem Längsende (4) des Ziegels (1) bis zu einer Position in einer vorbestimmten Entfernung von dem anderen Ziegelende (5) erstreckt und der Ziegel (1) einen Abdeckbereich (7) besitzt, wobei die Rippe (6) ein freies Ende in dem Abdeckbereich (7) aufweist, das als Widerlagerfläche für einen in der Längsrichtung angrenzenden Ziegel dient.
2. Verbesserter Dachziegel mit einer Innengewölbefläche (2) und einer Außengewölbefläche (3) größerer Längsabmessung, mindestens einem Steg (6), der sich in Längsrichtung entlang der Außengewölbefläche (3) erstreckt und sich über diese Fläche erhebt, wobei diese Flächen (2, 3) nahezu konisch ausgebildet sind, dadurch gekennzeichnet, daß die Höhe dieses Stegs (6) entsprechend der Konizität kontinuierlich ansteigt.
3. Ziegel gemäß Ansprüchen 1 oder 2, der eine gebogene Form aufweist.
4. Ziegel gemäß irgendeinem der vorgenannten Ansprüche, in dem mindestens zwei in einem Abstand voneinander angebrachte Stege (6) sich im wesent-

lichen in Parallelrichtung erstrecken.

5. Ziegel gemäß Anspruch 2, bei dem der mindestens eine Steg (6) sich von einem Längsende (4) des Ziegels bis zu einer Position in einem vorbestimmten Abstand von dem anderen Ziegelende (5) erstreckt und der Ziegel einen Abdeckbereich (7) besitzt.
6. Ziegel gemäß irgendeinem der vorgenannten Ansprüche, der stumpfkegelig gebogen ausgebildet ist und in der Längsrichtung große und kleine Enden (4, 5) des Ziegels aufweist, wobei der erste Abschnitt (6a) des mindestens einen Stegs (6) sich an dem breiten Ende (4) des Ziegels befindet.
7. Ziegel gemäß irgendeinem der vorgenannten Ansprüche, bei dem die Stege (6) Rippen des Ziegels bilden.
8. Ziegel gemäß Anspruch 2, in dem der mindestens eine Steg (6) erste und zweite aneinanderstoßende Abschnitte (6a, 6b) besitzt und der erste Abschnitt (6a) kürzere Längsabmessungen aufweist und sich höher über die Außengewölbefläche erhebt als der zweite Abschnitt (6b).
9. Ziegel gemäß einem oder mehrerer vorgenannter Ansprüche, in dem die Stege (6) sich in etwa radial zur Außengewölbefläche erstrecken.
10. Ziegel gemäß einem oder mehrerer vorgenannter Ansprüche, in dem Stege (6) parallel zueinander verlaufen.
11. Ziegel gemäß einem oder mehrerer vorgenannter Ansprüche, in dem Auflageflächen (151, 161) auf der Innengewölbefläche (2) für die Rückseite (9) der entsprechenden Stege (6) eines darüberliegenden Ziegels angebracht sind, um das Stapeln der Ziegel zu erleichtern.
12. Ein Dachbelag (T), einschließlich eines Dachstuhls (10) und einer Vielzahl von Ziegeln, die in nebeneinanderliegenden Reihen angeordnet, abwechselnd mit der Außengewölbefläche (3) und der Innengewölbefläche (2) auf dem Dachstuhl (10) aufgelegt sind und mindestens die mit der Außengewölbefläche (3) auf den Dachstuhl ausgerichteten Ziegel wie in einem oder mehreren der vorgenannten Ansprüche beschrieben ausgebildet sind.

Revendications

1. Tuile perfectionnée de toiture ayant un intrados (2) et un extrados (3) avec une grande dimension longitudinale, une arête au moins (6) étant disposée

- longitudinalement le long de l'extrados (3) et étant en saillie sur cette surface, cette nervure au moins (6) s'étendant sur une longueur inférieure à la dimension longitudinale de la tuile (1), l'arête au moins (6) comprenant un premier et un second tronçon contigu (6a, 6b), le premier tronçon (6a) ayant une dimension longitudinale plus courte et une hauteur plus grande à l'extrados (3) que le second tronçon (6b), ladite arête au moins (6) ayant uniquement le premier tronçon (6a) et le premier tronçon étant placé à une extrémité longitudinale (4) de la tuile, caractérisée en ce que ladite arête au moins (6) s'étend de façon continue d'une extrémité longitudinale (4) de la tuile (1) à un emplacement qui est à une distance prédéterminée de l'autre extrémité (5) de la tuile lorsque la tuile (1) a une région de couverture (7), l'arête (6) ayant une extrémité libre dans la région de couverture, formant une surface de butée pour une tuile longitudinalement adjacente.
- 5
2. Tuile perfectionnée de toiture ayant un intrados (2) et un extrados (3) avec une grande dimension longitudinale, une arête au moins (6) disposée longitudinalement le long de l'extrados (3) et en saillie par rapport à l'extrados, l'intrados et l'extrados (2, 3) ayant un dessin presque conique, caractérisée en ce que la hauteur de l'arête sur l'extrados augmente de façon continue avec l'inclinaison de la surface.
- 10
- 15
- 20
- 25
- 30
3. Tuile selon la revendication 1 ou 2, ayant une structure de tuile ronde.
- 35
4. Tuile selon l'une quelconque des revendications précédentes, dans laquelle deux arêtes espacées au moins (6) s'étendent dans des directions pratiquement parallèles.
- 40
- 45
5. Tuile selon la revendication 2, dans laquelle ladite arête au moins (6) s'étend d'une première extrémité longitudinale (4) de la tuile à un emplacement qui est à une distance prédéterminée de l'autre extrémité (5) de la tuile lorsque la tuile a une région de couverture (7).
- 50
6. Tuile selon une ou plusieurs des revendications précédentes, ayant une forme ronde tronconique délimitant des extrémités large et étroite longitudinalement opposées (4, 5) de la tuile, le premier tronçon (6a) de l'arête au moins (6) se trouvant à l'extrémité large (4) de la tuile.
- 55
7. Tuile selon une ou plusieurs des revendications précédentes, dans laquelle les arêtes (6) forment les nervures de la tuile.
8. Tuile selon la revendication 2, dans laquelle la nervure au moins (6) comprend un premier et un second tronçon contigu (6a, 6b), le premier tronçon (6a) ayant une dimension longitudinale plus petite et une hauteur plus grande à l'extrados que le second tronçon (6b).
9. Tuile selon une ou plusieurs revendications précédentes, dans laquelle les arêtes (6) ont une orientation approximativement radiale par rapport à l'extrados (3).
10. Tuile selon une ou plusieurs des revendications précédentes, dans laquelle les arêtes (6) sont parallèles l'une à l'autre.
11. Tuile selon une ou plusieurs des revendications précédentes, dans laquelle les surfaces d'appui (151, 161) de la face arrière (9) des arêtes correspondantes (6) de la tuile de recouvrement sont formées sur l'intrados (2) pour faciliter l'empilement des tuiles.
12. Couverture (T) comprenant une charpente (10) et plusieurs tuiles placées en ligne côte à côte et en alternance avec l'extrados (3) ou respectivement l'intrados (2) tourné vers la charpente (10), dans laquelle les tuiles au moins qui ont l'extrados (3) tourné vers la charpente (10) sont selon une ou plusieurs des revendications précédentes.

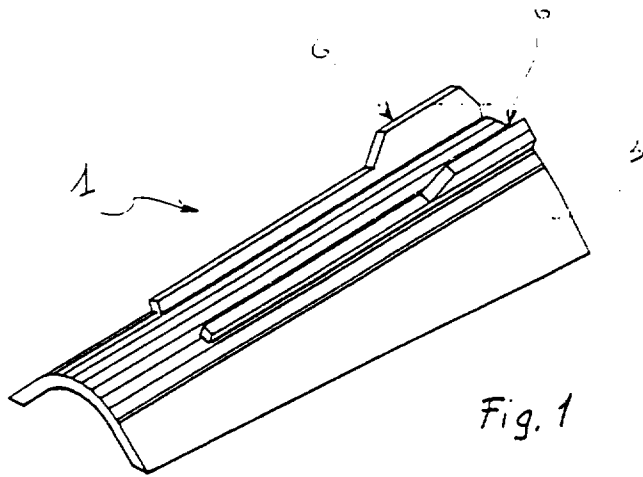

Fig. 1

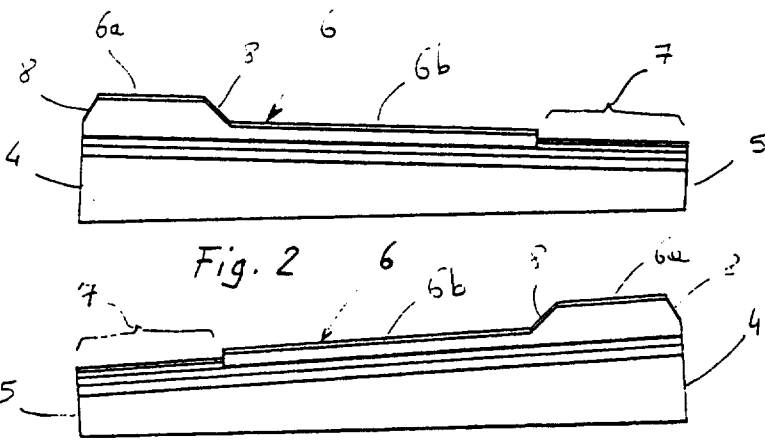

Fig. 2

Fig. 3

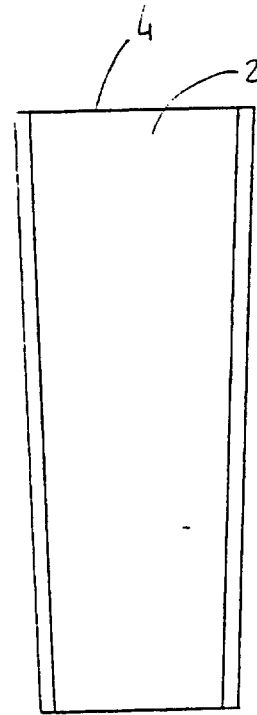

Fig. 4

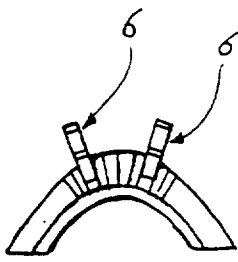

Fig. 6

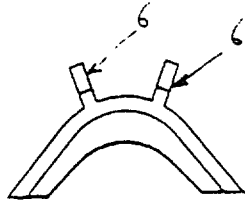

Fig. 7

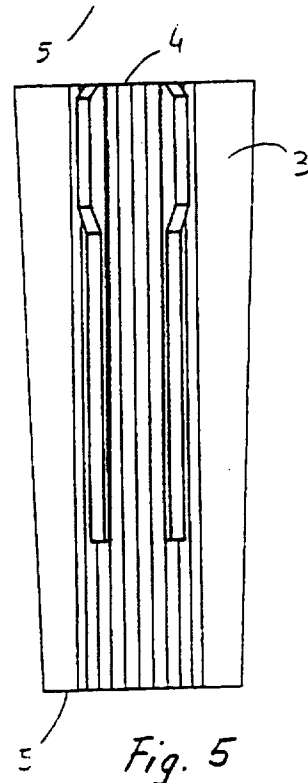

Fig. 5

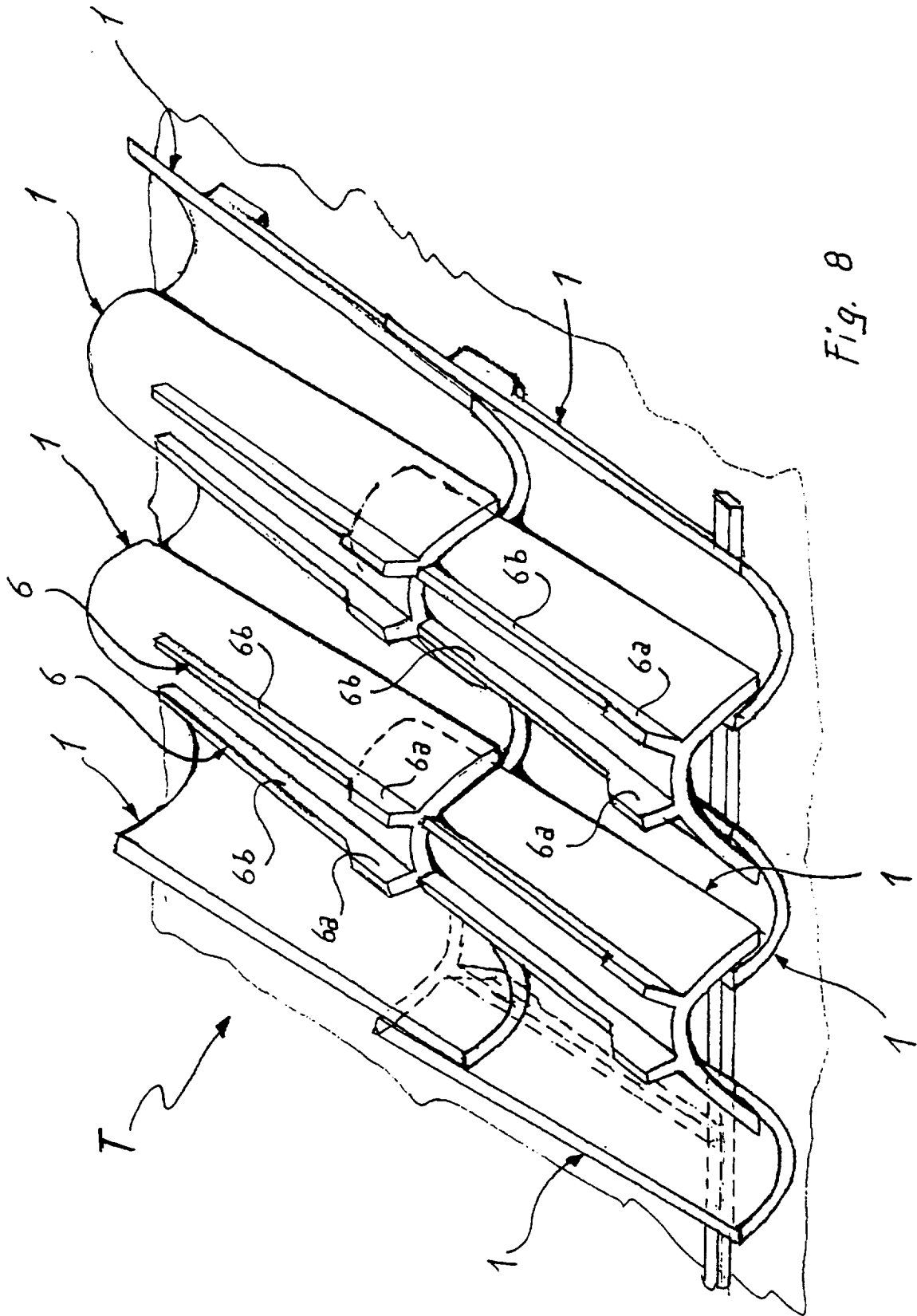

Fig. 8

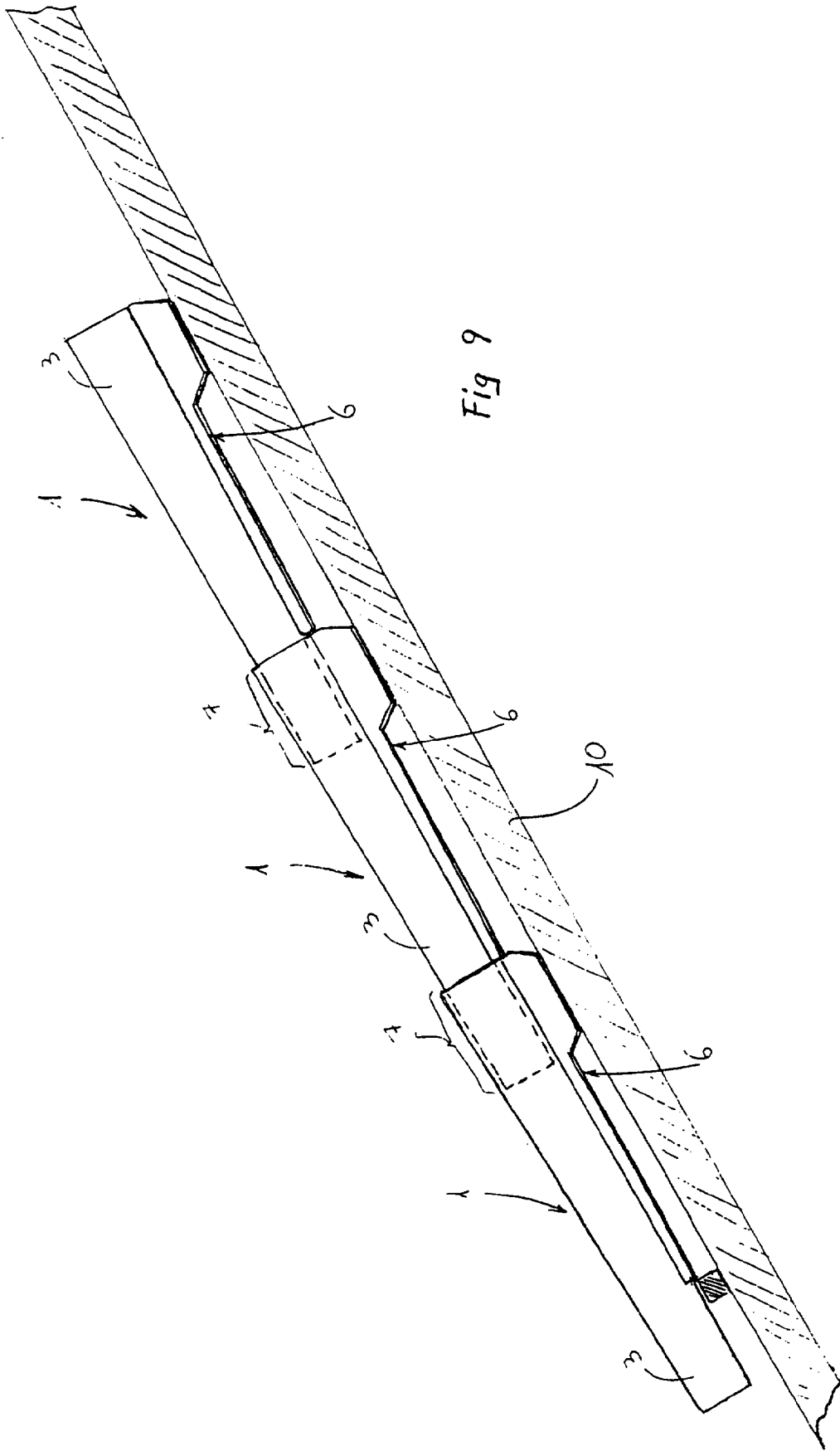
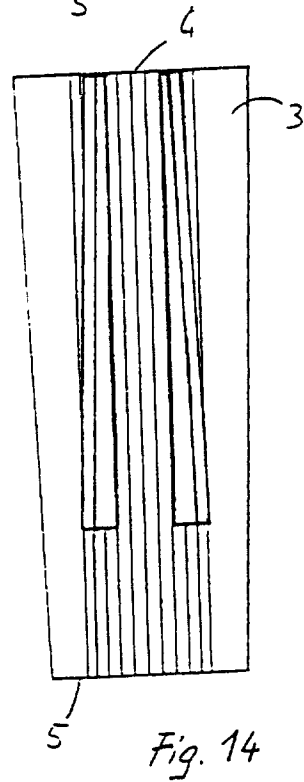
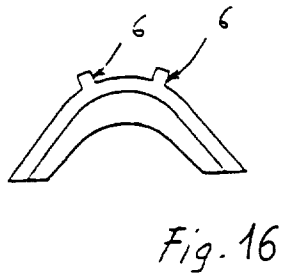
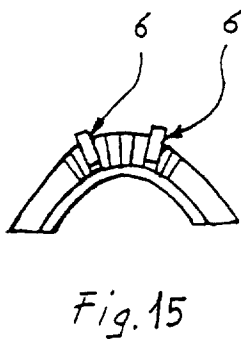
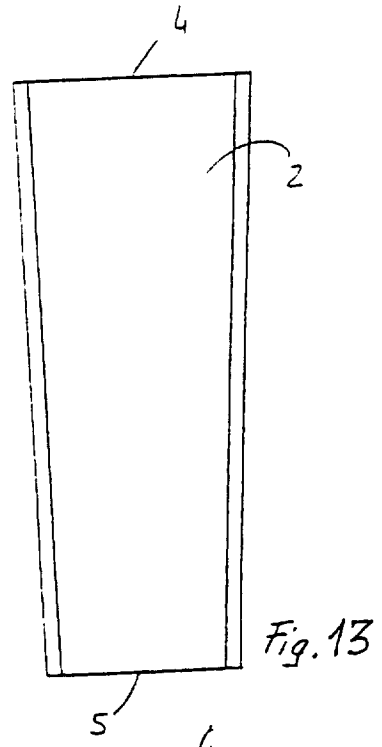
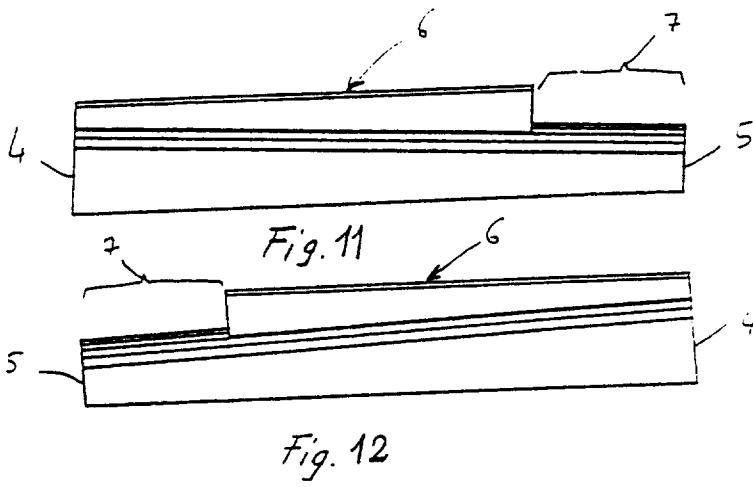
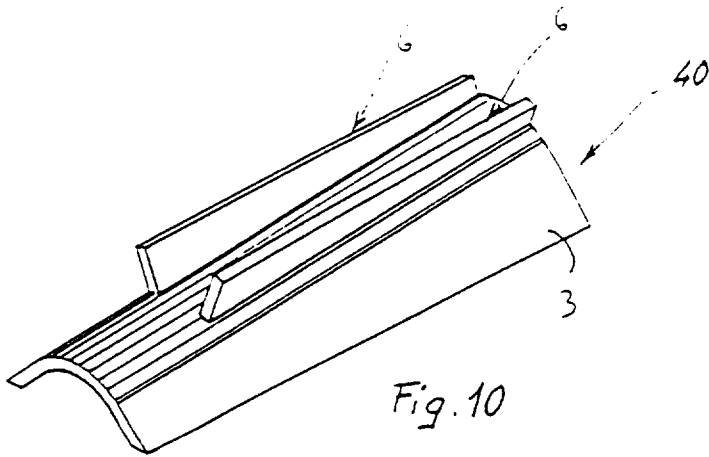
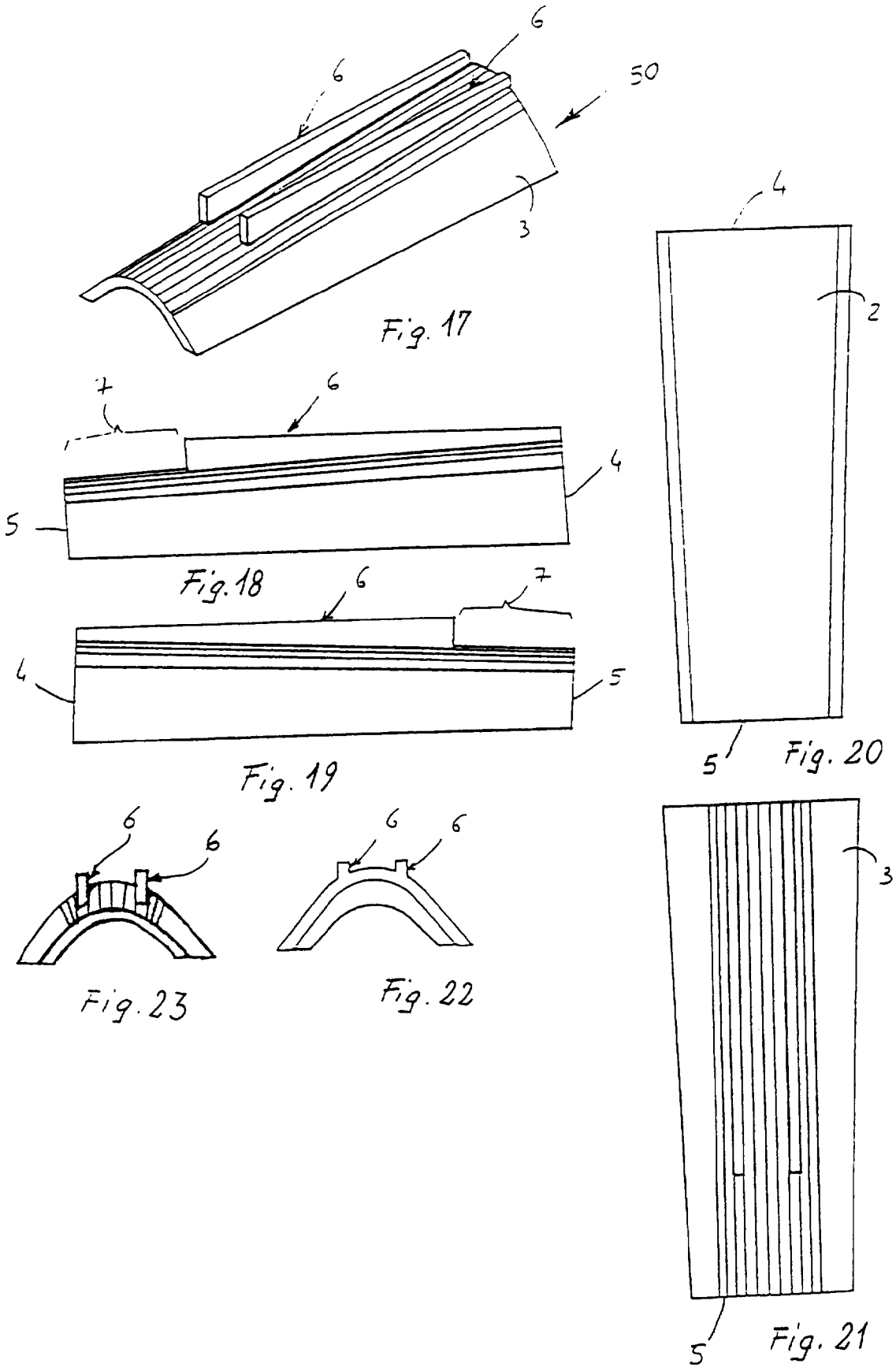

Fig 9





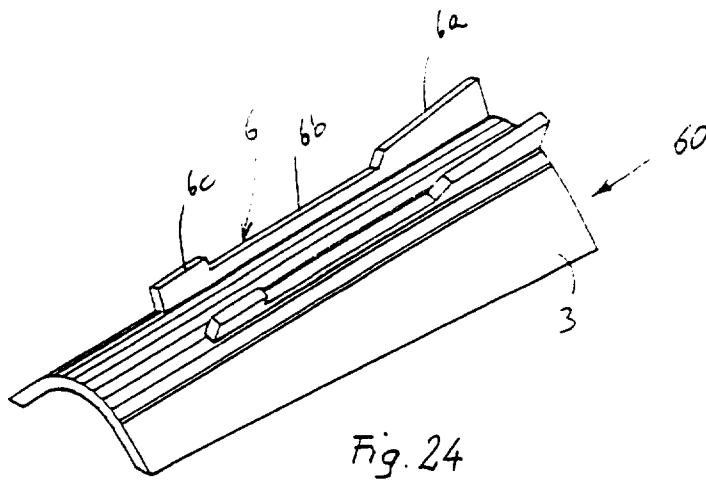

Fig. 24

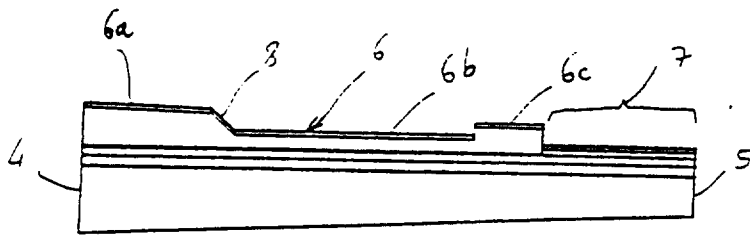

Fig. 25

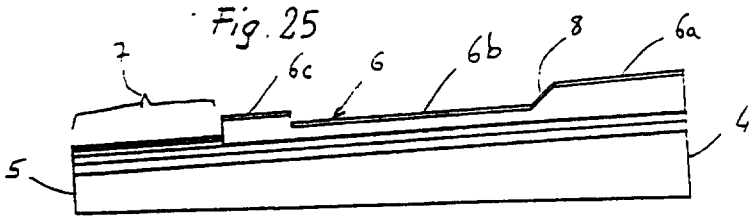

Fig. 26

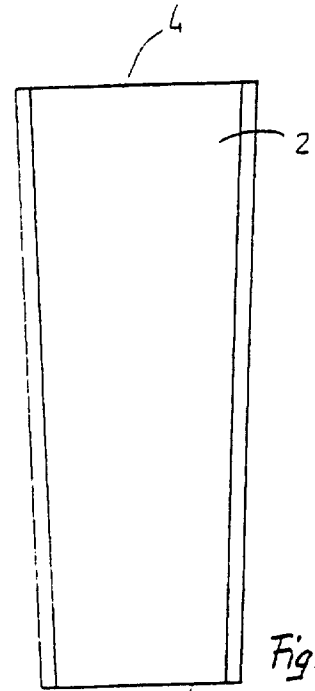

Fig. 27

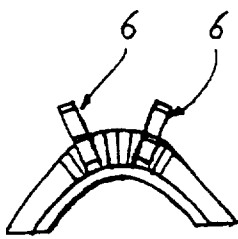

Fig. 29

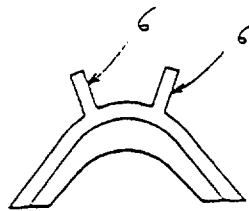

Fig. 30

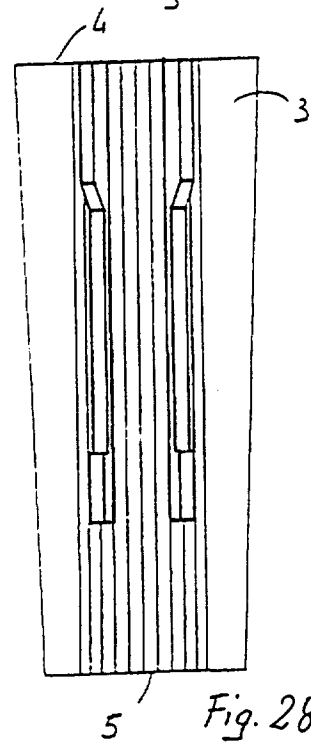

Fig. 28

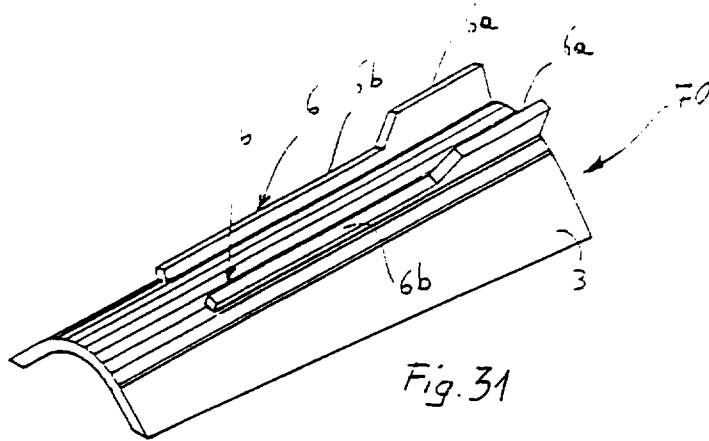

Fig. 31

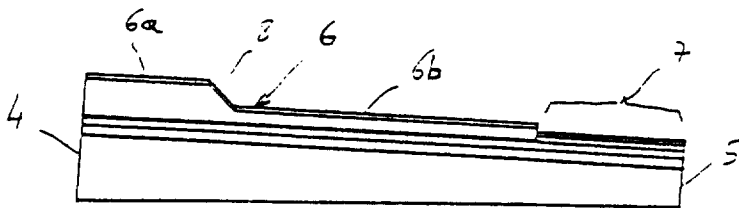

Fig. 32

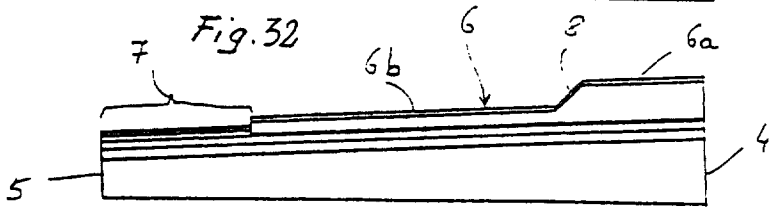

Fig. 33

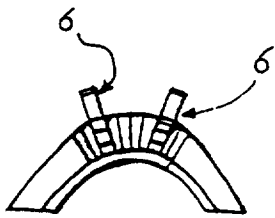

Fig. 36

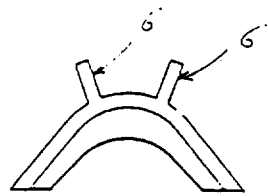

Fig. 37

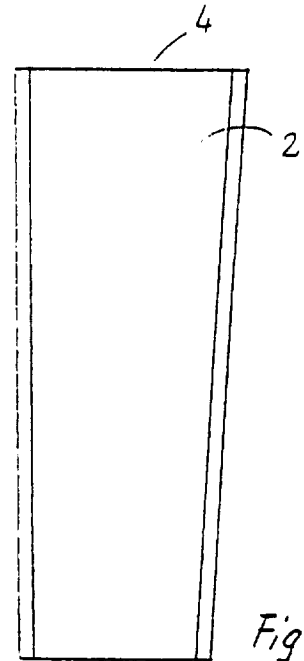

Fig. 34

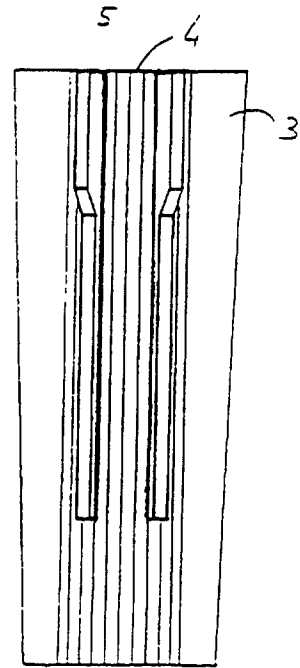
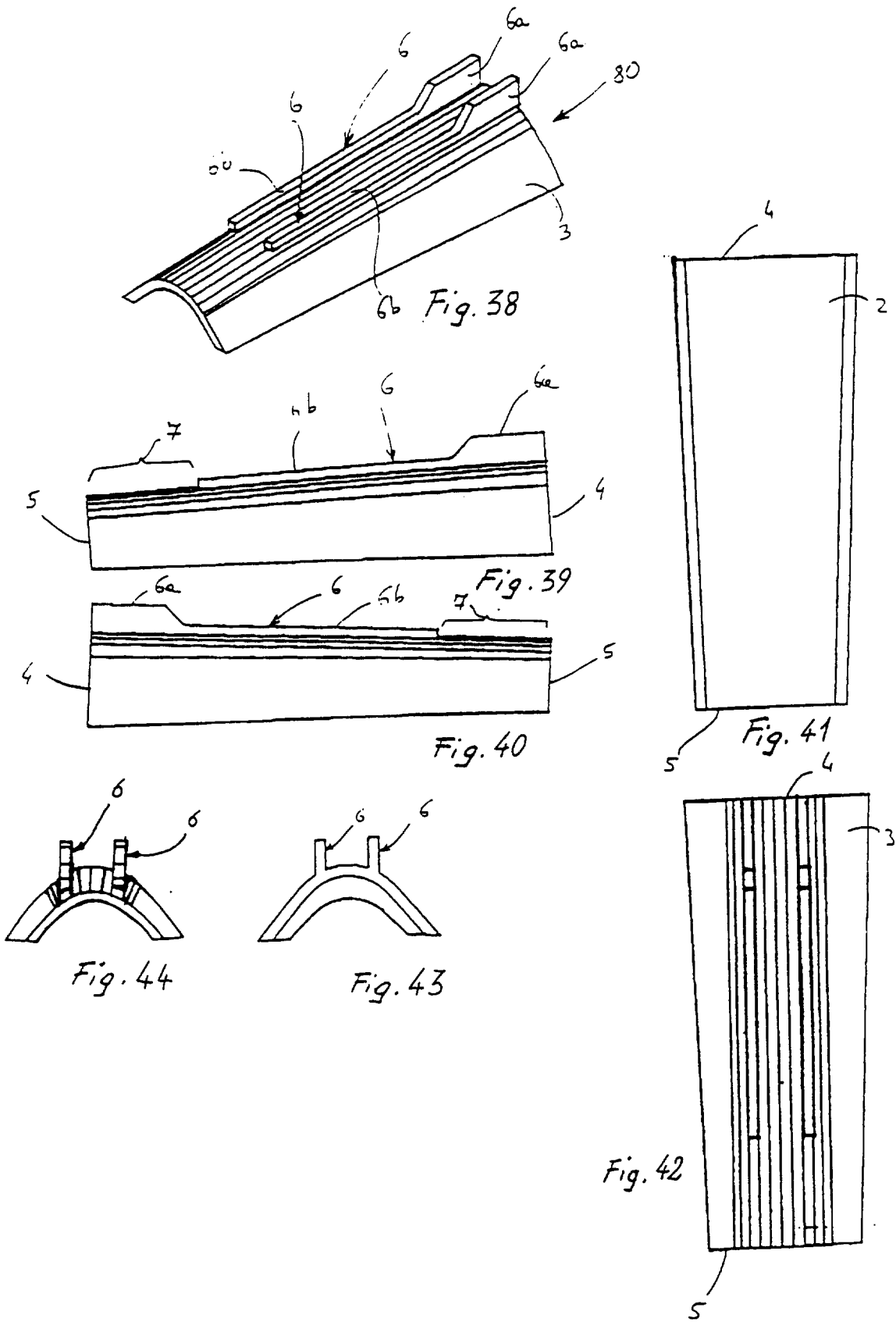
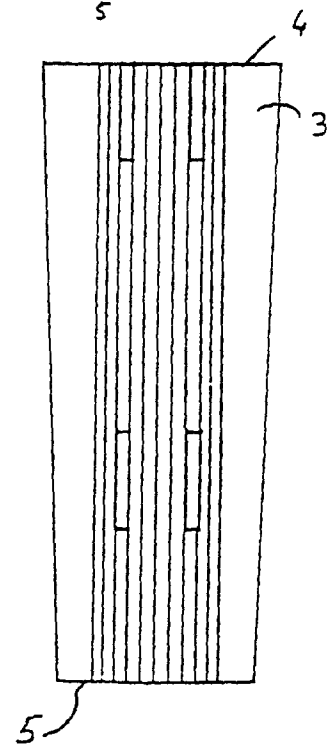
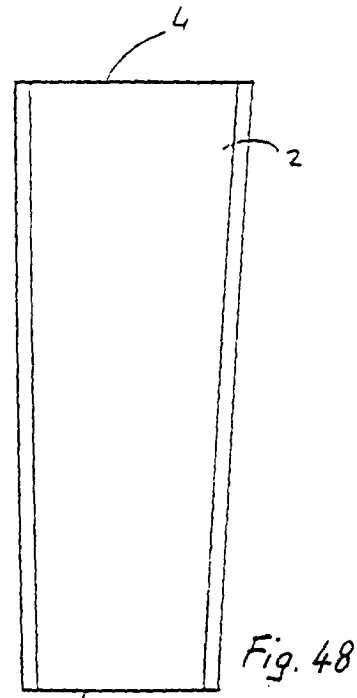
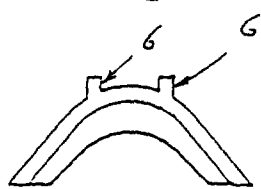
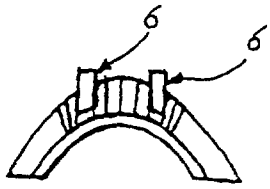
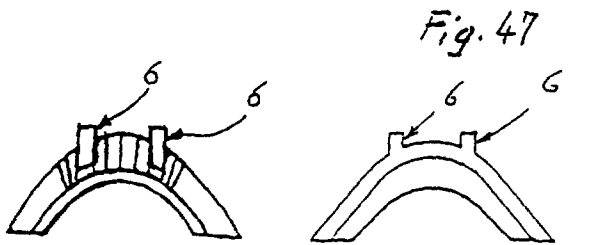
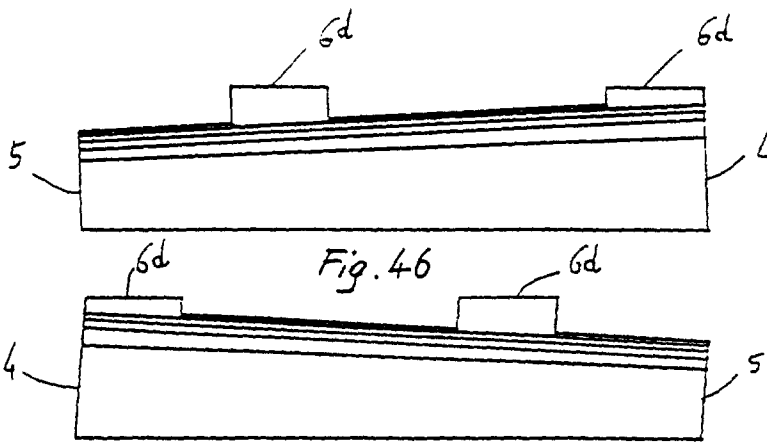
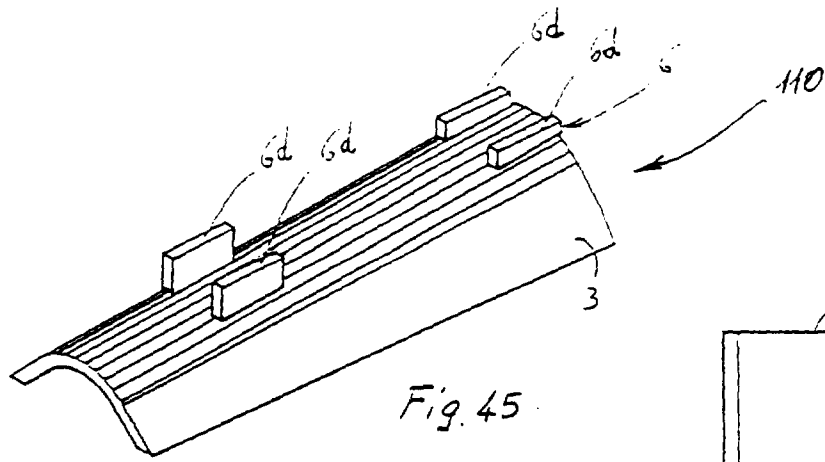

Fig. 35





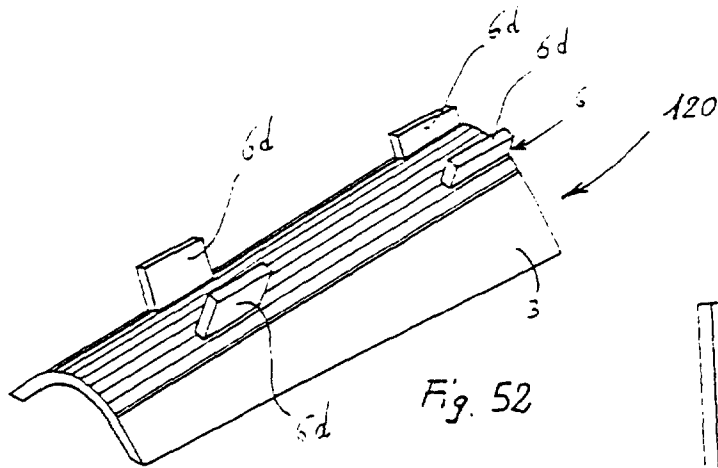

Fig. 52

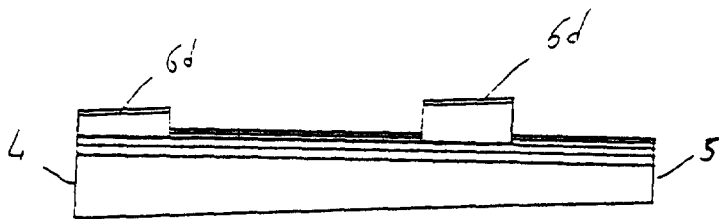

Fig. 53

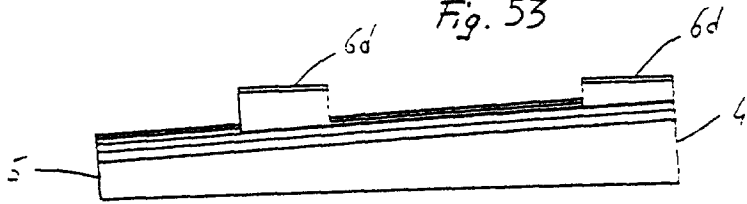

Fig. 54

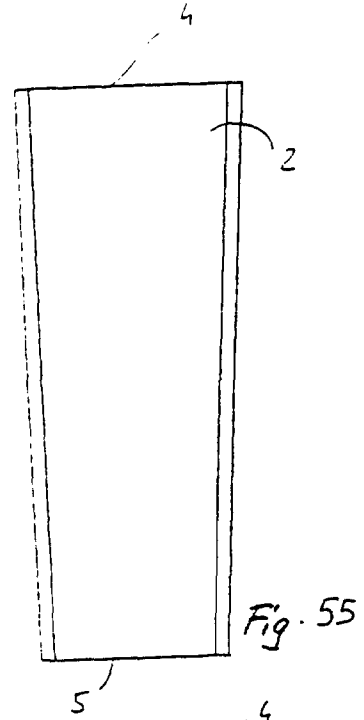

Fig. 55

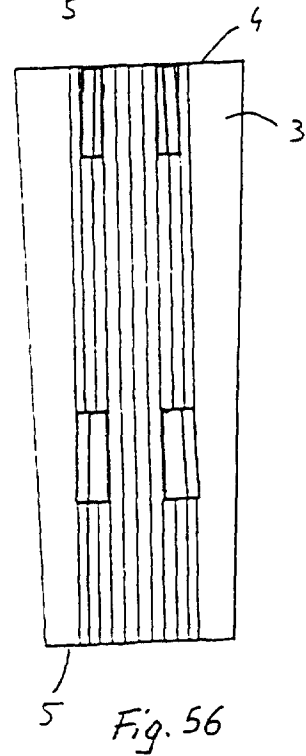

Fig. 56

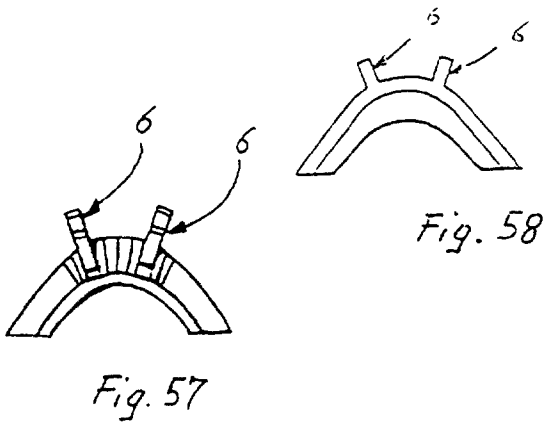

Fig. 57

Fig. 58

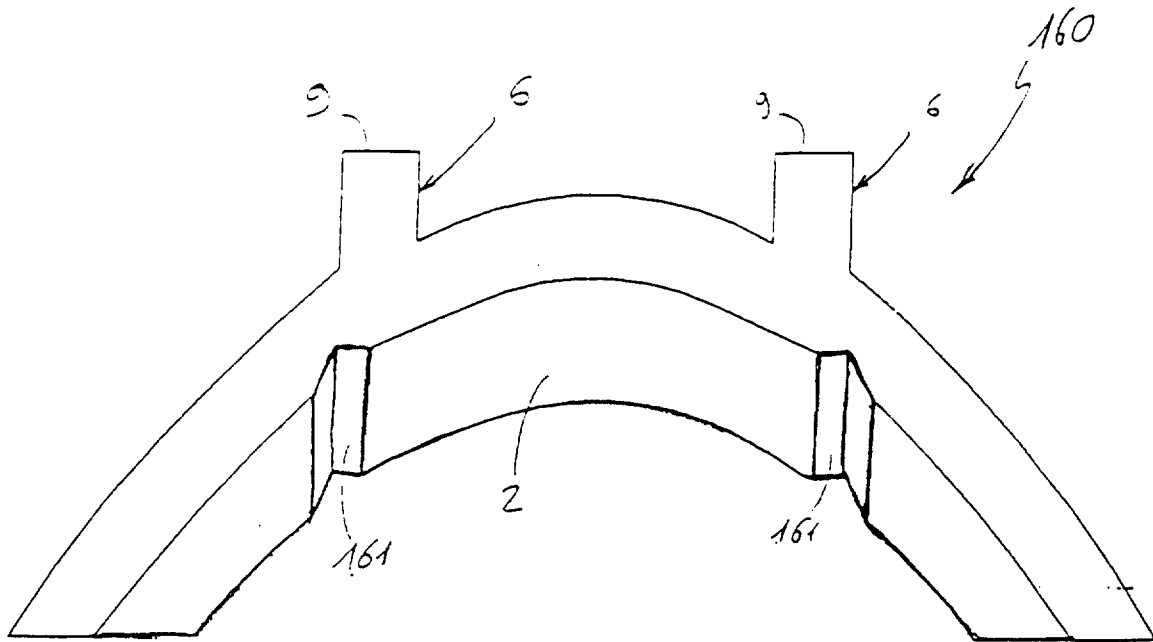

Fig. 60

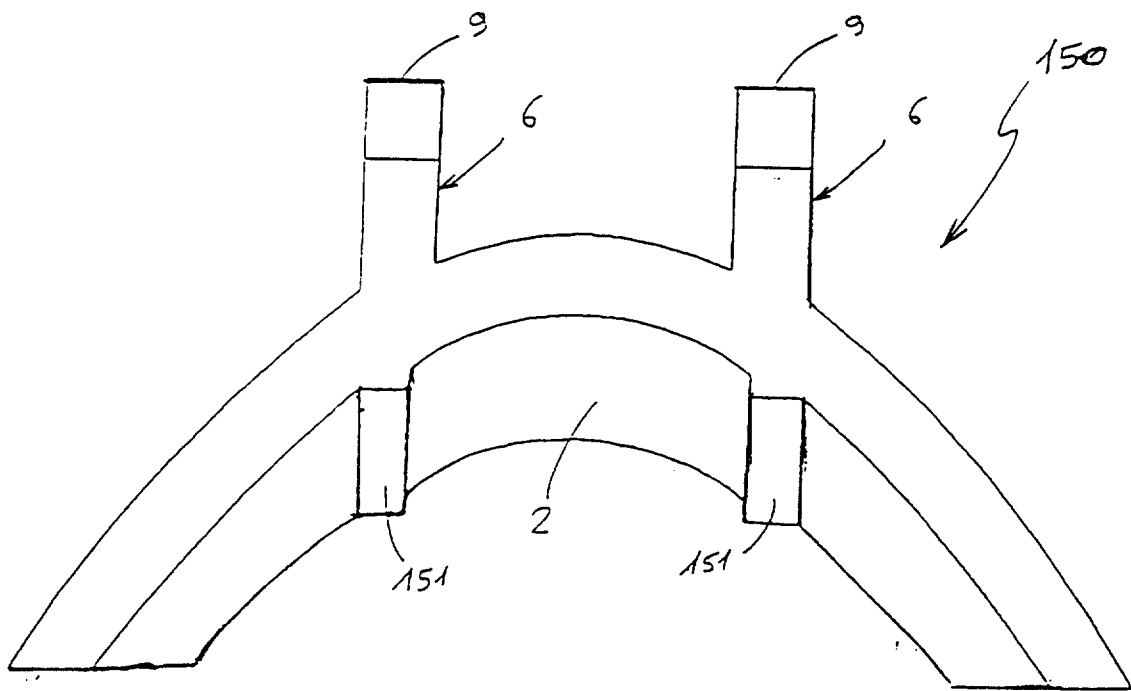

Fig. 59