

(19) World Intellectual Property
Organization
International Bureau



(43) International Publication Date
7 October 2004 (07.10.2004)

PCT

(10) International Publication Number
WO 2004/086529 A1

- (51) International Patent Classification⁷: **H01L 51/20**, 27/15
- (21) International Application Number: PCT/GB2004/001270
- (22) International Filing Date: 23 March 2004 (23.03.2004)
- (25) Filing Language: English
- (26) Publication Language: English
- (30) Priority Data: 0306721.2 24 March 2003 (24.03.2003) GB
- (71) Applicant (for all designated States except US): **MICROEMISSIVE DISPLAYS LIMITED** [GB/GB]; Scottish Microelectronics Centre, The King's Buildings, West Mains Road, Edinburgh., EH9 3JF (GB).
- (72) Inventors; and
- (75) Inventors/Applicants (for US only): **BUCKLEY, Alastair, Robert** [GB/GB]; Flat 2F2, 92 Montpelier Park, Edinburgh., EH10 4NG (GB). **BODAMMER, Georg, Karl, Hermann** [DE/GB]; 8b Gordon Terrace, Edinburgh EH16 5QL (GB). **WHITELEGG, Stephen, Andrew** [GB/GB]; 7 Comiston Court, 121 Comiston Drive, Edinburgh EH10 5QU (GB).
- (74) Agent: **HANSON, William, Bennett**; JY & GW Johnson, Kingsbourne House, 229-231 High Holborn, London WC1V 7DP (GB).
- (81) Designated States (unless otherwise indicated, for every kind of national protection available): AE, AG, AL, AM, AT, AU, AZ, BA, BB, BG, BR, BW, BY, BZ, CA, CH, CN, CO, CR, CU, CZ, DE, DK, DM, DZ, EC, EE, EG, ES, FI, GB, GD, GE, GH, GM, HR, HU, ID, IL, IN, IS, JP, KE, KG, KP, KR, KZ, LC, LK, LR, LS, LT, LU, LV, MA, MD, MG, MK, MN, MW, MX, MZ, NA, NI, NO, NZ, OM, PG, PH, PL, PT, RO, RU, SC, SD, SE, SG, SK, SL, SY, TJ, TM, TN, TR, TT, TZ, UA, UG, US, UZ, VC, VN, YU, ZA, ZM, ZW.
- (84) Designated States (unless otherwise indicated, for every kind of regional protection available): ARIPO (BW, GH, GM, KE, LS, MW, MZ, SD, SL, SZ, TZ, UG, ZM, ZW), Eurasian (AM, AZ, BY, KG, KZ, MD, RU, TJ, TM), European (AT, BE, BG, CH, CY, CZ, DE, DK, EE, ES, FI, FR, GB, GR, HU, IE, IT, LU, MC, NL, PL, PT, RO, SE, SI, SK, TR), OAPI (BF, BJ, CF, CG, CI, CM, GA, GN, GQ, GW, ML, MR, NE, SN, TD, TG).
- Published:**
- with international search report
 - before the expiration of the time limit for amending the claims and to be republished in the event of receipt of amendments
- For two-letter codes and other abbreviations, refer to the "Guidance Notes on Codes and Abbreviations" appearing at the beginning of each regular issue of the PCT Gazette.

(54) Title: METHOD OF FORMING A SEMICONDUCTOR DEVICE

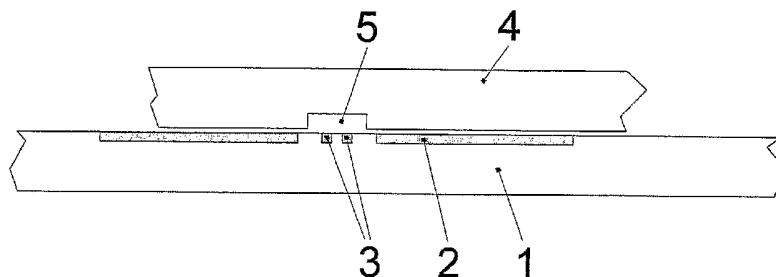

(57) Abstract: A method of forming a semiconductor device from a semiconductor substrate (1) comprising circuitry (2) and terminal means (3) for establishing electrical connection to the circuitry; and a sheet (4) for forming a further layer of the device, the sheet comprising at least one groove (5). Adhesive is applied to at least one of the substrate (1) and the sheet (4); the substrate and the sheet are then aligned in a position such that the groove (5) faces the terminal means (3); and the substrate and the sheet are then attached together by means of the adhesive.

WO 2004/086529 A1

METHOD OF FORMING A SEMICONDUCTOR DEVICE

Background to the Invention

This invention relates to a method of forming a semiconductor device
5 comprising assembling at least two layers.

The invention is particularly, but not exclusively, applicable to forming an optoelectronic device from a semiconducting substrate incorporating active circuitry (e.g. a CMOS - complementary metal-oxide-semiconductor - wafer)
10 and monochrome OLED (organic light emitting diode pixels) and a further translucent layer, for example of glass, comprising color filters providing a color device. Such a device is described in US-A1-20010052752.

A plurality of OLED arrays is formed on a single substrate. The substrate
15 comprises metal bond pads around the edges of each array for establishing electrical connections to the circuitry of the array. A convenient method of attaching the translucent filter layer to the substrate would be to use an adhesive such as an ultraviolet-curable epoxy adhesive. After attaching the filter layer to the substrate, the resulting assembly is singulated by cutting to
20 obtain individual OLED devices.

However, excess adhesive would remain on the bond pads and must be removed using chemical cleaning agents. The cleaning process would be
25 difficult and the agents could damage the encapsulation of the device.

Summary of the Invention

With the aim of alleviating the above-mentioned disadvantages, from a first aspect, the present invention provides a method of forming a semiconductor device comprising providing a semiconductor substrate comprising circuitry
30 and terminal means for establishing electrical connection to the circuitry;

providing a sheet for forming a further layer of the device, the sheet comprising at least one groove; applying adhesive to at least one of said substrate and said sheet; and aligning said substrate and said sheet in a position such that said at least one groove faces said terminal means and
5 attaching said substrate and said sheet together by means of said adhesive in said position. The adhesive may be applied solely to said sheet.

The terminal means may comprise a plurality of bond pads. In a method of making an OLED device according to the invention, the semiconductor
10 substrate comprises at least one array of OLEDs. The further layer may comprise a translucent layer, e.g. of glass, bearing filters, such as color filters.

In a particular embodiment of the invention the circuitry comprises a plurality of discrete circuit means each having terminal means at at least one
15 edge thereof, and after attachment of the substrate to the surface said substrate and sheet are singulated by severing said sheet at the at least one groove to form a plurality of devices each comprising one of said circuit means. There may, for example, be a plurality of parallel grooves in the sheet and there may also be a further set of parallel grooves intersecting said
20 plurality of parallel grooves at right angles, devices being contained in rectangular portions of the substrate delimited by sections of four intersecting grooves when the sheet and the substrate are attached. In this embodiment of the invention each circuit means may have terminal means on all four edges of said rectangular portion. The adhesive may be applied
25 to the entire surface of the sheet, which surface is to be attached to the substrate, for example by spraying.

In an alternative embodiment, each circuit means has terminal means on only one edge thereof. In this embodiment the sheet may be severed along
30 lines offset from lines along which the substrate is severed, said lines in said

substrate and said lines in said sheet being aligned with said grooves but spaced from each other across the width of said grooves. This avoids the need to remove sections of the sheet. The adhesive may be applied to parts only of the sheet, for example in continuous lines or lines of dots parallel to
5 the grooves.

From a second aspect, the present invention provides a semiconductor device assembly comprising a semiconductor substrate comprising circuitry and terminal means for establishing electrical connection to the circuitry; and
10 a sheet attached to the substrate by means of adhesive and forming a further layer of the device, the sheet comprising at least one groove facing and aligned with said terminal means.

The terminal means may comprise a plurality of bond pads. In an OLED
15 device assembly according to the invention, the semiconductor substrate comprises at least one array of OLEDs. The further layer may comprise a translucent layer, e.g. of glass, bearing filters, such as color filters.

In a particular embodiment of the invention the circuitry comprises a
20 plurality of discrete circuit means each having terminal means at least one edge thereof. There may, for example, be a plurality of parallel grooves in the sheet and there may also be a further set of parallel grooves intersecting said plurality of parallel grooves at right angles, devices being contained in rectangular portions of the substrate delimited by sections of four
25 intersecting grooves when the sheet and the substrate are attached. In this embodiment of the invention each circuit means may have terminal means on all four edges of said rectangular portion.

In an alternative embodiment, each circuit means has terminal means on
30 only one edge thereof. In this embodiment the sheet may comprise sheet

channels for severing the sheet, offset from substrate channels along which the substrate is to be severed, said channels in said substrate and said channels in said sheet being aligned with said grooves but spaced from each other across the width of said grooves.

5

From a third aspect, the invention provides an optoelectronic device made according to the alternative embodiment of the inventive method defined above and comprising a semiconductor substrate comprising circuitry, light emitting elements and terminal means for establishing electrical connection to the circuitry; and a sheet attached to the substrate by means of adhesive and forming a further layer of the device, the sheet having a portion extending beyond the substrate, said portion having been formed during the step of severing the sheet along lines offset from lines along which the substrate is severed.

10
15

The terminal means may comprise a plurality of bond pads. In an OLED device according to the invention, the semiconductor substrate comprises at least one array of OLEDs. The further layer may comprise a translucent layer, e.g. of glass, bearing filters, such as color filters.

20

Brief Description of the Drawings

Particular embodiments of the invention will now be described, by way of example only, with reference to the accompanying drawings, in which:

25 Figure 1 is a schematic fragmentary view of a substrate for use in the invention;

Figure 2 is a schematic fragmentary view of a sheet of glass for attaching to the substrate of Figure 1;

30

Figure 3 is a schematic transverse section through an assembly formed from the substrate of Figure 1 and the sheet of Figure 2;

Figure 4 is a schematic transverse section through an alternative assembly;
5 and

Figure 5 shows the assembly of Figure 4 after singulation.

Detailed Description of Particular Embodiments

10 Figure 1 shows part of a substrate 1 comprising a CMOS wafer bearing a number of monochrome OLED arrays 2 which have been fabricated on the active circuitry. Each array is rectangular and has bond pads 3 along all four sides. In Figure 3 each trapezium denotes a line of bond pads, connections between the bond pads 3 and the OLED arrays 2 being omitted for clarity.
15 In addition to the organic light emitting diodes, the substrate comprises further layers such as encapsulating and electrode layers.

Figure 2 shows part of a glass plate 4 for attaching to the substrate of Figure 1. A crisscross network of grooves 5, having a depth of e.g. 0.2 mm and
20 corresponding to the locations of the bond pads 3 of the substrate 1 has been etched in the plate 4. The plate bears color filters (not shown) for defining colored pixels of an optoelectronic device.

A transparent UV-curable epoxy adhesive 6 is sprayed over the entire surface
25 of the plate 4 including the grooves 5, in a layer of uniform thickness (e.g. 5 μm). The plate 4 and the substrate 1 are then assembled as shown in Figure 3. Since the grooves 5 are aligned with the bond pads 3, no adhesive contacts the latter.

The assembly of Figure 3 is singulated preferably by sawing through the substrate 1 at the location of the scribe channels between the bond pads 3 of adjacent devices, and by sawing through the plate 4 at both edges of each groove 5, removing the glass above the groove. To prevent damage the saw cuts may be terminated e.g. 50 μm from the interface between the substrate 1 and the plate 4, the assembly then being broken at the saw cuts.

Figure 4 shows an alternative assembly in which OLED arrays 2' of substrate 1' have rows of bond pads 3' along one side only.

10

Saw cuts 6 are made in glass plate 4 at only one edge of each of the grooves 5. These saw cuts are offset, e.g. by 1.4 mm, from cuts 7 in substrate 1'. The substrate 1' and the plate 4 are broken at the saw cuts 7, 6 respectively to give the singulated devices shown in Figure 5. In this embodiment it is not necessary to remove sections of glass from the plate.

15

As an alternative to spraying adhesive over the entire surface of the plate 4, adhesive could be applied to the plate in continuous lines or lines of dots, parallel to the grooves 5, for example using a robot. This is particularly appropriate in the embodiment shown in Figures 4 and 5. The adhesive spreads when the plate 4 is pressed against the substrate 1', but flows along the inner surface of the grooves 5 rather than on to the bond pads 3', due to the nature of the surface of the glass.

20

All forms of the verb "to comprise" used in this specification have the meaning "to consist of or include".

25

CLAIMS

1. A method of forming a semiconductor device comprising providing a semiconductor substrate comprising circuitry and terminal means for establishing electrical connection to the circuitry; providing a sheet for forming a further layer of the device, the sheet comprising at least one groove; applying adhesive to at least one of said substrate and said sheet; and aligning said substrate and said sheet in a position such that said at least one groove faces said terminal means and attaching said substrate and said sheet together by means of said adhesive in said position.
2. A method according to claim 1, wherein the adhesive is applied solely to said sheet.
3. A method according to claim 1 or 2 wherein the terminal means comprises a plurality of bond pads.
4. A method according to claim 1, 2 or 3, wherein the semiconductor substrate comprises at least one array of organic light emitting diodes.
5. A method according to claim 4, wherein the further layer comprises a translucent layer.
6. A method according to claim 5, wherein the translucent layer is of glass.
7. A method according to claim 5 or 6, wherein the translucent layer bears color filters.

8. A method according to any preceding claim, wherein the circuitry comprises a plurality of discrete circuit means each having terminal means at at least one edge thereof, and after attachment of the substrate to the surface said substrate and sheet are singulated by severing said sheet at the at least
5 one groove to form a plurality of devices each comprising one of said circuit means.
9. A method according to claim 8, wherein the sheet comprises a plurality of parallel grooves and a further set of parallel grooves intersecting
10 said plurality of parallel grooves at right angles, devices being contained in rectangular portions of the substrate delimited by sections of four intersecting grooves when the sheet and the substrate are attached.
10. A method according to claim 9, wherein each circuit means has
15 terminal means on all four edges of said rectangular portion.
11. A method according to any preceding claim, wherein the adhesive is applied to the entire surface of the sheet, which surface is to be attached to the substrate.
20
12. A method according to claim 8, wherein each circuit means has terminal means on only one edge thereof.
13. A method according to claim 12, wherein the sheet is severed along
25 lines offset from lines along which the substrate is severed, said lines in said substrate and said lines in said sheet being aligned with said grooves but spaced from each other across the width of said grooves.
14. A method according to claim 12 or 13, wherein the adhesive is applied
30 to parts only of the sheet.

15. A method according to claim 14, wherein the adhesive is applied to the sheet in lines parallel to the grooves.

5 16. A semiconductor device assembly comprising a semiconductor substrate comprising circuitry and terminal means for establishing electrical connection to the circuitry; and a sheet attached to the substrate by means of adhesive and forming a further layer of the device, the sheet comprising at least one groove facing and aligned with said terminal means.

10

17. A semiconductor device assembly according to claim 16, wherein the terminal means comprise a plurality of bond pads.

18. A semiconductor device assembly according to claim 16 or 17,
15 wherein the semiconductor substrate comprises at least one array of organic light emitting diodes.

19. An assembly according to claim 18, wherein the further layer comprises a translucent layer.

20

20. An assembly according to claim 19, wherein the translucent layer is of glass.

21. An assembly according to claim 19 or 20, wherein the translucent
25 layer bears color filters.

22. An assembly according to any one of claims 16 to 20, wherein the circuitry comprises a plurality of discrete circuit means each having terminal means at least one edge thereof.

30

23. An assembly according to claim 22, wherein the sheet comprises a plurality of parallel grooves and a further set of parallel grooves intersecting said plurality of parallel grooves at right angles, devices being contained in rectangular portions of the substrate delimited by sections of four
5 intersecting grooves when the sheet and the substrate are attached.

24. An assembly according to claim 23, wherein each circuit means has terminal means on all four edges of said rectangular portion.

10 25. An assembly according to claim 22, wherein each circuit means has terminal means on only one edge thereof.

26. An assembly according to claim 25, wherein the sheet comprises sheet channels for severing the sheet, offset from substrate channels along which
15 the substrate is to be severed, said channels in said substrate and said channels in said sheet being aligned with said grooves but spaced from each other across the width of said grooves.

27. An optoelectronic device made according to the method of any one of
20 claims 13, 14 and 15, the device comprising a semiconductor substrate comprising circuitry, light emitting elements and terminal means for establishing electrical connection to the circuitry; and a sheet attached to the substrate by means of adhesive and forming a further layer of the device, the sheet having a portion extending beyond the substrate, said portion having
25 been formed during the step of severing the sheet along lines offset from lines along which the substrate is severed.

28. A device according to claim 27, wherein the terminal means comprise a plurality of bond pads.

29. A device according to claim 28, wherein the semiconductor substrate comprises at least one array of organic light emitting diodes.
30. A device according to claim 29, wherein the further layer comprises a
5 translucent layer.
31. A device according to claim 30, wherein the translucent layer is of glass.
- 10 32. A device according to claim 30 or 31, wherein the translucent layer bears color filters.

1/3

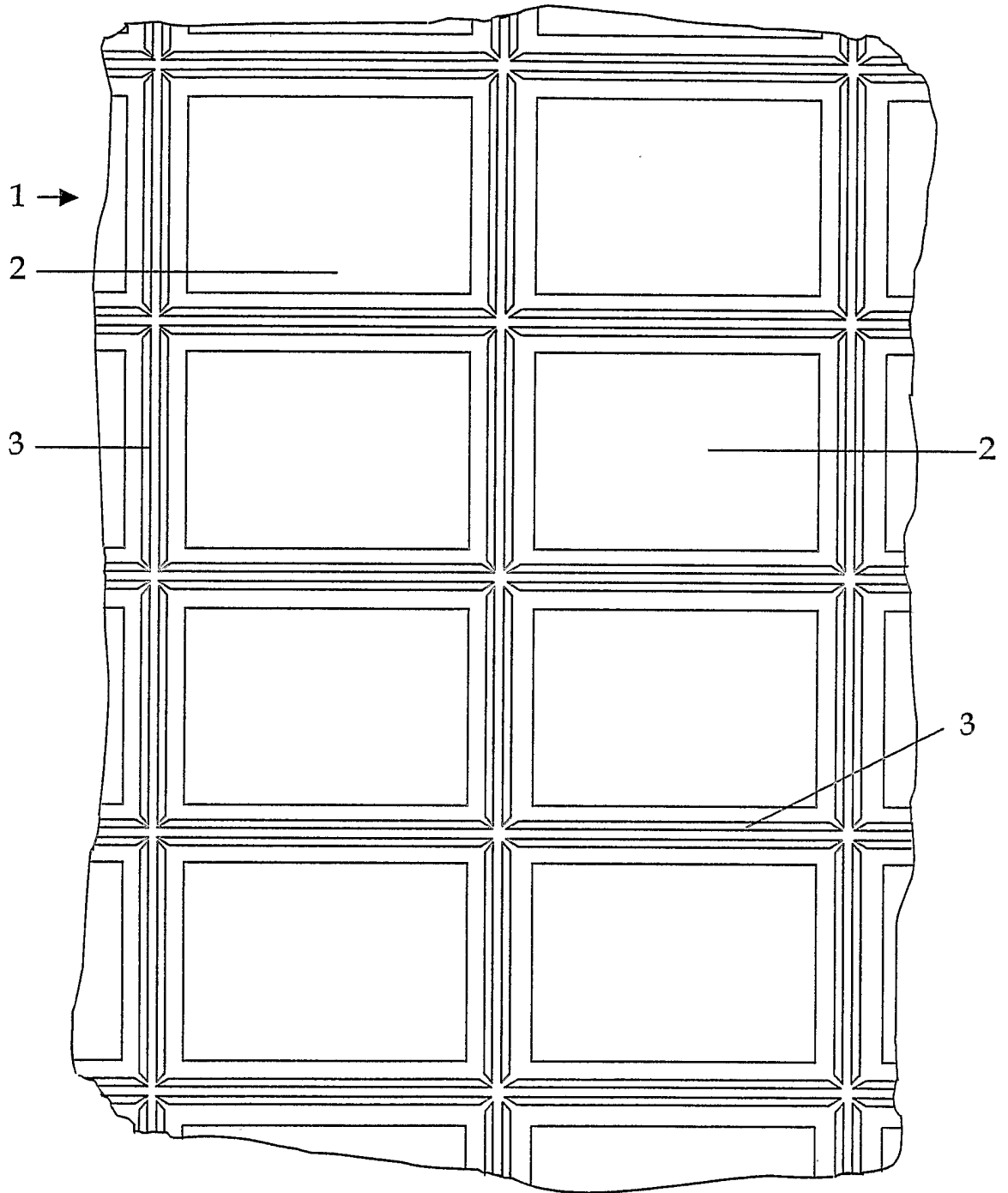

Fig. 1 (Prior Art)

2/3

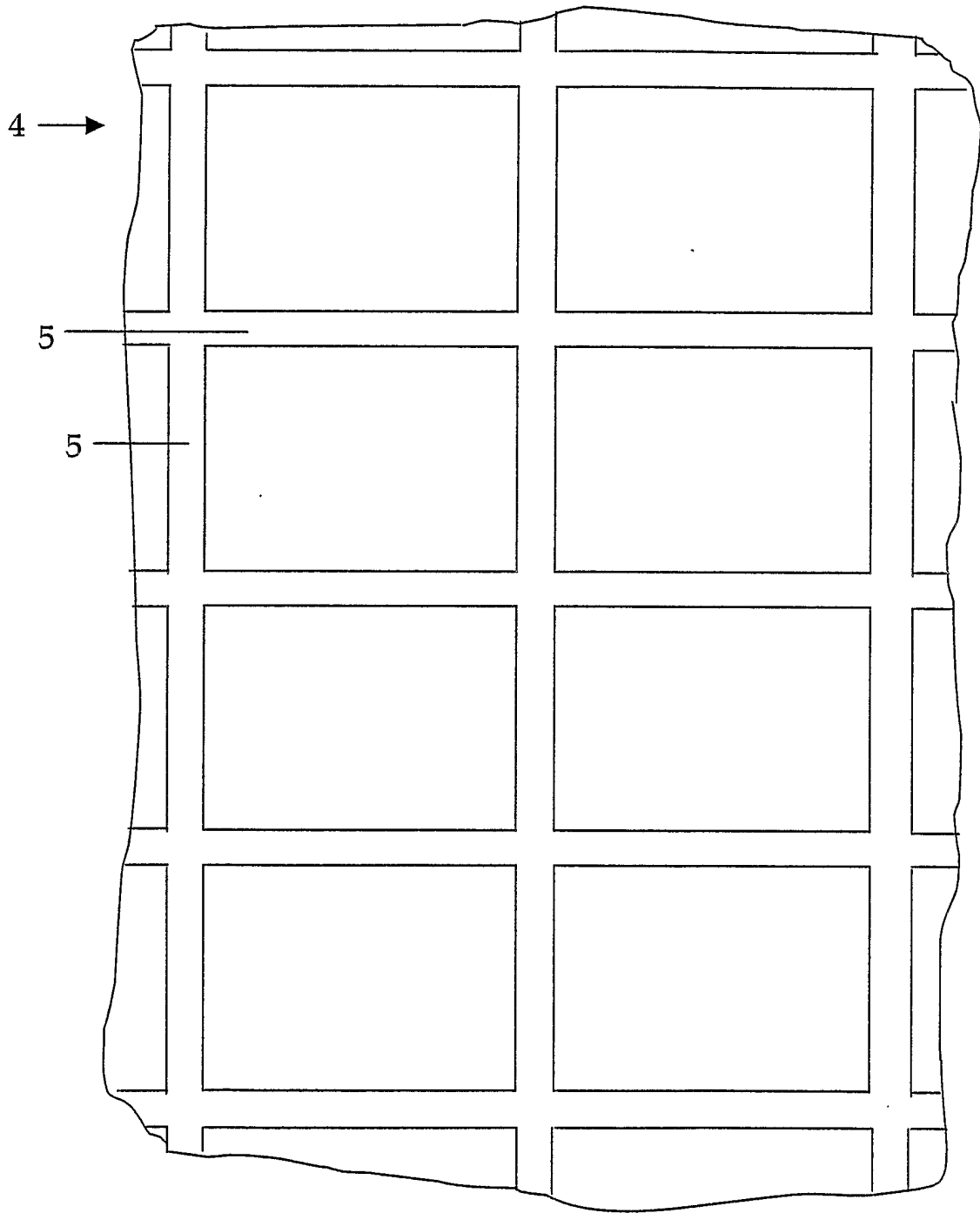

Fig. 2

3/3

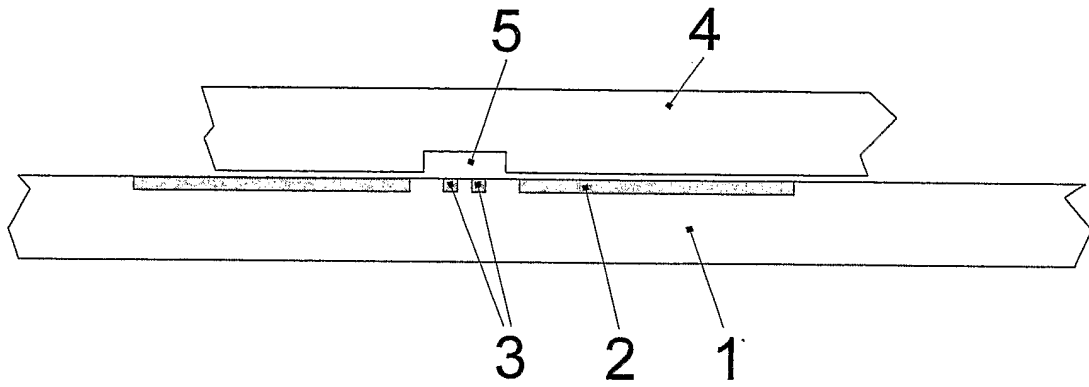

Fig. 3

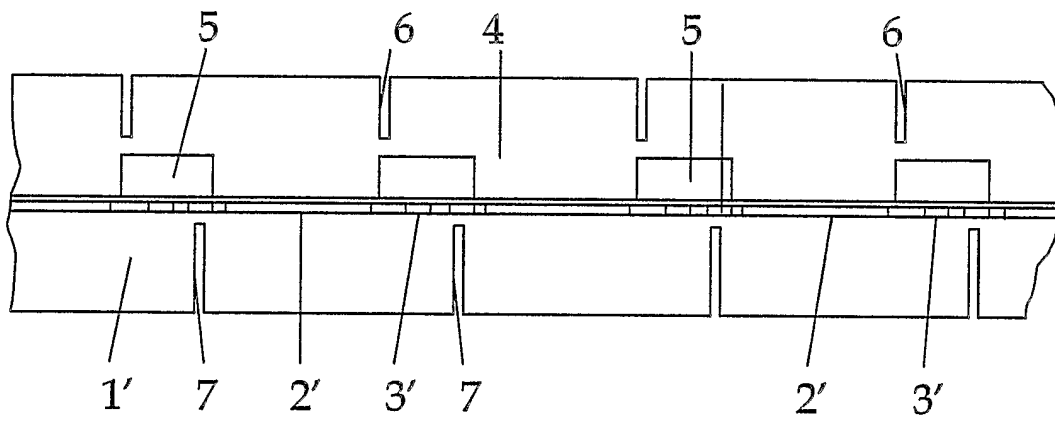

Fig. 4

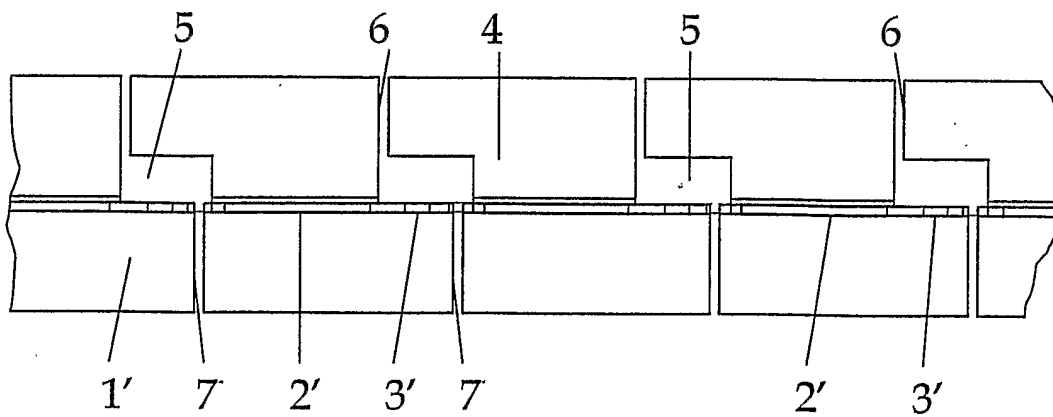

Fig. 5

INTERNATIONAL SEARCH REPORT

International Application No
PCT/GB2004/001270

A. CLASSIFICATION OF SUBJECT MATTER
IPC 7 H01L51/20 H01L27/15

According to International Patent Classification (IPC) or to both national classification and IPC

B. FIELDS SEARCHED

Minimum documentation searched (classification system followed by classification symbols)
IPC 7 H01L B81C

Documentation searched other than minimum documentation to the extent that such documents are included in the fields searched

Electronic data base consulted during the international search (name of data base and, where practical, search terms used)

EPO-Internal, PAJ

C. DOCUMENTS CONSIDERED TO BE RELEVANT

Category °	Citation of document, with indication, where appropriate, of the relevant passages	Relevant to claim No
X	US 2002/170175 A1 (AIGNER ROBERT ET AL) 21 November 2002 (2002-11-21)	1, 3, 8-10, 12-17, 22-26
Y	figures 1-3 paragraphs '0019!, '0022! - '0024!, '0031!, '0033! column 3, paragraph 51-54 figures 7,9,10	1-11, 16-24, 27-32
	----- -/--	

Further documents are listed in the continuation of box C.

Patent family members are listed in annex.

° Special categories of cited documents :

- *A* document defining the general state of the art which is not considered to be of particular relevance
- *E* earlier document but published on or after the international filing date
- *L* document which may throw doubts on priority claim(s) or which is cited to establish the publication date of another citation or other special reason (as specified)
- *O* document referring to an oral disclosure, use, exhibition or other means
- *P* document published prior to the international filing date but later than the priority date claimed

- *T* later document published after the international filing date or priority date and not in conflict with the application but cited to understand the principle or theory underlying the invention
- *X* document of particular relevance; the claimed invention cannot be considered novel or cannot be considered to involve an inventive step when the document is taken alone
- *Y* document of particular relevance; the claimed invention cannot be considered to involve an inventive step when the document is combined with one or more other such documents, such combination being obvious to a person skilled in the art.
- *&* document member of the same patent family

Date of the actual completion of the international search

10 September 2004

Date of mailing of the international search report

17/09/2004

Name and mailing address of the ISA

European Patent Office, P.B. 5818 Patentlaan 2
NL - 2280 HV Rijswijk
Tel. (+31-70) 340-2040, Tx. 31 651 epo nl,
Fax: (+31-70) 340-3016

Authorized officer

Faou, M

INTERNATIONAL SEARCH REPORT

International Application No

T/GB2004/001270

C.(Continuation) DOCUMENTS CONSIDERED TO BE RELEVANT		
Category °	Citation of document, with indication, where appropriate, of the relevant passages	Relevant to claim No.
Y	PATENT ABSTRACTS OF JAPAN vol. 2003, no. 04, 2 April 2003 (2003-04-02) -& JP 2002 352951 A (TOHOKU PIONEER CORP), 6 December 2002 (2002-12-06) abstract; figures 1-3 -----	2,4-7, 11, 18-21, 27-32
Y	US 5 668 033 A (KANAMORI KATUHIKO ET AL) 16 September 1997 (1997-09-16) columns 1,2,4 - column 6, lines 6-9 figures 16-18 column 9, lines 26-33 - column 13, lines 15-31 -----	1-3, 8-10,16, 17,22-24
A	US 2001/052752 A1 (GHOSH AMALKUMAR P ET AL) 20 December 2001 (2001-12-20) paragraph '0042! paragraph '0032!; figure 5 -----	1-32
A	PATENT ABSTRACTS OF JAPAN vol. 2002, no. 02, 2 April 2002 (2002-04-02) -& JP 2001 297878 A (NIPPON SEIKI CO LTD), 26 October 2001 (2001-10-26) abstract figures 2,4 -----	4-7, 18-21, 27-31
A	US 2002/044124 A1 (ARAI YASUYUKI ET AL) 18 April 2002 (2002-04-18) figures 1,15A,15B paragraphs '0014!, '0097! paragraphs '0214! - '0230! -----	1-32

INTERNATIONAL SEARCH REPORT

Information on patent family members

International Application No

PCT/JP2004/001270

Patent document cited in search report		Publication date	Patent family member(s)	Publication date
US 2002170175	A1	21-11-2002	DE 19962231 A1	12-07-2001
			AT 272845 T	15-08-2004
			DE 50007326 D1	09-09-2004
			WO 0146664 A2	28-06-2001
			EP 1240529 A2	18-09-2002
			JP 2003517946 T	03-06-2003
JP 2002352951	A	06-12-2002	NONE	
US 5668033	A	16-09-1997	JP 8316497 A	29-11-1996
			DE 19619921 A1	05-12-1996
US 2001052752	A1	20-12-2001	AU 5519401 A	07-11-2001
			WO 0182390 A1	01-11-2001
			WO 02071506 A1	12-09-2002
			US 2002003403 A1	10-01-2002
JP 2001297878	A	26-10-2001	NONE	
US 2002044124	A1	18-04-2002	JP 2002108243 A	10-04-2002
			TW 538246 B	21-06-2003