

[54] CARRIER FOR BABY BOTTLES

D. 234,980 4/1975 Tomlin et al. D24/48
2,733,883 2/1956 Gourley 248/105
2,865,669 12/1958 Linthicum D9/344 X

[76] Inventor: Edmund Smith, P.O. Box 754,
Intervale, N.H. 03485

Primary Examiner—A. Hugo Word
Assistant Examiner—Stella M. Reid
Attorney, Agent, or Firm—Jerry T. Kearns

[**] Term: 14 Years

[21] Appl. No.: 176,405

[57] CLAIM

[22] Filed: Mar. 31, 1988

The ornamental design for a carrier for baby bottles, as shown and described.

[52] U.S. Cl. D9/344

[58] Field of Search D24/48; 248/102-107;
D8/373, 349; D34/43; D9/344; 206/198, 145,
159; 220/85 H, 94 R, 94 B, 96

DESCRIPTION

[56] References Cited

U.S. PATENT DOCUMENTS

D. 169,318 4/1953 Kelley et al. D9/344
D. 202,305 9/1965 Struble D9/344
D. 211,435 6/1968 Kausen et al. D24/48

FIG. 1 is a front elevational view of a carrier for baby bottles showing my new design;
FIG. 2 is a rear elevational view thereof;
FIG. 3 is a left side elevational view thereof;
FIG. 4 is a right side elevational view thereof;
FIG. 5 is a top plan view thereof; and,
FIG. 6 is a bottom plan view thereof.

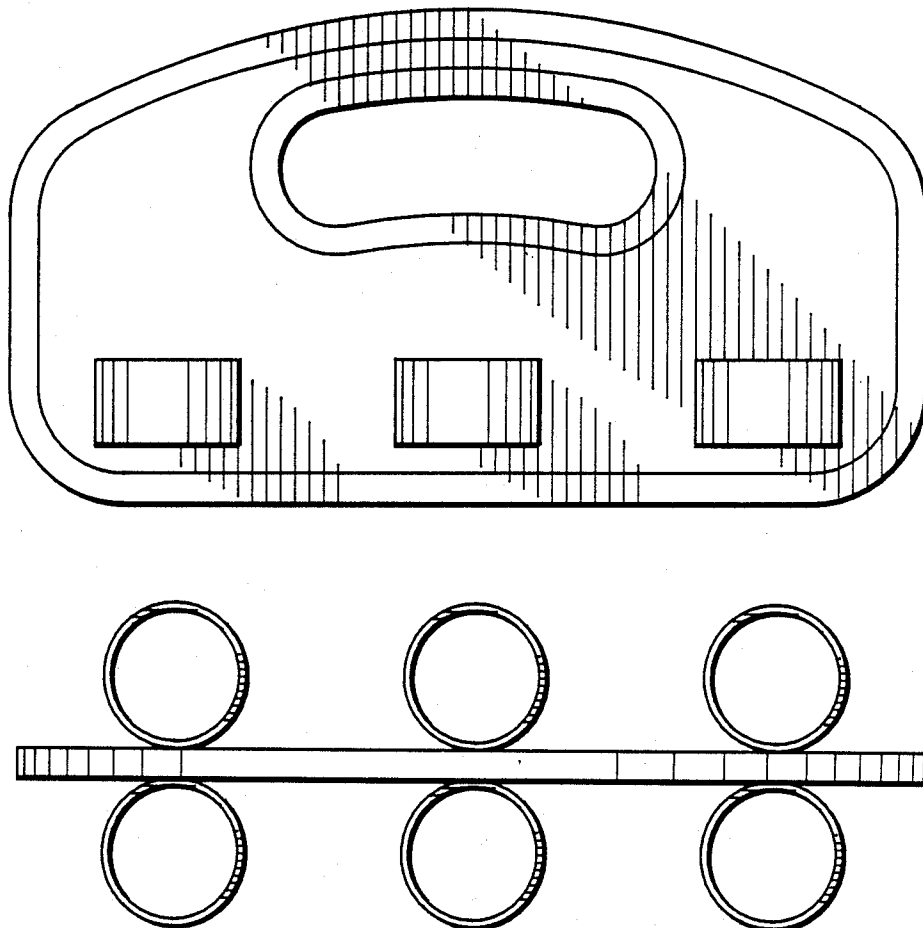

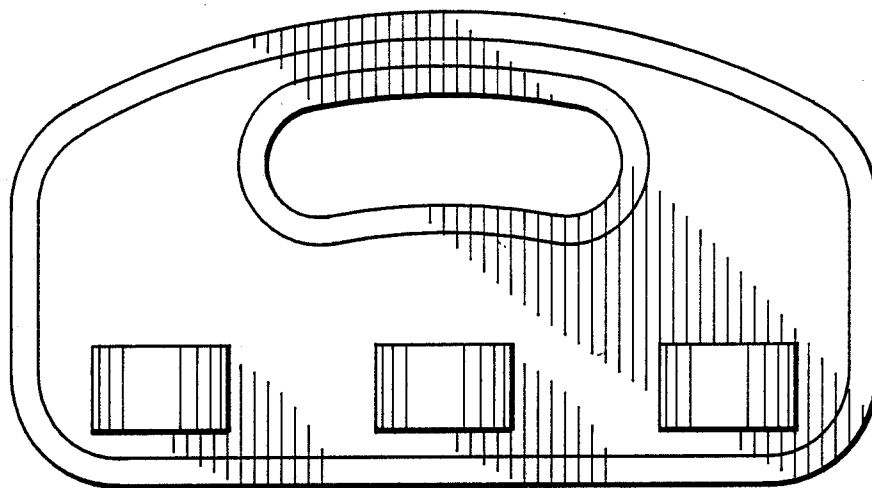

Fig. 1

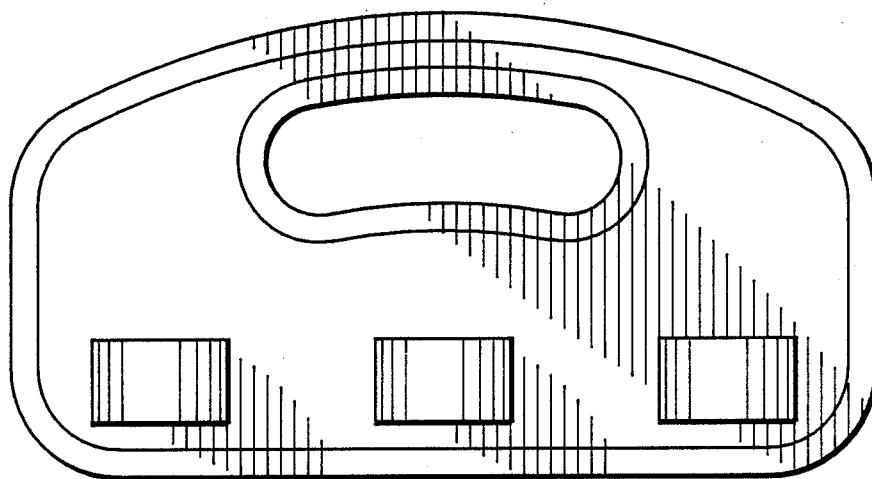

Fig. 2

