



(12) **DEMANDE DE BREVET CANADIEN
CANADIAN PATENT APPLICATION**

(13) **A1**

(86) Date de dépôt PCT/PCT Filing Date: 2019/09/09
(87) Date publication PCT/PCT Publication Date: 2020/03/19
(85) Entrée phase nationale/National Entry: 2021/01/20
(86) N° demande PCT/PCT Application No.: IB 2019/057579
(87) N° publication PCT/PCT Publication No.: 2020/053736
(30) Priorité/Priority: 2018/09/13 (IB PCT/IB2018/056998)

(51) Cl.Int./Int.Cl. *B23K 11/11* (2006.01)
(71) Demandeur/Applicant:
ARCELORMITTAL, LU
(72) Inventeurs/Inventors:
MACHADO AMORIM, TIAGO, FR;
BROSSARD, MAXIME, FR;
MICHAUT, STEPHANIE, FR;
HELMER, JEAN-MARIE, FR
(74) Agent: SMART & BIGGAR LLP

(54) Titre : PROCÉDE DE SOUDAGE POUR LA FABRICATION D'UN ENSEMBLE D'AU MOINS 2 SUBSTRATS METALLIQUES
(54) Title: A WELDING METHOD FOR THE MANUFACTURE OF AN ASSEMBLY OF AT LEAST 2 METALLIC SUBSTRATES

Figure 1

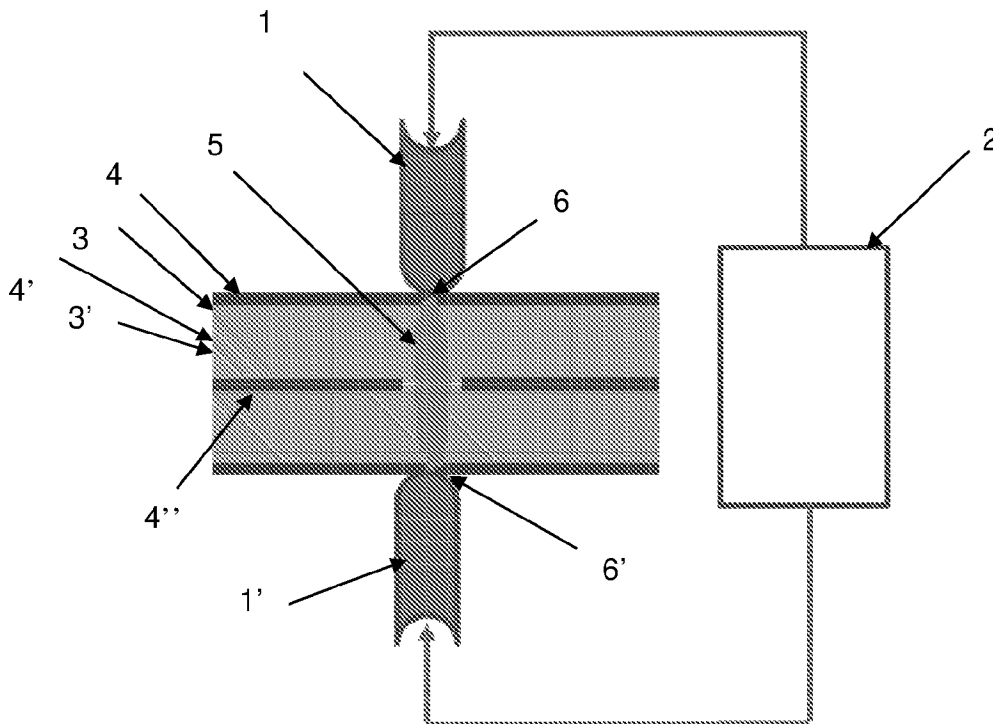

(57) **Abrégé/Abstract:**

The present invention relates to a method for the manufacture of an assembly of at least two metallic substrates spot welded together through at least one spot welded joint, such method comprising two steps, the assembly obtainable according to this method and the use of this assembly for the manufacture of automotive vehicle.

(12) INTERNATIONAL APPLICATION PUBLISHED UNDER THE PATENT COOPERATION TREATY (PCT)

(19) World Intellectual Property
Organization
International Bureau

(43) International Publication Date
19 March 2020 (19.03.2020)



(10) International Publication Number
WO 2020/053736 A1

(51) International Patent Classification:

B23K 11/11 (2006.01) *B23K 103/04* (2006.01)
B23K 101/34 (2006.01) *B23K 101/00* (2006.01)

(21) International Application Number:

PCT/IB2019/057579

(22) International Filing Date:

09 September 2019 (09.09.2019)

(25) Filing Language:

English

(26) Publication Language:

English

(30) Priority Data:

PCT/IB2018/056998

13 September 2018 (13.09.2018) IB

(71) Applicant: **ARCELORMITTAL** [LU/LU]; 24-26, Boulevard d'Avranches, L-1160 LUXEMBOURG (LU).

(72) Inventors: **MACHADO AMORIM, Tiago**; 46 rue du Général De Gaulle, 57050 Longeville Les Metz (FR). **BROSSARD, Maxime**; 61 rue de Tivoli, 57070 Metz (FR). **MICHAUT, Stéphanie**; 57 Lotissement des Linières, 57580 REMILLY (FR). **HELMER, Jean-Marie**; ArcelorMittal Research and Development, Voie Romaine, BP 30320, 57283 Maizières-Lès-Metz (FR).

(74) Agent: **PLAISANT, Sophie**; ArcelorMittal France, Research & Development, Intellectual Property, 6 rue André Campra, 93200 Saint-Denis (FR).

(81) Designated States (unless otherwise indicated, for every kind of national protection available): AE, AG, AL, AM, AO, AT, AU, AZ, BA, BB, BG, BH, BN, BR, BW, BY, BZ, CA, CH, CL, CN, CO, CR, CU, CZ, DE, DJ, DK, DM, DO, DZ, EC, EE, EG, ES, FI, GB, GD, GE, GH, GM, GT, HN, HR, HU, ID, IL, IN, IR, IS, JO, JP, KE, KG, KH, KN, KP, KR, KW, KZ, LA, LC, LK, LR, LS, LU, LY, MA, MD, ME, MG, MK, MN, MW, MX, MY, MZ, NA, NG, NI, NO, NZ, OM, PA, PE, PG, PH, PL, PT, QA, RO, RS, RU, RW, SA, SC, SD, SE, SG, SK, SL, SM, ST, SV, SY, TH, TJ, TM, TN, TR, TT, TZ, UA, UG, US, UZ, VC, VN, ZA, ZM, ZW.

(84) Designated States (unless otherwise indicated, for every kind of regional protection available): ARIPO (BW, GH, GM, KE, LR, LS, MW, MZ, NA, RW, SD, SL, ST, SZ, TZ, UG, ZM, ZW), Eurasian (AM, AZ, BY, KG, KZ, RU, TJ, TM), European (AL, AT, BE, BG, CH, CY, CZ, DE, DK, EE, ES, FI, FR, GB, GR, HR, HU, IE, IS, IT, LT, LU, LV, MC, MK, MT, NL, NO, PL, PT, RO, RS, SE, SI, SK, SM, TR), OAPI (BF, BJ, CF, CG, CI, CM, GA, GN, GQ, GW, KM, ML, MR, NE, SN, TD, TG).

(54) Title: A WELDING METHOD FOR THE MANUFACTURE OF AN ASSEMBLY OF AT LEAST 2 METALLIC SUBSTRATES

Figure 1

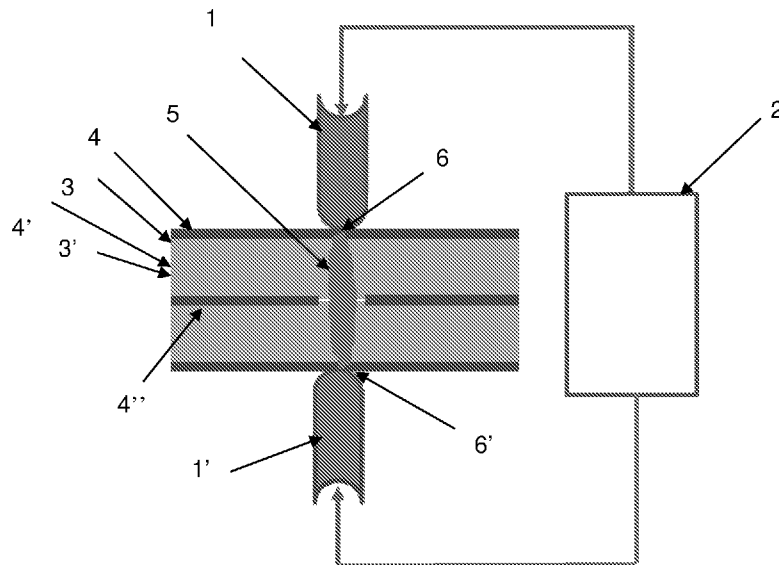

(57) Abstract: The present invention relates to a method for the manufacture of an assembly of at least two metallic substrates spot welded together through at least one spot welded joint, such method comprising two steps, the assembly obtainable according to this method and the use of this assembly for the manufacture of automotive vehicle.

[Continued on next page]



WO 2020/053736 A1

WO 2020/053736 A1 

Published:

— *with international search report (Art. 21(3))*

A welding method for the manufacture of an assembly of at least 2 metallic substrates

5 The present invention relates to a method for the manufacture of an assembly of at least two metallic substrates and the assembly. The invention is particularly well suited for the manufacture of automotive vehicles.

 With a view of saving the weight of vehicles, it is known to use high strength steel sheets to achieve lighter weight vehicle bodies and improve crash safety.
10 Hardened parts are also used notably to reduce the weight of vehicles. Indeed, the tensile strength of these steels is of minimum 1200MPa and can be up to 2500MPa. Hardened parts can be coated with an aluminum-based or zinc-based coating having a good corrosion resistance and thermal properties.

 Usually, the method for the manufacture of a coated hardened part comprises
15 the following steps:

- A) the provision of a steel sheet pre-coated with a metallic coating being conventional coating based on aluminum or zinc,
- B) the cutting of the coated steel sheet to obtain a blank,
- C) the thermal treatment of the blank at a high temperature to obtain a fully
20 austenitic microstructure in the steel,
- D) the transfer of the blank into a press tool,
- E) the hot-forming of the blank to obtain a part,
- F) the cooling of the part obtained at step E) in order to obtain a microstructure in
25 steel being martensitic or martensite-bainitic or made of at least 75% of equiaxed ferrite, from 5 to 20% of martensite and bainite in amount less than or equal to 10%.

 It is generally followed by the welding of two coated hardened parts or one coated hardened part with another metallic substrate. The welding of aluminum or zinc based coated hardened parts is very difficult to realize due to the coating being hard
30 and thick.

 The patent application EP3020499 discloses a resistance spot welding method comprising:

- a pulsation process of clamping a sheet assembly of two or more overlapping steel sheets including at least one high-tensile steel sheet using a pair of welding electrodes that are connected to a spot welding power source employing an inverter direct current method, and performing a plurality of repetitions of current passing and current pass stopping, while pressing the steel sheets with the welding electrodes; and
- a continuous current passing process in which, after the pulsation process, current is passed continuously for a longer period of time than a maximum current passing time of the pulsation process, while pressing the steel sheets with the welding electrodes.

However, this method is only dedicated to hot stamped steel sheets coated with conventional zinc-based-coating and aluminum-based coating. Indeed, in Examples, this method was tested on aluminum coated 1500MPa hot stamped steel sheets, galvanized coated 1500MPa grade hot stamped steel sheet and ZnO skin-treated Al coated 1500MPa grade hot stamped steel sheet. Specific coatings based on aluminum or zinc including other elements are not included in this patent application.

The patent application EP3085485 discloses a resistance spot welding method welding a plurality of steel sheets including a high tensile steel sheet superposed, in which said resistance spot welding method, the conduction system is pulsation conduction using an inverter DC welding power supply, and, in the plurality of current pulses forming the pulsation conduction, at the respective current pulses, the conduction time, the intervals of the current pulses defined as the conduction idle time, and the weld currents applied by the current pulses are variably controlled.

However, this method is dedicated to hot stamped steel sheets comprising on its surface a solid solution of intermetallic compounds and iron by an alloying reaction between a conventional zinc-based (pure Zn, Zn-Fe, Zn-Ni, Zn-Al, Zn-Mg, Zn-Mg-Al, etc.) or a conventional aluminum-based (Al-Si etc.) coating and the steel of the base material. These surfaces are formed with an oxide layer mainly comprised of zinc or aluminum. Further, sometimes the surface of the coating mainly comprised of intermetallic compounds of iron and aluminum is formed with a film mainly comprised of zinc oxide. In Examples, the method was tested on hot stamped steel sheets coated with an alloyed of aluminum coating comprising 9% by weight of Si and Fe and a very small amount of ZnO, and on galvanized coated hot stamped steel sheets. Usually, the native oxide layer of these coatings has a thickness between 10 and 100nm. When

a thin layer of ZnO is deposited on the aluminum based coated hardened part before the austenitization, ZnO and the aluminum-based coating are alloyed. Since a very thin layer of ZnO is deposited on the aluminum-based coating, the oxide native mainly composed of Aluminum is still very thin after austenitization, i.e. 10-100nm, leading to an easy welding. Specific coatings based on aluminum or zinc containing other elements are not included in this patent application.

The patent application GB2468011 discloses a method for applying a current for resistive welding of a plate assembly in which a material of at least one plate is a high-tensile material, the method comprising:

- 10 - a first step of applying a first amperage of a magnitude that softens a surface of a joining location of the high-tensile material, continuously for a first predetermined duration;
- a second step of, when the first predetermined duration has passed, switching an energization amount from the first amperage to a second amperage that causes a nugget to grow at the joining location; and
- 15 - a third step of applying the second amperage continuously for a second predetermined duration.

This method is dedicated to a high-tensile material or a hot-stamped material. The hot-stamped material can be coated with a plating layer. However, the nature of the plating layer is not specified. Additionally, in the first step, low amperage is applied to soften the surface of a joining location and the second step, high amperage is applied to cause the growth of the nugget at the joining location of the high tensile materials. Nevertheless, the low amperage in the first step is not sufficient for the welding of specific coated hot stamped parts wherein the coatings comprising other elements than zinc or aluminum.

Recently, new coatings have been developed for hot formed steel sheets. The patent application WO2017017521 discloses a phosphatable hardened part coated with an alloyed coating comprising from 0.4 to 20.0% by weight of zinc, from 1.0 to 3.5% by weight of silicon, optionally from 1.0 to 4.0 by weight of magnesium wherein the ratio Zn/Si is between 3.2 and 8.0. The patent application WO2017/017514 discloses a hardened part coated with an alloyed coating comprising from 2.0 to 24.0% by weight of zinc, from 1.1 to 7.0% by weight of silicon and optionally from 1.1 to 8.0% of magnesium, the balance being aluminum wherein the ratio Al/Zn is above 2.9 for improving the liquid metal embrittlement (LME) resistance. The patent application

WO2017/017513 discloses a sacrificial steel sheet coated with a coating comprising from 2.0 and 24% by weight of zinc, from 7.1 to 12.0% of silicon, optionally from 1.1 to 8.0% by weight of magnesium, the balance being aluminum wherein the ratio Al/Zn is above 2.9 and the coated sacrificial hardened part obtained after the method of press
5 hardening. These specific coatings have a native oxide layer of a micrometric thickness. Because of the thickness and the hardness of the native oxide layer, these coatings are very difficult to weld.

Nevertheless, none method has been developed to weld these specific coated hardened parts.

10 Thus, the objective of the present invention is to provide an easy to implement welding method for the manufacture of hardened parts coated with specific coatings based on aluminum or zinc recently developed. In particular for the production lines, the objective is to obtain a welding range for such specific coated hardened parts being equal or above 1kA.

15 This objective is achieved by providing a welding method for the manufacture of this assemble according to claim 1. The welding method can also comprise characteristics of claims 2 to 10.

Another objective is achieved by providing an assembly according to claim 11. The assembly can also comprise any characteristics of claims 12 to 20.

20 Finally, also another objective is achieved by providing the use of the assembly according to claim 21.

Other characteristics and advantages of the invention will become apparent from the following detailed description of the invention.

To illustrate the invention, various embodiments and trials of non-limiting
25 examples will be described, particularly with reference to the following Figure:

Figure 1 illustrates an embodiment according to the present invention.

Figures 2 to 5 illustrate Examples of spot welding cycle according to the present invention.

30 Other characteristics and advantages of the invention will become apparent from the following detailed description of the invention.

The designation hardened steel part means a hot-formed or hot-stamped steel sheet having a tensile strength up to 2500 MPa and more preferably up to 2000MPa. For example, the tensile strength is above or equal to 500 MPa, advantageously above or equal to 1200 MPa, preferably above or equal 1500 MPa.

The invention relates to a welding method for the manufacture of an assembly comprising the following steps:

A. The provision of at least two metallic substrates wherein a first metallic substrate is a hardened steel part coated with:

- 5 ▪ an alloyed coating comprising zinc, silicon, optionally magnesium, the balance being aluminum, directly topped by
- A native oxide layer comprising ZnO and optionally MgO,

10 B. The application of a spot welding cycle with a spot welding machine, comprising welding electrodes and a spot welding power source applying an inverter direct current, through the at least two metallic substrates of step A), said spot welding cycle comprising the following sub-steps:

- 15 i. one pulsation having a pulsation current (C_p) applied through said at least two metallic substrates joined together using welding electrodes connected to the spot welding power source and directly after,
- ii. a welding step having a welding current (C_w) through the at least two metallic substrates and

20 wherein the welding force during the spot welding cycle is between 50 and 350 daN, the current C_p is different from the current C_w and the pulsation duration is shorter than the welding duration.

Without willing to be bound by any theory, it seems that the welding method according to the present invention performed on two metallic substrates comprising at least a hardened steel part coated with the specific coating comprising zinc, silicon, optionally magnesium, the balance being aluminum allows a welding range equal or above 1kA and a decrease of coating splashing on the assembly surface. Indeed, it seems that ZnO and optionally MgO are naturally present on the surface of the hardened steel part due to the oxidation of the hardened steel with air. It is believed that the pulsation breaks at least a part of the ZnO and optionally MgO oxide layer and/or alloyed coating present on the coated hardened steel part opening a path to the welding current. Additionally, it seems that the method according to the present invention comprising one pulsation is easy to implement in industrial scale. Finally, it seems that when the welding force is between 50 and 350daN, the welding is improved

since the current is more localized at the electrode center leading to a better expulsion of the alloyed coating and/or oxide layer. However, when the welding force is outside the scope of the present invention, i.e. above 350daN, there is a risk that the nugget is not formed at the interface between the at least two metallic substrates since the current spreads on a larger surface of the coated hardened parts.

As illustrated in Figure 1, a spot welding machine (not illustrated), comprising welding electrodes 1, 1' and a spot welding source 2, is used. In this Example, the electrodes permit to join two hardened steel parts 3, 3' coated with the coating according to the invention 4, 4', 4". During the welding, a nugget 5 is formed between the two hardened steel parts through diffusion. The nugget is an alloy of the residual coatings and the steel parts. Thanks to the spot welding cycle according to the present invention, it is believed that at least a part of the coating is removed in the nugget. Moreover, on the top of the spot welded joint 6, 6', it is believed that at least a part of the native oxide layer and/or alloyed coating is not present. Indeed, it seems that the at least one pulsation breaks the native oxide layer and starts the welding between the coated two hardened steel parts by melting and removing the coatings on top of the spot welded joint and in the nugget. Thus, the current can flow through the two hardened steel parts allowing an improvement of the welding. Finally, it is believed that no cooling is needed between the at least one pulsation and the welding step. Indeed, if a cooling is performed between these steps, there is a risk to stop the formation of the nugget between the two hardened steel parts because the steel parts start to solidify. On the contrary when no cooling is performed, it seems that the steel parts stay in liquid form and can easily be joined together.

Preferably, in step B.i), the pulsation current (C_p) is between 0.1 and 30 kA, preferably between 0.1 and 20kA, more preferably between 8.0 and 20kA and advantageously between 8.0 and 15kA.

Advantageously, in step B.i), the pulsation duration is from 5 to 60ms, preferably from 4 to 30ms.

Preferably, in step B.ii), the welding current (C_w) is between 0.1 and 30 kA, preferably between 0.1 and 20kA, more preferably between 0.1 and 10 and advantageously between 1 and 7.5kA.

Advantageously, in step B.ii), the welding duration is from 150 to 500ms and more preferably from 250 to 400ms.

In a preferred embodiment, the current C_p is below the current C_w .

In another preferred embodiment, the current C_p is above the current C_w . Indeed, without willing to be bound by any theory, the inventors have found that when C_p is above C_w , the welding range is further improved.

5 Preferably, the welding force during the spot welding cycle is between 100 daN and 250 daN, more preferably between 150 and 250 daN.

Preferably, the welding frequency is between 500 and 5000Hz, more preferably 500 and 3000Hz and for example between 800 and 1200Hz.

10 Preferably, the welding step B.ii) comprises a plurality of pulses, the at least one pulsation B.i being directly followed by the first pulse of the welding step. In this case, there is no cooling between the pulsation and the first pulse. The first pulse is followed by one or more pulse(s), a break duration being present between each subsequent pulse. Preferably, the break duration is from 20 to 80ms and preferably from 30 to 60ms.

15 The spot welding cycle according to the present invention can have different shape. Figure 2 illustrates one preferred embodiment wherein the spot welding cycle 21 has a rectangular shape comprising a rectangular pulsation peak 22 and a rectangular welding peak 23. Figure 3 illustrates another preferred embodiment wherein the spot welding cycle 31 has a parabolic shape comprising a parabolic pulsation peak 32 and a parabolic welding peak 33. Figure 4 illustrates another preferred embodiment wherein the spot welding cycle 41 has a triangular shape comprising a triangular pulsation peak 42 and a triangular welding peak 43. According to other embodiments, the spot welding cycle has a parabolic and a rectangular shape comprising a parabolic pulsation peak and a rectangular welding peak or, a triangular and a rectangular shape comprising a triangular pulsation peak and a rectangular welding peak.
20
25

Figure 5 illustrates one preferred embodiment wherein the spot welding cycle comprises one pulsation B.i being directly followed by a first pulse of the welding step. In this Example, the spot welding cycle 51 has a rectangular shape comprising a rectangular pulsation peak 52 and three rectangular welding peaks 53, 53', 53".
30

The invention relates also to an assembly of at least two metallic substrates spot welded together through at least one spot welded joint obtainable with the method according to the present invention, said assembly comprising:

- a first metallic substrate being a hardened steel part coated with:

- an alloyed coating comprising zinc, silicon, optionally magnesium, the balance being aluminum, directly topped by
 - A native oxide layer comprising ZnO and optionally MgO,
- 5 - said spot welded joint comprising a nugget, and said spot welded joint being such that on its top, at least a part of the native oxide layer and/or alloyed coating is not present.

Without willing to be bound by any theory, it seems that when the assembly comprises the above specific coating on the hardened part welded using the welding method according to the present invention, the welding range is equal or above to 1kA. 10 Indeed, it seems that although the thickness of the native oxide layer is higher than the coatings of the prior art, the welding method according to the present invention breaks the native oxide layer and remove at least a part of the native oxide layer and/or alloyed coating allowing a good weldability of the assembly.

Preferably, the alloyed coating of the hardened steel part comprises from 0.1 to 15 40.0% by weight of zinc, more preferably between 0.1 and 20.0% by weight of zinc and advantageously between 5.0 and 14% by weight of zinc and for example between 7.0 and 12.0% by weight.

Preferably, the alloyed coating of the hardened steel part comprises from 0.1 to 20.0% by weight of silicon, more preferably from 0.1 to 12.0% by weight of silicon and 20 advantageously from 0.1 to 6.0% by weight of silicon and for example between 2.0 and 6.0% by weight of silicon.

Preferably, the alloyed coating of the hardened steel part comprises from 0.1 to 20.0% by weight of magnesium, from 0.1 to 10.0%, preferably from 0.1 to 4.0% by weight of magnesium.

25 Optionally, the coating comprises additional elements chosen from Sr, Sb, Pb, Ti, Ca, Mn, Sn, La, Ce, Cr, Zr or Bi, the content by weight of each additional element being inferior to 0.3% by weight and optionally residuals elements from feeding ingots or from the passage of the steel substrate in the molten bath including iron. For example, the amount of iron is up to 5% by weight.

30 In a preferred embodiment, the second metallic substrate is a steel substrate or an aluminum substrate. Preferably, the second steel substrate is a hardened steel part according to the present invention.

In another preferred embodiment, the assembly comprises a third metallic substrate sheet being a steel substrate or an aluminum substrate. In this case, two or several spot welded joints are present.

Finally, the invention relates to the use of the assembly according to the present invention for the manufacture of automotive vehicle.

The invention will now be explained in trials carried out for information only. They are not limiting.

Examples

Example 1: Homogeneous welding test

Trials 1 to 18 being Usibor® 1500 steel sheets were hot-dip coated with a coating comprising 3% by weight of silicon, 2% by weight magnesium, 12% by weight of zinc, the balance being aluminum. Trial 19 being Usibor® 1500 steel sheets was hot-dip coated with a coating comprising 3% by weight of silicon, 2% by weight magnesium, 10% by weight of zinc, the balance being aluminum. The steel sheets were then press hardened at an austenitization temperature between 880 and 950°C for 3-7 minutes.

Then, for each Trial, two identical press hardened part were welded together.

The welding range was determined according to the norm SEP1220-2. Welding test started from 3 kA and increased by 0.2 kA every two spot welds. When two consecutive splashings occurred at the same current level, the splash limit was found. When splash limit was reached, welding current decreased with the step of 0.1 kA to have three consecutive welded samples at the same current level without expulsion. This current level is defined as the upper welding limit of the current range: I_{max}.

After that, the lower limit I_{min} was found. I_{min} search was done by using the criteria of $4\sqrt{t}$, where t is the sheet thickness. This criterion defines the minimum acceptable diameter value that guaranteed the weld quality and strength. For confirmation five consecutive welded samples were obtained with superior welding diameter than minimal welding diameter.

For Trials 1 to 12 and 17 to 19, the welding cycle comprises, optionally one pulsation having a pulsation current C_p, and one welding step having a welding current C_w defined by I_{min} and I_{max} according the norm SEP1220-2. For Trials 13 to 16, the welding cycle comprises one pulsation having a pulsation current C_p and three or four

welding steps having a welding current C_w defined by I_{min} and I_{max} according the norm SEP1220-2, a temporary stop being performed between each welding step.

The frequency was of 1000Hz. The obtained I_{min} , I_{max} and the welding current range are in the following Table 1.

Trials	Zinc percentage in the coating (wt.%)	Austenitization treatment		Welding force (daN)	Pulsation			Current (kA)	Number of welding step(s)	Welding step			Welding current range (kA)
		Temperature (°C)	Time (min)		Number	Duration (ms)	Stop (ms)			Welding current Imin (kA)	Welding current Imax (kA)		
1*	12	880	5	200	1	20	10	1	-	4.45	5.86	1.41	
2	12	880	5	450	1	20	10	1	340	4.45	5.08	0.63	
3*	12	880	8	200	1	20	10	1	340	4.45	5.46	1.01	
4	12	880	8	450	1	20	10	1	340	4.45	4.85	0.4	
5	12	900	5	200	0	-	-	1	-	-	-	0	
6	12	900	5	450	0	-	-	1	-	-	-	0	
7*	12	900	5	200	1	20	10	1	340	4.25	5.46	1.21	
8*	12	900	5	300	1	20	10	1	340	4.4	5.4	1	
9	12	900	5	450	1	20	10	1	340	4.25	5.06	0.81	
10	12	900	5	600	1	20	10	1	340	4.6	5	0.4	
11	12	900	5	800	1	20	10	1	-	-	-	0	
12	12	900	5	1000	1	20	10	1	-	-	-	0	
13	12	900	5	450	1	80	10	3	160	5.6	6.1	yes	
14	12	900	5	450	1	120	10	3	160	4.9	5.4	yes	
15	12	900	5	450	1	160	10	3	160	4.5	4.6	yes	
16	12	900	5	450	1	160	10	4	160	-	-	0	
17*	12	900	7	200	1	20	10	1	340	4.4	5.41	1.01	
18	12	900	7	450	1	20	10	1	340	4.62	5.23	0.3	
19*	10	900	5	200	1	20	10	1	340	4	5.2	1.2	

*: according to the present invention

Trials 5, 6, 11, 12 and 16 were not weldable, i.e. the criterions of I_{min} and I_{max} defined in norm SEP1220-2 were not achieved. Trials according to the present invention have a welding range equal or above 1kA.

Example 2: Heterogeneous welding test

Usibor® 1500 steel sheets were hot-dip coated with a coating comprising 3% by weight of silicon, 2% by weight magnesium, 12% by weight of zinc, the balance being aluminum. The steel sheets were then press hardened at an austenitization temperature between 900°C for 5 minutes. They were welded with DP600 steel grade (C: 0.14wt.%, Mn: 2.1wt% and Si: 0.4wt.%) coated with a zinc coating. The welding range was determined as in Example 1. The frequency was of 1000Hz. The obtained I_{min} , I_{max} and the welding current range are in the following Table 2.

Trials	Welding force (daN)	Pulsation				Welding step			
		Number	Duration (ms)	Stop (ms)	Current (kA)	Welding duration (ms)	Welding current		Welding current range (kA)
							I_{min} (kA)	I_{max} (kA)	
20*	200	1	20	-	10	340	4.8	6.6	1.8
21*	300	1	20	-	10	340	5.2	6.4	1.2
22	800	1	20	-	10	-	-	-	0

*: according to the present invention

Trial 22 was not weldable. Trials according to the present invention have a welding range equal or above 1kA.

Example 3: electrode life test

Electrode life is defined as the last weld number of a test strip before reaching more than two welds out of eight below a minimum weld diameter defined. The minimum weld diameter was of 4.7mm.

Two coated hardened steel parts prepared as Trial 7 were welded together with the welding method according to the present invention comprising one pulsation and the welding step. The pulsation current was of 10kA during 10ms. The welding current was I_{max} determined for Trial 7 in Example 1. A plurality of spot welds was performed with the electrodes on the two coated hardened parts and the weld diameter was measured for each spot weld. Results are in the following Table 3.

Trial	Number of spot welds	Weld diameter (mm)
7*	10	5.2
	100	5.2
	200	5.2
	300	5.2
	400	5.2
	500	5.3
	600	5.4

*: according to the present invention

The weld diameter was always above the minimum weld diameter with Trial 7 according to the present invention.

Claims

1. A welding method for the manufacture of an assembly comprising the following steps:
 - A. The provision of at least two metallic substrates (3, 3') wherein a first metallic substrate (3) is a hardened steel part coated with:
 - an alloyed coating (4) comprising zinc, silicon, optionally magnesium, the balance being aluminum, directly topped by
 - A native oxide layer comprising ZnO and optionally MgO,
 - B. The application of a spot welding cycle with a spot-welding machine, comprising welding electrodes (1, 1') and a spot welding power source (2) applying an inverter direct current, through the at least two metallic substrates of step A), said spot welding cycle (21, 31, 41, 51) comprising the following sub-steps:
 - i. one pulsation (22, 32, 42, 52) having a pulsation current (Cp) applied through said at least two metallic substrates joined together using welding electrodes connected to the spot welding power source and directly after,
 - ii. a welding step (23, 33, 43, 53) having a welding current (Cw) through the at least two metallic substrates andwherein the welding force during the spot welding cycle is between 50 and 350 daN, the current Cp is different from the current Cw and the pulsation duration is shorter than the welding duration.
2. A welding method according to claim 1, wherein in step B.i), the pulsation current (Cp) is between 0.1 and 30.0kA.
3. A welding method according to claim 1 or 2, wherein in step B.i), the pulsation duration is from 5 to 60ms.
4. A welding method according to anyone of claims 1 to 3, wherein in step B.ii), the welding current (Cw) is between 0.1 and 30kA.

5. A welding method according to anyone of claims 1 to 4, wherein in step B.ii), the welding duration is from 150 to 500ms.
6. A welding method according to anyone of claims 1 to 5, wherein the welding force during the spot welding cycle is from 100 daN to 250 daN.
7. A welding method according to claim 6, wherein C_p is below or above C_w .
8. A welding method according to anyone of claims 1 to 7, wherein the welding frequency is from 500 to 5000Hz.
9. A welding method according to claim 8, wherein the welding step B.ii) comprises a plurality of pulses, the at least one pulsation B.i being directly followed by the first pulse of the welding step.
10. A welding method according to anyone of claims 1 to 9, wherein the spot welding cycle shape (21, 31, 41, 51) is selected among:
 - a rectangular form comprising a rectangular pulsation peak (22) and a rectangular welding peak (23),
 - a parabolic form comprising a parabolic pulsation peak (32) and a parabolic welding peak (33),
 - a triangular form comprising a triangular pulsation peak (42) and a triangular welding peak (43),
 - a parabolic and a rectangular shape comprising a parabolic pulsation peak and a rectangular welding peak and
 - a triangular and a rectangular shape comprising a triangular pulsation peak and a rectangular welding peak.
11. An assembly of at least two metallic substrates (3, 3') spot welded together through at least one spot welded joint obtainable according to claims 1 to 10, said assembly comprising:
 - a first metallic substrate (3) being a hardened steel part coated with:
 - an alloyed coating (4) comprising zinc, silicon, optionally magnesium, the balance being aluminum, directly topped by

- A native oxide layer comprising ZnO and optionally MgO,
 - said spot welded joint comprising a nugget (5); and said spot welded joint being such that on its top (6), at least a part of the native oxide layer and/or alloyed coating is not present.
12. An assembly according to claim 11, wherein the alloyed coating of the hardened steel part comprises from 0.1 to 40.0% by weight of zinc.
13. An assembly according to claim 12, wherein the alloyed coating of the hardened steel part comprises from 0.1 to 20.0% by weight of zinc.
14. An assembly according to anyone of claims 11 to 13, wherein the alloyed coating of the hardened steel part comprises from 0.1 to 20.0% by weight of silicon.
15. An assembly according to claim 14, wherein the alloyed coating of the hardened steel part comprises from 0.1 to 15.0% by weight of silicon.
16. An assembly according to anyone of claims 11 to 15, wherein the alloyed coating of the hardened steel part comprises from 0.1 to 20.0% by weight of magnesium.
17. An assembly according to claim 16, wherein the alloyed coating of the hardened steel part comprises from 0.1 to 10.0% by weight of magnesium.
18. An assembly according to anyone of claims 11 to 17, wherein the second metallic substrate is a steel substrate or an aluminum substrate.
19. An assembly according to claim 18, wherein the second steel substrate is a hardened steel part according to anyone of claims 11 to 17.
20. An assembly according to anyone of claims 11 to 19, comprising a third metallic substrate sheet being a steel substrate or an aluminum substrate.

21. Use of an assembly according to anyone of claims 11 to 20, or obtainable according to the method of anyone of claims 1 to 10, for the manufacture of automotive vehicle.

Figure 1

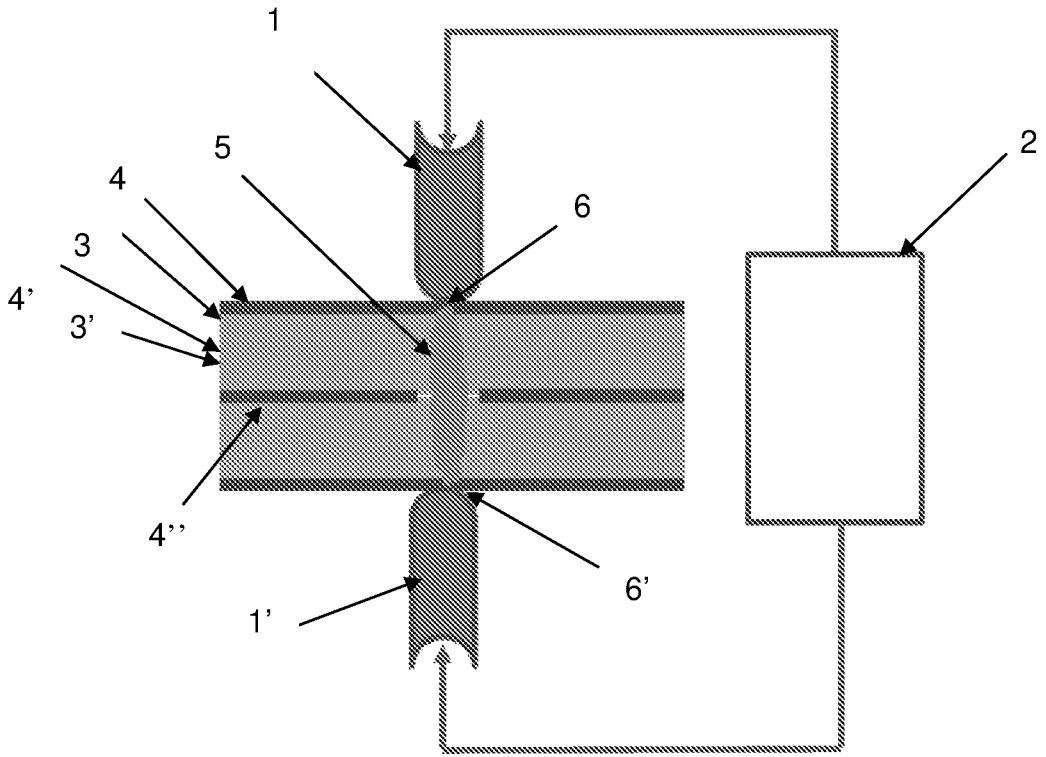

Current (kA)

Figure 2

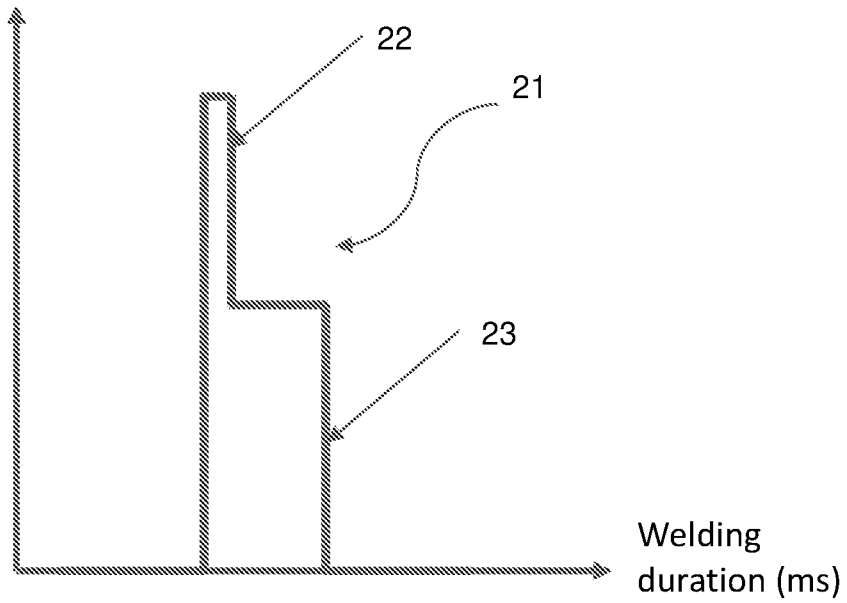

Figure 3

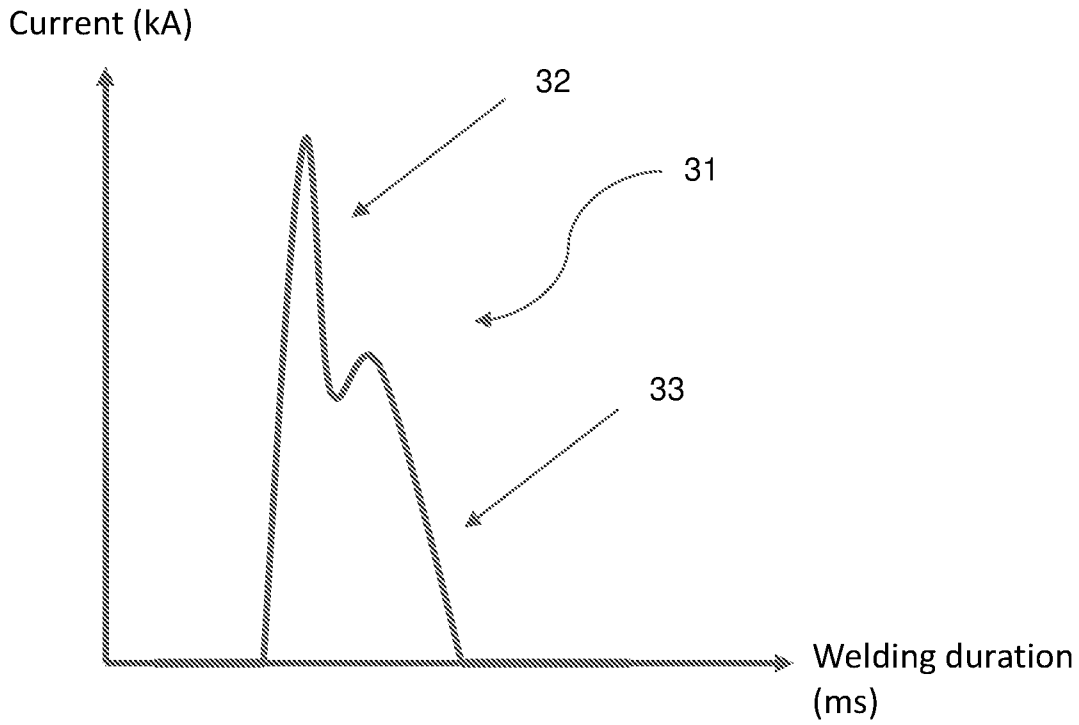

Figure 4

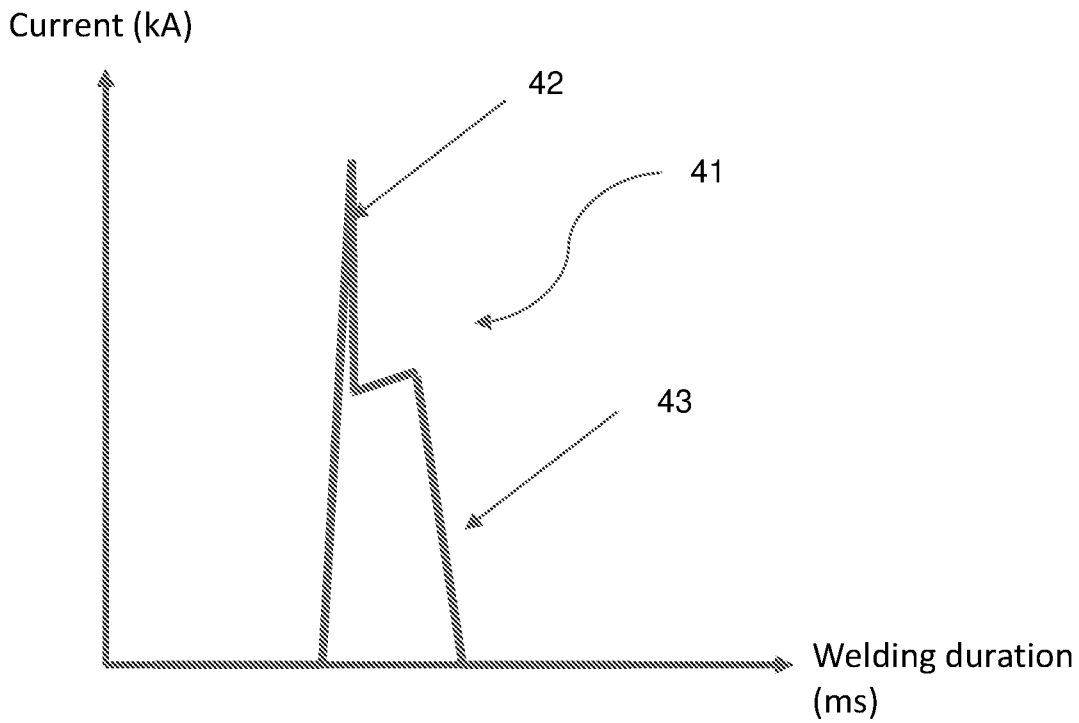

Figure 1

