

Dec. 13, 1932.

E. M. WHITE

1,890,708

SUPERCHARGER

Filed May 31, 1930

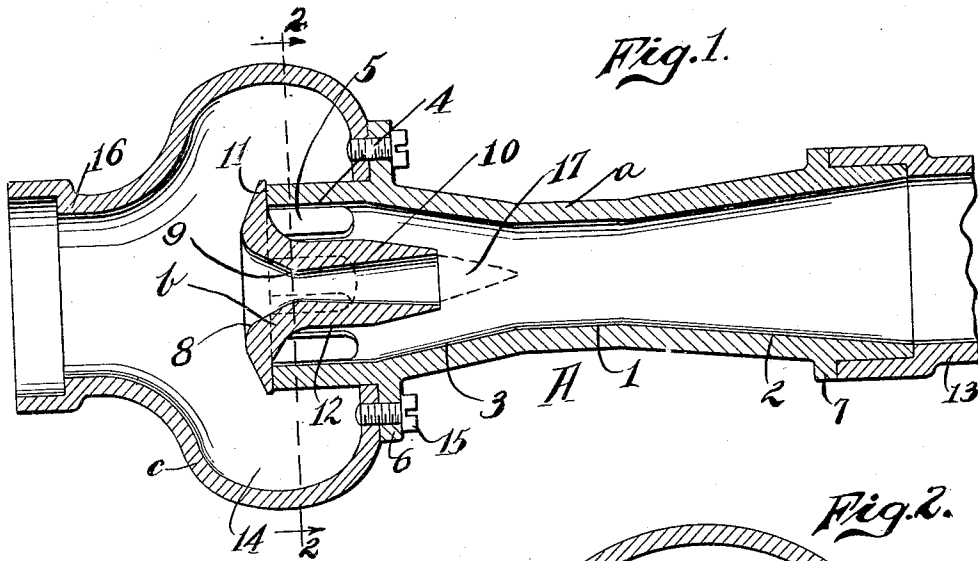

Fig. 1.

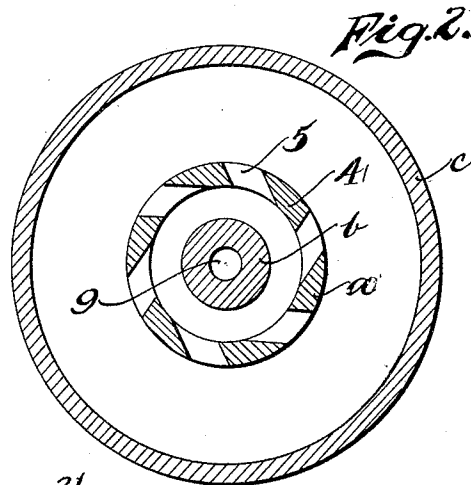

Fig. 2.

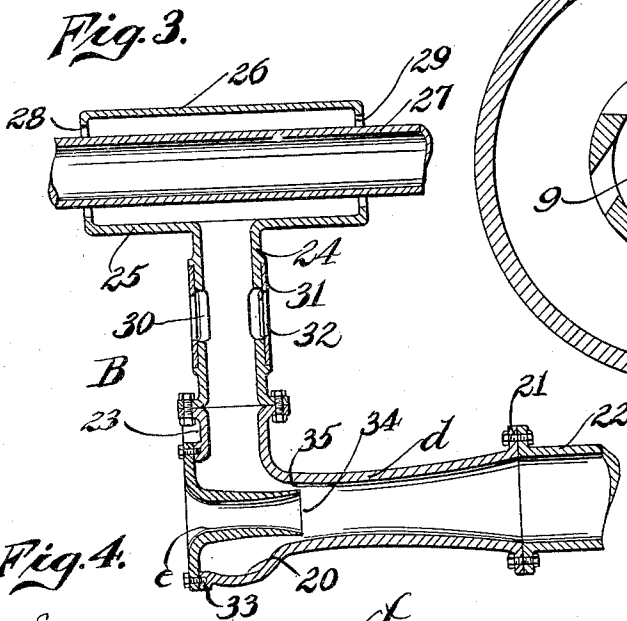

Fig. 3.

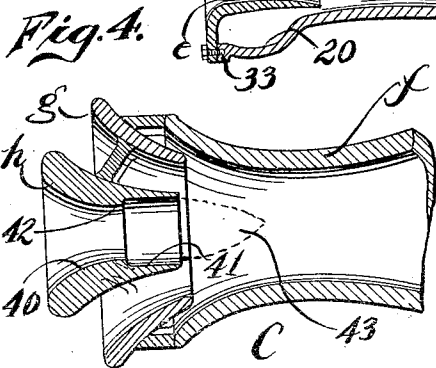

Fig. 4.

Inventor,
Ernest M. White;

By *Calvin Brown,*
Attorney

UNITED STATES PATENT OFFICE

ERNEST M. WHITE, OF LOS ANGELES, CALIFORNIA

SUPERCHARGER

Application filed May 31, 1930. Serial No. 458,806.

This invention relates to superchargers, and has for an object the provision of a supercharger which is so constructed as to give increased efficiency to internal combustion engines operating under different working conditions. The function and purpose of superchargers is now well understood in the art, and the present form of the invention presents a supercharger which is simple of construction, easily assembled, inexpensive of manufacture and one which may be readily installed for use with existing types of internal combustion engines without extensive modification or reconstruction of parts. In fact, any standard form of engine utilizing the usual carburetor may embody the improved supercharger. The invention is so constructed as to give maximum power to the engine.

In practicing an embodiment of the invention, I have provided a supercharger adapted to operate in such a manner as to allow the air drawn therethrough to be heated, the arrangement being such that no complicated construction results or is necessary.

Other objects will appear as the description proceeds, and with the objects above enumerated, the said invention consists in the novel and useful provision, formation, construction, association, and relative arrangement of parts, members and features, all as shown in certain embodiments in the accompanying drawing, described generally, and more particularly pointed out in the claims.

In the drawing:

Figure 1 is a longitudinal sectional view of one form of supercharger,

Figure 2 is a sectional view on the line 2—2 of Figure 1,

Figure 3 is a cross sectional view of a modified form of supercharger utilizing the hot air principle, and

Figure 4 is a cross sectional view of a modified form of supercharger.

Referring with particularity to the drawing, the supercharger shown in Figures 1 and 2 is designated as an entirety by A, that in Figure 3 by B, and in Figure 4 by C. The form of the invention designated as A includes a draft tube *a*, the approximate cen-

tral portion 1 of which has a bore of uniform diameter with portions extending from such zone 1 flaring outwardly, as shown at 2 and 3. This is of the ordinary Venturi tube construction with the possible exception that a part of uniform diameter 4 is associated with the flared portion 3. This portion 4 is likewise provided with a plurality of longitudinally extending spaced slots 5. An annular flange 6 is formed between the parts 3 and 4, and an annular flange 7 is formed on the part 2. A nozzle *b* is adapted to be received within the mouth of the part 4 and to extend a certain distance within the part 3. This nozzle has a bore resembling the inner bore of a Pitot tube in that it has a flared mouth 8 leading to a restricted zone 9 with the bore again flaring or tapering from said restricted zone as shown at 10. Furthermore, this nozzle is constructed so as to be secured to ends of the part 4 as shown at 11. The periphery or particularly that portion 12 of the nozzle is spaced from the inner surface of the part 4. A tube 13 may receive an end portion of the draft tube *a* and bear against the flange 7. This tube 13 may lead to the air intake of a carburetor, not shown. The supercharger may include the elements just described or it may utilize in addition a member *c*. This member *c* is formed with a bulbular or curved chamber portion 14, with said member *c* joined with the flange 6 by any suitable means such as shown at 15. This bulbular part of the curved chamber portion communicates with the part 16 of restricted diameter. This member may in turn be associated with an air cleaner, not shown, of any construction.

The operation, uses and advantages of the device A are as follows:

During intake strokes of an internal combustion engine associated with a carburetor, air is drawn through the carburetor. If now the air intake opening of the carburetor is associated with the draft tube *a*, air will be drawn through said tube. In particular, air will be passed both through the nozzle *b* and the openings or slots 5. There will be a zone of low pressure created forward of the nozzle and within the draft tube, theoreti-

cally the zone 17. The tendency will, therefore, be to draw more air through the slots 5 than would otherwise be passed there-through. Thus, a greater weight of air is delivered to the carburetor. Reference to Figure 2 reveals the fact that the slots 5 are cut at an angle. The result will be that air drawn through said slots is given a whirl and a turbulence is created within the draft tube and this turbulence functions similarly to turning a cork to force the same into the neck of a bottle. This function is similar to a whirlwind, in that a region of low pressure is created at the center of the whirl and this turbulence or whirling action of the air plus the zone of low pressure 17 functions to increase the weight of air received within the draft tube in the manner just described.

The form of the invention designated as B includes a draft tube *b*, one end of which is formed with an enlarged chamber portion 20 and the other end being provided with an annular flange 21 whereby the tube may be secured to a tube 22 communicating in the present instance with the air intake opening of a carburetor. Furthermore, the said draft tube above the portion 20 is provided with an annular flange 23. Adapted to be secured to the flange 23 is a tube 24 communicating with a stove 25. This stove constitutes a casing or shell 26 surrounding a hot pipe 27 which may be the exhaust manifold of an internal combustion engine. This casing is spaced slightly from the pipe 27, as shown at 28 and 29. The pipe 24 is provided with longitudinally extending spaced slots 30 and surrounding said pipe is an annulus 31 provided with one or more slots 38 adapted to register at portions with the slots 30 and to regulate the amount of air passed through said slots 30 into the tube 24. A nozzle *e* is secured to the mouth of the enlarged chamber portion 20, as shown at 33. This nozzle has a bore corresponding to the usual Pitot tube and the Pitot tube opens within the draft tube *d*, particularly beyond the part 20.

In operation, assuming that the device is secured to or associated with the air intake of a carburetor, air is drawn through the draft tube *d*. Warm air would be drawn through the tube 24, the air being heated by the hot pipe 27, into the draft tube, and colder air would be drawn through the nozzle *e*. Likewise air might be drawn through the slots 30. A region of low pressure would be created at the exit end of the said nozzle or particularly the zone 34 which would tend to draw a greater weight of air through the draft tube *d* than would otherwise be drawn therethrough. A jet action would occur at the zone 35. This form of supercharger will work with maximum efficiency under varying conditions and supply heated air to the carburetor. Turbulence of the air is likewise created by the air being drawn through

the tube 24 and into the chamber bounded by the curved portion 20. In this respect, the device functions somewhat similarly to the supercharger A.

The form of the invention C includes a draft tube *f* adapted to operate in conjunction with infusers *g* and *h*. The infuser *h* functions as a nozzle. The infuser *g* is bell-like in form and is fitted so as to be in part received within the mouth or infuser end of the draft tube. The nozzle or infuser *h* is likewise provided with a tapered or flared opening 40 and with a portion of uniform diameter 41. The portion 41 has a greater diameter than a portion 42 which leads to the mouth of the infuser. Each of the devices *f*, *g*, and *h* are slightly spaced apart, as shown in the figure. This device is adapted to operate in conjunction with the air intake of a carburetor and air would be drawn as between the mouth or infuser end of the draft tube and the infuser *g* and likewise between the infuser *g* and *h* and through the opening of said infuser. A zone of low pressure would be created by the infuser *h* whereas air passed as between the draft tube *f* and *g* and the infuser *g* and *h* would have a jet action, tendency being to increase the weight of air that would ordinarily be drawn through the draft tube. The part of uniform diameter 41 would tend to provide a zone of reduced pressure upon passage of air through the flared end of said infuser. This low pressure area which would be approximately in the zone 43 would tend to cause more air to be drawn through the space included between the infuser ends. It is important to note that all of the superchargers just described are adapted to be operated by some member or device which is drawing the air through the said device as distinguished from that type of apparatus wherein some injector or blower or the like, is placed forward of the drafting tubes or infusers. This device is adapted to be operated solely by an associated object.

All various adaptations or uses of the invention are contemplated by this invention whether the supercharger be used for the purpose of drawing air or other fluid there-through or whether said invention is associated with an internal combustion engine or exhauster, pump or the like.

It is obvious that various changes and modifications and variations may be made in practicing the invention in departure from the particular showing of the drawing without departing from the true spirit thereof.

I claim:

1. In a supercharger, a Venturi-type draft tube having entrance and exit portions, a nozzle fitted within the entrance portion of the draft tube and having a Venturi-type bore; and said nozzle being provided with a flange adapted to close direct entrance into

the draft tube, said draft tube being formed with an angularly cut slot adjacent the entrance of said tube, said draft tube being adapted for association with an exhauster at the exit end thereof, and whereby when said exhauster is in operation, fluid is drawn through said nozzle and said slot, the said nozzle creating a low pressure area and the said slot inducing a whirling motion to the fluid whereby a greater weight of air is passed through the draft tube.

2. In a supercharger, a Venturi-type draft tube having a plurality of slots formed therein adjacent the entrance end thereof, a nozzle having a Venturi-type bore, said nozzle positioned within and having a portion closing the direct entrance end of said draft tube, and a chambered member encircling and having a portion joined to said draft tube at a point beyond the slots therein, said draft tube adapted to be associated with an exhauster at the exit end thereof, said chambered member adapted to be connected with an air cleaner, whereby upon operation of the exhauster a low pressure area within the draft tube will be created by said nozzle and a whirling motion imparted to fluid by the slots in the draft tube.

3. In a supercharger, a Venturi-type draft tube having entrance and exit portions and a plurality of angularly disposed slots formed therein adjacent the entrance end thereof, a nozzle having a Venturi type bore and lateral flange formed thereon, said nozzle being axially mounted within said draft tube and having a flange thereon closing the direct entrance end thereof, and a chambered member enclosing the entrance portion of said draft tube, said draft tube adapted to be interconnected with a suction creating device at the exit end thereof and said chambered member to an air cleaner, said nozzle creating a low pressure area and the slots a whirling motion to fluid whereby a greater weight of air will be passed through the draft tube during operation of the suction device.

4. In a supercharger, a draft tube having entrance and exit portions, a nozzle having a Venturi-type bore, said nozzle mounted in the entrance portion of said draft tube and having a lateral portion closing the direct entrance end thereof, and a chambered member connected to and communicating with the bore of said draft tube.

In testimony whereof, I have signed my name to this specification at Los Angeles, California, this 9th day of October, 1928.

ERNEST M. WHITE.