

(12) INTERNATIONAL APPLICATION PUBLISHED UNDER THE PATENT COOPERATION TREATY (PCT)

(19) World Intellectual Property Organization  
International Bureau



(43) International Publication Date  
21 November 2002 (21.11.2002)

PCT

(10) International Publication Number  
WO 02/092917 A1

- (51) International Patent Classification<sup>7</sup>: E02B 3/06
- (21) International Application Number: PCT/US02/14423
- (22) International Filing Date: 9 May 2002 (09.05.2002)
- (25) Filing Language: English
- (26) Publication Language: English
- (30) Priority Data:  
09/852,035 10 May 2001 (10.05.2001) US
- (71) Applicant: BEACH RECLAMATION, INC. [US/US];  
3660 Hartsfield Road, Tallahassee, FL 32303 (US).
- (72) Inventors: BENEDICT, Charles, E.; 3207 Remington Run, Tallahassee, FL 32312 (US). DOBBS, James, R.; 3122 Cabot Road, Tallahassee, FL 32312 (US). PONDER, Perry, L.; 1513 Colonial Drive, Tallahassee, FL 32303 (US).
- (74) Agent: DOWELL, Ralph, A.; Dowell & Dowell, P.C., 1215 Jefferson Davis Highway, Suite 309, Arlington, VA 22202 (US).
- (81) Designated States (national): AE, AG, AL, AM, AT, AU, AZ, BA, BB, BG, BR, BY, BZ, CA, CH, CN, CO, CR, CU, CZ, DE, DK, DM, DZ, EC, EE, ES, FI, GB, GD, GE, GH, GM, HR, HU, ID, IL, IN, IS, JP, KE, KG, KP, KR, KZ, LC, LK, LR, LS, LT, LU, LV, MA, MD, MG, MK, MN, MW, MX, MZ, NO, NZ, OM, PH, PL, PT, RO, RU, SD, SE, SG, SI, SK, SL, TJ, TM, TN, TR, TT, TZ, UA, UG, UZ, VN, YU, ZA, ZM, ZW.
- (84) Designated States (regional): ARIPO patent (GH, GM, KE, LS, MW, MZ, SD, SL, SZ, TZ, UG, ZM, ZW), Eurasian patent (AM, AZ, BY, KG, KZ, MD, RU, TJ, TM), European patent (AT, BE, CH, CY, DE, DK, ES, FI, FR, GB, GR, IE, IT, LU, MC, NL, PT, SE, TR), OAPI patent (BF, BJ, CF, CG, CI, CM, GA, GN, GQ, GW, ML, MR, NE, SN, TD, TG).
- Published:**  
— with international search report  
— before the expiration of the time limit for amending the claims and to be republished in the event of receipt of amendments
- For two-letter codes and other abbreviations, refer to the "Guidance Notes on Codes and Abbreviations" appearing at the beginning of each regular issue of the PCT Gazette.*

(54) Title: PERMANENT AND SEMI-PERMANENT GROUYNE STRUCTURES AND METHOD FOR SHORELINE AND LAND MASS RECLAMATION

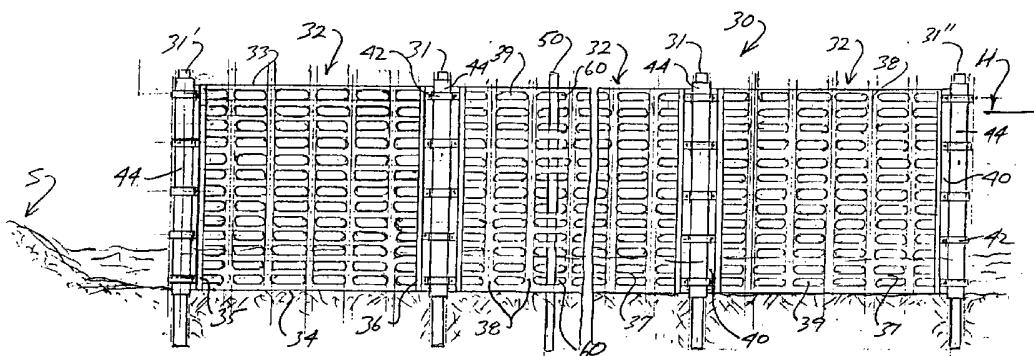

(57) Abstract: Porous groynes (30) for land reclamation which includes a plurality of spaced stanchions (31) and at least one screen grid (32) means having a plurality of openings (39) therein through which fluid and fluid conveyed solids may pass and wherein the screen grid means is formed of a self supporting high density polyethylene, polypropylene, polymers, co-polymers, polymer mixtures or laminates.

WO 02/092917 A1



property. Such structures are costly and are only practical when population densities make it economically reasonable to construct them. Further, such structures have an adverse effect on the natural appearance of the shoreline and, in  
5 many areas, cannot be practically constructed.

Other methods of shoreline reclamation include creating jetties or artificial barriers or reefs which extend from the shoreline. These structures are permanent installations and are generally utilized to prevent sand along coastal  
10 areas from washing out to sea by wave action. Like seawalls, however, such structures are costly to construct and maintain and, in some areas, are not appropriate for use due to the shoreline configuration, prevailing currents or tidal activity and the like. Also, such structures create a  
15 safety hazard in areas where recreational activity is anticipated.

A further method for reclaiming shoreline areas and preventing erosion is the placement of off-shore, underwater barriers. Often, large porous structures are placed along a  
20 sea floor or riverbed at some distance from the existing shoreline. The structures are provided to break wave, current or tidal action thereby creating a zone of low velocity water flow adjacent a beach or riverbank so that sand, silt and other particulate material will settle out of  
25 the water before being conveyed by fluid currents out from the shoreline. Again, such outer barriers are only appropriately used in some locations and are not appropriate for use in many locations and may be objectionable for use in some areas due to the adverse affect on aquatic life.

Other methods which are widely used to reclaim shorelines or beaches are dredging and sand importation. When major dunes along a shoreline are damaged or washed away during heavy storms, it is often necessary to import  
5 new dirt and sand to re-establish the dunes to provide a natural barrier to tidal activity. Dredgers are commonly utilized to pump sand from a sea floor or riverbed to build up natural barriers. Such methods of shoreline reclamation, however, are temporary measures, at best, and do not provide  
10 a long-term solution to shoreline erosion. Further, such restoration methods are extremely costly and are not practical in many locations.

In view of the foregoing, there is a need to provide a method and apparatus for economically reclaiming damaged  
15 shorelines, and other land mass beach areas which can be practically used without an adverse effect to either land or water environments. In United States Patents 1,969,123 and 4,710,056, methods and structures for beach restoration are disclosed which utilize netting for purposes of trapping  
20 sand, shells and other particulate matter carried by wave action. Nets are extended outwardly from the shoreline and are left in place until a buildup of sand and other particulate matter is established after which the nets, which may be buried several feet or more in the newly  
25 collected material, are withdrawn by winches or other means. The removal of the netting material can adversely affect the restored shoreline by creating trenches or furrows which form natural channels in which water flows away from the shoreline thereby conveying particulate matter back to a  
30 body of water.

In prior US Patents 5,720,573 and 5,944,443, screen or netting structures for groynes are disclosed wherein the screens are periodically raised as material is deposited during reclamation so as to reduce interference with newly  
5 deposited materials. During use, flexible materials such as screening and netting are effective for material build-up, however, under some deployment conditions such as during violent storms and sea surges, such groyne structures can be significantly damaged. Damage to screening or netting  
10 mandates added cost for required repair and replacement in order to maintain an effective groyne system.

Also, many groyne systems, such as described in the aforementioned patents, are specifically designed to be removably deployed. In some areas, such as along coastal or  
15 other shorelines it may be more beneficial to deploy or erect groyne systems which are designed to be semi-permanent or permanent. Such groyne systems must be constructed to withstand the forces encountered including wind, wave and tidal action over extended periods of time.

20

## SUMMARY OF THE INVENTION

The present invention is directed to a method and apparatus for reclaiming shoreline, beach and offshore areas which includes the installation of semi-permanent or permanent groyne structures defined having a plurality of  
25 posts or stanchions which are embedded in a sea floor, or in other areas, so as to be in spaced relationship with respect to one another, such as extending from a shoreline to an offshore area and between which are mounted one or more porous screens. The stanchions may be generally aligned in spaced

relationship with one another or may be staggered in offset relationship. In some preferred embodiments, the stanchions may be placed in sets which include at least two end stanchions to which the screens are secured. As used  
5 herein, the term shoreline refers to both land and off shore bottom areas including beaches and banks situated along lakes, rivers, inlets, bays, seas, oceans and the like, it being the express purpose of the invention to build-up solid material deposits both on and off shore.

10 The screens of the present invention are formed in the preferred embodiments of a molded, laminated or extruded open plastic mesh or open grid material. A preferred material is Tensar Geo-grid<sup>®</sup> which is an integrally formed grid structure manufactured of stress resistant high density  
15 polyethylene or polypropylene or other polymers, co-polymers or polymer mixtures or laminates thereof and sold by Earth Technologies, Inc. of Atlanta, Georgia. Such grids can be formed to provide uniaxial properties or biaxial properties with the mesh openings between cross-members of the grids  
20 varying in size depending upon anticipated use.

The screens are mounted on stanchions or poles which are embedded into the sea floor or into other soil preferably by clamping or otherwise securing end edges of separate screens to sleeves which are slidably disposed  
25 about the spaced stanchions. In this manner, when the screens are originally installed, the lower edges thereof rest on and become temporarily embedded in deposited material forming a new land mass. The screens can be left in place when deployed or they may be elevated with respect  
30 to newly deposited material such that the lower edges rest

on or remain slightly embedded in the newly deposited material. Means for elevating each screen may include hoists, cranes and the like which are positioned adjacent the groyne structures. The hoist may be selectively secured  
5 to either the sleeves or to the screen material in order to provide a lifting force so as to slide the supporting sleeves vertically upwardly relative to the spaced stanchions.

To further facilitate the manner in which the screens  
10 of the present invention may be elevated, in preferred embodiments, each screen is secured at its ends to stanchions on the sleeves not supporting other screens, however, in some embodiments the stanchions or sleeves may support adjacent screens in end-to-end relationship. In  
15 some embodiments, when separate pairs of end stanchions are used to support separate screens in generally end-to-end relationship, adjacent stanchions of the pairs may be connected to one another such as by clamps, rings or other connections such that the forces directed against one of the  
20 joined stanchions are distributed to, and resisted by, the other stanchions.

As a further improvement, in some embodiments, each screen may be subdivided into separate vertical sections each of which may be secured to a plurality of separate  
25 sleeves movably mounted on end supporting stanchions. In this manner, as the screen sections are raised, the uppermost sections can be removed from the groyne structure as is necessary.

Whether or not a single vertical screen or a plurality

of vertical screens are used between spaced stanchions, in preferred embodiments the mesh openings of the screens should be smaller adjacent the lower portion of the groyne structures, although in some embodiments the mesh opening  
5 may be uniformed throughout the groyne structures. Further, the mesh openings may be of varied configuration and may be elongated and non-rectangular, rectangular, square or other configuration and be within the teachings of the present invention. The size of the mesh openings, may vary. The  
10 openings may be created by forming the mesh openings at varied dimensions during manufacture or may be constructively formed by overlapping separate screen grids so as to define openings of different sizes. This can be accomplished by placing two screen grids in face-to-face  
15 relationship with respect to one another such that their openings are not aligned and securing such face-to-face screens to sleeves slidably mounted on common end stanchions.

As a variation of the preferred embodiment, the screen  
20 grids may be formed so as to permit a weaving of either the sleeves or the stanchions between vertically spaced openings in each screen. In this manner, a screen may be directly secured without mechanical fasteners to a stanchion or to a sleeve slidably mounted on a stanchion. This may be  
25 preferred where a screen has a significant horizontal length so as to allow an intermediate portion of the screen to be secured in a relatively inexpensive manner to an intermediate stanchion.

As opposed to directly mounting the screens to the  
30 sleeves or stanchions of the invention, various fasteners



may be utilized to secure portions of the screens directly to the sleeves or stanchions. Such fasteners may be clamps constructed of plastics or metal. Further, the sleeves may be cylindrical sleeves or may be molded sleeves having  
5 flanges which may be secured to the ends of the screens. In some embodiments, the sleeves may be formed as split sleeves having outwardly extending flanges between which an end portion of a screen may be secured, such as by of the use of bolts or other fasteners, fusing, welding or other means.

10 Utilizing the methodology of the present invention, a plurality of spaced groyne structures are positioned so as to extend in spaced relationship with respect to one another such as outwardly from a shoreline. The orientation between the groyne structures and the angular relationship with  
15 respect to other areas or land masses, such as a shoreline, will be dictated by the specifics of a given area including winds, currents, tidal activity and the like. Once the screens have been secured to the stanchions, the screens may be left in place as semi-permanent or permanent structures  
20 or they may be elevated periodically as deposits are formed so as not to become too deeply embedded in the newly deposited material and thus not disturb the newly deposited material.

It is the primary object of the invention to provide a  
25 method and apparatus for economically reclaiming land including along shorelines and off shore areas of oceans, gulfs, inlets, bays, rivers, lakes as well as other areas where currents, tidal and/or wind activity is experienced and wherein the structures exhibit permanent or semi-  
30 permanent characteristics being sufficiently strong and

rigid to withstand stresses imparted thereto by strong storm surges and heavy tidal activity.

It is a further object of the invention to provide groyne structures and a method for installing such  
5 structures wherein the structures may be temporarily installed and removed after land has been reclaimed without disturbing the natural contour of the reclaimed land.

It is also an object of the invention to provide groyne structures to reclaim land which are environmentally  
10 compatible and which will not deteriorate by exposure to normal environmental conditions including ultra-violet light or sea water.

#### BRIEF DESCRIPTION OF THE DRAWINGS

A better understanding of the invention will be had  
15 with respect to the attached drawings wherein:

Fig. 1 is a front elevational view having portions broken away of a groyne constructed in accordance with the invention showing a plurality of separate screen grids being mounted to spaced stanchions by way of sleeves removably  
20 mounted about the stanchions;

Fig. 2 is a top plan view of the groyne system of Fig. 1;

Fig. 3 is an enlarged partial section of one screen grid of Fig. 1 showing the mounting of the screen to sleeves  
25 disposed about the spaced stanchions;

Fig. 4 is a cross-sectional view taken along line 4-4 of Fig. 3;

Fig. 5 is a cross-sectional view taken along line 5-5 of Fig. 3;

5 Fig. 6 is a view of an alternate securing device for securing the screen grids to the sleeves or stanchions of the present invention;

Fig. 7 is a cross-sectional view taken along lines 7-7 of Fig. 6;

10 Fig. 8 is a perspective view of the fasteners shown in Figs. 6 and 7;

Fig. 9 is a partial front plan view showing a first form of grid pattern or mesh configuration for a screen of the invention;

15 Fig. 10 is a partial front plan view showing an alternate embodiment of mesh configuration for screens of the invention;

Fig. 11 is a partial front plan view of yet another embodiment of mesh configuration for use with the invention;

20 Fig. 12 is a partial top plan view showing the reinforcement of the screen grid of Fig. 11;

Fig. 13 shows a biaxial strengthened screen grid for use with the invention;

Fig. 14 is a partial front plan view of another embodiment of the invention showing separate vertical screens sections mounted to end stanchions by way of separately moveable supporting sleeves;

5 Fig. 15 is a cross-sectional view taken from above of a pair of spaced stanchions showing adjacent screens being mounted to separate stanchions by way of sleeves mounted to the spaced stanchions in a manner similar to the structure of Fig. 17;

10 Fig. 16 is a perspective view having portions broken away of one of a pair of elongated clamps which may be used to secure the end edges of each screen to a sleeve or stanchion of the invention;

Fig. 17 is a front elevational view having portions  
15 broken away showing a further modification of the porous groyne system of the invention wherein, in order to create different sized openings in the groyne structure, separate screen grids are placed in face-to-face relationship with the mesh openings therein not in alignment, thus varying the  
20 effective mesh openings, especially along a lower portion of the groyne.

Fig. 18 is a view taken along lines 18-18 of Fig. 17;

Fig. 19 is a cross-sectional view taken along line 19-19 of Fig. 17;

25 Fig. 20 is a partial perspective view of a split sleeve which may be used to secure the end edges of the screens of

the invention to the stanchions;

Fig. 21 is a perspective view with portions broken away of an alternate embodiment of sleeve which may be utilized to secure the screens of the invention to the stanchions;

5 Fig. 22 is a front elevational view of the groyne structure of Figs. 1 and 2 showing a varied deployment of the stanchions and screen sections;

Fig. 23 is a top plan view of the groyne deployment of Fig. 22;

10 Fig. 24 is a top plan illustrational view showing one of the groyne structures deployed as a porous breakwater extending generally parallel to a shoreline so as to dissipate wave energy as waves approach the shoreline; and

15 Fig. 25 is a front plan view of the porous breakwater shown in Fig. 24.

#### DESCRIPTION OF THE PREFERRED EMBODIMENT

With continued reference to the drawing figures, a groyne 30 of the present invention will be shown as being deployed along a shoreline "S" of a gulf, ocean, lake, river  
20 or the like such that the structure extends from the shoreline to off shore with the height of the structure being such that the screens of the structure extend generally above or below the water surfaces, such as above the high tide line "H". The groyne structures are

specifically constructed so that they may be permanent or semi-permanent or, when environmental or other conditions require, the structures may also be readily removed or adjusted so as to not adversely affect movement of aquatic  
5 life.

Each groyne structure 30 includes a plurality of spaced stanchions, posts, or poles 31 which are preferably formed of a non-corrodible material such as galvanized pipe having lower ends which are inserted into a sea floor "F" in any  
10 appropriate manner such as by vibration, jetting, drilling and the like. The stanchions may be spaced at varying distances with respect to one another and extend generally perpendicularly or angularly outwardly from the shore "S" to a point off shore. For purposes of description, the  
15 innermost stanchion is designated as 31' and the outermost stanchion as 31". As shown in Figs. 15, 17, 22 and 23 in preferred embodiments, the stanchions intermediate the innermost and outermost stanchions may be placed adjacent to or in close proximity of one another in sets of at least two  
20 end stanchions for purposes of separately supporting screen grids 32 which extend between the stanchions. In this manner, each screen grid 32 is supported by separate stanchions such that each screen may be independently vertically maneuvered without effecting the positioning of  
25 an adjacent screen grid.

The screens of the invention are formed of a plastic geogrid material or of a geotextile and plastic laminate material in which the length of each screen may vary. In preferred embodiments, the screen sections should be  
30 approximately 10 to 20 feet in length and may vary from 4 to

10 feet in height. In this respect, the stanchions 31 will be spaced generally in equal increments with the exception of adjacent stanchions which support the end portions of adjacent end-to-end screens.

5           Each screen grid 32 includes an upper edge 33 a lower edge 34 and opposite side or end edges 35 and 36. The screens are molded, laminated, pultruded, or slit and pulled or otherwise configured extruded into open mesh structures. The configuration of the openings shown at 39 in Fig. 1 may  
10 vary as will be described in detail. The resulting screen structures generally include a plurality of horizontal components 37 which are integral with a plurality of vertical components 38. A preferred material is Tensar Geo-grid® which is an integrally formed grid structure  
15 manufactured of stress resistance high density polyethylene, polypropylene or other polymers, co-polymers or polymer mixture or laminates thereof and which are sold by Earth Technology, Inc. of Atlanta, Georgia. The material from which the screens are formed should be treated to provide  
20 resistance to ultra-violet deterioration and not deteriorate by prolonged exposure to salt water.

          The screen grids 32 shown in Fig. 1 show openings 39 of generally uniformed size throughout. However, it is envisaged that the openings may not be uniformed throughout  
25 each screen. In some embodiments, the openings along the lower portion of the screens may be formed so as to be smaller in dimension than openings in upper portions of the screens in order to be more effective in creating deposits of finer particulate materials along the base of the screens  
30 when the screens are deployed as shown in Fig. 1. It is

generally preferred that the minimum dimension of the openings not exceed generally one inch and the openings shown in the drawings are somewhat exaggerated in size and are not drawn to scale.

5           One of the features of the screens of the invention is that they exhibit a great deal of strength and yet offer some flexibility along their length so that each section is easily handled to facilitate installation. However, the overall screens are self supporting and are thus  
10 substantially rigid enough to resist forces applied substantially in any direction relative thereto.

          In the embodiment shown in Fig. 1, the end edges 35 and 36 of each screen are clamped between elongated and opposing clamp members 40, see Fig. 16, which are somewhat "V"-  
15 shaped in cross section to facilitate engagement with the tapered edges of the ends 35 and 36 of the screen, as shown in Figs. 4 and 5. The clamp members are urged against the end edges by band clamps 42 which are mounted about sleeves 44 which are of a size to be slidably received about the  
20 stanchions 31. Bolts or other fasteners 45 extend through aligned openings in the band clamps 42 and in the clamp members 40 in order to secure the end edges of the screens to the sleeves 44.

          The sleeves 44 may be formed of substantially any  
25 material which exhibits resistance to deterioration by exposure to salt water and ultra-violet light such as a suitable plastic material. It is preferred that the sleeves are slidable relative to the stanchions so as to permit a selected vertical elevation of the sleeves relative to the



stanchions to permit raising of the screens as may be required. As shown, a number of clamps 42 may be used to secure the ends of each screen 32 to a sleeve 44.

With specific reference to Figs. 17-20, a different  
5 embodiment of sleeve 44a is disclosed in the form of a split sleeve. The split sleeve 44a includes a pair of elongated flanges 46 which are integrally molded with the remaining portion of the sleeve and which have a plurality of spaced openings 47 therein for purposes of receiving the locking  
10 bolts 45. In this manner, the split sleeve structures can be utilized as a common clamp and sleeve thereby facilitating the ease and manner in which the end edges of each screen may be secured to the spaced stanchions. Utilizing the split sleeve, not only are the band clamps 42  
15 not necessary to secure the end edges of each screen to a stanchion, but the opposing clamp members 40 are also not necessary as the end edges may be directly secured to the spaced and opposing flanges of the split sleeve.

With specific reference to Fig. 21, another embodiment  
20 of sleeve 44b is shown. In this embodiment, the sleeve is extrusion molded to provide a pair of spaced flanges 48 which extend outwardly from an integral tubular body 49. In this embodiment, the end edges of a screen may be secured between the flanges 48 either by separate fasteners such as  
25 bolts 45, ultra-sonic welding or adhesively securing the end edges between the spaced flanges 48. In some embodiments a single flange 48 may be used.

Regardless of the manner in which the end edges of each screen 32 are secured to the sleeves, when the screens are

secured, they are generally rigid between the spaced stanchions so as not to yield laterally, sag, stretch or otherwise be displaced by wave or tidal activity.

With specific reference to Fig. 1, in some deployments, it is possible that some screens may be of such a length as to require an intermediate support between sleeves mounted on spaced stanchions. In this respect, either secondary stanchions or supplemental posts 50 may be provided intermediate the normally deployed stanchions. An intermediate portion of the screen between its opposite ends may be secured to the supplemental post or stanchion 50. In Fig. 1, a first manner in which the screens may be secured to an intermediate stanchion is by interweaving the stanchion between enlarged openings 60 formed in the screen. In such instances, during manufacture, openings can be formed in vertical alignment which are of a size to allow the screen to be interweaved about the stanchion 50 when installed. This will allow the intermediate stanchion 50 to provide extra support for the screen without requiring mechanical fasteners.

As opposed to using an interweaving to secure the intermediate portion of a screen to an intermediate stanchion, and as shown in Figs. 6-8, plastic or metal locking ties or fasteners 52 may be used. As shown in Fig. 6, a generally flexible locking tie 52 extends around a sleeve 44 mounted to an intermediate post or stanchion. The opposite ends of the fastener 52 are enlarged as shown at 53 such that they can be inserted within the elongated openings 36 and thereafter rotated 90° in order to prevent withdrawal of the ends 53 through the openings 39. In this respect,

the intermediate body portion 54 of the fasteners 52 must permit a twisting motion to be applied without destroying the integrity of the fasteners.

The stanchions and the screen grids of the invention may be deployed in a generally linear alignment as shown in Figs. 1 and 2 or the separate screen grids 32 may be deployed in a somewhat staggered manner as shown in Figs. 22 and 23. In this embodiment the stanchions are deployed in sets including at least two end stanchions 31' and 31 and 31 and 31". Although not shown in the drawing figure, intermediate stanchions may be used between each of the end stanchions. As shown, the first screen grid extending from the shoreline is not in exact alignment with the second screen grid although, in some embodiments it may be.

To further rigidify the drawing structure as shown in Figs. 22 and 23, the adjacent stanchions 41 of the separate screen grids 32 may be connected such as by adjustable band clamps 56 and 57. The band clamps 56 are shown as being placed about the intermediate stanchions 31 which are adjacent to one another and, in some embodiments, other band clamps may be placed along the lower portion of the stanchion. In the drawing figure, a separate band clamp 57 is shown as being mounted about the sleeves of the adjacent stanchions 31. In some embodiments a plurality of secondary clamps may be used to secure the adjacent stanchions to one another. By connecting or securing the adjacent stanchions to one another a force directed against one stanchion is offset by the adjacent stanchion thereby further rigidifying and reinforcing the overall groyne structure.

With specific reference to Figs. 9-13, variations of screen grids are illustrated. It should be noted that the openings 39 in the grids may be elongated and somewhat oblong as shown in Fig. 9 in a vertical direction or may be elongated in a horizontal direction as shown in Fig. 1. Further, the dimension of the openings may vary such as shown in Figs. 9-13 or the openings may be non-uniform as exemplified by a further embodiment of the invention shown in Fig. 14.

The structure shown in Figs. 11 and 13 provide somewhat rectangular openings. Such grid structures are generally biaxial loaded so as to provide the same strength horizontally as vertically whereas structures such as shown in Figs. 9 and 10 tend to be somewhat uniaxially loaded so as to provide greater strength in one direction over another. As shown in Fig. 12, some of the screen grid structures are molded or extruded so that they are reinforced at intersections of their horizontal and vertical components as shown at 55 in the drawing figure.

With particular reference to Fig. 14, another embodiment of the present invention is shown in greater detail. In this embodiment, each of the screens is divided into a plurality of vertical sections 32a, 32b, and 32c respectively. As shown, the openings 39a, 39b and 39c in the three vertically related screen sections are of differing size and configuration. Generally, it would be preferred that the openings 39a be smaller and therefore more dense than the number of openings in the screen sections 32b and 32c. Although three sections are shown in the drawings figures, two or more sections may be used.

To facilitate the vertical movement of each of the screen sections, the end edges 35a and 36a of screen section 32a are mounted to separate spaced sleeves 44a whereas the end edges 35b and 36b of section 32b are mounted to a  
5 separate sleeves 44b. Likewise, the ends 35c and 36c of the uppermost screen section 32c are mounted to uppermost sleeves 44c.

With this embodiment, if it becomes necessary to elevate the screens, the uppermost screens can be removed  
10 once they are no longer needed leaving the lower screens in place such that the lower screens rest along newly deposited material.

As opposed to utilizing a plurality of separate screen sections to create different mesh openings, the present  
15 invention also contemplates creating different mesh openings by mounting separate screen grids in overlapping or face-to-face relationship. In this respect, in Figs. 17-19, a groyne structure 130 is shown wherein a secondary screen 132 having smaller mesh openings 139 is clamped in face-to-face  
20 relationship along the lower portion of a primary screen grid 32. By clamping the screens together in a manner as disclosed with respect to the previous embodiments, the openings along the lower portion of the screen can be varied as is needed. In the embodiment, the screens are shown as  
25 being clamped to the stanchions using split sleeves.

Although not shown in the drawings, but as previously discussed, each screen grid may also be formed with mesh openings of different sizes such that the density of the openings decreases from the bottom to top with the smallest

openings therefore being along the lower portion thereof.

In use, the material from which the screens of the invention are made allows the groynes to be left in place after deployment for indefinite periods of time. The  
5 material is strong enough to withstand heavy storm surges and will not deteriorate by exposure to salt water or to ultra-violet light. As waves pass through the openings created within the screens, particulate material will be deposited along the base of the screen. As material  
10 continues to build-up, it is also possible to selectively elevate the screens and/or the stanchions of the present invention such that the bottom of the screens can be adjusted so as to be positioned adjacent an upper surface of newly deposited materials. The structure can also be easily  
15 removed once a predetermined amount of material has been reclaimed.

The structure of the groynes of the present invention provides an advantage over prior art structures in that the screens are not easily damaged as are screens which are  
20 formed of more conventional flexible netting material. Therefore, there are fewer costs involved with maintenance of a deployed groyne.

With specific reference to Figs. 24 and 25, a further embodiment of the present invention is shown wherein the  
25 screens and stanchions are used to create a porous breakwater 200. The breakwater differs in its deployment and its purpose from the porous groynes. The breakwater is provided so as to extend somewhat parallel to a seashore "S" to create a barrier which breaks wave action and, thereby

reduces the damaging effect of wave impact on material along the shoreline. With the present invention, the screen material is sufficiently strong and yet may be made selectively porous to create a desired dissipation of wave energy. The structure includes a plurality of stanchions or posts 31 which are embedded in spaced relationship along a line extending generally parallel to the seashore as shown. Thereafter, utilizing the mounting elements of the present invention as previously described, the screens 32 are secured to the stanchions such that they extend generally to the high tide line although in some instances the structure may be constructed so as to be deployed below the normal low tide line but spaced outwardly from the shore. As waves approach the shore they must pass through the openings 39 within the structure and, depending upon the size of the openings, the energy of the wave action can be reduced thereby further facilitating beach build-up by reducing the effect that normal wave action would have with respect to material along the shoreline.

The foregoing description of the preferred embodiment of the invention has been presented to illustrate the principles of the invention and not to limit the invention to the particular embodiment illustrated. It is intended that the scope of the invention be defined by all of the embodiments encompassed within the following claims and their equivalents.

1. A porous groyne for land reclamation comprising a plurality of pairs of spaced end stanchions and a plurality of screen grid means, each of said screen grid means having  
5 an upper portion, lower portion and opposite ends and having a plurality of openings therein through which fluid and fluid conveyed solids may pass, said screen grid means being formed of a self supporting material formed of high density polyethylene, polypropylene, polymers, co-polymers, polymer  
10 mixtures or laminates thereof which is formed to create said plurality of openings therein, and means for securing said opposite ends of each of said screen grid means relative to a separate pair of said plurality of pairs of said end stanchions such that said screen grid means are  
15 substantially rigid between said end stanchions.

2. The porous groyne of claim 1 including at least one intermediate stanchion positioned between at least one of said pairs of end stanchions to which one of said screen grid means may be selectively secured.

20 3. The porous groyne of claim 2 wherein at least one of said screen grid means includes a plurality of second openings therein of a size to selectively receive said at least one intermediate stanchion such that said at least one screen grid means may be secured by interweaving said at  
25 least one intermediate stanchion through said secondary openings.

4. The porous groyne of claim 2 including means for selectively securing said one of said screen grid means to



said at least one intermediate stanchion.

5. The porous groyne of claim 1 in which said means for securing said plurality of screen grid means includes at least one sleeve means mounted to each of said end  
5 stanchions, said sleeve means being of the size to be slidably movable with respect to said end stanchions, and means for securing said opposite ends of said screen grid means to said sleeves.

6. The porous groyne of claim 5 wherein at least one  
10 of said sleeve means formed as a split sleeve having a tubular body member having a pair of spaced integrally formed flanges in spaced relationship with respect to one another between which an end of one of said screen means may be disposed.

7. The porous groyne of claim 5 wherein at least one  
15 of said sleeve means includes a tubular body portion having at least one flange element extending outwardly therefrom to which an end of a screen grid means may be secured.

8. The porous groyne of claim 1 in which at least one  
20 of said screen grid means includes a plurality of non-uniform openings and wherein openings adjacent said lower portion are smaller in dimension than those adjacent said upper portion.

9. The porous groyne of claim 1 in which at least one  
25 of said screen means includes a plurality of vertical sections, and means for independently mounting each of said vertical sections to said spaced end stanchions whereby said

vertical sections are independently movable relative to said end stanchions.

10. The porous groyne of claim 1 wherein at least one of said screen means includes a pair of screen means mounted  
5 in opposing and face-to-face relationship in such a manner that openings in each of said screen means are aligned relative to one another in facing relationship to thereby vary an effective opening size between said pair of screen grid means.

10 11. The porous groyne of claim 1 wherein a first stanchion of a first of said plurality of pairs of end stanchions is disposed proximate to a second stanchion of a second of said plurality of pairs of end stanchions, and means for connecting said first and second stanchions to one  
15 another.

12. A porous groyne for land reclamation comprising a plurality of spaced stanchions and at least one screen grid means, said at least one screen grid means having an upper portion, lower portion and opposite ends and having a  
20 plurality of openings therein through which fluid and fluid conveyed solids may pass, said screen grid means being formed of a self supporting material formed of high density polyethylene, polypropylene, polymers, co-polymers, polymer mixtures or laminates thereof which is formed to create said  
25 plurality of openings therein, means for vertically securing said opposite ends of said at least one screen grid means relative to spaced stanchions such that said at least one screen grid means is substantially rigid between said end stanchions.

13. The porous groyne of claim 12 in which said means  
for securing said at least one screen grid means includes at  
least one sleeve means mounted to each of said stanchions,  
5 said sleeve means being of the size to be slidably movable  
with respect to said stanchions, and means for securing said  
opposite ends of said at least one screen grid means to said  
sleeves.

14. The porous groyne of claim 12 in which said screen  
10 grid means are formed of a Tensar Geo-grid® material.

15. The porous groyne of claim 1 in which said screen  
grid means are formed of a Tensar Geo-grid® material.

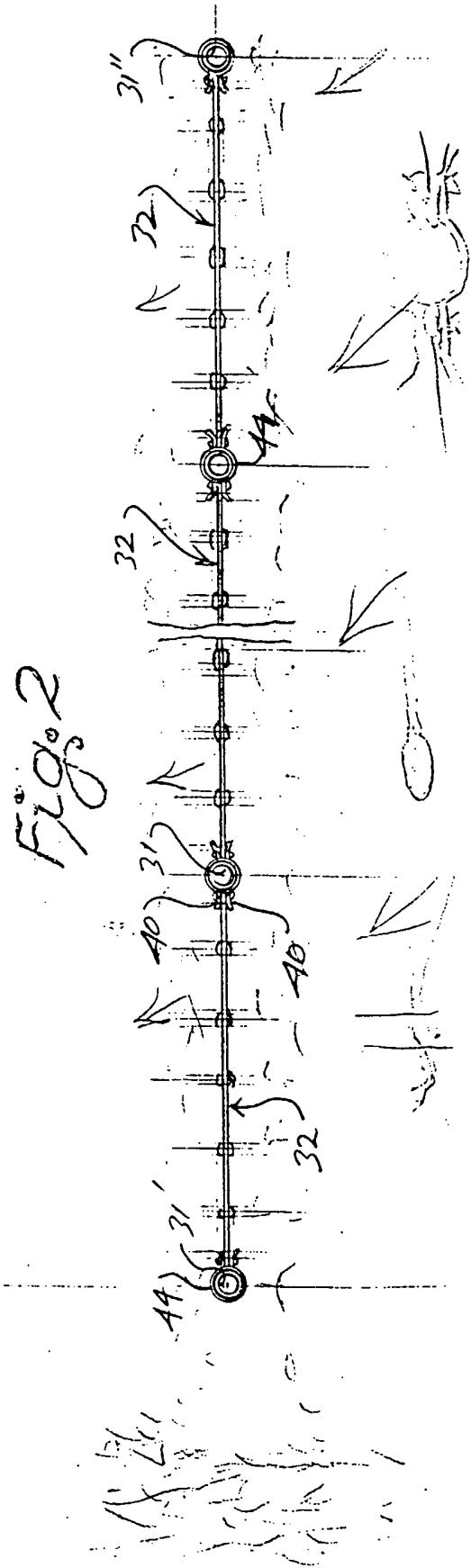
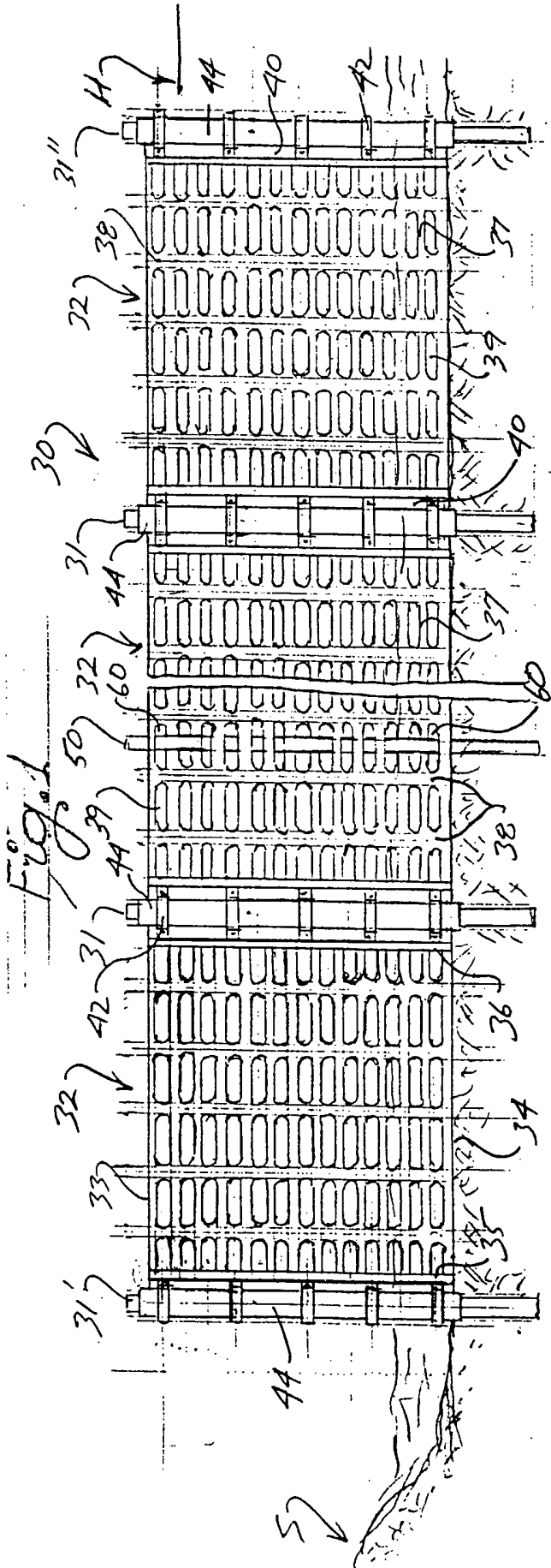

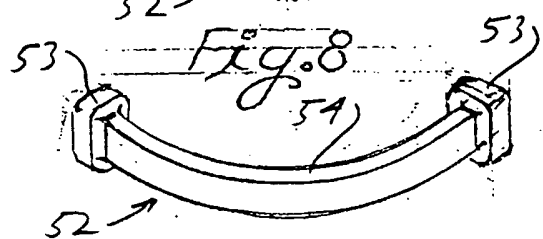
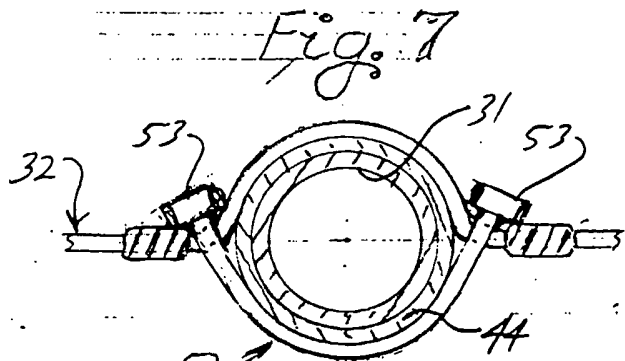
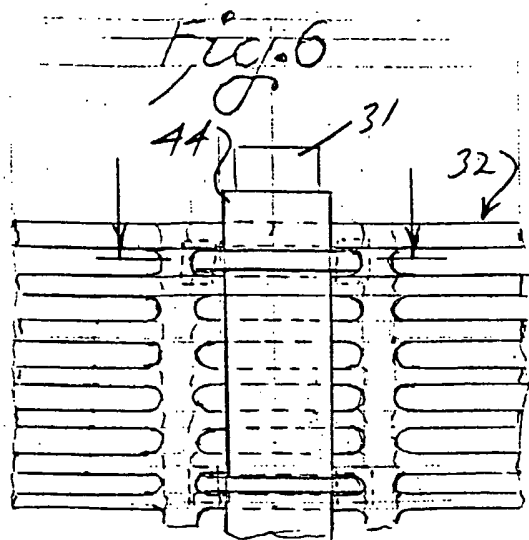
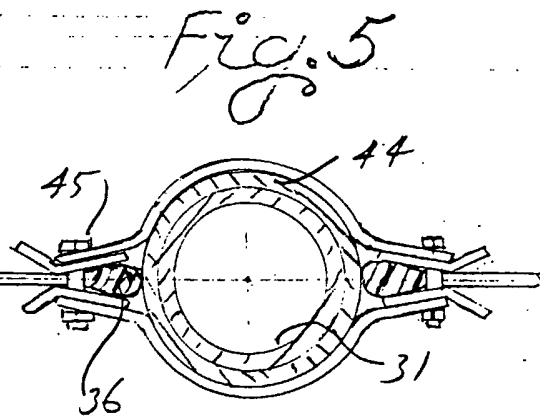
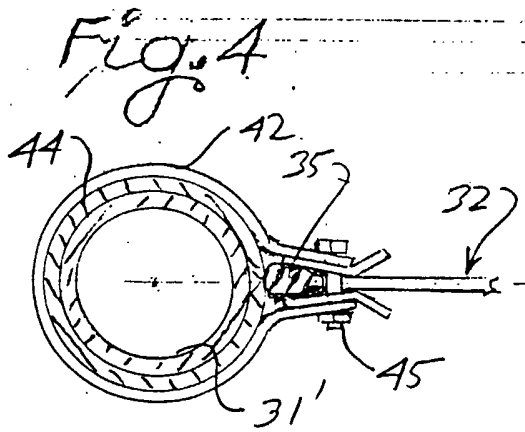
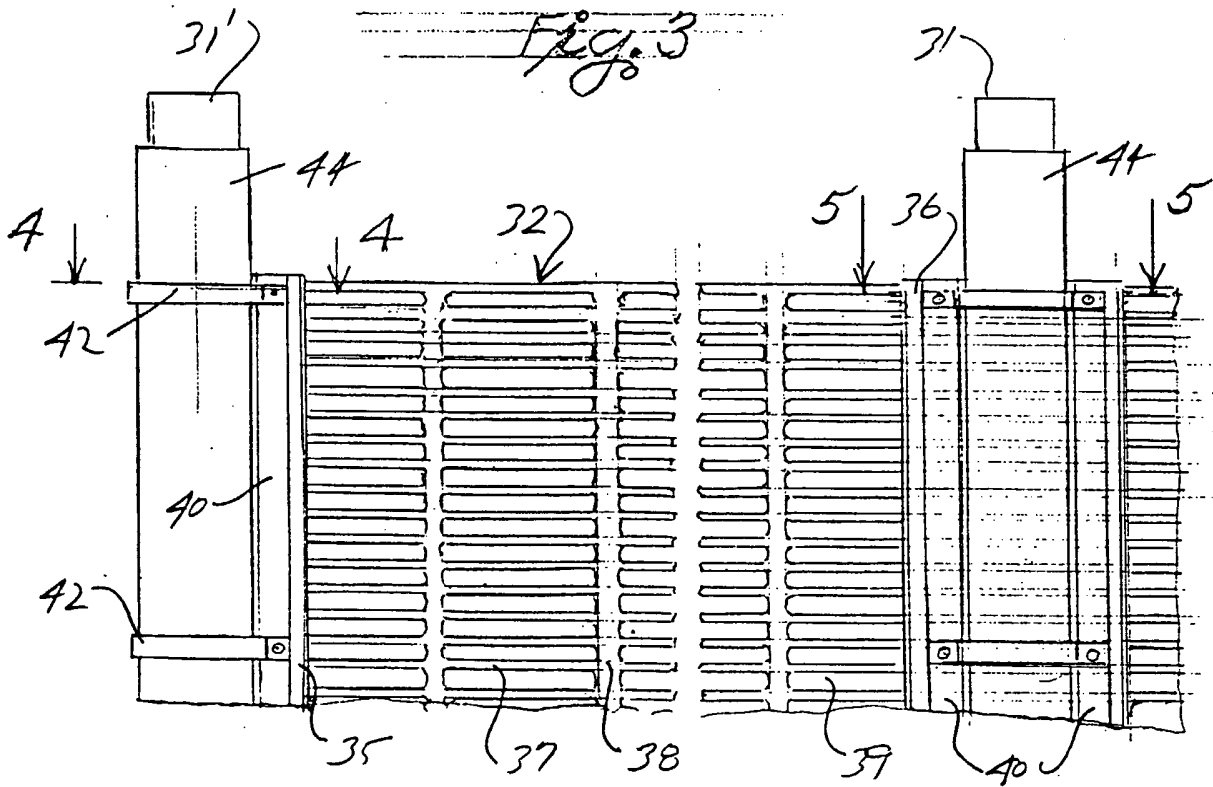

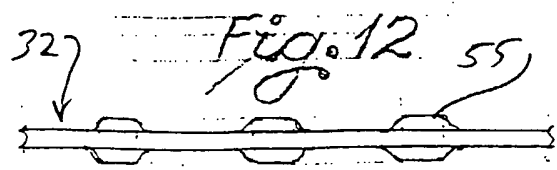
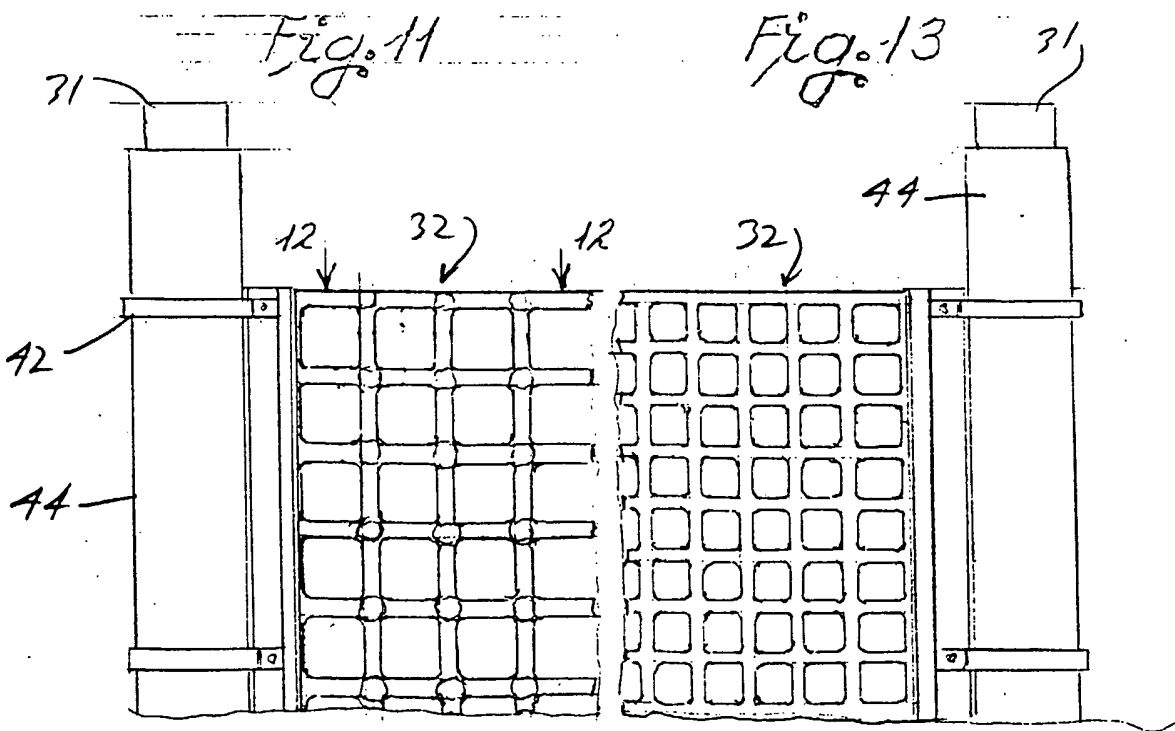
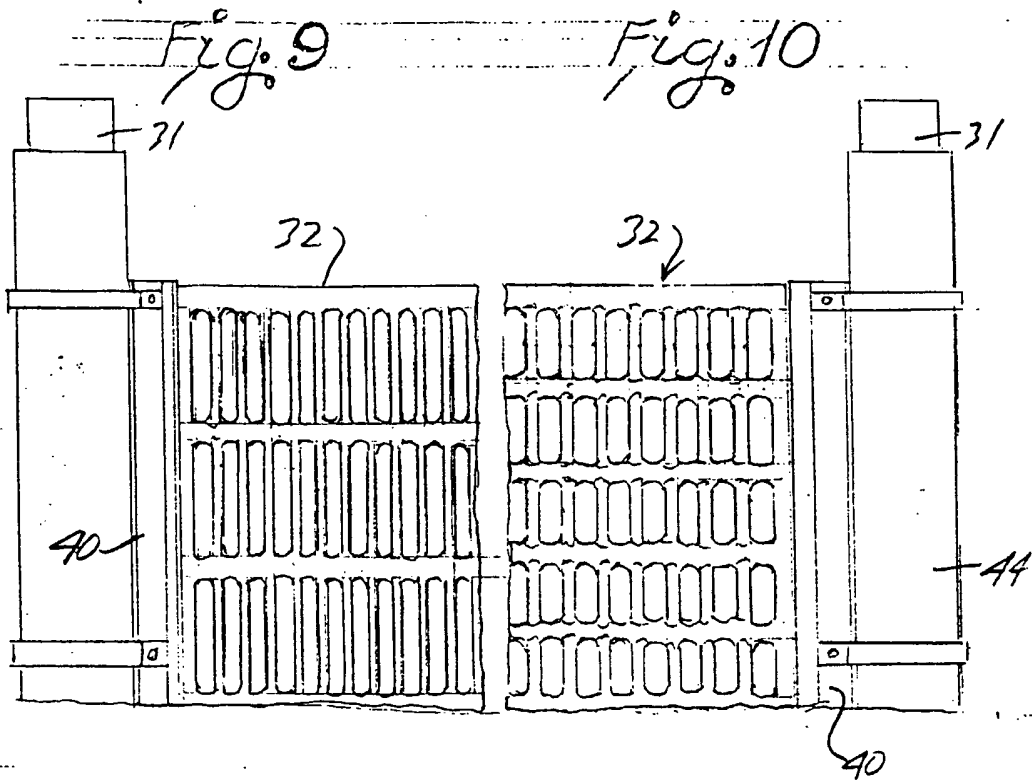

Fig. 1A

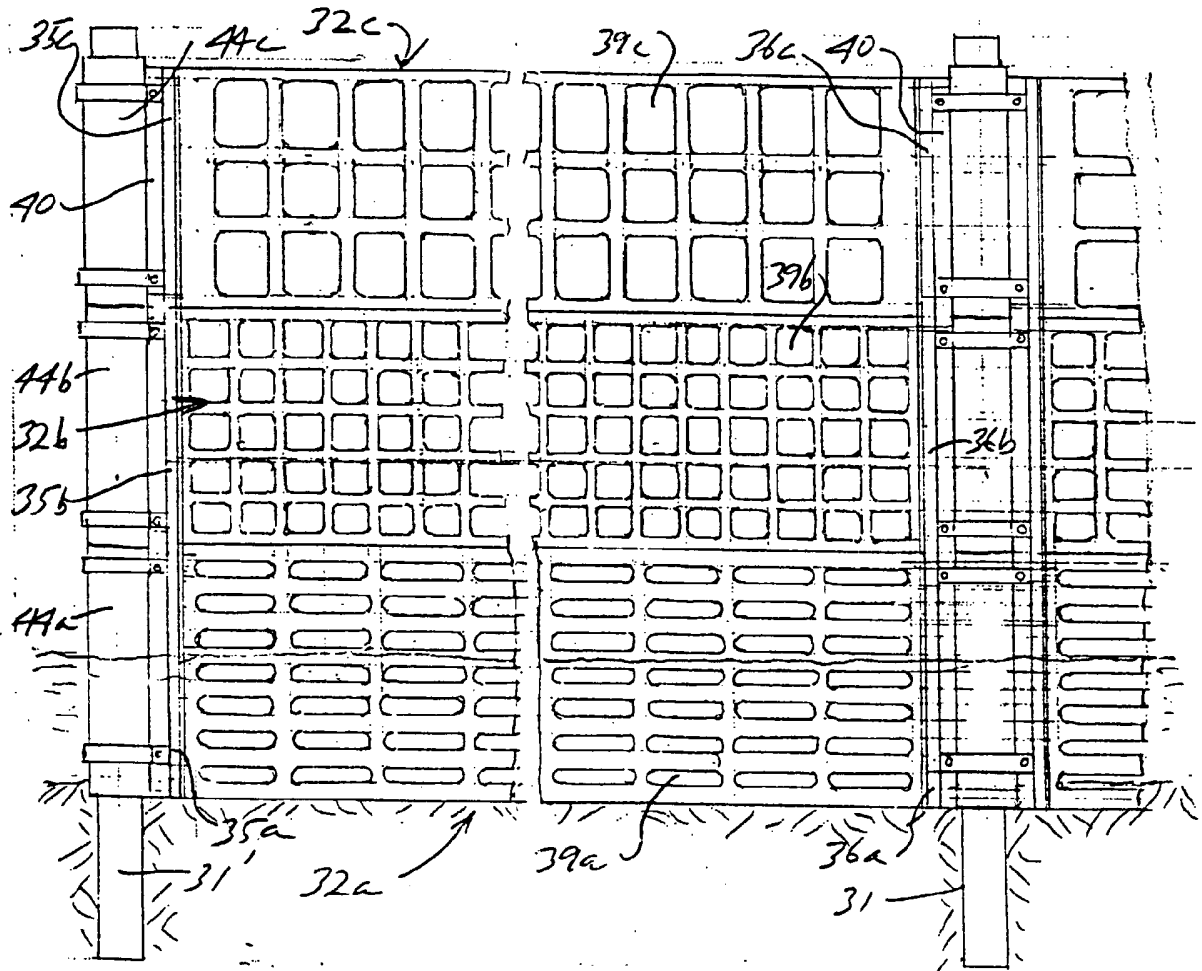

Fig. 15

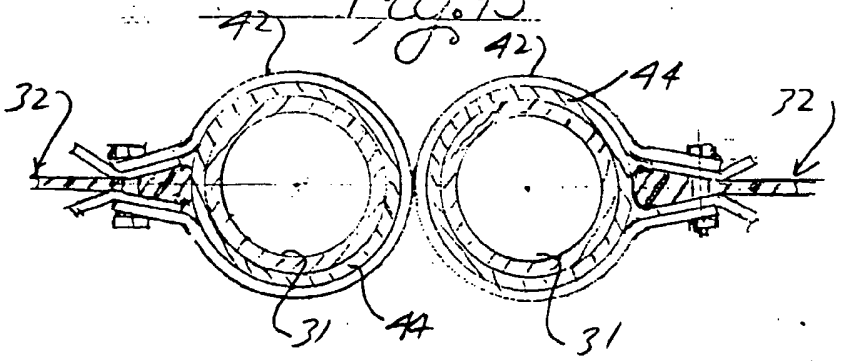
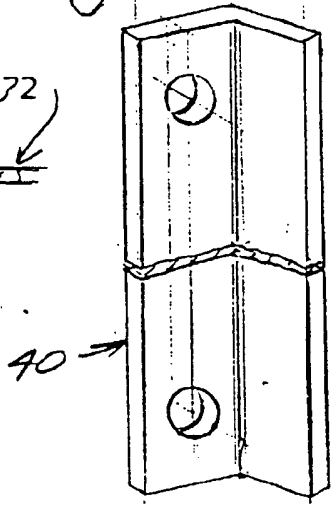
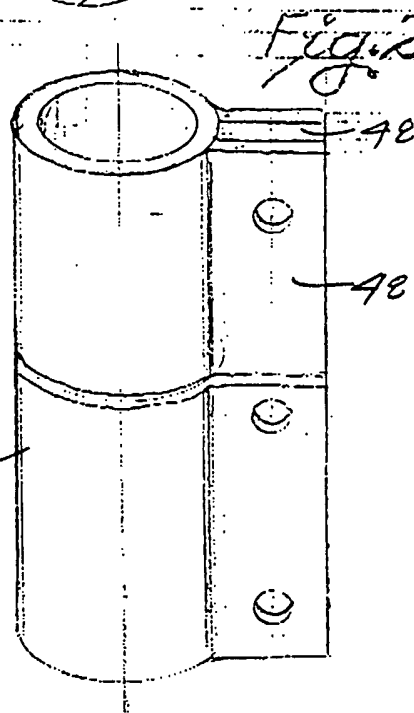
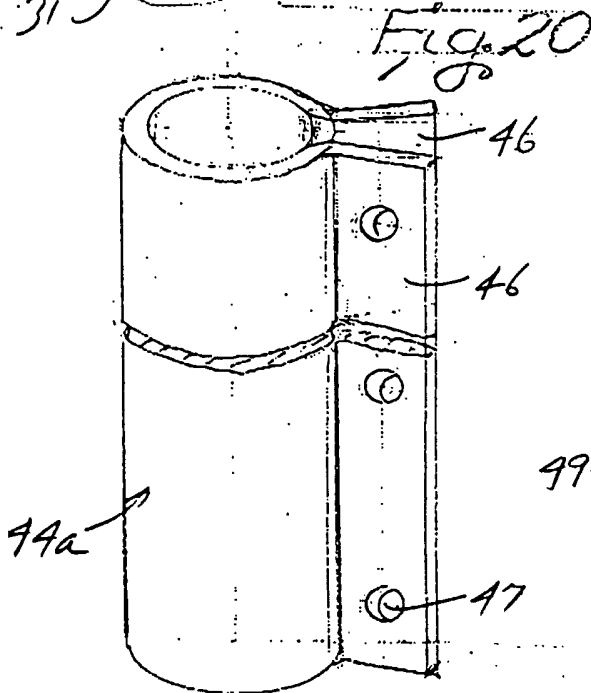
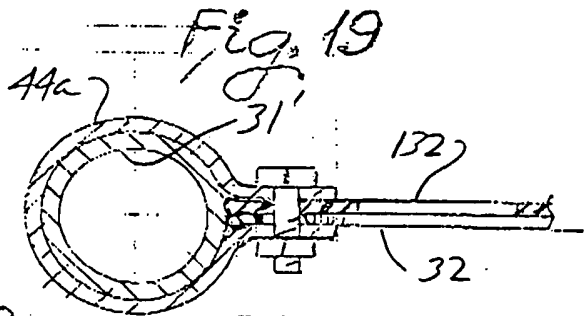
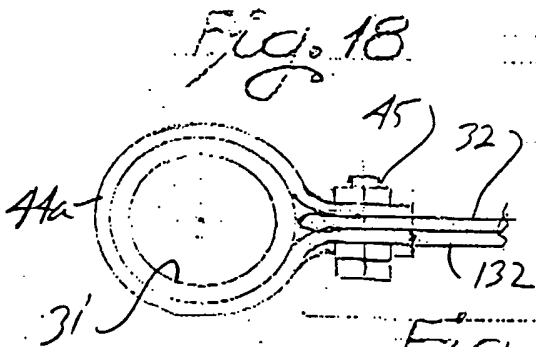
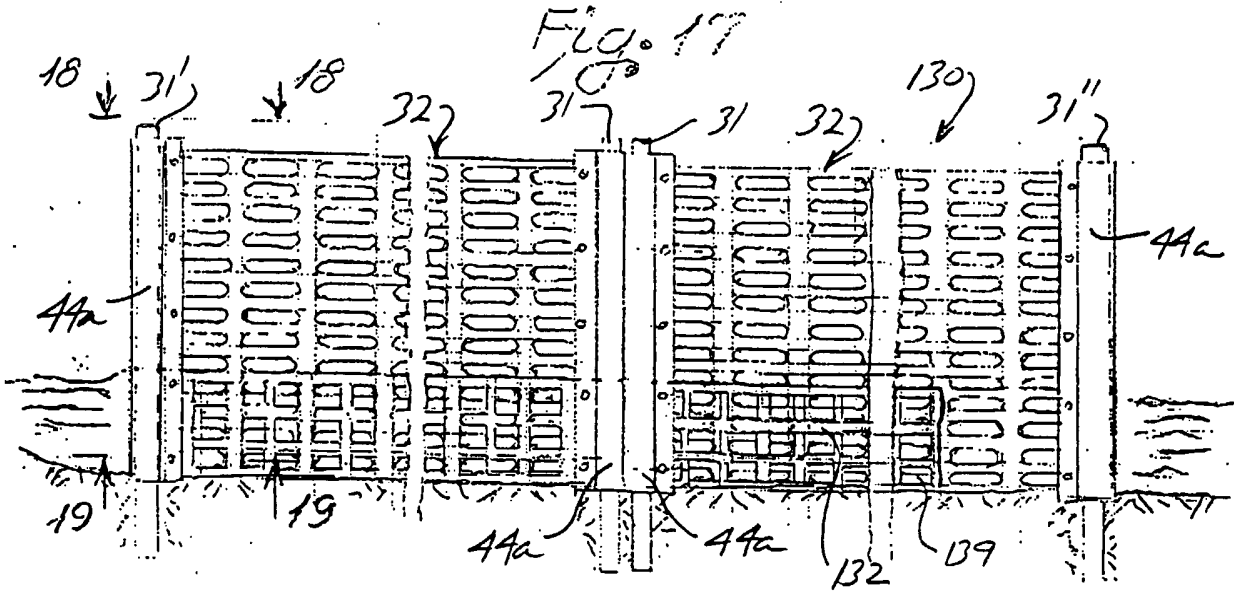

Fig. 16







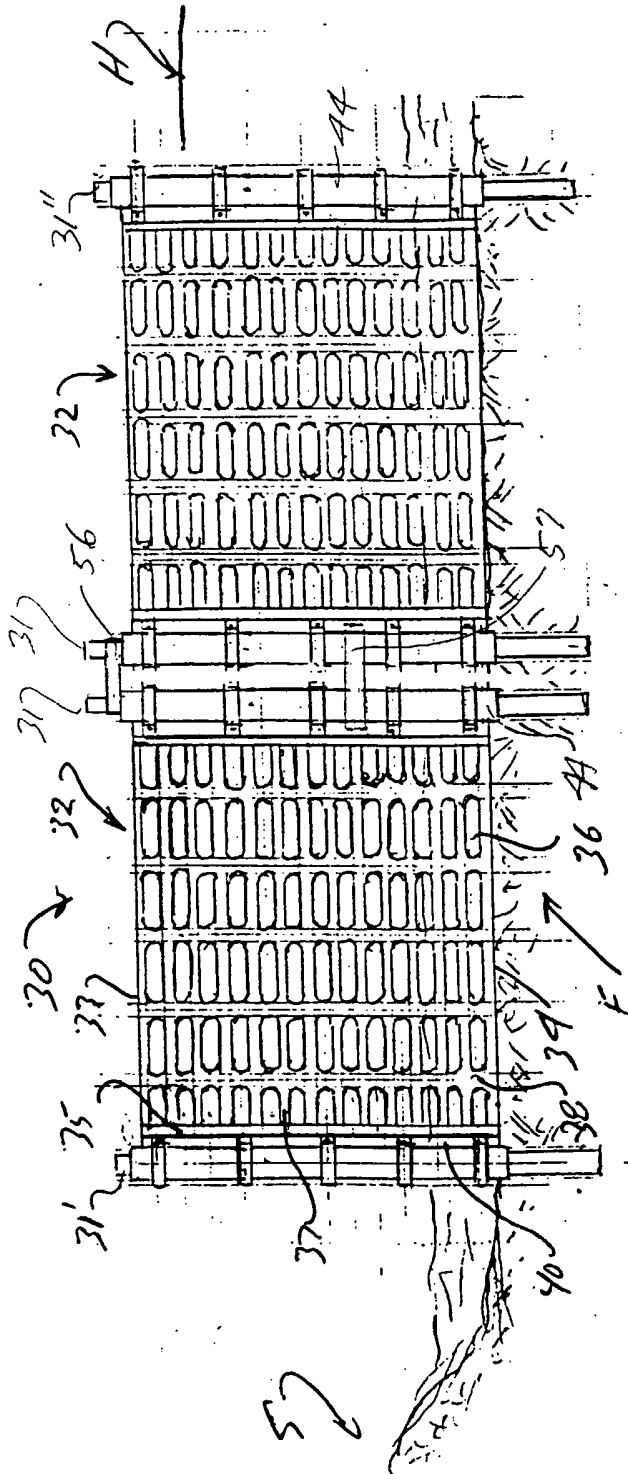

Fig. 22

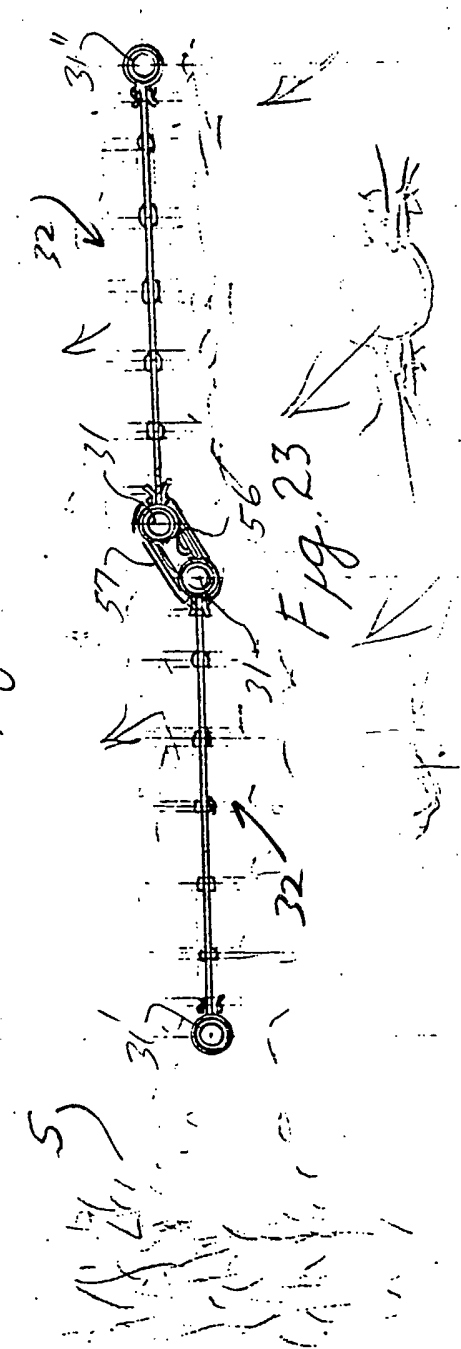
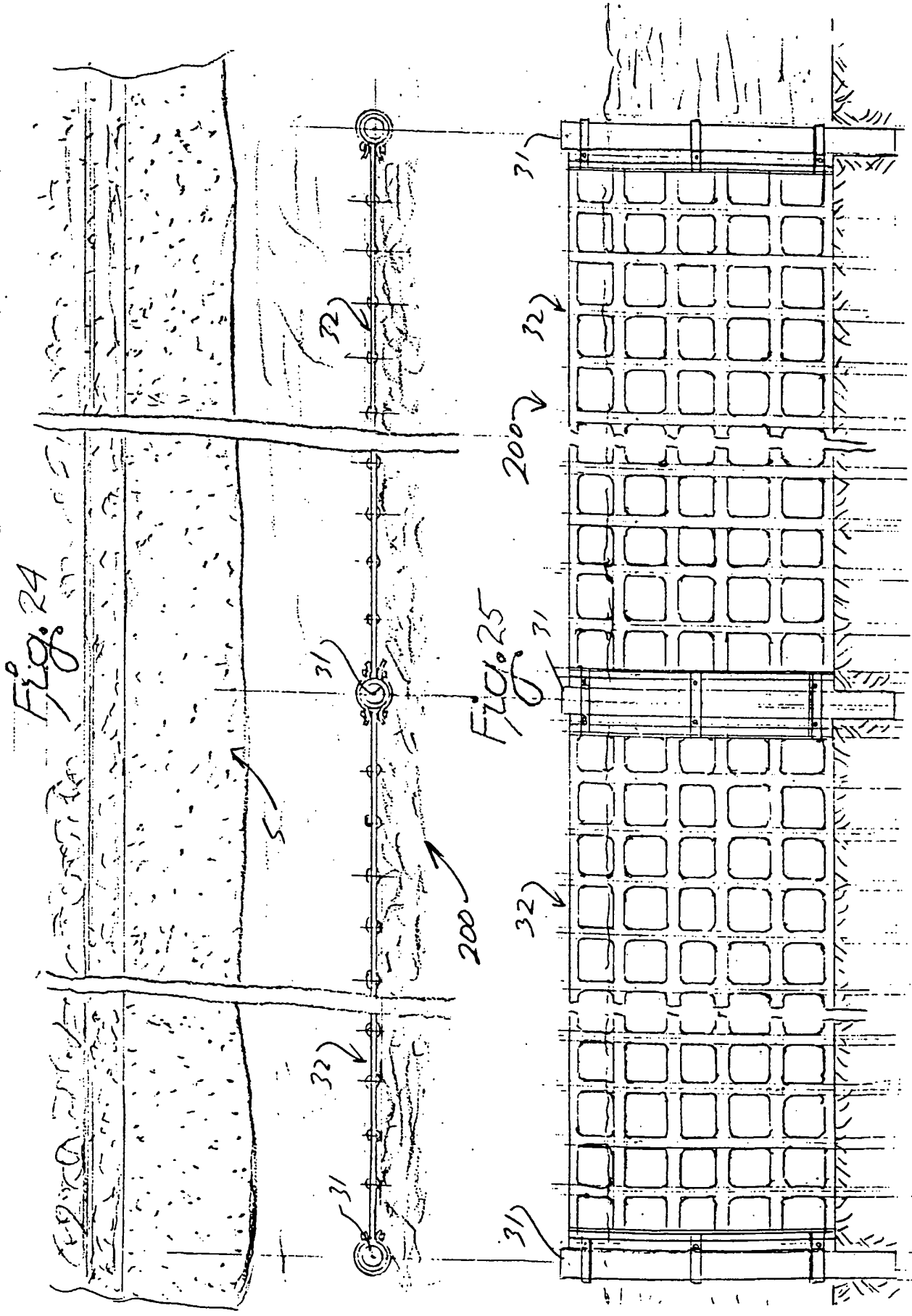

Fig. 23



INTERNATIONAL SEARCH REPORT

International application No.  
PCT/US02/14423

**A. CLASSIFICATION OF SUBJECT MATTER**  
 IPC(7) : E02B 3/06  
 US CL : 405/32, 21, 15, 302.6, 302.7; 256/12.5  
 According to International Patent Classification (IPC) or to both national classification and IPC

**B. FIELDS SEARCHED**  
 Minimum documentation searched (classification system followed by classification symbols)  
 U.S. : 405/32, 21, 15, 302.6, 302.7, 22, 24, 25, 28, 35; 256/12.5

Documentation searched other than minimum documentation to the extent that such documents are included in the fields searched

Electronic data base consulted during the international search (name of data base and, where practicable, search terms used)

**C. DOCUMENTS CONSIDERED TO BE RELEVANT**

Category *	Citation of document, with indication, where appropriate, of the relevant passages	Relevant to claim No.
X --- Y	US 5,255,997 A (BAILEY ET AL) 26 OCTOBER 1993 (26/10/1993), SEE ENTIRE DOCUMENT AND FIGURES 11 AND 12.	1, 2, 4-8, AND 11-13 ----- 3, 9, 14, AND 15
Y	US 4,738,563 A (CLARK) 19 APRIL 1988 (19/04/1988), SEE COLUMNS 3-4, LINES 65-10.	3
Y	US 4,089,179 A (TRAUTMAN) 16 MAY 1978 (16/05/1978), SEE COLUMN 2, LINES 23-68.	9
Y	US 5,277,520 A (TRAVIS) 11 JANUARY 1994 (11/01/1994), SEE COLUMN 8, LINES 27-49.	14 AND 15

Further documents are listed in the continuation of Box C.  See patent family annex.

* Special categories of cited documents:	"T"	later document published after the international filing date or priority date and not in conflict with the application but cited to understand the principle or theory underlying the invention
"A" document defining the general state of the art which is not considered to be of particular relevance	"X"	document of particular relevance; the claimed invention cannot be considered novel or cannot be considered to involve an inventive step when the document is taken alone
"E" earlier application or patent published on or after the international filing date	"Y"	document of particular relevance; the claimed invention cannot be considered to involve an inventive step when the document is combined with one or more other such documents, such combination being obvious to a person skilled in the art
"L" document which may throw doubts on priority claim(s) or which is cited to establish the publication date of another citation or other special reason (as specified)	"&"	document member of the same patent family
"O" document referring to an oral disclosure, use, exhibition or other means		
"P" document published prior to the international filing date but later than the priority date claimed		

Date of the actual completion of the international search: 28 June 2002 (28.06.2002)  
 Date of mailing of the international search report: 23 SEP 2002

Name and mailing address of the ISA/US: Commissioner of Patents and Trademarks, Box PCT, Washington, D.C. 20231, Facsimile No. (703)305-3230  
 Authorized officer: Frederick L. Lagman, Telephone No. 703-305-7456