

V. DAELEN.

MACHINE FOR ROLLING METAL CYLINDERS.

No. 323,281.

Patented July 28, 1885.

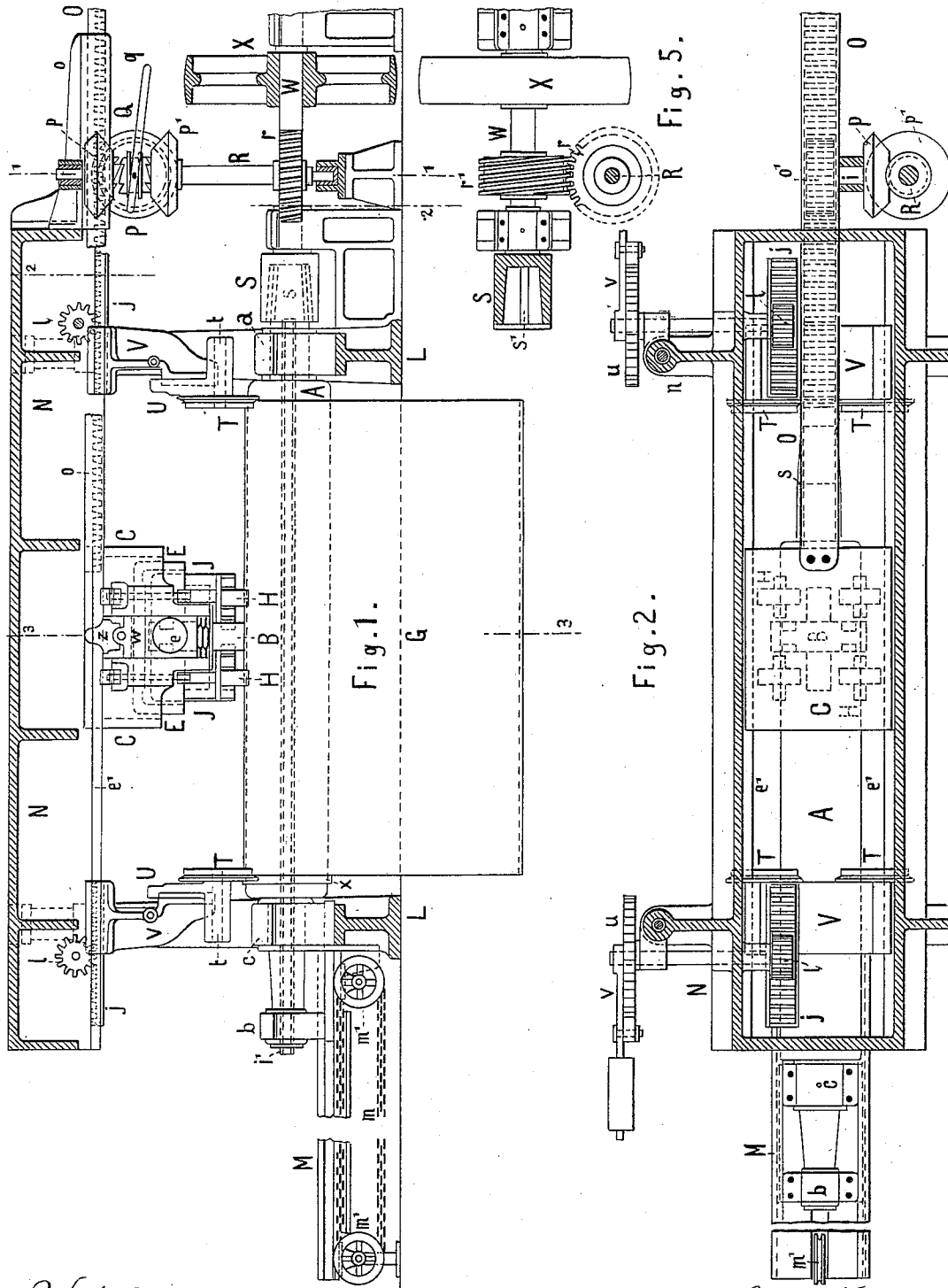

Witnesses,
 Edward Stear
 Geo. S. Wheelock

Inventor,
 Vital Daelen,
 By *King* 3703
 his Attorney

(No Model.)

6 Sheets—Sheet 2.

V. DAELÉN.

MACHINE FOR ROLLING METAL CYLINDERS.

No. 323,281.

Patented July 28, 1885.

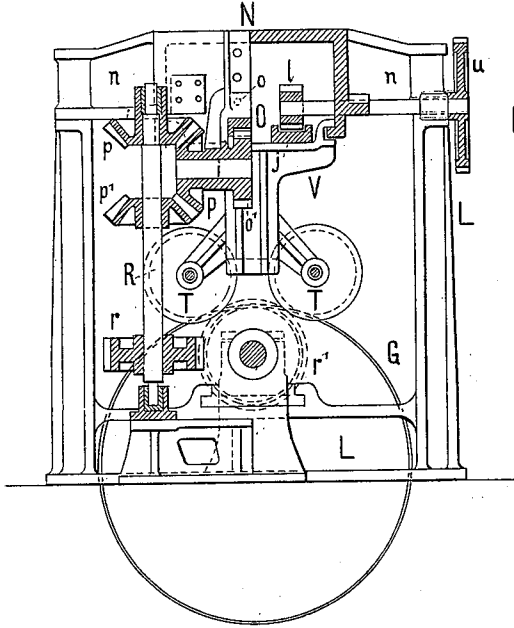

Fig. 3.

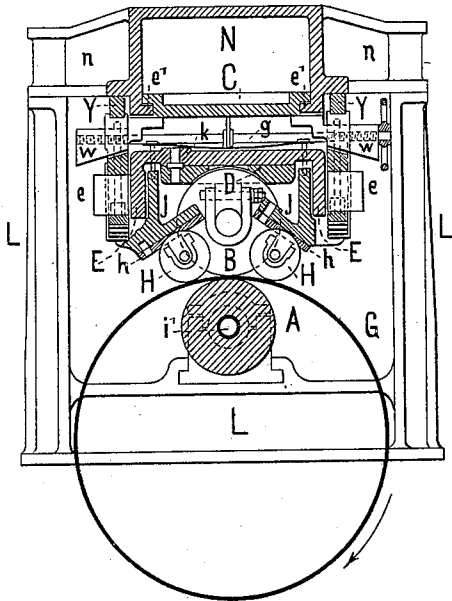

Fig. 4.

Witnesses
Edward Steer.
Geo. Wheelock.

Inventor:
Vital Daelén
By *Knights* 1885
his atty.

V. DAELLEN.

MACHINE FOR ROLLING METAL CYLINDERS.

No. 323,281.

Patented July 28, 1885.

Fig. 6.

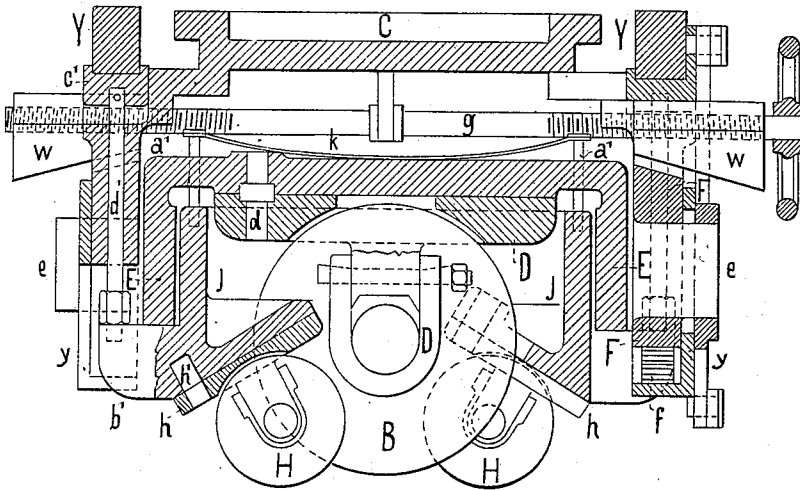
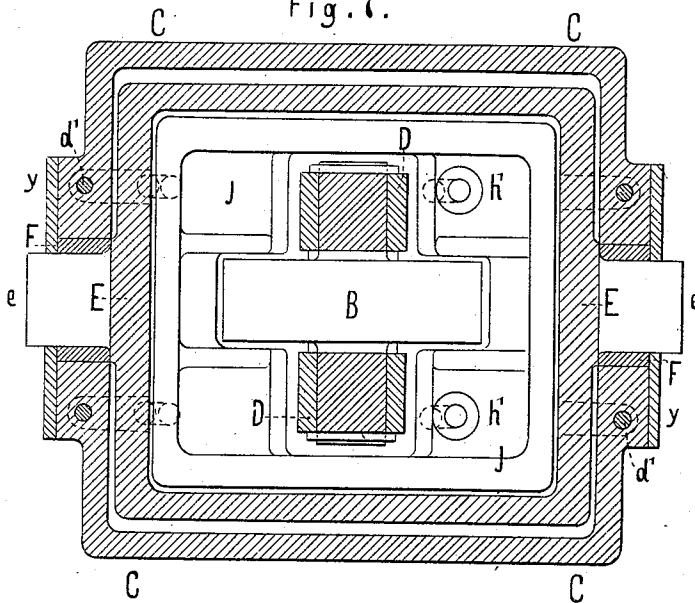

Fig. 7.



Witnesses
 Edward Steer
 Geo. Wheelock

Inventor
 Vital Daellen
 By Knight Bros
 his Atty

V. DAELEN.

MACHINE FOR ROLLING METAL CYLINDERS.

No. 323,281.

Patented July 28, 1885.

Fig. 8.

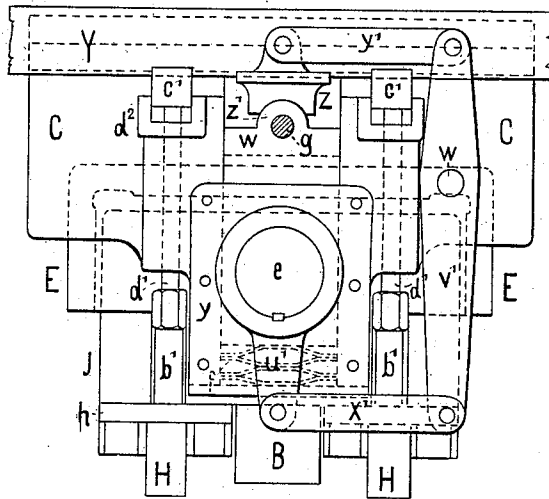
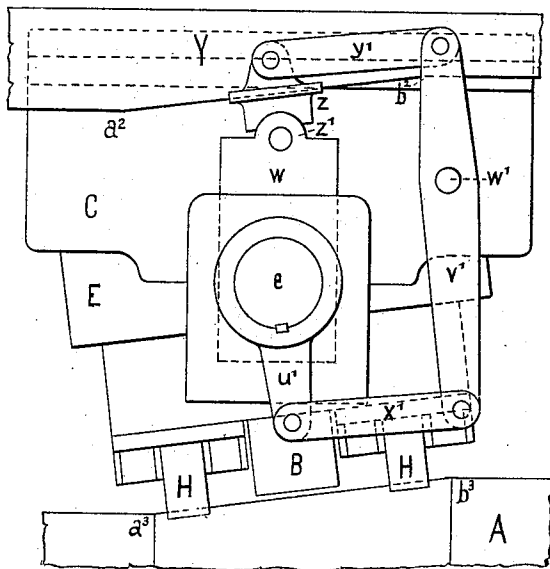

Fig. 9.



Witnesses
 Edmund Steen
 Geo. Wheelock

Inventor
 Vital Daelen
 By Knight & Co.
 His Atty

V. DAELLEN.

MACHINE FOR ROLLING METAL CYLINDERS.

No. 323,281.

Patented July 28, 1885.

Fig. 10.

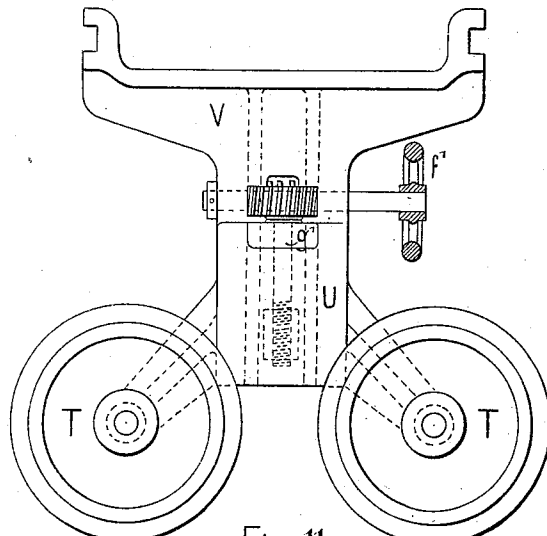

Fig. 11.

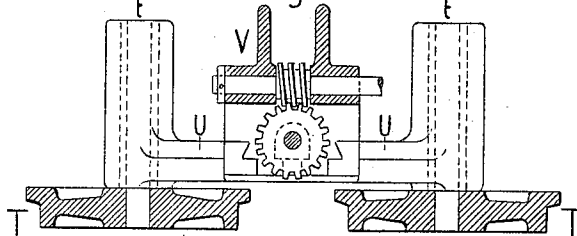
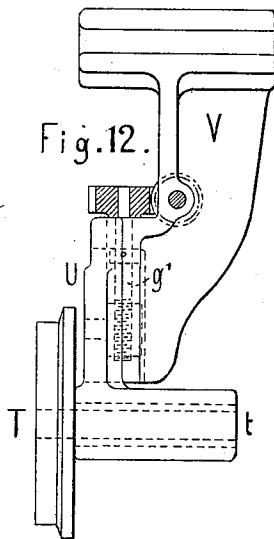

Fig. 12.



Witnesses
Edward Stein
Geo. S. Wheelock

Inventor
Vital Daelen
 By *Knights Bros*
his Atty

V. DAELEN.

MACHINE FOR ROLLING METAL CYLINDERS.

No. 323,281.

Patented July 28, 1885.

Fig. 15.

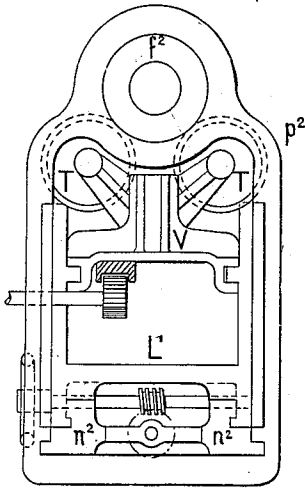

Fig. 13.

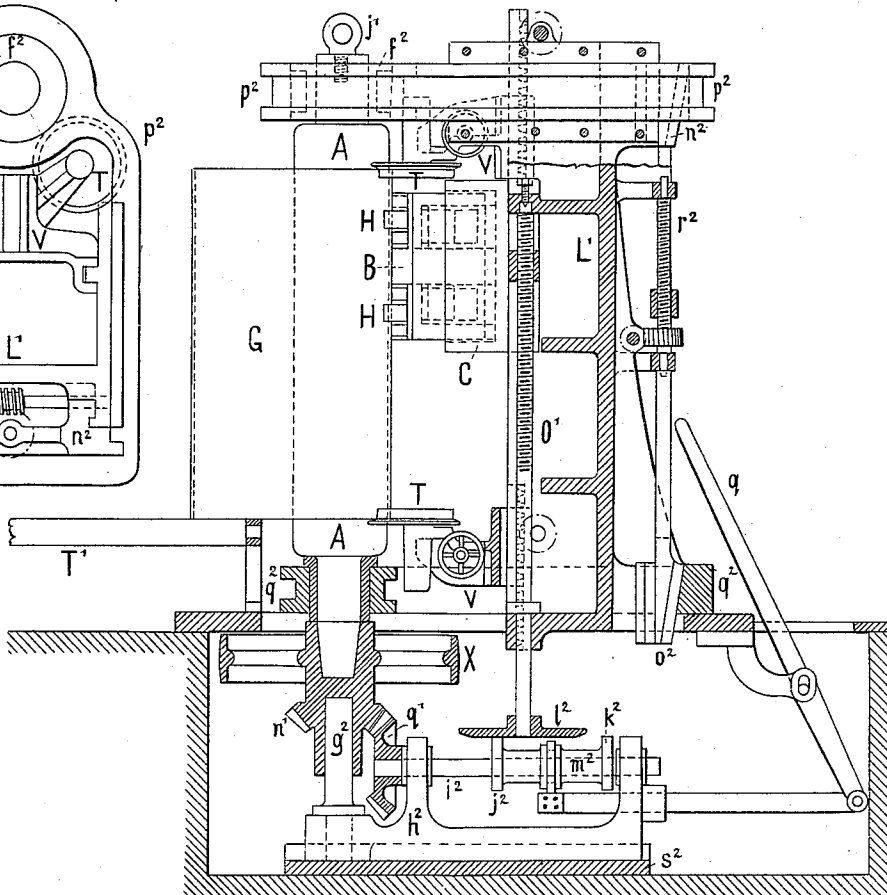
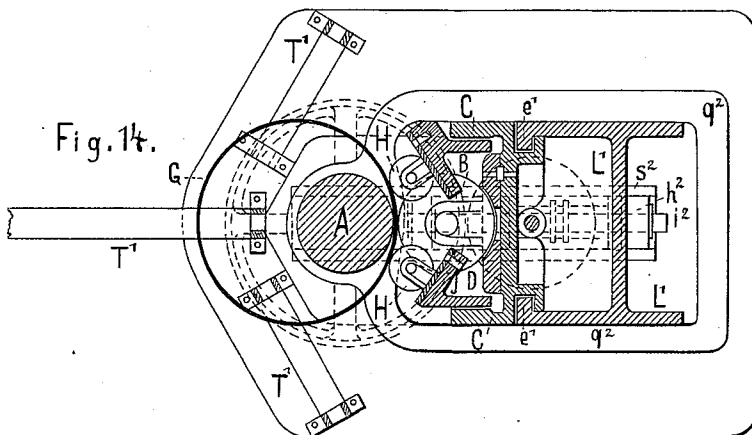

Fig. 14.



Witnesses:
 Edward Stead
 Geo. Wheelock

Inventor:
 Vital Daelen
 By Knight Bros
 his Atty

UNITED STATES PATENT OFFICE.

VITAL DAELLEN, OF BERLIN, GERMANY.

MACHINE FOR ROLLING METAL CYLINDERS.

SPECIFICATION forming part of Letters Patent No. 323,281, dated July 28, 1885.

Application filed September 27, 1884. (No model.) Patented in England September 8, 1884, No. 12,141.

To all whom it may concern:

Be it known that I, VITAL DAELLEN, of Berlin, 21 Chausseestrasse, Prussia, German Empire, engineer, have invented a new and useful Improved Machine for Rolling Wrought-Iron or Steel Cylinders, of which the following is a specification.

My invention relates to the manufacture of large seamless cylinders of wrought-iron or steel for steam-boilers and other vessels, by means of a rolling process; and it substantially consists in a machine comprising a long roll adapted to be passed through the cylinder and to carry or support it, and a short roll acting from the outside on the cylinder and provided with means for being pressed against the same and moved lengthwise to and fro during the rolling operation.

A machine of this kind is represented on the annexed six sheets of drawings. Figure 1 is a sectional front elevation with the cylinder to be rolled in its place. Fig. 2 is a plan corresponding to Fig. 1, except that the cylinder is omitted and the long roll shifted to some extent from its working position. Fig. 3 is a sectional end view, partly on the line 1 1 and partly on the line 2 2, Fig. 1. Fig. 4 is a section on line 3 3, Fig. 1. Fig. 5 shows the driving-gear in plan. Figs. 6, 7, and 8 show the carriage C with the short roll B and guiding-roll H, respectively, in vertical transverse section, in horizontal section, and in front elevation. Fig. 9 represents the carriage C with certain parts thereof in different position, and a portion of a roll, A, with conical part. Fig. 10 is a side view, Fig. 11 a sectional plan, and Fig. 12 a front view, of the sliding carriage V, carrying the flanged guide-rolls T. Fig. 13 shows in vertical sectional elevation a modified arrangement of the rolling-machine. Fig. 14 is a sectional plan of the same, and Fig. 15 a top view, the latter figure being turned at right angles relatively to Fig. 14.

The long roll A, Figs. 1, 2, and 4, is carried at one end in the two bearings *b* and *c*, having a common foot-plate arranged to slide on and to be guided by ways M, and connected to a chain, *m*, which runs over the sprocket-wheels *m'*, so that when one of the said wheels is rotated the bearings *b* and *c* will be moved along

the ways M and the roll A withdrawn from the space between the two frames L, so that the cylinder to be rolled may then be brought into its place or removed therefrom. At its other end the roll A is supported during the rolling operation in the fixed bearing *a*. The journal *s* running in this bearing projects beyond the same with a conical part into the coupling-sleeve S, formed on the end of the driving-shaft W, and it is provided on the said part with grooves engaging with feathers *s'* in the sleeve, for the purpose of being rotated by the shaft W. X is the driving-pulley.

In order to prevent the roll A from being heated excessively, it may be made with a central boring, into which a pipe, *v*, projects for conducting water into the roll.

The short roll B, co-operating with the roll A, is carried by bearings D, (see Figs. 6, 7, 8,) having a common foot-plate, pivoted to a box, E, by means of a pin, *d*. This pin is vertical to the axis of the roll B, and it is placed in the transverse central plane of the roll, but rearward of the latter, so that during the rolling process the roll may swivel on *d*, while it has the tendency to return to its normal position—*i. e.*, the position in which its axis is parallel to the axis of the roll A. The said box E is carried by its trunnions *e* in brasses F, mounted in the carriage C so as to be vertically movable therein. These brasses are held in their place by plates *y*, and they are supported by springs *f*, while they may be pressed down by the wedges *w*, bearing with their upper side against blocks *x*, which in their turn abut against and are movable upon the guiding-bars Y, fixed to the top frame part, N. The wedges may be drawn toward each other to press the bearings F down and the roller B against the cylinder G by means of the screw-spindle *g*, working with right and left hand screw-threads in the wedges.

In addition to the roll B and its bearings the box E carries a frame, I, to which are connected, by pivots *h*, the four plates *h*, carrying in bearings the guide-rolls H. The pivots *h* are arranged in respect to the rolls H in a similar manner as the aforesaid pivot *d* is brought in relation to the roll B, so that the rolls H may swivel on the frame I. The bearing-sur-

faces for the plate *h* are preferably made inclined, so as to be approximately vertical to the radii of the cylinder G, which pass through the axles of the rolls H.

5 The frame I is suspended in the box E by the screws *a'* and springs *k*, and it can be adjusted higher or lower in respect to E by means of the nuts on the four screws *d'*, bearing on projecting parts *b'* of the frame I, while the screws are fastened with their ends to the pieces *c'*, abutting against the guiding-bar Y, and arranged to slide vertically between ledges *d''* on the carriage C. By the said screws the rolls H may thus be adjusted up or down independently of the roll B, so that they may be in contact with the cylinder G when the roll B is.

The carriage C is supported by guiding-edges *e'* on either side of the top part, N, of the main frame, and it is slowly moved to and fro during the rolling operation by a mechanism consisting in the rack O, attached to the carriage C, in the pinion *o'*, gearing with O, in the bevel-wheel P, fixed on the axle *i* of *o'* and gearing with the two bevel-wheels *p* and *p'*, placed loose on the vertical shaft R; moreover, in the toothed coupling-sleeve Q, sliding on a feather on the shaft R and arranged to be brought in engagement with the coupling-teeth of either of the two wheels *p* and *p'* by means of the lever *q*, and, finally, in the worm-wheel *r* on shaft R, with which gears the worm *r'* on the driving-shaft W. It will be seen herefrom that according as the sleeve Q is employed to connect the wheel *p* or the wheel *p'* with the shaft R, the carriage C, with the roll B, will be moved lengthwise along the cylinder G in one direction or the other.

For guiding the cylinder endwise the flanged rolls T are provided for, two on either side of the machine, carried by their axles *t* in arms of a slide, U, guided vertically on a hanging bracket or carriage, V, that slides on the guiding-edges *e'*. Either slide U may be moved up and down by turning the hand-wheel *f'*, and thus rotating, by means of a worm-wheel and worm, the screw *g'*, working in a nut on U. The horizontal displacement of either carriage V is obtained by a pinion, *l*, gearing in the rack *j*, fixed to V, the said pinion being connected through its shaft with a ratchet-wheel, *u*, and operated by a pawl on the lever *v*. The lever has on its end a weight by which the rolls T are continually pressed against the cylinder ends.

The cylinder to be rolled having been heated, the roll A is drawn back by means of the chain *m*, the cylinder is brought into the proper position, and the roll pushed forward again through the same until its conical end is properly in engagement with the socket S. Hereafter the carriage V on the right-hand side of the machine is moved to the left, so that the flanges of the roll T will push the cylinder against the collar *x* on the roll A. The carriage C having then been so adjusted as that the roll B will be over the left-hand end of the

cylinder, the rolls T at the other end are pressed down to create between the roll A and the cylinder the friction required to rotate the latter. Subsequently the machine is started, while the roll B and the rolls H are pressed against the cylinder, and the carriage C, with these rolls, is slowly moved to the right by an appropriate adjustment of the coupling-sleeve Q. The rolls B and H will then automatically assume an oblique position corresponding to the particular relative motion of the rolls and the cylinder, the swiveling bearings D and *h* allowing the rolls to be so displaced. The rolling operation will thus be carried out in streaks running in screw-lines around the cylinder. After the carriage C has advanced a certain distance to the right, the left-hand carriage V is pressed, with its rolls, T, against the corresponding edge of the cylinder, so as to afford additional security against any shifting of the same in this direction. Subsequently, the carriage C, on coming in contact with the right-hand carriage V, pushes it back until the roll B has arrived opposite to the right-hand edge of the cylinder. Thereupon the motion of the carriage C is reversed by shifting the coupling-sleeve Q, and in due time the right-hand rolls are again brought to bear against the cylinder. Thus the rolling operation continues until the cylinder has attained the required size, the roll B being pressed farther down after every pass from the left to the right, or vice versa.

The chief advantage which the described machine possesses over other machines serving for the same purpose, but having rolls of equal length, consists in this, that the roll A may be made of much smaller diameter without its being liable to bend, as the pressure with which the short roll B is required to act is but a fraction of the pressure necessary when both rolls are of the same length. The machine is therefore adapted for rolling cylinders or tubes of less width, and, besides, the raw cylinders to be rolled may be made with a hollow of smaller diameter.

In the process of rolling plain cylinders having equal width throughout their whole length, the box E remains stationary in respect to the carriage C—that is to say, no angular displacement of the said box takes place. If, however, the cylinders are to be wider at one end than at the other, or to have portions of conical or curved form, an automatic adjustment of the box E is required, so that the rolls B and H may always act vertically against the surface of the roll A, which in such case has of course to correspond to the form to be given to the cylinder. For this purpose the machine is provided with a mechanism consisting of an arm *u'*, fixed to one of the trunnions *e*, of the lever *v'*, pivoted at *w'* to the carriage C, and of the bars *x'* and *y'*, connecting the ends of the lever *v'*, respectively, with the arm *u'* and the top of the slide-block *z*, being on the same side of the carriage as the said trunnion *e*. Both blocks *z* are movable,

in rotative sense, on a semi-cylindrical projection, z' , of either wedge w , and the guiding-bars Y are shaped in accordance with the form of the roll A, a portion whereof is shown in Fig. 9. Thus in the said figure the bar Y is represented with the inclined part $a^2 b^2$, corresponding to the conical part $a^3 b^3$ of the roll, whereas the other parts of the bar are parallel to the cylindrical parts of the roll.

When the carriage provided with this mechanism arrives opposite to the inclined portions $a^2 b^2$ of the guiding-bars Y, the slide-blocks z will assume an oblique position, as in Fig. 9, and thus act, through the lever v' , the bars y' and x' , and the arm w' on the box E, so as to cause it to turn by the same angle as the blocks z , the two arms of the lever v' bearing to each other the proportion required for this purpose. The rolls B and H will, in consequence, also be brought into an oblique position, and thus act vertically against the conical portion $a^3 b^3$ of the roll A. In similar manner other forms deviating from the plain cylinder may be produced.

In the modified construction of machine shown by Figs. 13 to 15, the roll A is placed vertically, and the carriage C containing the rolls B and H slides on vertical guides e' , formed upon a standard, L', while it is actuated by a screw-spindle, O'. The journaled box E and mechanism for automatic angular adjustment have in this case been omitted, although they may also be employed as in the machine with horizontal rolls. The roll A is arranged to be withdrawn from the machine by means of any suitable lifting-gear. For this purpose the upper bearing, f^2 , is made conical, so that it will lift out of the frame L', together with the roll, and thus leave an opening for the roll to pass through. f' is a ring, to which the chain of the lifting-gear is to be attached. The lower journal of the roll, which is constructed as in the first-described arrangement, projects with its conical part into the hollow boss of the driving-pulley X, which rotates on a vertical pin, g' . From X motion is transmitted to the screw-spindle O' by means of the bevel-wheels n' and q' , the shaft i^2 , and the friction-disks l^2 and j^2 or k^2 , the latter two disks forming part of a sleeve, m^2 , that may be shifted on the shaft i^2 by the lever q' , so as to bring either disk j^2 or k^2 into contact with the disk l^2 and to cause rotation of the spindle O' in one direction or the other. The arrangement, as shown in the drawings, also allows the speed of rotation of O' to be varied. The pressure between the rolls A and B is obtained by means of two wedges, n^2 and o^2 , acting on the frames p^2 and q^2 , containing the bearings of the roll A, the wedges, which are connected together, being adjustable by the screw-spindle r^2 , arranged to be actuated by a hand-wheel and worm-wheel gearing. For allowing the pulley X to follow the roll A when it is shifted, the pin g^2 on which the pulley rotates is fixed to a piece, h^2 , sliding on the plate s^2 . This piece also

carries the bearings for the shaft i^2 . The cylinder to be rolled is supported by rollers T', shown in the drawings as being placed radially to a cylinder of medium diameter. The carriages V, with the flanged rolls T, are similar to those of the machine described first.

I claim as my invention—

1. In a machine for rolling seamless cylinders, the long roll A, adapted to be shifted lengthwise to the extent required for introducing the cylinder G into the machine and removing it therefrom, the short roll B, mounted by means of swiveling bearings in a carriage, C, sliding on ways e' , parallel to the roll A, and mechanisms for rotating the roll A, for shifting it lengthwise, for imparting to the carriage C a reciprocating motion, and for adjusting the rolls A and B closer together or farther apart, all combined together substantially as and for the purpose described.

2. The long roll A, carried at one end in bearings b and c , movable on ways M, parallel to the roll, the short roll B, mounted in bearings pivoted to the box E, which is adjustable toward and away from the roll A in a carriage, C, sliding on ways e' , also parallel to the roll A, and mechanisms for rotating the said roll A for shifting its bearings b and c on the ways M, for moving to and fro the carriage C on the ways e' , and for adjusting the box E in respect to the carriage C, all combined together substantially as and for the purpose described.

3. The combination, with the long roll A, short roll B, carriage C, and box E, of the guiding-rolls H, rotating in bearings h , pivoted to a frame, I, which is supported by springs and adjustable in respect to the carriage C, and means for carrying out the adjustment of I, substantially as and for the purpose described.

4. The combination, with the rolls A and B, reciprocating carriage C, and box E, of the flanged guiding-rolls T, mounted in a slide, U, adjustable on a carriage, V, movable on ways e' parallel to A, and mechanisms for adjusting U and for shifting V on the ways e' , substantially as hereinbefore set forth.

5. The combination, with a long roll, A, deviating partly or wholly from the cylindrical form, the short roll B, the box E, mounted by trunnions e in the carriage C, of the slide-blocks z , bearing on semi-cylindrical parts of the wedges w and abutting against the bars Y, having a form corresponding to the roll A, and of the arm w' , fixed to one of the trunnions e , lever v' , and connecting-bars x' and y' , substantially as and for the purpose described.

In testimony whereof I have signed my name to this specification in the presence of two subscribing witnesses.

VITAL DAELLEN.

Witnesses:

HENRY SPRINGMANN,
B. ROJ.