



(12) **EUROPEAN PATENT APPLICATION**

(43) Date of publication:  
**08.06.2022 Bulletin 2022/23**

(51) International Patent Classification (IPC):  
**H01H 25/04<sup>(2006.01)</sup> G05G 9/047<sup>(2006.01)</sup>**

(21) Application number: **20383047.6**

(52) Cooperative Patent Classification (CPC):  
**H01H 25/041; G05G 9/047; H01H 2221/012**

(22) Date of filing: **01.12.2020**

(84) Designated Contracting States:  
**AL AT BE BG CH CY CZ DE DK EE ES FI FR GB GR HR HU IE IS IT LI LT LU LV MC MK MT NL NO PL PT RO RS SE SI SK SM TR**  
 Designated Extension States:  
**BA ME**  
 Designated Validation States:  
**KH MA MD TN**

- **Rique Rebull, Adria**  
**08013 Barcelona (ES)**
- **Plaja Miró, Salvi**  
**08013 Barcelona (ES)**
- **Batiste Mayas, Clara**  
**08013 Barcelona (ES)**
- **Vázquez Villa, Francesc Xavier**  
**08013 Barcelona (ES)**

(71) Applicant: **Simon, S.A.U.**  
**08013 Barcelona (ES)**

(74) Representative: **Balder IP Law, S.L.**  
**Paseo de la Castellana 93**  
**5ª planta**  
**28046 Madrid (ES)**

(72) Inventors:  
 • **Rojas Adamez, Jesús Baldemar**  
**08013 Barcelona (ES)**

(54) **MULTI-SWITCH**

(57) Multi-switch (D), comprising a base (B) and a key (T) articulated at two ends with respect to the base (B) such that the key (T) can be in a resting position, rotate about a first axis ( $\Gamma1$ ) or about a second axis ( $\Gamma2$ ) or be displaced in a z direction (Z) and that comprises a first end micro switch (MS1) and a central micro switch (MSC) wherein the activation angle ( $\alpha1-act$ ) of the first end micro-switch (MS1) is greater than the first activation angle ( $\alpha1C-act$ ) of the central micro-switch (MSC), such that at least three intervals are defined depending on the rotation angle of the key (T) about the first axis ( $\Gamma1$ ), an interval wherein none of the first end (MS1) and central (MSC) micro-switches are activated, an interval wherein only the central micro-switch (MSC) is activated and an interval wherein both the first end (MS1) and central (MSC) micro-switches are activated.

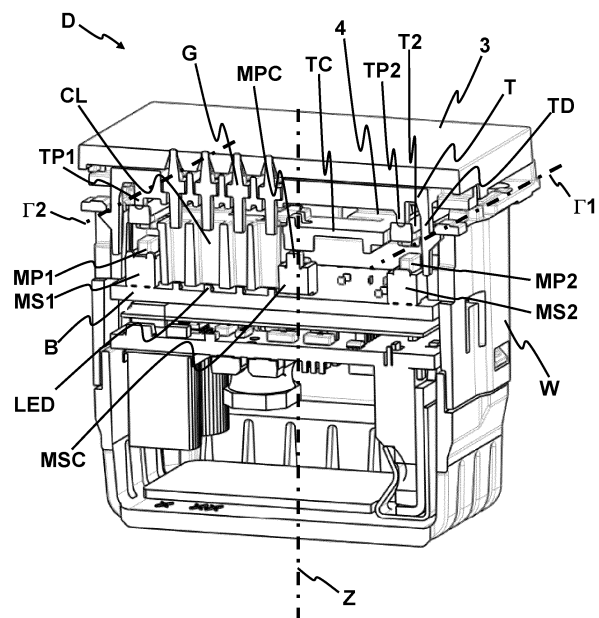

Fig. 3

**Description****TECHNICAL FIELD**

[0001] The present invention relates to a multi-switch, in particular to a multi-switch that comprises at least three microswitches.

**STATE OF THE ART**

[0002] Multi-switches are known designed to control the on/ off of an electric load as well as its intensity level.

[0003] In this type of device, the highest reliability and ergonomics are sought, that is, that the device does what the user wants in the most comfortable way for him.

[0004] One way to implement a multi-switch is by using microswitches, which are miniaturized, very short-stroke switches. These microswitches are activated by a larger key, intended to be pressed by the user, which is provided with suitable extensions to press the micro-switches, with the possible interposition of intermediate effort transmission tabs. These tabs, apart from transmitting forces, also act as an element for urging the key towards a rest position.

[0005] An advantage of this arrangement is that with minimum pressure strokes it is possible to activate the micro-switches, since these are distances of the order of one millimetre. For this reason, they are very ergonomic solutions, since the user only has to exert light pressure on the key.

[0006] These solutions usually use one key per switch, so there is no uncertainty for the user. However, it tends to simplify its design by making one key can activate two switches.

[0007] Known devices based on this solution, however, have the drawback that some areas of the key present uncertainty with respect to the microswitch that they will activate.

[0008] Therefore, a solution is needed that allows implementing a multi-switch with a single key that activates two or more microswitches and that there is the minimum uncertainty for the user, that is to say that those areas in which the device does not responds appropriately to the pressure of the user, or in other words, that there is a great correspondence between the zone that is pressed and the functions that are activated, either on or off, or increasing or reducing intensity.

**DESCRIPTION OF THE INVENTION**

[0009] For overcoming the mentioned drawbacks and achieve the aforementioned aim, the invention proposes a multi-switch, comprising a base and a key articulated at two ends with respect to the base by means of a first axis and a second axis parallel to the first axis, each axis comprising an unidirectional connection such that the key can:

- be in a resting position in which the key abuts on the unidirectional connection of each axis;
- rotate about the first axis when a first zone of the key proximate to the second axis is pressed, such that the key loses contact with the second axis;
- rotate about the second axis when a second zone of the key proximate to the first axis is pressed, such that the key loses contact with the first axis;
- be displaced in a Z-direction perpendicular to the plane which contains the first and second axes when a central zone located between the first and second zones is pressed;
- a first end micro switch located on the base beneath the first zone and comprising an actuation point, the key comprising a first end point for directly or indirectly pressing the actuation point of the first micro-switch;
- a central micro switch located on the base beneath the central zone and comprising an actuation point, the key comprising a central end point for directly or indirectly pressing the actuation point of the central micro-switch;

such that the following rotation angles for the key can be defined with respect to the resting position:

- a activation angle  $\alpha 1-act$  of the first end micro-switch when the key rotates about the first axis corresponding to the first end point activating the actuation point of the first end micro-switch;
- a central activation angle  $\alpha 1C-act$  of the central micro-switch when the key rotates about the first axis corresponding to the central end point activating the actuation point of the central micro-switch;

wherein the activation angle  $\alpha 1-act$  of the first end micro-switch is greater than the first activation angle  $\alpha 1C-act$  of the central micro-switch:

$$\alpha 1C-act < \alpha 1-act \quad (I)$$

such that at least three intervals are defined depending on the rotation angle of the key about the first axis :

- an interval wherein none of the first end and central micro-switches are activated;
- an interval wherein only the central micro-switch is activated;
- an interval wherein both the first end and central micro-switches are activated.

[0010] By unidirectional connection it is understood in the context of the present invention a mechanical interaction of a positive type, that is to say abutting surface with another surface, so that they can only exert mutual forces when abutting on each other, and therefore when some part of the unidirectional contact is requested in

the direction contrary to the support, they separate. This is the type of mechanical link present in floating type buttons.

**[0011]** With respect to the micro-switches, they are understood as consisting of a fixed part, in this case fixed to the base, and an activation button, which we call the actuation point, as it is a very small button.

**[0012]** Therefore, with the characteristics of the invention, a device consisting essentially of a single key and two microswitches can be precisely controlled. Furthermore, by programming the underlying electronics, it is possible by means of the invention to establish combinations of activation and deactivation of the microswitches that are univocal, that is, to establish a univocal relationship between the key areas that are pressed and the function that the multi-switch dimmer will execute.

**[0013]** In some embodiments, the multi-switch comprises a second end micro switch located on the base beneath the second zone, and this second end micro switch comprises an actuation point, the key comprising a second end point for directly or indirectly pressing the actuation point of the second end micro switch, such that the following rotation angles may be defined:

- a activation angle  $\alpha_{2-act}$  of the second end micro-switch when the key rotates about the second axis corresponding to the contact between the second end point and the actuation point of the second end micro-switch;
- a second activation angle  $\alpha_{2C-act}$  of the central micro-switch when the key rotates about the second axis corresponding to the contact between the central end point and the actuation point of the central micro-switch; wherein the activation angle  $\alpha_{2-act}$  of the second end micro-switch is greater than the second activation angle  $\alpha_{2C-act}$  of the central micro-switch:

$$\alpha_{2C-act} < \alpha_{2-act} \quad (III)$$

such that at least three intervals are defined depending on the rotation angle of the key about the second axis:

- an interval wherein none of the second end and central micro-switches are activated;
- an interval wherein only the central micro-switch is activated;
- an interval wherein both the second end and central micro-switches are activated.

**[0014]** Therefore, it is possible to extend the invention to a key comprising three microswitches, and it is possible to precisely control more functions.

**[0015]** In some embodiments, the unidirectional connections are formed by downwards extensions of the key provided with retaining projections, the dimmer compris-

ing walls solidary to the base provided with retaining steps for the retaining projections.

**[0016]** In some embodiments, the multi-switch comprises one or more mechanical stops configured to limit the rotation angle of the key and/or to limit the downward displacement of the key.

**[0017]** These stops are designed so that the microswitches never operate in overpressure conditions and thus extend their useful life.

**[0018]** In some embodiments, the multi-switch further comprises a light intensity indicator, in turn formed by light sources placed in the base and light guides embedded in the key, with optionally the presence of light channels.

**[0019]** The first and central micro-switches can be activated by flexible tabs directly or indirectly connected to the key, such that once the central micro-switch is activated, by continuing pressing the key, the flexible tab associated to the central micro-switch starts to flex towards the key.

**[0020]** The afore-mentioned mechanical stops shall be dimensioned to guarantee that the flexible tabs remain in their elastic work range (letting outside the zones where they deform plastically with remaining deformation and obviously far from the rupture point).

**[0021]** The switch can be provided with elastic elements aimed at press the key upwards, to maintain it in the rest position. For this purpose, tabs can be used, directly joined to the key itself, or joined to a fixed element as disclosed below.

**[0022]** In some embodiments the multi-switch comprises an intermediate plate, placed between key and the base, the intermediate plate comprising flexible tabs such that the flexible tabs transmit the pressure from the end points to the actuation points. These tabs also act as an element for urging the key towards a rest position.

**[0023]** Preferably, in this case, the tabs could be dimensioned and arranged so that they can perform a protection function for the microswitches, that is, to elastically deform when they fully press the microswitch.

**[0024]** This feature makes it possible to economically and reliably have the means for biasing the key towards its rest position. On the other hand, it offers flexibility to the possible positions of the microswitches.

**[0025]** In some embodiments the multi-switch comprises a cover configured to be directly pressed by a user and attached to the key, the cover preferably comprising through holes for fitting light guides.

**[0026]** By segregating the aesthetic and touch functions in a separate piece, it is possible to optimize the materials of each of the parts.

**[0027]** In some embodiments, the key comprises a plurality of reinforcement ribs. By providing rigidity to the key, the predictability of the multi-switch behavior is improved. As specified above, if a softer touch is desired, suitable materials can be chosen for the outer cover, but always ensuring sufficient rigidity of the key, so that the claimed angle ranges are respected.

**[0028]** In the multi-switch of the invention, the following distances may be defined:

- an endstop length which is the distance between the first axis and the end of the key at the first zone;
- an endstop height which is the maximum displacement of the key with respect to the base at the end of the key at the first zone,

wherein a ratio endstop length/endstop height is greater than 1, preferably comprised in the range between 10 and 27.

**[0029]** Preferably, the ratio endstop length/endstop height is 20 and/or the endstop height is comprised between 1.2 and 4 mm.

**[0030]** In the multi-switch dimmer of the invention, the following distances may be defined:

- a central micro-switch displacement which is a maximum displacement of the key at the end point of the central zone when the key is rotated about the first axis, and
- a first end micro-switch displacement which is a maximum displacement of the key at the first end point of the first zone when the key is rotated about the first axis.

**[0031]** Preferably, the central micro-switch displacement is comprised between 0.3 and 1 mm and the first end micro-switch displacement is between 1.1 and 2 mm.

**[0032]** Also on a preferred embodiment, the endstop height is comprised between 2.1 and 2.3 mm.

**[0033]** Preferably, the multi-switch comprises a lower plate provided with electronic components and a lower cover.

**[0034]** Finally, in some embodiments the multi-switch is a dimmer.

#### BRIEF DESCRIPTION OF THE DRAWINGS

**[0035]** To complete the description and in order to provide a better understanding of the invention, a set of drawings is provided. Said drawings form an integral part of the description and illustrate embodiments of the invention, which should not be interpreted as restricting the scope of the invention, but just as an example of how the invention can be carried out. The drawings comprise the following figures:

Fig. 1 shows a schematic illustration of the three zones in a multi-switch according to an embodiment of the invention.

Fig. 2 shows a schematic illustration of the positions of the three micro-switches in the multi-switch.

Fig. 3 and 4 show a perspective of a longitudinal cross section through the multi-switch spanning the

three zones and showing the key, internal components and the base of the multi-switch.

Fig. 5 shows the same cross section as fig. 4 during compression of the key at an end thereof.

Fig. 6 shows the same cross section as fig. 4 during further compression of the key.

Fig. 7 shows a transversal cross section of the multi-switch, in a direction perpendicular to the longitudinal cross section of figures 3 - 6.

Fig. 8 shows a full view of the multi-switch.

Fig. 9 shows a schematic representation of various multi-switch parameters.

Fig. 10 shows a plan view of the intermediate plate provided with elastic tabs, isolated from the other components.

Fig. 11 shows a perspective view of a key comprising reinforcement ribs and micro-switch activators.

Fig. 12 shows an exploded view of the multi-switch according to the invention.

#### DESCRIPTION OF A WAY OF CARRYING OUT THE INVENTION

**[0036]** As shown in Fig. 1, the multi switch D comprises a key with three zones: A1 and A2 at two opposite ends and AC in the centre. The user-facing surface of the multi-switch should provide sensory indication differentiating the three zones. Preferably, the surface could comprise a difference in tactile quality between adjacent zones, although they may also be visually marked out. The multi-switch is configured to allow a user to control one or more electric loads by compressing a key T in one of the three zones.

**[0037]** Each zone is associated with an underlying microswitch respectively, MS1, MS2 and MSC

**[0038]** To this end, and as shown in Fig 3, the multi-switch D comprises a base B and a key T articulated at two ends with respect to the base B by means of a first axis  $\Gamma 1$  and a second axis  $\Gamma 2$  parallel to the first axis  $\Gamma 1$ .

**[0039]** By articulated with it should be understood that if the base B is considered as an absolute reference, the key T can perform a rotational movement with respect to it. That is, physically, the key is not articulated with the base B, but rather it is articulated with respect to walls W that are solidary with the base B. Said in other words, the walls and the base have a fixed relative position, they can be either made of separate parts that are joined, or they could even form part of a single molded part. In general, these walls W form the outer envelope of the switch.

**[0040]** As mentioned above, the invention deals with a key that could be considered as floating, and guided by some flexible elements, such as springs or flexible tabs, and some retaining projections, to avoid its range of lateral and vertical movements, which are of interest to us for the purposes of the selective actuation that is the subject of this context.

**[0041]** To this end, and as shown in figure 3, each axis  $\Gamma 1$ ;  $\Gamma 2$  comprises an unidirectional (this concept is well known in mechanics and has been explained above) connection 12, 14, 16, 18, such that the key T can:

- be in a resting position in which the key T abuts on the unidirectional connection 12, 14, 16, 18 of each axis  $\Gamma 1$ ;  $\Gamma 2$ ;
- rotate about the first axis  $\Gamma 1$  when a first zone A1 of the key T proximate to the second axis  $\Gamma 2$  is pressed, such that the key T loses contact with the second axis  $\Gamma 2$ ;
- rotate about the second axis  $\Gamma 2$  when a second zone A2 of the key T proximate to the first axis  $\Gamma 1$  is pressed, such that the key T loses contact with the first axis  $\Gamma 1$ ;
- be displaced in a z direction Z perpendicular to the plane which contains the first  $\Gamma 1$  and second  $\Gamma 2$  axes when a central zone AC located between the first A1 and second zones A2 is pressed.

The multi-switch also comprises a:

- a first end micro-switch MS1 located on the base B beneath the first zone A1 and comprising an actuation point MP1, the key T comprising a first end point TP1 for directly or indirectly pressing the actuation point MP1 of the first micro-switch MS1;
- a central micro switch MSC located on the base B beneath the central zone AC and comprising an actuation point MPC, the key T comprising a central end point TPC for directly or indirectly pressing the actuation point MPC of the central micro-switch MSC. Thus defined, the following rotation angles for the key T can be defined with respect to the resting position:
  - a activation angle  $\alpha 1-act$  of the first end micro-switch MS1 when the key T rotates about the first axis  $\Gamma 1$  corresponding to the first end point TP1 activating the actuation point MP1 of the first end micro-switch MS1;
  - a first activation angle  $\alpha 1C-act$  of the central micro-switch MSC when the key T rotates about the first axis  $\Gamma 1$  corresponding to the central end point TPC activating the actuation point MPC of the central micro-switch MSC.

**[0042]** What stands out in the present invention, is that the activation angle  $\alpha 1-act$  of the first end micro-switch MS1 is greater than the first activation angle  $\alpha 1C-act$  of the central micro-switch MSC:

$$\alpha 1C-act < \alpha 1-act \quad I$$

**[0043]** If this condition is met, then three intervals are defined depending on the rotation angle of the key T about the first axis  $\Gamma 1$ :

- an interval wherein none of the first end MS1 and central MSC micro-switches are activated;
- an interval wherein only the central micro-switch MSC is activated;
- an interval wherein both the first end MS1 and central MSC micro-switches are activated.

**[0044]** Therefore, an unambiguous relationship is established between the angle of rotation of the K key and the switch-on combinations of the microswitches, whose combinations of on/ off states can be associated with different actions, such as preferably intensity control of a light source.

**[0045]** The invention can be extended by including a second end micro switch MS2 located on the base B beneath the second zone A2 and comprising an actuation point MP2 as well.

**[0046]** Then, in analogous manner as for the first end microswitch, the key T comprises a second end point TP2 for directly or indirectly pressing the actuation point MP2 of the second end micro-switch MS2.

**[0047]** Again, the following rotation angles may be defined:

- an activation angle  $\alpha 2-act$  of the second end micro-switch MS2 when the key T rotates about the second axis  $\Gamma 2$  corresponding to the contact between the second end point TP2 and the actuation point MP2 of the second end micro-switch MS2;
- a second activation angle  $\alpha 2C-act$  of the central micro-switch MSC when the key T rotates about the second axis  $\Gamma 2$  corresponding to the contact between the central end point TPC and the actuation point MPC of the central micro-switch MSC; wherein the activation angle  $\alpha 2-act$  of the second end micro-switch MS2 is greater than the second activation angle  $\alpha 2C-act$  of the central micro-switch MSC:

$$\alpha 2C-act < \alpha 2-act \quad III$$

**[0048]** Therefore, again at least three intervals are defined depending on the rotation angle of the key T about the second axis  $\Gamma 2$ :

- an interval wherein none of the second end MS2 and central MSC micro-switches are activated;
- an interval wherein only the central micro-switch MSC is activated;
- an interval wherein both the second end MS2 and central MSC micro-switches are activated.

**[0049]** There are plenty of ways to implement the unidirectional connections, but an unidirectional connection formed by downwards extensions TD of the key T provided with retaining projections 14, 16 that cooperate with retaining steps 12, 18 for the retaining projections 14, 16 is preferred. Said otherwise, the links are in the form of legs at two parallel edges of the key. The legs limit the outward displacement of the key but allow each or both edges of the key to be pressed towards the base B. The key T is by default urged away from the base B such that in the resting position, the interacting legs are in contact with one another.

**[0050]** These retaining projections 14, 16 are materialized in walls W solidary to the base B.

**[0051]** For protecting the micro-switches, the multi-switch D comprises, as shown in figure 7, one or more mechanical stops 20, 22, 24, 26, 30, 32, 34, 36, 38 configured to limit the rotation angle of the key T and/or to limit the downward displacement Z of the key T.

**[0052]** An advantageous aspect of the multi-switch, as labelled for example in figure 3, is that it further comprises an intensity indicator, in turn formed by light sources LED placed in the base B and light guides G embedded in the key T, with optionally the presence of light channels CL. The multi-switch also comprises a cover 3 configured to be directly pressed by a user and attached to the key T, the cover 3 preferably comprising through holes 31 for fitting the light guides G.

**[0053]** As also shown in fig. 3, the multi-switch D comprises an intermediate plate 4, placed between key T and the base B, the intermediate plate 4 comprising flexible tabs T1, T2, TC, such that the flexible tabs T1, T2, TC transmit the pressure from the end points TP1, TP2, TPC to the actuation points MP1, MP2, MPC. The flexible tabs T1, T2, TC also act as an element for urging the key towards a rest position.

**[0054]** One important aspect of the multi-switch from the mechanical point of view is that the key T comprises a plurality of reinforcement ribs TR that provides stiffness thereto, and therefore an accurate control of the micro-switches.

**[0055]** Now regarding the absolute dimensions, it is useful to define the following distances:

- an endstop length  $L_{endstop}$  which is the distance between the first axis  $\Gamma 1$  and the end of the key T at the first zone A1;
- an endstop height  $H_{endstop}$  which is the maximum displacement of the key T with respect to the base B at the end of the key T at the first zone A1.

**[0056]** In this regard, the inventors have found that a ratio endstop length / endstop height  $L_{endstop} / H_{endstop}$  comprised in the range [10; 27] provides for good dynamic results and that preferably the ratio endstop length / endstop height  $L_{endstop} / H_{endstop}$  is 20 and/or the endstop height  $H_{endstop}$  is comprised between 1.2 and 4 mm.

**[0057]** Also the following parameters can be defined:

- a central micro-switch displacement  $H_{on/off}$  which is a maximum displacement of the key T at the end point TPC of the central zone AC when the key T is rotated about the first axis  $\Gamma 1$ , and
- a first end micro-switch displacement  $H_{switch}$  which is a maximum displacement of the key T at the first end point TP1 of the first zone A1 when the key T is rotated about the first axis  $\Gamma 1$ .

**[0058]** For these parameters, the following values are preferred:

- The central micro-switch displacement  $H_{on/off}$  is between 0.3 and 1.1 mm and t
- The first end micro-switch displacement  $H_{switch}$  is between 1.1 and 2 mm.

In a preferred embodiment the endstop height  $H_{endstop}$  is between 2.1 and 2.3 mm.

**[0059]** Finally, the multi-switch comprises a lower plate 5 provided with electronic components and a lower cover 6.

**[0060]** Fig. 4 shows a longitudinal cross-section of the multi-switch D in a resting position. In this figure, it can be observed that the pairs of legs 12, 14 and 16, 18 will lose contact with one another if the key is moved downwards (without rotation). By pressing the key in the central zone AC the key is displaced downwards in the z direction Z defined before, then the central end point TPC begins to displace the central tab TC and hence this press the actuation point MPC of the central micro-switch MSC. The effect of this is that an electric load or more is switched on or off.

In a preferred embodiment, the multi-switch is a dimmer for controlling light sources, so the effect of the activation of the central micro-switch is that a light is switched on or off.

**[0061]** Fig. 5 shows a longitudinal cross-section of the dimmer D when a user presses the key T downwards in the left area causing the key T to tilt around the first axis. The first axis is formed by the pair of legs 16, 18. In this figure, the key has practically reached the first activation angle  $\alpha 1C-act$  of the central micro-switch MSC but has not reached the activation angle  $\alpha 1-act$  of the first micro-switch MS1. In the embodiment in which the multi-switch is a dimmer, by pressing the first zone but not enough for reaching the activation angle  $\alpha 1-act$  of the first micro-switch MS1, the central micro-switch is activated, and therefore the light is switched on or off as when the central zone is pressed.

**[0062]** Fig. 6 shows a longitudinal cross-section of the multi-switch D when a user continues to press the key T downwards in the left zone. Eventually, the tilt angle of the key T reaches the activation angle  $\alpha 1-act$  of the first micro-switch MS1. In the embodiment in which the multi-switch is a dimmer the activation of the first micro-switch

MS1 changes the intensity of the light, which for instance may be increased.

**[0063]** In this text, the term "comprises" and its derivations (such as "comprising", etc.) should not be understood in an excluding sense, that is, these terms should not be interpreted as excluding the possibility that what is described and defined may include further elements.

**[0064]** The invention is obviously not limited to the specific embodiments described herein, but also encompasses any variations that may be considered by any person skilled in the art within the general scope of the invention as defined in the claims.

## Claims

1. Multi-switch (D), comprising a base (B) and a key (T) articulated at two ends with respect to the base (B) by means of a first axis ( $\Gamma 1$ ) and a second axis ( $\Gamma 2$ ) parallel to the first axis ( $\Gamma 1$ ), each axis ( $\Gamma 1$ ;  $\Gamma 2$ ) comprising an unidirectional connection (12, 14, 16, 18), such that the key (T) can:

- be in a resting position in which the key (T) abuts on the unidirectional connection (12, 14, 16, 18) of each axis ( $\Gamma 1$ ;  $\Gamma 2$ );
- rotate about the first axis ( $\Gamma 1$ ) when a first zone (A1) of the key (T) proximate to the second axis ( $\Gamma 2$ ) is pressed, such that the key (T) loses contact with the second axis ( $\Gamma 2$ );
- rotate about the second axis ( $\Gamma 2$ ) when a second zone (A2) of the key (T) proximate to the first axis ( $\Gamma 1$ ) is pressed, such that the key (T) loses contact with the first axis ( $\Gamma 1$ );
- be displaced in a z direction (Z) perpendicular to the plane which contains the first ( $\Gamma 1$ ) and second ( $\Gamma 2$ ) axes when a central zone (AC) located between the first (A1) and second zones (A2) is pressed,

**characterized in that** it comprises:

- a first end micro switch (MS1) located on the base (B) beneath the first zone (A1) and comprising an actuation point (MP1), the key (T) comprising a first end point (TP1) for directly or indirectly pressing the actuation point (MP1) of the first end micro switch (MS1);
- a central micro switch (MSC) located on the base (B) beneath the central zone (AC) and comprising an actuation point (MPC), the key (T) comprising a central end point (TPC) for directly or indirectly pressing the actuation point (MPC) of the central micro switch (MSC);

such that the following rotation angles for the key (T) can be defined with respect to the resting position:

- an activation angle ( $\alpha 1-act$ ) of the first end micro-switch (MS1) when the key (T) rotates about the first axis ( $\Gamma 1$ ) corresponding to the first end point (TP1) activating the actuation point (MP1) of the first end micro-switch (MS1);
- a first activation angle ( $\alpha 1C-act$ ) of the central micro-switch (MSC) when the key (T) rotates about the first axis ( $\Gamma 1$ ) corresponding to the central end point (TPC) activating the actuation point (MPC) of the central micro-switch (MSC);

wherein the activation angle ( $\alpha 1-act$ ) of the first end micro-switch (MS1) is greater than the first activation angle ( $\alpha 1C-act$ ) of the central micro-switch (MSC):

$$\alpha 1C-act < \alpha 1-act \quad (I)$$

such that at least three intervals are defined depending on the rotation angle of the key (T) about the first axis ( $\Gamma 1$ ):

- an interval wherein none of the first end (MS1) and central (MSC) micro-switches are activated;
- an interval wherein only the central micro-switch (MSC) is activated;
- an interval wherein both the first end (MS1) and central (MSC) micro-switches are activated.

2. Multi-switch (D) according to any of the previous claims, comprising a second end micro-switch (MS2) located on the base (B) beneath the second zone (A2) and comprising an actuation point (MP2), the key (T) comprising a second end point (TP2) for directly or indirectly pressing the actuation point (MP2) of the second end micro-switch (MS2), such that the following rotation angles may be defined:

- an activation angle ( $\alpha 2-act$ ) of the second end micro-switch (MS2) when the key (T) rotates about the second axis ( $\Gamma 2$ ) corresponding to the contact between the second end point (TP2) and the actuation point (MP2) of the second end micro-switch (MS2);
- a second activation angle ( $\alpha 2C-act$ ) of the central micro-switch (MSC) when the key (T) rotates about the second axis ( $\Gamma 2$ ) corresponding to the contact between the central end point (TPC) and the actuation point (MPC) of the central micro-switch (MSC); wherein the activation angle ( $\alpha 2-act$ ) of the second end micro-switch (MS2) is greater than the second activation angle ( $\alpha 2C-act$ ) of the central micro-switch (MSC):

$$\alpha 2C-act < \alpha 2-act \quad (III)$$

such that at least three intervals are defined de-

- pending on the rotation angle of the key (T) about the second axis ( $\Gamma 2$ ):
- an interval wherein none of the second end (MS2) and central (MSC) micro-switches are activated; 5
  - an interval wherein only the central micro-switch (MSC) is activated;
  - an interval wherein both the second end (MS2) and central (MSC) micro-switches are activated. 10
3. Multi-switch (D) according any of the previous claims, wherein the unidirectional connections are formed by downwards extensions (TD) of the key (T) provided with retaining projections (14, 16), the multi-switch comprising walls (W) solidary to the base (B) provided with retaining steps (12, 18) for the retaining projections (14, 16). 15
  4. Multi-switch (D) according to any of the previous claims, comprising one or more mechanical stops (20, 22, 24, 26, 30, 32, 34, 36, 38) configured to limit the rotation angle of the key (T) and/or to limit the downward displacement (Z) of the key (T). 20 25
  5. Multi-switch (D) according to any of the previous claims, wherein the multi-switch further comprises a light intensity indicator, in turn formed by light sources (LED) placed in the base (B) and light guides (G) embedded in the key (T), with optionally the presence of light channels (CL). 30
  6. Multi-switch (D) according to any of the previous claims, which comprises an intermediate plate (4), placed between key (T) and the base (B), the intermediate plate (4) comprising flexible tabs (T1, T2, TC), such that the flexible tabs (T1, T2, TC) transmit the pressure from the end points (TP1, TP2, TPC) to the actuation points (MP1, MP2, MPC). 35 40
  7. Multi-switch (D) according to any of the previous claims, further comprising a cover (3) configured to be directly pressed by a user and attached to the key (T), the cover (3) preferably comprising through holes (31) for fitting light guides (G). 45
  8. Multi-switch (D) according to any of the previous claims, wherein the key (T) comprises a plurality of reinforcement ribs (TR). 50
  9. Multi-switch (D) according to any of the previous claims wherein the following distances may be defined: 55
    - an endstop length ( $L_{endstop}$ ) which is the distance between the first axis ( $\Gamma 1$ ) and the end of the key (T) at the first zone (A1);
- an endstop height ( $H_{endstop}$ ) which is the maximum displacement of the key (T) with respect to the base (B) at the end of the key (T) at the first zone (A1),
- wherein a ratio  $L_{endstop}/H_{endstop}$  is comprised in the range [10; 27].
10. Multi-switch (D) according to claim 7 wherein the ratio  $L_{endstop}/H_{endstop}$  is 20 and/or the endstop height ( $H_{endstop}$ ) is comprised between 1.2 and 4 mm.
  11. Multi-switch (D) according to any of claims 7 to 9 wherein the following distances may be defined:
    - a central micro-switch displacement ( $H_{on/off}$ ) which is a maximum displacement of the key (T) at the end point (TPC) of the central zone (AC) when the key (T) is rotated about the first axis ( $\Gamma 1$ ), and
    - a first end micro-switch displacement ( $H_{switch}$ ) which is a maximum displacement of the key (T) at the first end point (TPC) of the first zone (AC) when the key (T) is rotated about the first axis ( $\Gamma 1$ ),
 wherein central micro-switch displacement ( $H_{on/off}$ ) is between 0.34 and 1.04 mm and the first end micro-switch displacement ( $H_{switch}$ ) is between 1.17 and 1.91 mm.
  12. Multi-switch (D) according to claim 10 wherein the endstop height ( $H_{endstop}$ ) is between 2.13 and 2.27 mm.
  13. Multi-switch (D) according to any of the previous claims, comprising a lower plate (5) provided with electronic components and a lower cover (6).

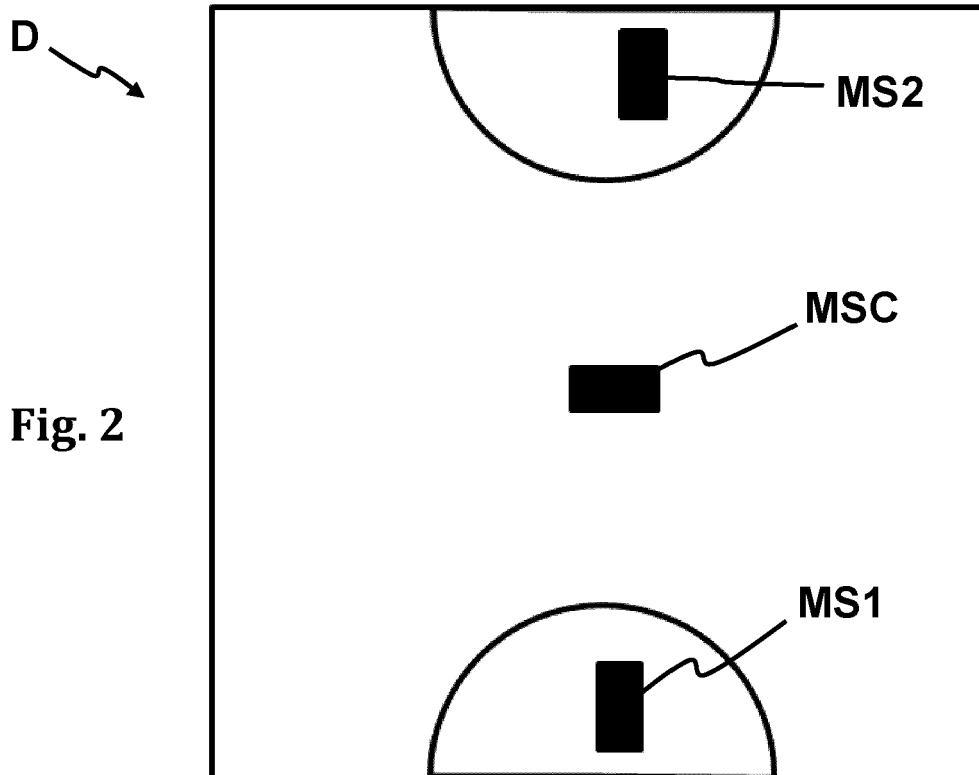
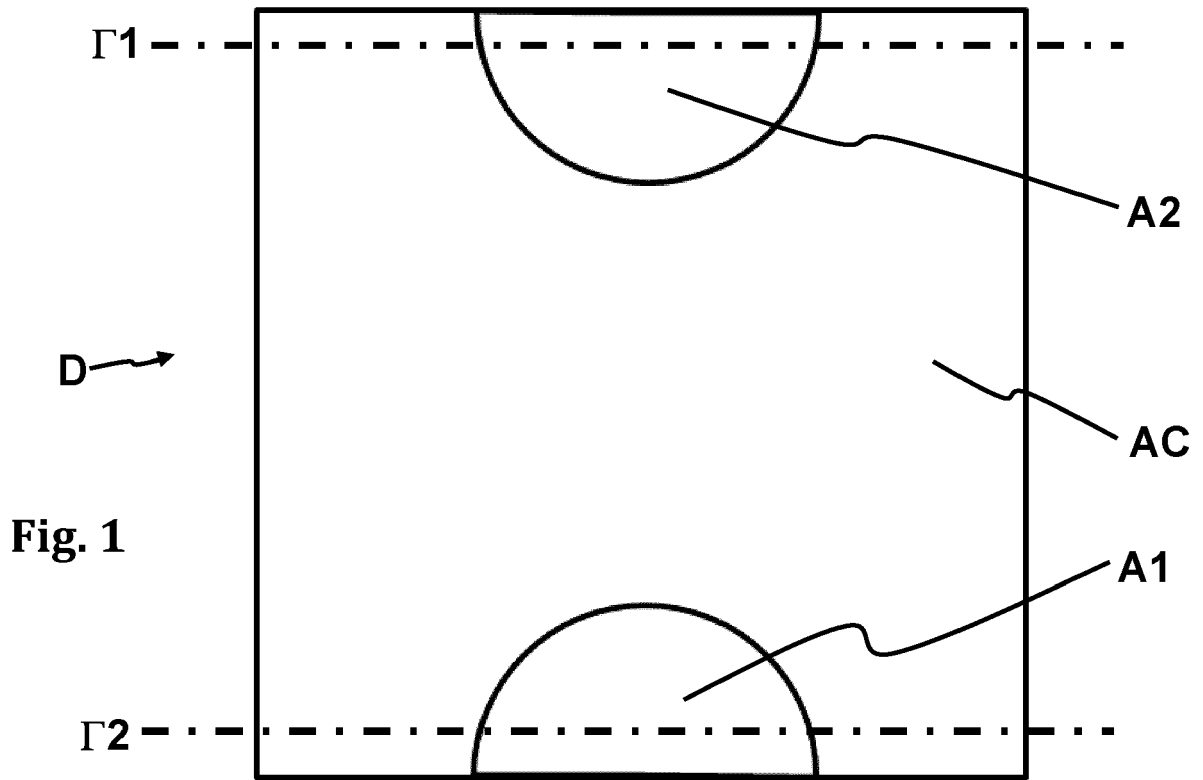

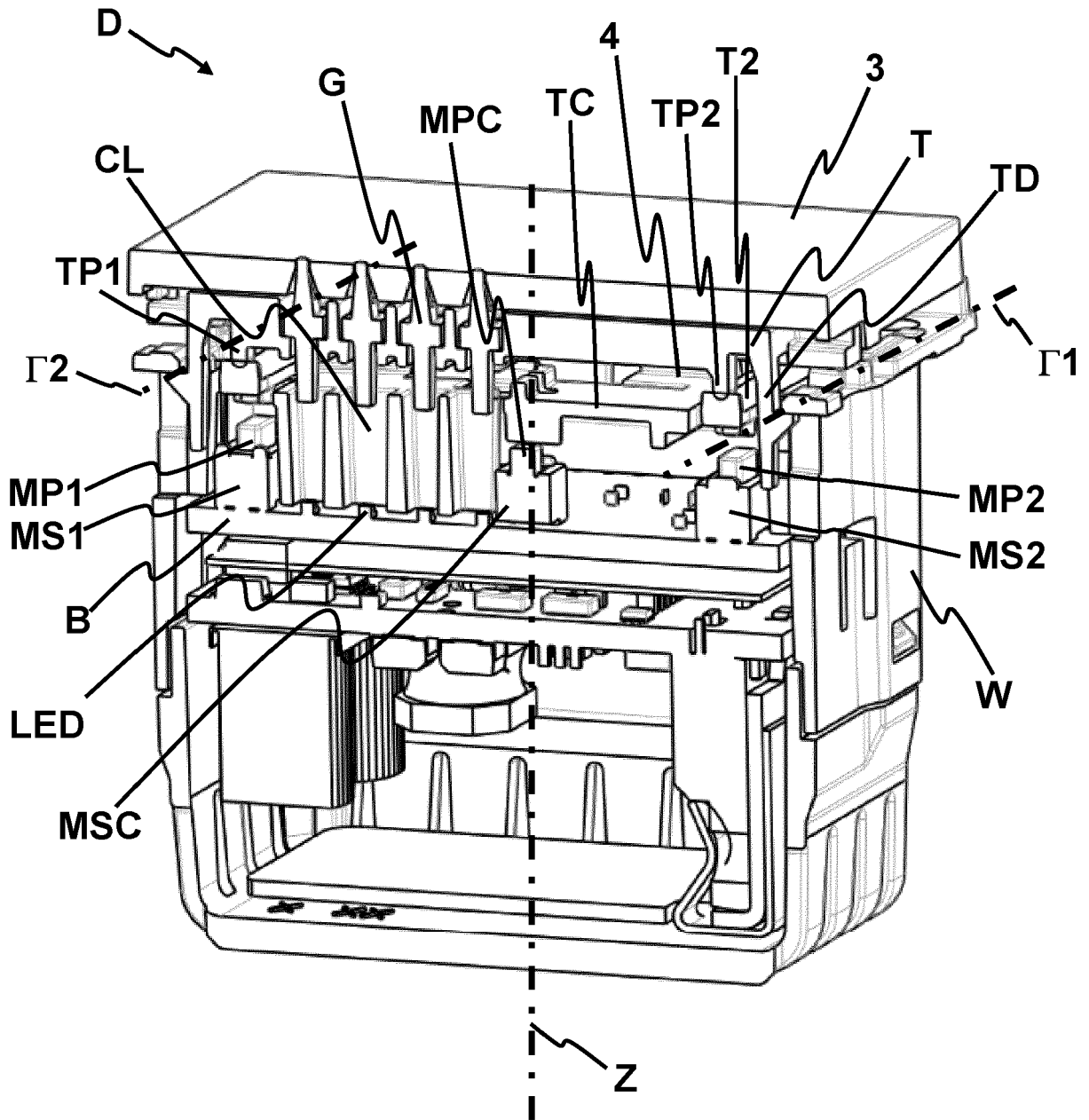

Fig. 3

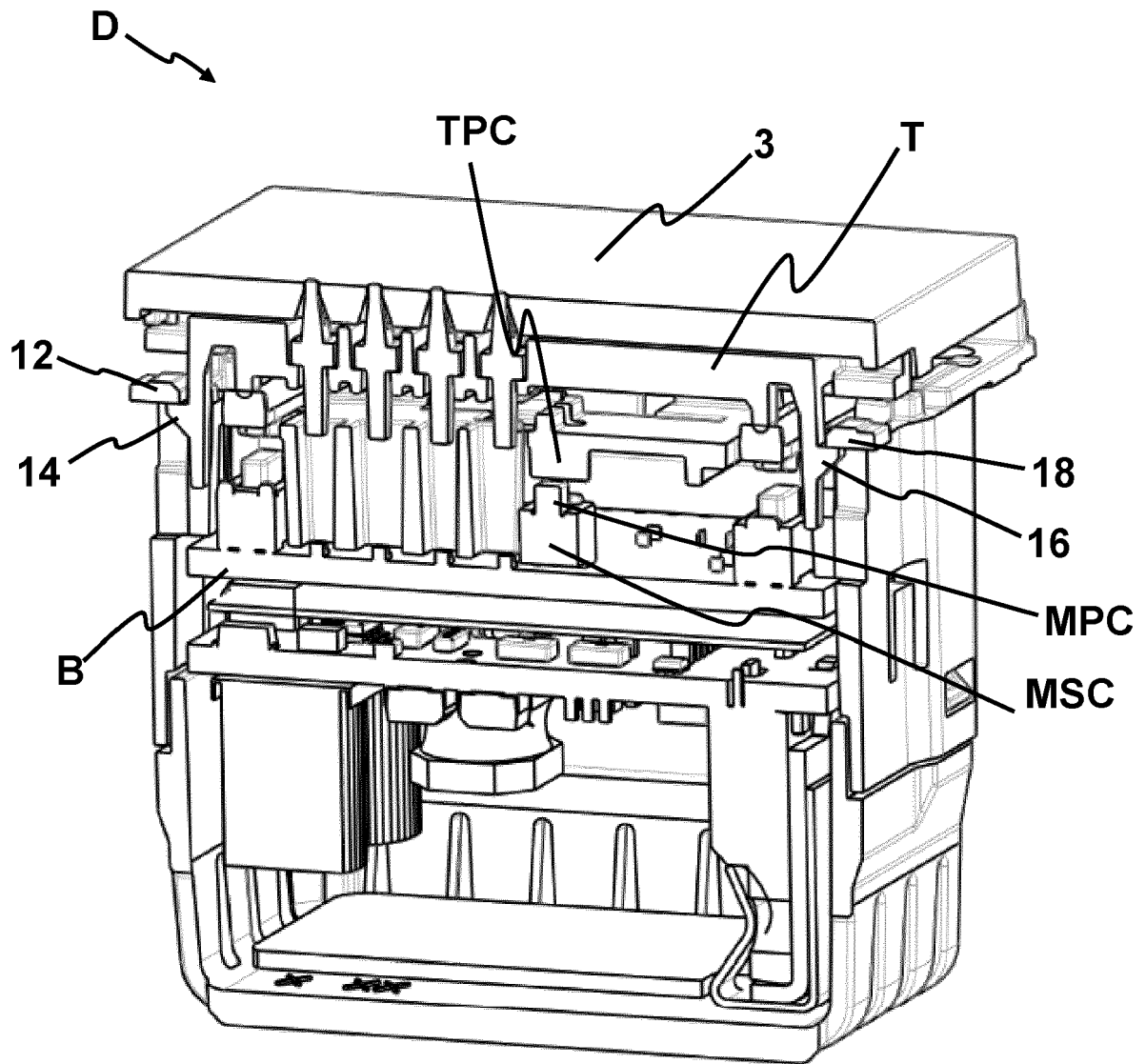

Fig. 4

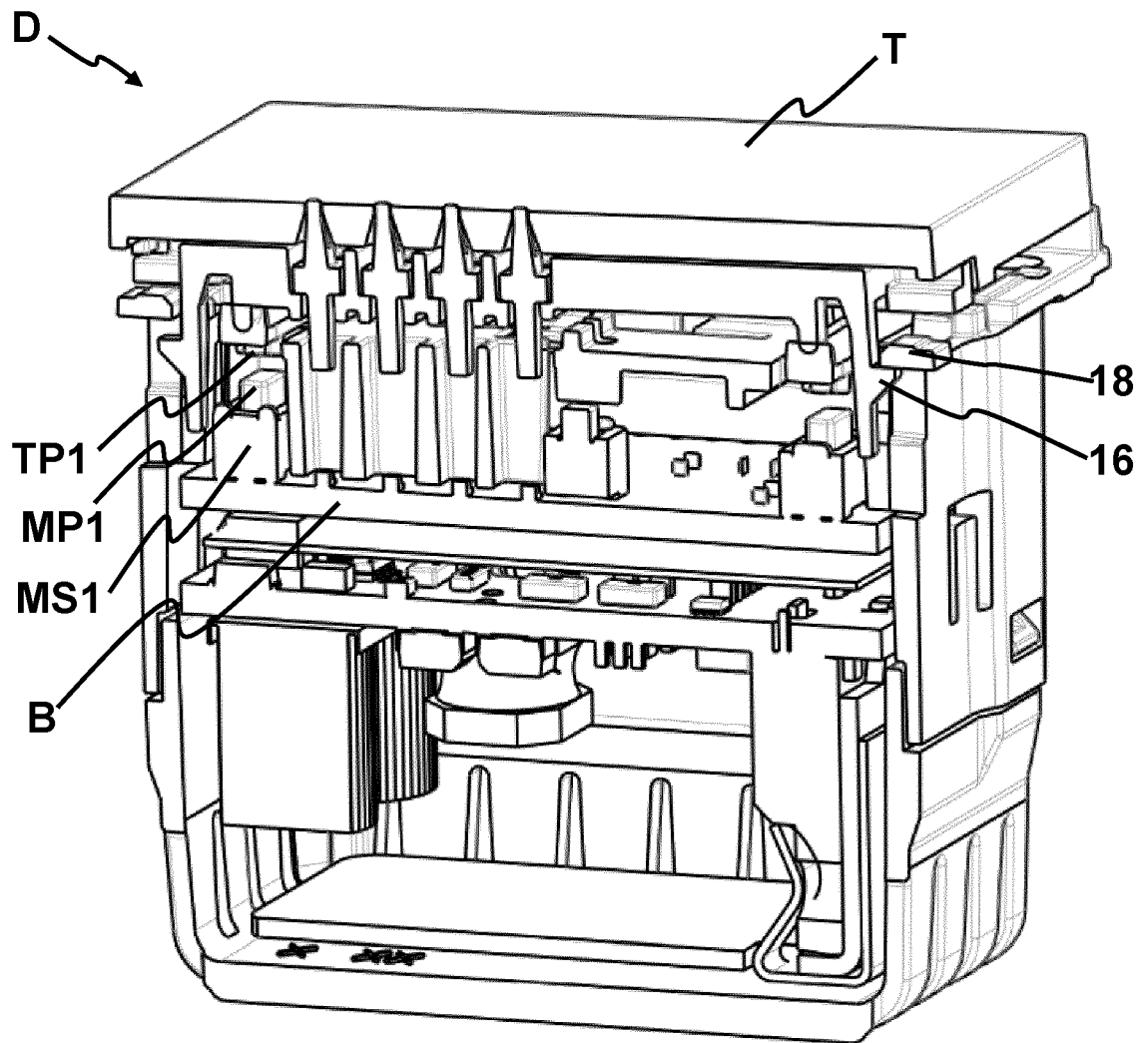

Fig. 5

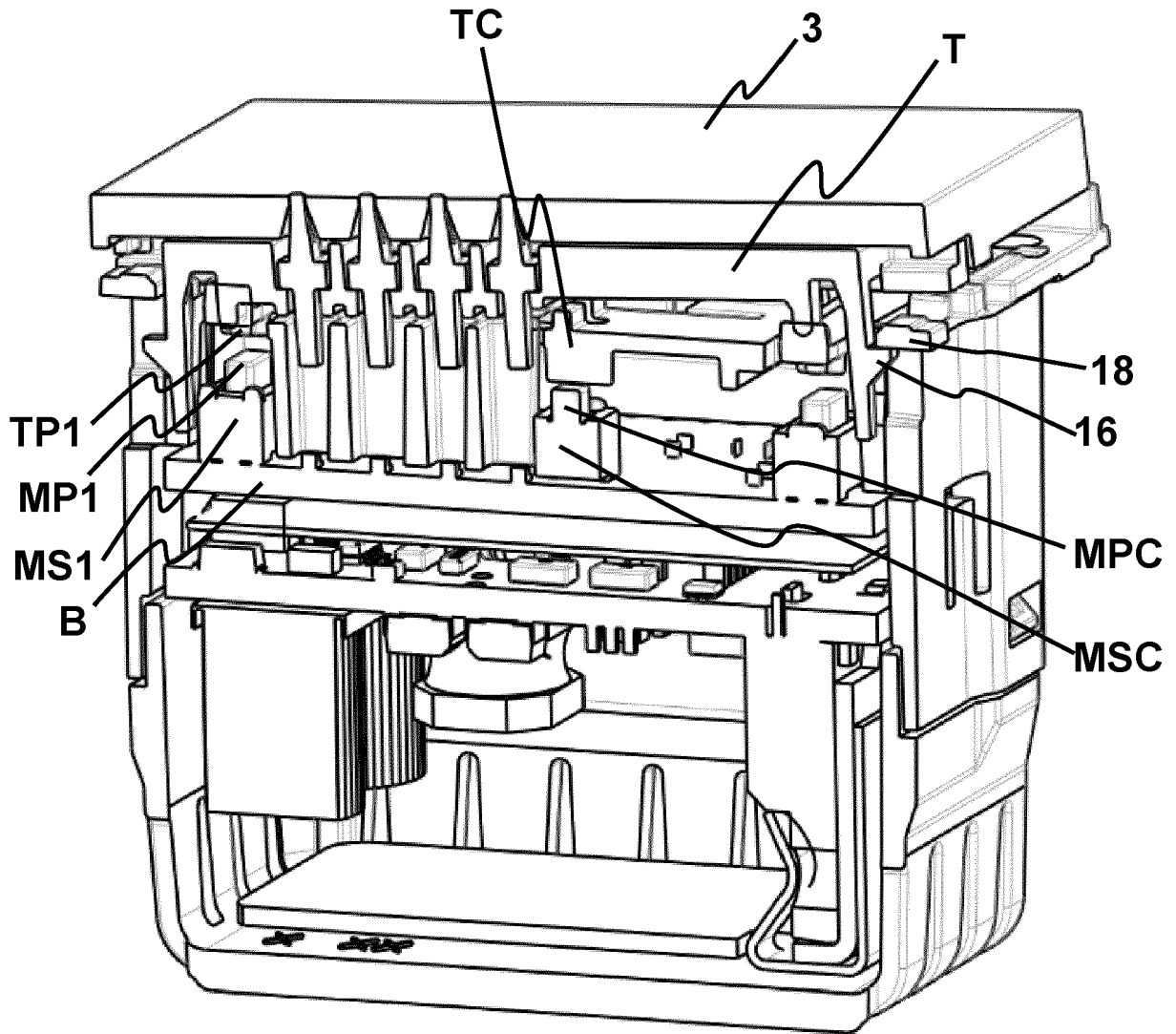
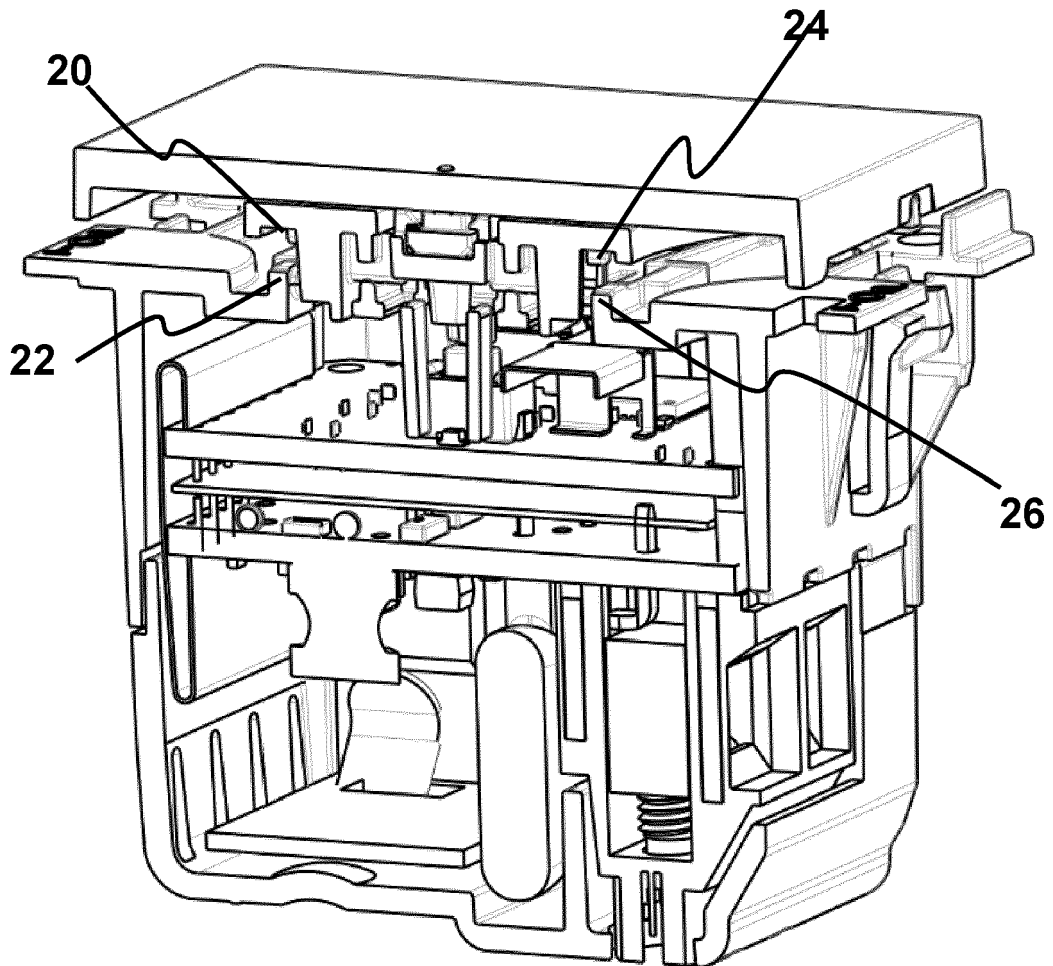

Fig. 6



**Fig. 7**

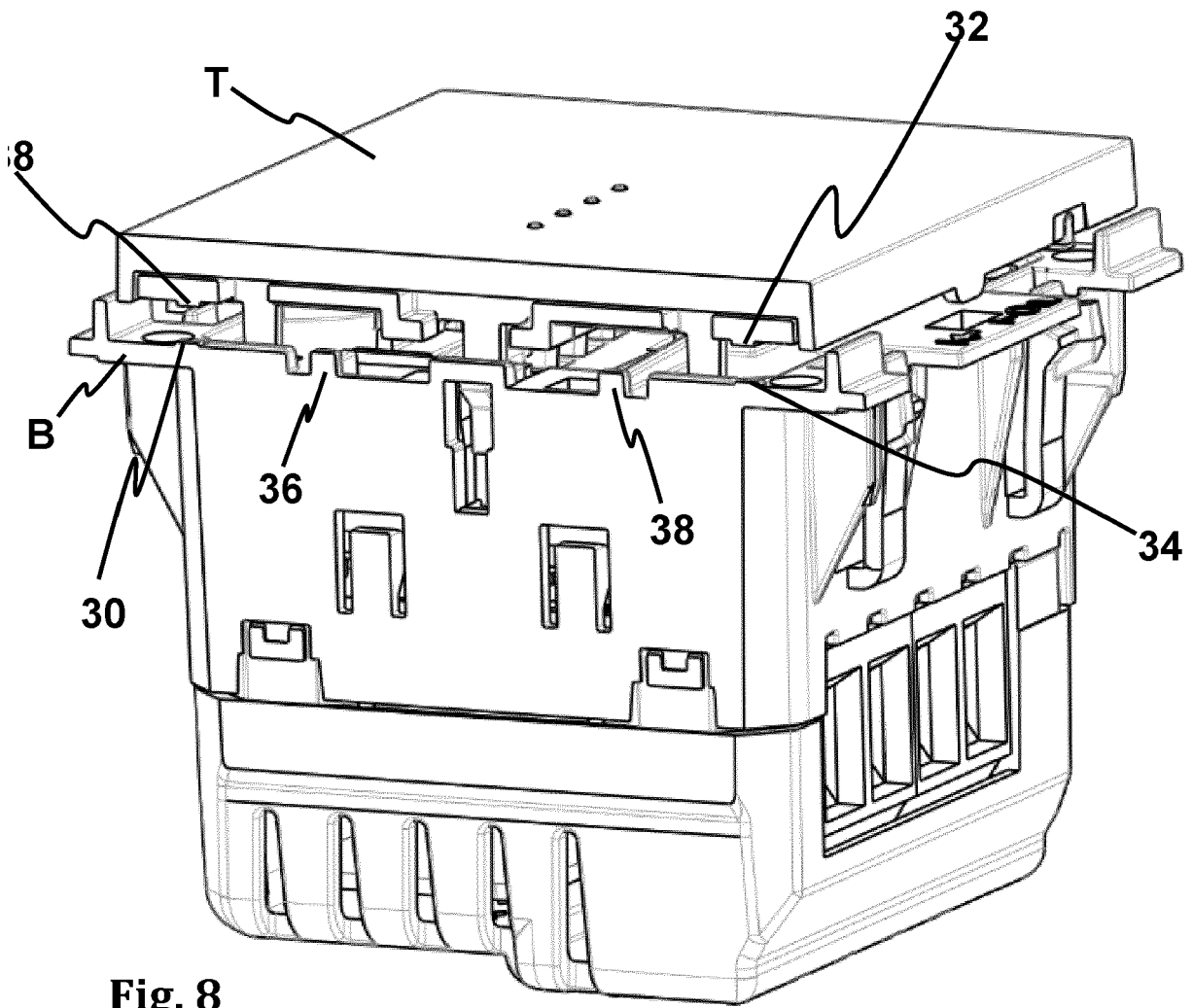

Fig. 8

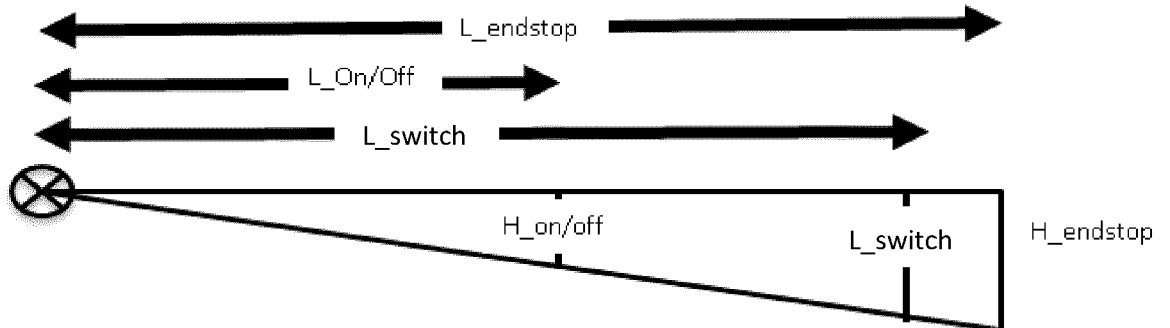

Fig. 9

Fig. 10

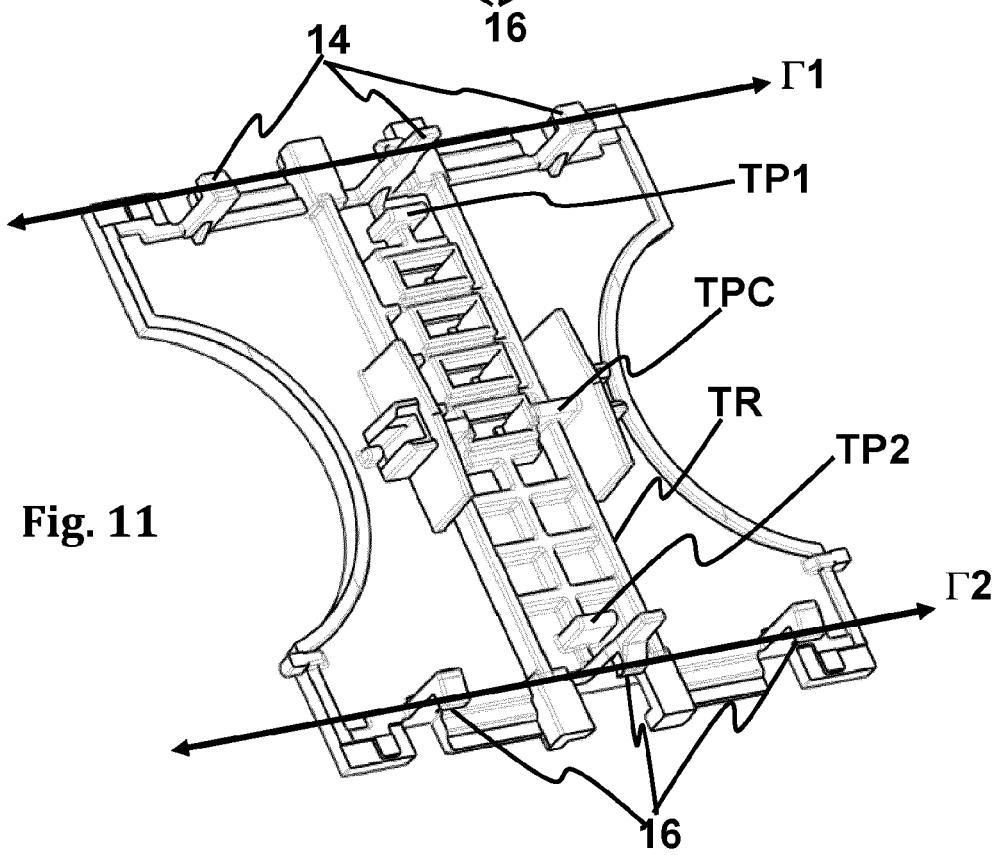
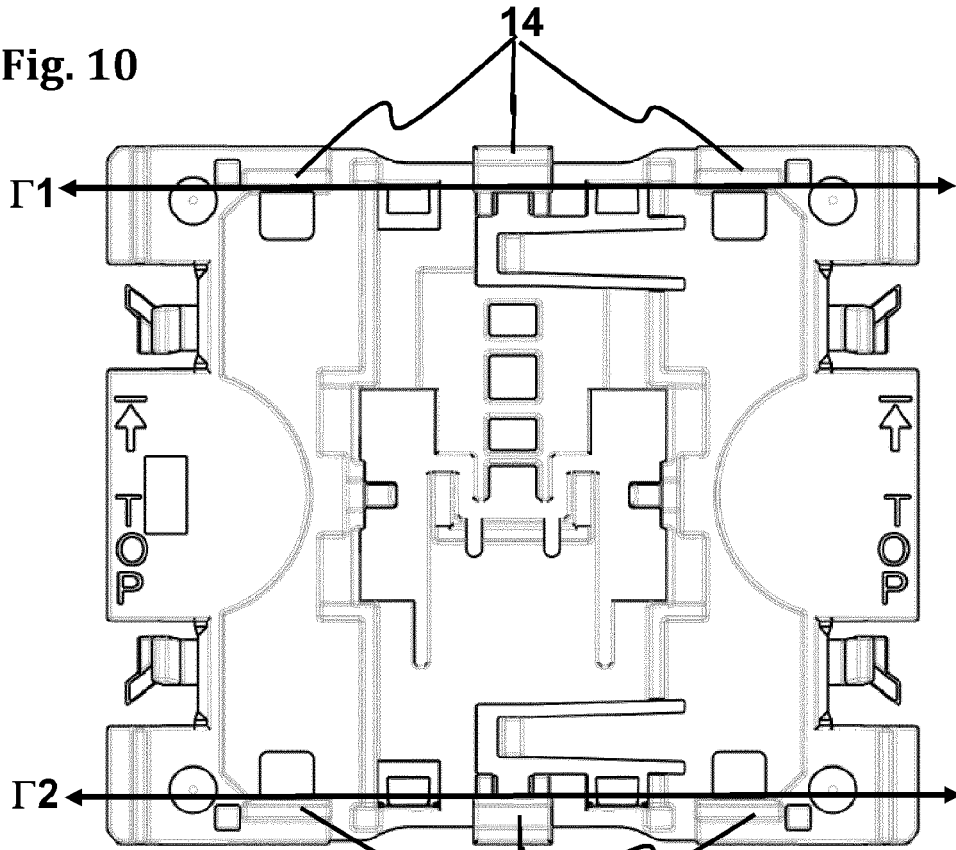

Fig. 11

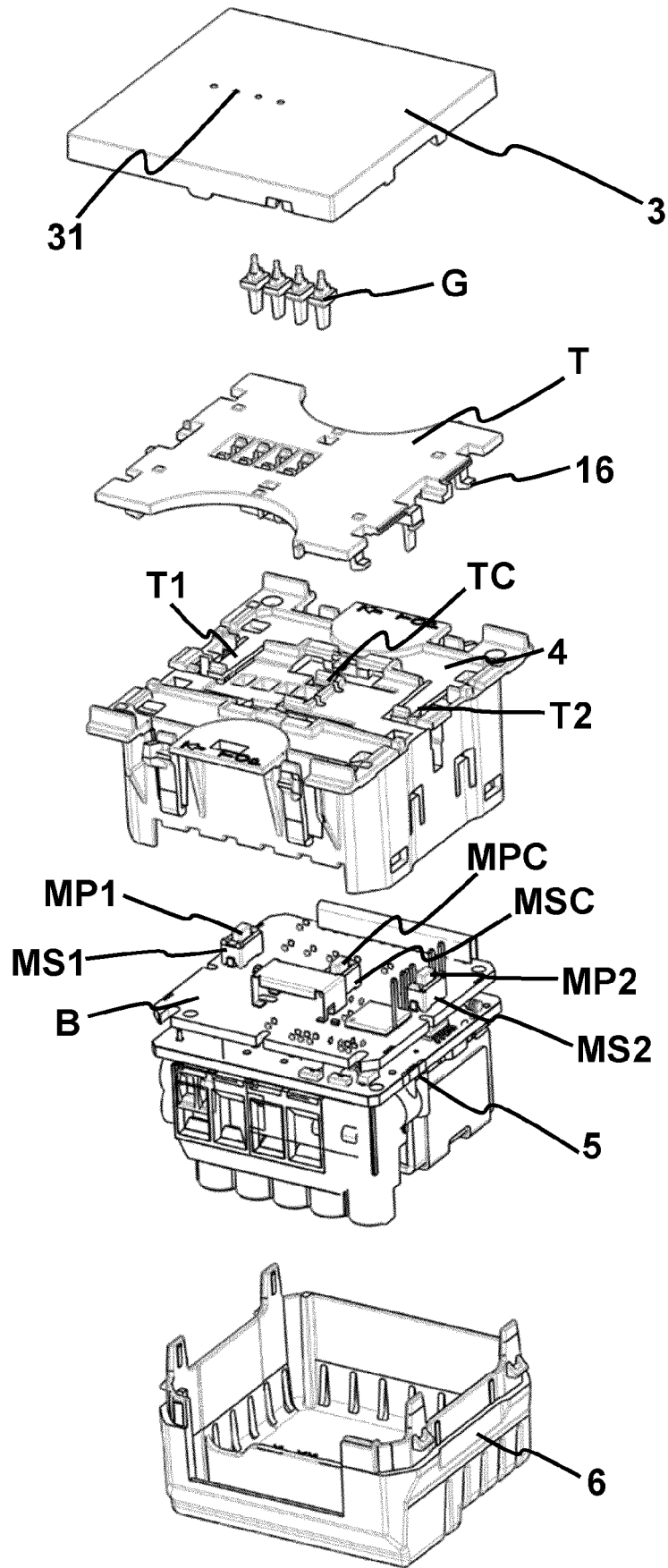

Fig. 12



EUROPEAN SEARCH REPORT

Application Number  
EP 20 38 3047

5

10

15

20

25

30

35

40

45

50

55

DOCUMENTS CONSIDERED TO BE RELEVANT			
Category	Citation of document with indication, where appropriate, of relevant passages	Relevant to claim	CLASSIFICATION OF THE APPLICATION (IPC)
A	EP 1 619 704 A1 (MERTEN GMBH & CO KG [DE]) 25 January 2006 (2006-01-25) * page 3, paragraph 0021 - page 5, paragraph 0029; figures 1-9 *	1-13	INV. H01H25/04  ADD. G05G9/047
A	EP 1 182 678 A1 (THOMSON LICENSING SA [FR]) 27 February 2002 (2002-02-27) * column 3, line 17 - column 4, line 31; figures 1-5 *	1-13	
			TECHNICAL FIELDS SEARCHED (IPC)
			H01H G05G
The present search report has been drawn up for all claims			
Place of search <b>Munich</b>		Date of completion of the search <b>16 April 2021</b>	Examiner <b>Pavlov, Valeri</b>
CATEGORY OF CITED DOCUMENTS X : particularly relevant if taken alone Y : particularly relevant if combined with another document of the same category A : technological background O : non-written disclosure P : intermediate document T : theory or principle underlying the invention E : earlier patent document, but published on, or after the filing date D : document cited in the application L : document cited for other reasons & : member of the same patent family, corresponding document			

EPO FORM 1503 03.02 (P04C01)

**ANNEX TO THE EUROPEAN SEARCH REPORT  
ON EUROPEAN PATENT APPLICATION NO.**

EP 20 38 3047

5 This annex lists the patent family members relating to the patent documents cited in the above-mentioned European search report.  
The members are as contained in the European Patent Office EDP file on  
The European Patent Office is in no way liable for these particulars which are merely given for the purpose of information.

16-04-2021

10	Patent document cited in search report	Publication date	Patent family member(s)	Publication date
15	EP 1619704 A1	25-01-2006	AT 370508 T DE 102004035321 A1 EP 1619704 A1 ES 2292063 T3	15-09-2007 16-02-2006 25-01-2006 01-03-2008
20	EP 1182678 A1	27-02-2002	NONE	

EPO FORM P0459

For more details about this annex : see Official Journal of the European Patent Office, No. 12/82