



①② **EUROPEAN PATENT SPECIFICATION**

④⑤ Date of publication of patent specification :  
**21.08.91 Bulletin 91/34**

⑤① Int. Cl.<sup>5</sup> : **E03F 1/00**

②① Application number : **88303325.0**

②② Date of filing : **13.04.88**

⑤④ **Vacuum sewage collecting system.**

③⑩ Priority : **13.04.87 NO 871539**

⑦③ Proprietor : **JETS SYSTEMER A/S**  
**Dragsund**  
**N-6080 Gurskoy (NO)**

④③ Date of publication of application :  
**19.10.88 Bulletin 88/42**

⑦② Inventor : **Hofseth, Olav**  
**Lanagjerdet 6**  
**N-6065 Ulsteinvik (NO)**

④⑤ Publication of the grant of the patent :  
**21.08.91 Bulletin 91/34**

⑥④ Designated Contracting States :  
**DE ES FR GB NL**

⑦④ Representative : **Allen, Oliver John Richard et al**  
**Lloyd Wise, Tregear & Co. Norman House**  
**105-109 Strand**  
**London, WC2R 0AE (GB)**

⑤⑥ References cited :  
**DE-A- 3 042 619**  
**FR-A- 2 050 775**  
**FR-A- 2 366 186**  
**GB-A- 2 017 188**

**EP 0 287 350 B1**

Note : Within nine months from the publication of the mention of the grant of the European patent, any person may give notice to the European Patent Office of opposition to the European patent granted. Notice of opposition shall be filed in a written reasoned statement. It shall not be deemed to have been filed until the opposition fee has been paid (Art. 99(1) European patent convention).

**Description**

The present invention relates to collecting arrangement for vacuum sewage collecting systems and comprises a vacuum tank which through a supply pipe is connected to toilets, drainage tanks for urinals, greywater tanks etc., and a vacuum pump which through a suction pipe provides the necessary vacuum in the vacuum tank.

Vacuum sewage collecting systems for toilets have already been known for several decades. Such systems were primarily developed for use onboard airplanes and railway trains. Especially with regard to the airplanes, it was necessary to reduce the amount of water being carried with the planes to reduce the total weight.

Thus, an important advantage with the vacuum drainage systems for toilets is that the amount of water being used for each flushing operation is very small. While the conventional toilets use 8-10 litres of water for each flushing operation, the vacuum toilets needs less than 1,5 liter.

From being used for purposes as mentioned above, the vacuum drainage systems have gone through further developments the last two decades and are now to a larger extent being used on board ships and on shore. Further advantages have also been revealed :

— The demands for sewage purification are steadily increasing. As the amount of flushing water is less than in conventional systems, the amount of sewage to be purified is reduced and the purification costs are lowered.

— The lack of fresh water (drinking water) due to dry spell, pollution and such, is steadily increasing. Vacuum sewage collecting systems contribute positively to reduce the fresh water consumption.

— In conventional sewage collecting systems the drain pipes and possible sewage collecting tanks have to be mounted in a down-stream arrangement relative to the toilets etc. (height of fall). This is not necessary for the vacuum sewage collecting systems as the vacuum drain pipes and vacuum sewage collecting tanks also may be mounted in an up-stream arrangement. The mounting arrangement for vacuum sewage collecting systems therefore are more flexible.

— The possibility of leakage from a vacuum sewage collecting system is less than with conventional systems as the sewage is transported by means of air under vacuum.

These are some of the advantages to be mentioned. However, the vacuum sewage collecting systems are also encumbered with practical as well as operational problems.

In a known type of vacuum sewage collecting system the vacuum in the vacuum tank is provided by means of a vacuum pump, while the sewage in the vacuum tank is pumped out of the tank by means of a separate centrifugal pump. To be able to empty the tank, the vacuum pump has to be stopped, resulting in operations stoppage (the toilets can not be used). It has also been revealed that the users are using the toilets for other purposes than what they were initially intended for, i.e. the users are throwing garbage in the form of plastics bags, bottle caps, hand towels, sanitary ware or the like into the toilets. Such articles tend to pack the impeller of the centrifugal pump and prevent emptying of the vacuum tank, which again results in operations stoppage and an increase in maintenance costs.

It is a main object of the present invention to provide a vacuum sewage collecting system which is not encumbered with the above disadvantages, i.e. where the package of the pumps is prevented and which is based on continuous operation.

It is also an object of the invention to provide a vacuum sewage collecting system which is less energy consuming, based on the fact that more efficient vacuum pumps are used.

The above advantages are achieved by means of a vacuum sewage collecting system as described in the characterizing part of the attached claim 1. Advantageous embodiments of the invention are described in the dependent claims 2-5.

The invention will now be further described by means of examples and with reference to the drawings in which :

- Fig. 1 shows a vacuum sewage collecting system according to the invention schematically, and
- Fig. 2 shows another embodiment of the vacuum tank for the system according to Fig. 1.

As will be apparent from Fig. 1, the vacuum sewage collecting system consists of a vacuum tank 1, which on one side is connected to a supply line 6 and on the other side is connected to a suction pipe 7 coupled to vacuum pumps 4.

The vacuum tank 1 is divided into two chambers by means of a "dividing plate" 10. In Fig. 1 the dividing plate consists of a grating, a perforated plate or the like, and is partly conical with a partly bent pipe piece 16 which protrudes downwardly from the centre of the plate 10 and partly in to the lower, first 8 of the two chambers 8 and 9. Sewage in the form of water mixed with stools, urine, sanitary ware etc. flows into the first chamber 8

from toilets, urinals etc. (not shown) through the supply pipe 6. Water, or more correctly, fluid components flowing into the first chamber 8 can freely flow into the upper, second chamber 9 through the grating 10. The solid components arriving in the first chamber 8 are, however, ground by means of a macerator or grinder 3 which is provided in connection with the lower part of the chamber 8 and is pumped together with the liquid present to the second chamber 9 via a connecting pipe 11.

The macerator may be a combined grinder/pump device, or a separately driven grinder which is connected to a separately driven pump. Further, the macerator may be continuously or intermittently driven. The kind of operation to be chosen in this connection depends upon the capacity of the macerator, the amount of material to be macerated and so on.

Sewage, air and ground, solid materials which is present in the second chamber 9, is pumped via the suction pipe 7 out of the chamber by means of a vacuum pump in the form of a screw pump 4. The sewage and the solid particles are further transported through the drain pipe 13 to a not shown storage tank, purifying plant or the like, while the air is ventilated through an air escape pipe 16.

In the schematic drawing of Fig. 1, the vacuum collecting unit is provided with two separately driven screw pumps 4, which by means of pipes 14, 15 and two-way valves 5, can be driven separately, or be coupled in parallel and driven simultaneously. This is done for safety reasons to avoid operational stoppage, and to maintain a reserve capacity for the unit.

The vacuum in the vacuum tank 1, is maintained on an adequate level, i.e. 30-40%, by means of the screw pumps 4 which is started and stopped by means of an operating unit, not shown. The pump operation unit may be in the form of a vacuum sensor (pressure switch) disposed in the tank 1 and which is coupled to a starter relay for the pumps.

To avoid loss of suction effect for the screw pumps 4, supply pipes 12 are coupled to the suction inlet of the pumps to supply feed water to these. The feed water is supplied via the pipes 12 from a feed water tank 2 which is disposed on the drain pipes 13. In the present example the feed water is sewage from the pumps 4. It is, however, also possible to use waste water or fresh water instead of sewage.

Applying screw pumps as vacuum pumps represents an important advantage with the present invention and is to a large extent made possible due to the fact that the solid materials in the vacuum tank are macerated before reaching the vacuum pumps. The advantages resides in that the screw pumps have higher efficiency and lower maintenance costs than other types of vacuum pumps.

Even if the present example teaches the use of screw pumps, it is within the frame of the invention also possible to use other types of vacuum pumps, like for example ejector pumps. Also when using these types of pumps the maintenance costs are reduced, as the clogging problems are eliminated.

Fig. 2 reveals another vacuum tank 1 according to the invention. Also in this example the vacuum tank is divided into two chambers 8, 9. The dividing plate consists, however, of a plate 17 which is provided with an upwardly protruding pipe 18. The pipe 18 reaches some distance up into the upper chamber 9, and connects this chamber with the lower chamber 8. Air entering the lower chamber 8 will flow through the pipe 18 and into the upper chamber 9, while the sewage together with solid particles entering the lower chamber 9 will be macerated by the macerator and thereafter transported to the upper chamber 9 via the connecting pipe 19.

The macerator is started by a signal from a level switch 20 which is disposed in the lower chamber 8 and is stopped by means of a timing relay. The object of the pipe 18 is, as indicated above, primarily to let the air flow freely into the upper chamber 9 to obtain equal pressure in the two chambers 8, 9. However, the pipe 18 will also serve as a return pipe if the sewage in the upper chamber reaches the level where the pipe 18 ends.

The advantage with the vacuum tank shown in Fig. 2, is that the macerator will be in operation only when necessary, i.e. when the sewage reaches above the level where the level switch 20 is activated. In the example shown in Fig. 1, the macerator has to be in operation longer periods of time to be sure that all of the solid components in the chamber is macerated.

In the previous examples the supply lines 6 and the macerator 3 is coupled to the lower chamber 8, whilst suction pipe 7 is coupled to the upper chamber 9. It is, however, within the frame of the invention possible to arrange these couplings opposite, i.e. by coupling the supply line 6 and the macerator 3 to the upper chamber 9 and by coupling the suction pipe 7 to the lower chamber 8. In such instance it is natural to use a macerator 3 in the form of a grinder without a pump and arrange this in close connection to the dividing plate 10, 17 so that the solid particles being present in the chamber 9, and which are ground by grinder, falls freely into the lower chamber 8.

Further, within the frame of the invention it is also possible to use a vertical dividing wall or plate, thereby having two side by side disposed chambers, instead of a horizontal dividing plate 10, 17 as shown in Fig. 1 and 2.

**Claims**

1. Vacuum sewage collecting system, comprising a vacuum tank (1) which through a supply pipe (6) is connected to toilets, drainage tanks for urinals, greywater etc., and a vacuum pump (4) which through a suction pipe (7) provides the vacuum in the vacuum tank (1) **characterized in that**  
 5 the vacuum tank (1) by means of an air and liquid permeable dividing plate or wall (10) is divided into two chambers, a first chamber (8) on to which the supply pipe (6) is connected and a second chamber (9) on to which the suction pipe (7) is connected, that a macerator or grinder (3) is disposed in connection with the first chamber (8), to grind solid particles and transport these together with the liquid (sewage) which is present in the first chamber (8) to the second chamber (9) through a connecting pipe (11), and that the vacuum in the vacuum tank (1) is generated by means of a vacuum pump (4) which is adapted to pump the liquid as well as the ground, solid particles from the tank (1) to a storage tank or the like.

2. Vacuum sewage collecting system according to claim 1, **characterized in that**  
 15 the vacuum pump (4) is in the form of a screw pump, or two or more separately pumps and by means of pipes (14, 15) parallel-coupled screw pumps which can be operated one at a time or simultaneously, and that the pump or pumps (4) are provided with feed water supply pipes (12) for supplying feed water to the pump inlets.

3. Vacuum sewage collecting system according to claim 2, **characterized in that**  
 the feed water supply pipes (12) is connected to a feed water tank (2) which is disposed on the drain pipe (13) for the screw pump, whereby the feed water is sewage coming from the vacuum tank (1).

4. Vacuum sewage collecting system according to claim 1, **characterized in that**  
 20 the dividing plate (10) is in the form of a perforated plate, a grating or the like.

5. Vacuum sewage collecting system according to claim 1, **characterized in that**  
 the dividing plate (17) is provided with a pipe (18) which reaches up, into the second chamber (9), whereby the lower chamber (8) is connected to the upper chamber (9) through said pipe (18), and that the macerator is started by a level switch (20) in the chamber (8) and is stopped by means of a timer switch or relay.  
 25

**Patentansprüche**

30 1. Vakuumsystem zum Sammeln von Abwasser, das einen Vakuumentank (1) umfasst, welcher durch eine Versorgungsrohr (6) mit Toiletten, Abwassertanks für Harnbecken, Grauwasser usw. verbunden ist, und eine Vakuumpumpe (4), die das Vakuum in dem Vakuumentank durch ein Saugrohr liefert, dadurch gekennzeichnet, dass

der Vakuumentank (1) in zwei Kammern mit Hilfe einer luft- und flüssigkeitsdurchlässigen Trennplatte oder Trennwand (10) in zwei Kammern aufgeteilt wird, einer ersten Kammer (8), an welche das Versorgungsrohr angeschlossen ist, und einer zweiten Kammer (9), an welche das Saugrohr (7) angeschlossen ist, dass ein Reisswerk oder Mahlwerk (3) in Verbindung mit der ersten Kammer (8) angeordnet ist, um feste Teilchen zu mahlen und diese zusammen mit der Flüssigkeit (Abwasser), welche in der ersten Kammer vorhanden ist, zur zweiten Kammer (9) durch ein Verbindungsrohr (11) zu transportieren, und dass das Vakuum in dem Vakuumentank (1) mit Hilfe einer Vakuumpumpe (4) erzeugt wird, die angeordnet ist, die Flüssigkeit als auch die gemahlene, festen Teilchen von dem Tank (1) zu einem Vorratstank oder dergleichen zu pumpen.  
 35  
 40

2. Vakuumsystem zum Sammeln von Abwasser nach Anspruch 1, dadurch gekennzeichnet, dass die Vakuumpumpe (4) in der Gestalt einer Schneckenpumpe oder zwei oder mehreren getrennt angetriebenen Pumpen ist, und mit Hilfe von Rohren (14, 15) parallel miteinander verbundenen Schneckenpumpen, die einzeln oder gleichzeitig betrieben werden können, und dass die Pumpe oder Pumpen (4) mit Speisewasserversorgungsrohren (12) vorgesehen sind, um den Pumpeingängen Speisewasser zu liefern.  
 45

3. Vakuumsystem zum Sammeln von Abwasser nach Anspruch 2, dadurch gekennzeichnet, dass das Speisewasserversorgungsrohr (12) mit einem Speisewassertank (2) verbunden ist, der auf dem Abwasserrohr (13) für die Schneckenpumpe angeordnet ist, wobei das Speisewasser von dem Vakuumentank (1) kommendes Abwasser ist.  
 50

4. Vakuumsystem zum Sammeln von Abwasser nach Anspruch 1, dadurch gekennzeichnet, dass die Trennplatte (10) in der Gestalt einer perforierten Platte ist, einem Gitter oder dergleichen.

5. Vakuumsystem zum Sammeln von Abwasser nach Anspruch 1, dadurch gekennzeichnet, dass die Trennplatte (17) mit einem Rohr (18) vorgesehen ist, das in die zweite Kammer (9) hinaufreicht, wobei die untere Kammer (8) mit der oberen Kammer (8) durch das Rohr (18) verbunden ist, und dass das Reisswerk durch einen Höhenschalter (20) in der Kammer (8) angestellt wird, und mit Hilfe eines Zeitschalters oder eines Relais ausgeschaltet wird.  
 55

**Revendications**

1. Système collecteur sous vide de tout-à-l'égout, prévoyant un réservoir à vide (1) raccordé par conduit d'amenée (6) aux toilettes, réservoirs de drainage des eaux d'urinoirs, boues et eaux sales, etc.. et une pompe à vide (4) assurant le vide par un conduit d'aspiration (7) au réservoir à vide (1), **caractérisé en ce que** par l'intermédiaire d'une plaque ou paroi séparatrice (10) le réservoir à vide (1) est divisé en deux chambres, dont la première chambre (8) à laquelle est raccordé le conduit d'amenée et une deuxième chambre (9) à laquelle est raccordé le conduit de vide (7), un broyeur ou décanteur (3) étant raccordé à la première chambre (8) pour broyer les matières solides et les transporter avec le liquide (boues et eaux sales) de la première chambre (8) vers la deuxième chambre (9) au moyen d'un conduit de raccord (11), le vide dans le réservoir à vide (1) étant assuré par une pompe à vide (4) adaptée pour pomper le liquide ainsi que les matières solides broyées depuis le réservoir (1) vers un réservoir d'entreposage ou autre.

2. Système collecteur sous vide de tout-à-l'égout, selon la revendication 1, **caractérisé en ce que** la pompe à vide (4) est sous forme de pompe à vis, ou de deux ou plusieurs pompes à commande séparée et par des conduits (14, 15) des pompes à vis reliées en parallèle admettant le fonctionnement simple ou simultané, la/les pompe(s) (4) comportant des conduits d'amenée d'eau (12) apportant l'eau d'amenée aux entrées de pompes.

3. Système collecteur sous vide de tout-à-l'égout, selon la revendication 2, **caractérisé en ce que** les conduits d'amenée d'eau (12) sont raccordés à un réservoir d'amenée d'eau (2) disposé sur le conduit de décharge (13) de la pompe à vis, l'eau d'amenée étant les eaux sales provenant du réservoir à vide (1).

4. Système collecteur sous vide de tout-à-l'égout, selon la revendication 1, **caractérisé en ce que** la plaque séparatrice (10) est sous forme de plaque perforée, grille ou autre.

5. Système collecteur sous vide de tout-à-l'égout, selon la revendication 1, **caractérisé en ce que** la plaque séparatrice (17) est munie d'un conduit (18) remontant dans la deuxième chambre (9), raccordant la chambre inférieure (8) à la chambre supérieure (9), et le décanteur est démarré par un rupteur de niveau (20) dans la chambre (8) et arrêté par un rupteur à minuterie ou un relais.

30

35

40

45

50

55

FIG. 1.

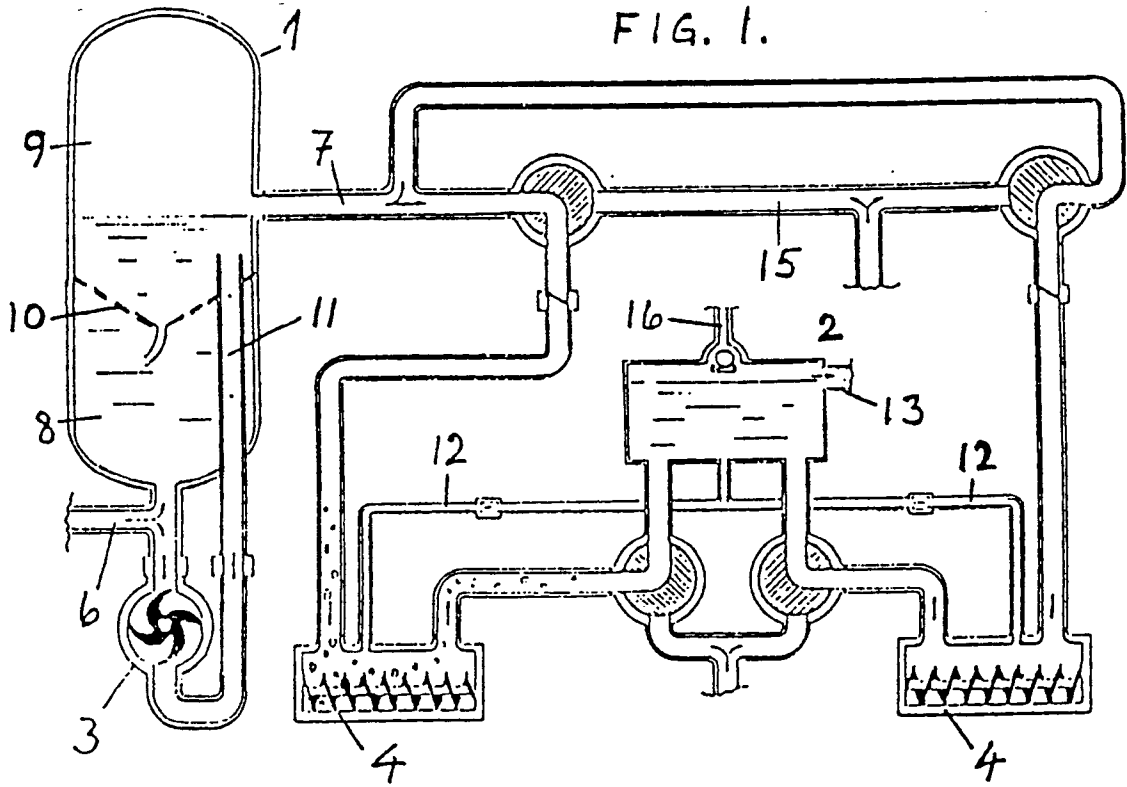

FIG. 2.

