

(19) World Intellectual Property  
Organization  
International Bureau



(43) International Publication Date  
25 August 2005 (25.08.2005)

PCT

(10) International Publication Number  
**WO 2005/076770 A2**

(51) International Patent Classification: **Not classified**

(21) International Application Number:  
PCT/US2004/001567

(22) International Filing Date: 15 January 2004 (15.01.2004)

(25) Filing Language: English

(26) Publication Language: English

(71) Applicant (for all designated States except US): **LUMETIQUE INC.** [US/CA]; 3940 Laurel Canyon Boulevard, Suite 339, Studio City, CA 91604 (US).

(72) Inventor; and

(75) Inventor/Applicant (for US only): **DECKER, DayNa, M.** [US/CA]; 3940 Laurel Canyon Boulevard, Suite 339, Studio City, CA 91604 (US).

(74) Agent: **HONG, David**; Law Office of David Hong, P.O. Box 2111, Santa Clarita, CA 91386-2111 (US).

(81) Designated States (unless otherwise indicated, for every kind of national protection available): AE, AG, AL, AM,

AT, AU, AZ, BA, BB, BG, BR, BW, BY, BZ, CA, CH, CN, CO, CR, CU, CZ, DE, DK, DM, DZ, EC, EE, EG, ES, FI, GB, GD, GE, GH, GM, HR, HU, ID, IL, IN, IS, JP, KE, KG, KP, KR, KZ, LC, LK, LR, LS, LT, LU, LV, MA, MD, MG, MK, MN, MW, MX, MZ, NA, NI, NO, NZ, OM, PG, PH, PL, PT, RO, RU, SC, SD, SE, SG, SK, SL, SY, TJ, TM, TN, TR, TT, TZ, UA, UG, US, UZ, VC, VN, YU, ZA, ZM, ZW.

(84) Designated States (unless otherwise indicated, for every kind of regional protection available): ARIPO (BW, GH, GM, KE, LS, MW, MZ, SD, SL, SZ, TZ, UG, ZM, ZW), Eurasian (AM, AZ, BY, KG, KZ, MD, RU, TJ, TM), European (AT, BE, BG, CH, CY, CZ, DE, DK, EE, ES, FI, FR, GB, GR, HU, IE, IT, LU, MC, NL, PT, RO, SE, SI, SK, TR), OAPI (BF, BJ, CF, CG, CI, CM, GA, GN, GQ, GW, ML, MR, NE, SN, TD, TG).

**Published:**

— without international search report and to be republished upon receipt of that report

For two-letter codes and other abbreviations, refer to the "Guidance Notes on Codes and Abbreviations" appearing at the beginning of each regular issue of the PCT Gazette.

(54) Title: CANDLE HAVING A PLANAR WICK AND METHOD OF AND EQUIPMENT FOR MAKING SAME

(57) Abstract: A candle having a body of a meltable fuel and a planar wick. When lit, the candle provides a unique flame formation, usable in a variety of decorative applications. The wick can be configured to evenly deplete the meltable fuel, while allowing for candles having relatively large and unique body configurations. The body of candle and/or the wick may include scented oil to promote the release of fragrance upon heating. The wick preferably is formed of wood, thereby providing an acoustic contribution to ambiance and improved combustion that generates less soot than conventional cotton wick candles.

WO 2005/076770 A2

## CANDLE HAVING A PLANAR WICK AND METHOD OF AND EQUIPMENT FOR MAKING SAME

### BACKGROUND OF THE INVENTION

**[0001]** Historically, candles served a functional purpose, but today they are further used to enhance decoration, aroma and ambiance. References to candles date back to at least 3000 B.C. in Crete and Egypt. Candle making as known today, began in the 13th Century. Candle molding machines were developed in the 15th Century. The braided wick was introduced in 1825. A continuous wicking machine was invented in 1834. Manufactured paraffin was introduced in 1850, providing an alternative to tallow. In 1854 paraffin and stearin were combined to create stronger candles, very similar to those used today. Through the past century, a number of "modern" technical innovations have been introduced to improve candle performance and production. Most of the focus has been towards advancing manufacturing methods (U.S. Pat. Nos. 3,964,858; 4,291,458; 4,830,330; 5,537,989; 5,927,965; 6,228,304), improved wick sustainers (U.S. Pat. Nos. 3,819,342; 4,332,548; 4,818,214; 5,690,484; 5,842,850; 5,961,318; 6,062,847; 6,454,561; 6,508,644), varying waxes formulations (U.S. Pat. Nos. 6,066,329; 6,342,080; 6,562,085; 6,599,334), and improving woven (i.e. braided) wick technology (U.S. Pat. Nos. 3,940,233; 4,790,747; 5,124,200). (The entire contents of all of the patents and other publications mentioned anywhere in this disclosure are hereby incorporated by reference in their entireties.)

**[0002]** Traditionally, a candle is made up of a single or multi combustible, porous core or wick surrounded by a fusible, flammable solid wax or wax-like material, such as absolute or blends of petroleum (paraffin) wax, mineral (montan) wax, synthetic wax (polyethylene or Fischer Tropsch), natural waxes (vegetable or animal) and clear candle waxes or "gels" (ETPA). Prior art shows candle wicks referring to cotton or cotton-like materials (i.e. rayon, nylon, hemp) woven, or braided and with or without a "self-supporting" core material such as metal, paper, cotton, polyethylene fiber or a stiffing agent. When a candle is lit, the heat from the flame melts the solid

fuel and the resulting liquid then flows up the wick by capillarity. This liquid is subsequently vaporized, the middle zone of the flame is where the vapor is partially decomposed, and the outer layer is marked by combustion of the vapor and the emission of carbon dioxide, water and other vapors into the atmosphere. The wick is the pivotal component for a candle to burn. Although there have been improvements in candle systems and wicks over the past century, there are still complications, limitations and hazards associated with prior wick technologies.

**[0003]** In August 1997, ASTM Subcommittee F15.45 was formed to address candle fire safety issues and to set safety standards. The frequency of injuries associated with candles approximately doubled from the mid-1980s to the mid-'90s. They also reported that there had been an increase in the number of candle recalls due to fire safety issues, including excessive flames in gel, terra cotta and metal container candles and various other types of wax candles. Candle sales increased 350 percent while injuries and deaths from candle related fires increased from thirteen to forty-two percent. The candle industry and the CPSC are currently working through ASTM to develop the necessary consensus standards to improve candle fire safety. The primary objective in this cooperative effort is to reduce injuries and deaths associated with candle fires.

**[0004]** Although there have not been standardized regulations set forth for candles, testing labs such as FTI/SEA and MTL-ACTS are actively involved in technical evaluations for candles with the National Candle Association (NCA) and/or ASTM. Candle burn testing involves stability, burn time, abnormalities, smoke/flaring, sputter, overflow, re-ignition, flame height, afterglow, external surface temperature (thermocouple), direct flame impingement, pool temperature, carbon deposit and soot emissions. Given that a wick's performance affects all these areas of testing, major improvements and focus must be directed towards advancing wick technology.

**[0005]** Prior candle wicks have been woven or braided for well over the last century. Such conventional wicks are woven from multiple fiber or filamentary yarns. The most commonly used yarn is cotton, although other natural fibers such as rayon, nylon or hemp have also been employed. Braided wicks are produced in various sizes, shapes and constructions to achieve the necessary performance (flame

height, wax pool size, self-trimming) and process (stability, self-supporting) requirements. The appropriate wick selection for a particular candle application includes type of weave, core, size (diameter or width) and density of wick. Even though wick selection is confined to braided wicks, there are over a thousand different types of braided wicks from which to choose. Consequently, the vast options of wicks may be a disadvantage to manufacturers or consumers, adding additional costs and time spent sourcing a proper wick. Ultimately, braided wicks still have many limitations.

**[0006]** Limitations include the wick's aesthetic appearance, and limited design and ambiance alternatives. Although there are thousands of different types of wicks available, they all consist of a white or natural colored, single strand woven material. Additionally, braided wicks only emit a silent, vertical flame.

**[0007]** Another limitation with braided wicks is that they do not provide enough capillary flow to optimize the performance of today's candles. When manufacturing a braided wick, increasing the picks per inch will increase the density of the wick (i.e. reduce the yield) and thereby reduce the size of capillaries, thus reducing the potential flame height or burn rate. Conversely, reducing the picks per inch will open the braid and reduce the density of the wick (i.e. increase the yield) and thereby increase the size of capillaries, thus optimizing the flame height or burn rate. However, such an increase in yield and burn rate from conventional braided candle wicks is limited by the fact that creating a more open structure with large capillaries creates a less stable wick which changes in characteristics when subjected to the tensions of the candle manufacturing process. In addition, the smooth surface of a braid reduces the functional surface area. The small capillaries and smooth functional surface area of the braided wick make it more difficult to create the required capillary flow rate in today's natural and gel waxes as well as candles that have high amounts of additives to modify a candle's hardness, color, burn rate and aroma (i.e. stearic acid, UV inhibitors, polyethylene, scent oils and color pigments).

**[0008]** Furthermore, today's candles come in different shapes, sizes, and types (i.e. filled, freestanding, taper, tealight and votive), ensuing a need for advanced wick materials and structures.

**[0009]** With the succession of oversized and oddly shaped candles (opposed to the traditional cylinder shapes), larger wax pool size and consumption are preferred. Due to wick height standardization by ASTM (i.e. three inches), braided wicks are limited in size and density, thus resulting in limitations in wax pool size, burn rate and consumption. For example, the thicker a cylindrical wick is, the higher its flame height. And flat wicks are restricted in width (i.e. 1/32-1/4 inch) due to the unsupported nature of a braided wick. Even if a "core" or stiffing agent were applied, the wick still remains too flexible. The wider and thicker the braided wick is the more unstable and hazardous it may be. Since the size of the wax pool is related to the burn rate and flame height, braided wicks typically cannot produce a large enough wax pool to consume the majority of a larger candle without compromising the standardized flame height. Characteristically, a braided wick can produce up to a three-inch diameter wax pool while maintaining a three-inch flame height.

**[0010]** A traditional six-inch diameter candle requires three braided wicks to maximize consumption. This results in additional manufacturing costs, irregular wax pools and potential hazards. For instance, when one wax pool spills into another, the leaking wax may create unstable flame heights and wick drowning.

**[0011]** Prior art shows the need to improve wick technology that allows the wick to burn for a longer period of time and consume more wax than existing wicking material. This was addressed in U.S. Pat. No. 4,790,747, whose wick comprises a single strand of tufted wire coil having a polyethylene and wax coating. One end of the coil is turned upward into a vertical section to form the lighting element and the other end of the wire is wound into a circular base such that it touches the base of the vertical section. Consequently, the wire core technology is manufactured with braided cotton or cotton-like material, generating the same analogous performance complications as disclosed.

**[0012]** One category of braided wicks is "self-trimming" or flat wicks (i.e. wicks that curl or bend to the outside of the flame). Although "self-trimming" wicks may reduce afterglow, they may curl to the point where the terminal ends bend into the wax pool or continue to curl into a spiral curl. This undesirable result can cause a self-trimming braided wick to increase in length so as to increase the amount of wick material, or functional surface area, above the melted wax pool, thereby producing a

continually increasing (i.e. unstable) flame height and wax pool. Conversely, it is important that a wick does not over-curl or bend to the point where the wick end touches the wax pool, causing the wick to extinguish and drown in molten wax. Consequently to re-ignite the candle, the wick needs to be located and "dug out" since the wax may cool and harden over the wick. The flat wicks are unsupported and very flexible.

**[0013]** The alternative category of braided wicks is "self-supporting" wicks. Self-supporting wicks (i.e. "cored wicks") are typically round in profile and use paper, cotton, metal or polyethylene fiber material in the core of the braid to stiffen the wick. Additionally, a stiffening agent such as wax-insoluble polymer or copolymer that depolymerizes or pyrolyzes may be used to support a flaccid wick. Although many core or stiffing devices are used, braided wicks remain flexible.

**[0014]** Due to the flexibility in supported or unsupported woven wicks, several hazards can occur. The majority of household candle fires are the result of a candle wick leaning to one side or another in filled or freestanding candles. Filled candles with flexible wicks, particularly those enclosed in plastic or glass containers, may overheat or contact the side of the container, causing breakage or other damage. Additionally, unsupported wicks may extinguish themselves, falling into the pool of molten wax. Further, freestanding candles with an unsupported wick may incur wax spillage due to a decentralized or irregular shaped wax pool.

**[0015]** Certain "self-supporting" wicks may consist of toxic core materials. In April 2003, the Consumer Product Safety Commission (CPSC) banned the manufacture and sale of lead-cored wicks and candles with lead-cored wick because they could present a lead poisoning hazard to young children. This ban became effective in October 2003. The federal ban applies to all domestic and imported candles and will allow the CPSC to seek penalties for violations of the ban. Unfortunately, it is very difficult for consumers to tell if the braided "cored wicks" contain lead.

**[0016]** An additional obstacle with prior art wicks involves keeping a braided candle wick trimmed to a ¼ inch length for proper burning, as recommended by ASTM, NCA and most candle manufacturers and testing labs. If a braided wick is not trimmed properly, carbon balls, excessive soot emissions and fire hazards may

occur. Candle manufacturers are not required and usually do not distribute a finished candle with a recommended wick size of ¼ inch.

**[0017]** Also, due to the nature of cotton-like material and especially "self-supporting" core material, a cutting device is needed to trim the braided wick. If a wick is positioned deep in a narrow candle jar or container, it may become difficult for conventional scissors or cutting device to trim off the excess long wick from the candle. Still, another problem is the difficulty to accurately measure a wick to the exact recommended ¼ inch length.

**[0018]** The primary obstruction of prior candle wicks is the emanation of excessive soot developments, resulting in smoke emission and carbon build up. Excessive soot occurs when a candle is burning as a result of the remains of carbon particles that have not been completely decomposed (burned) within the candle flame. Soot will either fully combust and burn off, released into the atmosphere as smoke, or grow into a carbon head or ball, otherwise known as "mushrooming" or "afterglow". Furthermore, carbon heads can detach from the wick and fall into the pool of liquid fuel, where they accumulate. In addition to creating a polluted looking candle, the liquid fuel may combust, thereby igniting the carbon heads, which become hot enough to vaporize and re-ignite resulting in "flashover." In freestanding candles, the carbon heads may heat up the wax and burn through the sides and bottom of the candle causing severe damage and fire hazards. In addition, the development of carbon heads (i.e. "afterglow") causes the emission of unwanted smoke or toxic fumes to linger for several minutes after being extinguished.

**[0019]** As a result of an increase in safety requirements and environmental issues, a Smoke Test Method Task Group, formed by ASTM, developed a method to assess the propensity of a candle to smoke. Candle manufacturers and testing labs can use a simple test to measure the smoke from a candle while it is burning that allows them to improve the performance of that candle. The standard test method was recently balloted in January 2003, and the task group will continue to work toward a final standard based on the ballot results.

**[0020]** In today's candles a wick sustainer is primarily used to provide lateral support to a wick in a candle to hold the wick in place during pouring of the wax-like material in a container or mold or to laterally support the wick when the hardened

wax liquefies, no longer supporting the braided wick. During the manufacturing of filled candles the wick is usually centrally positioned in the bottom of a container with an adhesive to seal the wick sustainer to the bottom. Many wick sustainers are difficult though to position centrally. Additionally, many wick sustainers are made of materials that are not heat resistant or have "self-extinguish" qualities resulting in the overheating of glass causing severe damage, such as by fracturing or cracking. Furthermore, the design of a wick sustain can either amplify or reduce the risk of "flashover." A variety of wick holders for braided wick technology have been designed over the past decade or so to reduce fire hazards and increase safety. See, e.g., U.S. Pat. Nos. 1,226,850; 1,267,968; 1,309,545; 1,320,109; 1,344,446; 1,505,092; 2,291,067; 2,324,753; 3,462,235; 3,998,922; and 4,381,914.

**[0021]** It is known in the art to manufacture "freestanding" candles by molding, and wherein a candle body is molded by casting the wax in a mold having a wick inserted therein. Maintaining the wicks centrally in the mold during such operation is a rather difficult procedure, due to the flexibility of braided wicks. For example, as molten wax cools, it shrinks, causing wick repositioning, which increases the risk of wax spillage as the candle burns.

#### **SUMMARY OF THE INVENTION**

**[0022]** Directed to overcoming the foregoing and other shortcomings and drawbacks of candle wicks and systems heretofore known, the present invention embodies a planar wick and the method and equipment to produce the same. In preferred forms, the present invention includes wood, wood-like or semi-wood wicks that provide improved capillary flow as well as increase the functional surface area. This candle wick provides additional decoration and an acoustic release. In accordance with principles of the present invention, a candle wick is provided which is particularly designed to burn efficiently in a candle system without producing undesirable smoke and carbon heading. In addition, the wicks are capable of creating a more stable and uniform wax pool diameter. The candle wick is designed to change the physical shape of the flame to thereby provide maximum burning efficiency. Candles of the present invention provide a safer, cleaner burning, decorative, multi-sensory alternative to the prior wick technology.



**[0023]** The present invention provides a candle having a body of a meltable fuel and a planar wick. The meltable fuel can be vegetable-based, paraffin, beeswax, carnauba, candelilla, polymers, polyolesters or other "fuels" as would be apparent to those skilled in the art from this disclosure. When the wick is lit, the candle provides a unique flame formation, usable in a variety of decorative applications. The wick can be configured to evenly deplete the meltable fuel, while allowing for candles having relatively large and unique body configurations. Optionally, the body of candle and/or the wick may include scented oil to promote the release of fragrance upon heating and the wick may comprise wood, thereby providing an acoustic contribution to ambiance, improved combustion that generates less soot than conventional candles.

**[0024]** It is recognized in the analysis of wood that a species or genus or a complete botanical affinity or family name is given. Each species is typically described in terms of its trade, distribution, tree and wood characteristics, including weight, gravity, drying and shrinkage, durability, preservation and toxicity. Wood species are broken down into hardwoods, softwood and tropical woods. There are over 160,000 hardwoods and over 100,000 softwoods available. If anatomical elements are large and irregular, the wood is described as having coarse and uneven texture. If these same features are small and evenly distributed, the texture is fine and uniform. Grain defines the arrangement or alignment of wood tissue; straight, spiral or interlocked. The durability, decay and drying and shrinkage qualities will also effect a wick's function.

**[0025]** The key factors in determining an ideal wood species for the use in a candle embodiment include: a fine to medium, uniform texture for a consistent burn; a generally straight and even, vertical grain; resistance to decay; durability (i.e. minimal shifting due to environmental or climate changes); little tendency to split; shock resistance; strong and stable.

**[0026]** The key factors in determining a wood species for the use in scent dispensing applications, such as for air fresheners and perfume delivery applications include resistance to decay; minimal shrinkage; strong and stable, permeable; and distinctive scents.

**[0027]** In a detailed aspect of a preferred embodiment of the invention, the wick is formed of wood selected from a group consisting of poplar, cherry, maple, wenge, oak, rosewood, and bamboo. The wood can have a moisture content of less than about six percent, or alternatively and preferably between ten and twelve percent. This wick is thereby comprised of a more rigid, viscous material that can produce a larger wax pool and longer burn rate without compromising the flame height.

**[0028]** According to another definition of the present invention a candle having a body of meltable fuel and a planar wick is provided. The wick can be made of wood, semi-wood or wood-like material. The wood can be selected from hardwood, softwood or tropical woods preferably with straight, vertical grains; fine to medium and uniform in texture; medium density; moderate to light weight; low shrinkage; excellent strength and stability and resistant to splitting. The semi-wood may be wood combined with cotton or cotton-like material and wood or wood bonded together with natural adhesives or resins, such as particle board. The wood-like material can be any material natural or manmade lamina, replicating rigid, solid sheet-like material, made from materials such as trees, shrubs, leaves and plant tissue and bark. The woodlike material consists largely of cellulose and lignin with vertical, straight grains and a uniform texture.

**[0029]** The fibrous rigidity of the wick of the present invention provides centralized wax pools, safe burning candles, and no wick drowning or wick bending. The wick is continuously stable while the candle burns and does not lean while the candle is being manufactured.

**[0030]** The wick can be bleached, dyed or printed on such as by printing a message or decorative pattern on the flat surface thereof.

**[0031]** The planar wood, semi-wood, wood-like wick may be dipped or coated with a wax to seal the wick from obstructive elements (i.e. fragrance, dyes, acids, oils or other agents) that may affect the capillary flow, therefore allowing the wick to burn more efficiently and consistently.

**[0032]** The absorbent wood material of the wick can be adapted to be used as wicks in a variety of applications. For example, porosity of the longitudinal exterior surface of a wick can be highly desirable in scent dispensing applications, such as

for air fresheners and perfume delivery applications. The length of the wick exposed to air may be controlled to regulate the rate of scent release.

**[0033]** The wick provides an acoustic crackling sound and depending on the combined fuel may emit more or less acoustic sound, as may be desired. Also, the species of wood and amount of viscous sticky substance (i.e. gum or resin) affects the volume of the sound; for example, the Rosaceae family of woods, emit a more acoustic crackling sound due to the integrated gum pockets in the wood.

**[0034]** The wick of the present invention advantageously burns cleanly without producing carbon heads, mushrooming or after glow. Due to the lack of carbon buildup, the wick when extinguished discontinues releasing soot within a minute of being extinguished. (In contrast, today's candles continue to release soot for approximately thirty seconds to five minutes.)

**[0035]** The wick can be trimmed by breaking the burn wick material off with fingers or a cutting device. Typically, the height of the wick above the wax is 1/8 to 3/16 inch. It is easier than braided wicks to trim and determine the correct height. The preferred height of the wick when the candle is manufactured and sold is 1/8 to 3/16 inch above the wax. The wick holder raises the wick 1/8 to 3/16 inch, thus, extending the wick that distance above the wax for proper burning.

**[0036]** The wick can be 1/8 to twenty inches in width depending on the size of the candle container or desired size of the free-standing candle. The height correlates to the size of the candle. The wick can be flat or curved vertically.

**[0037]** The wick thickness is determined by the type of wax; vegetable base waxes tend to need thicker wicks compared to petroleum based which is more incendiary. The width is determined by the size of the container verses the thermal flow. For example, a 3/8 inch width wick is typically placed in a three inch diameter petroleum-based pillar, whereas a 5/16 inch width wick is placed in a three inch vegetable-based pillar. A four inch round glass container may use a 1/2 inch width wick with paraffin wax while the same container with vegetable wax may use a 5/8 inch width wick.

**[0038]** The present invention wick burns cooler thus causing a longer burn rate, lower external temperature and lower container temperature. This is because the emissions of carbon dioxide, water and other vapors are released and burn up

causing cleaner combustion. Since the wick extends horizontally, the candle can consume more wax than a single wick than prior art candles, thereby causing longer burn rate and a larger wax pool.

**[0039]** The wick can be manufactured by cutting a log vertically from .019 to 0.30 inch and then laser or die cutting to an exact size for the desired candle system. Alternatively, the wick can be wood or woodlike particulars or particulated adhered or bonded together with a bonding material, pressed and cut to size. The candle can have a wick sustainer or holder, and the candle can be made of a fuel capable of melting to form a liquid pool and traveling by capillary action to a flame burning on the wick.

**[0040]** The wood may be from a family of hardwoods, softwood or tropical woods. The preferred wood qualities are: fine to medium, uniform texture, straight, even vertical grain, high to medium density and strength, light to medium weight and shock and split resistant. Preferred wood species or genus include but are not limited to: Adler, Cedar, Cherry, Cypress, Poplar, Silverbell, Spruce, Rimo, and Pillarwood. Cherry and Poplar are the most abundant and commercially available in the United States. Additional preferred species or genus of wood include: Aspen, Basswood, Beech, Birch, Hard Maple, Pacific Yew, Pine and Witch Hazel, due to their fine to medium, uniform texture; and straight, vertical grain as listed above, although these wood families tend to be heavier, denser and softer.

**[0041]** The present invention further relates generally to the field of candle making and in particular to a new and useful sustainer for a planar wick which extinguishes the candle flame and inhibits combustion of residual candle fuel in a container or freestanding for the candle at the end of the candle useful life. The present invention thus advantageously provides for a stable wick construction that improves candle safety and performance by centering the wick and remaining upright.

**[0042]** In another detailed aspect of a preferred embodiment of the invention, the candle further includes a wick holder having a base and a support for receiving the planar wick. Optionally, the wick holder is configured to hold a planar wick upright independent of the body.

**[0043]** In a method of manufacture, a planar wick supported by a wick holder is positioned within a mold and, thereafter, material of the body is poured into the mold. Once the material sets, the candle can be removed from the mold.

**[0044]** The wick holder can comprise a body having a top surface, bottom surface, a pair of upper walls connected to the top and bottom surfaces and a planer bore for receiving the wick passing through the two upper walls. A barrier extends horizontally through the side walls. And the barrier and body are made from noncombustible materials. The upper walls are preferably at least a half inch in height above the bottom of the candle. The raised wick holder is preferably the central position through the body for receiving a wick. The body is preferably 1/16 to 1/8 inch but it may be cylindrical, pyramid shapes, cube shaped or conical. The diameter is in direct correlation to the size of the diameter of the bottom of the candle or candle holder/container. This keeps the wick always centrally located.

**[0045]** The wick holder of the present invention differs from prior art wick holders in the following ways: it is designed to center and hold upright a planar wick, and it is easily inserted into a slit, between two flat walls which hold the wick upright. There is a centering line on the wick sustain to center the wick.

**[0046]** Another invention disclosed herein thus relates to a flame retardant wick holder and anti-flash wick support for a candle wick in a candle to additionally minimize the risk of flashover. Using a wick sustain to elevate the exposed portion of the bottom end of a wick from a supporting surface cuts the wick off from the fuel pool once the pool level drops below that portion of the wick, thereby extinguishing the candle and retaining a fuel pool on the supporting surface. This insures that a minimum melt pool remains throughout the lifetime of the candle, and also helps to keep extraneous material away from the flame. In other words, in addition to extinguishing the candle, elevating the wick also separates the primary flame from the extraneous material in the fuel pool as the pool lowers.

**[0047]** The wick holder or sustain can be made from polymers or ceramics and preferably polyethersulfone (PES) with a thickness of 1/32 inch and which is noncombustible and intumescent when heated, to assist in self-extinguishing and reducing the heat transferred from the wick sustain to the supporting surface.

**[0048]** The candle can be manufactured by positioning an elongate member in a desired wick location in a candle mold. The elongate member has the same width and thickness dimensions as the wick to be used. With the elongate member in position the molten wax is poured into the mold around the member. The wax is allowed to solidify and the member then pulled out, leaving (or forming) an elongate slot centered in the wax. The thin planar, substantial rigid wood or wood product wick is then inserted into the straight slot. The end of the wick is inserted into the retaining slot of a wick sustain device press fit into the bottom surface of the candle.

**[0049]** To manufacture a candle, a centering device of the present invention for planar wicks provides an improved apparatus and method for preparing and installing wicking in free-standing candle bodies and comprises in its preferred arrangement a station for forming a passageway in a formed candle body to maintain the wick centrally in the mold during such operation. The centering device can be manufactured in metal, polymers or ceramic, preferably polyethersulfane (PES) with a thickness of 1/32 inch or applied to and included in these mold compounds polyvinyl chloride, latex systems, silicon rubber systems, polysulfide rubber systems and polyurethane flexible mold compounds.

**[0050]** Other objects and advantages of the present invention will become more apparent to those persons having ordinary skill in the art to which the present invention pertains from the foregoing description taken in conjunction with the accompanying drawings.

#### **BRIEF DESCRIPTION OF THE DRAWINGS**

**[0051]** Embodiments of the present invention will now be described, by way of example only, with reference to the following drawing figures:

**[0052]** FIG. 1 is a perspective view of a candle in accordance with the present invention, the candle having a planar wick;

**[0053]** FIG. 2 is a cross-section view taken on line 2-2 of FIG. 1, the candle having a wick holder;

**[0054]** FIG. 3 is a plan view of the wick holder of the candle of FIG. 1;

**[0055]** FIG. 4 is a cross-sectional view of another preferred embodiment of a candle in accordance with the invention, depicting a body having zones of different melting points;

**[0056]** FIG. 5 is a perspective view of another preferred embodiment of a candle in accordance with the invention, depicting a body having an asymmetric configuration;

**[0057]** FIG. 6 is an exploded view showing candle-making equipment of the present invention;

**[0058]** FIG. 7 is a front view of an alternative holding device of the equipment of FIG. 6;

**[0059]** FIG. 8 shows a first process step using the assembled equipment of FIG. 8;

**[0060]** FIG. 9 shows a second process step of the present invention;

**[0061]** FIG. 10 is an enlarged sectional view showing the wick sustain device of FIG. 9 in position in the candle;

**[0062]** FIG. 11 is a perspective view of the wick sustain device of FIGS. 9 and 10 illustrated in isolation;

**[0063]** FIG. 12 is a top view thereof;

**[0064]** FIG. 13 is a side view thereof;

**[0065]** FIG. 14 is a bottom view thereof; and

**[0066]** FIG. 15 is a cross-sectional view taken on line 15-15 of FIG. 12.

#### **DETAILED DESCRIPTION OF PREFERRED EMBODIMENTS OF THE INVENTION**

**[0067]** With reference to the illustrative drawings, and particularly to FIG. 1, there is shown a candle shown generally at 100 having a body 120 of a meltable fuel and a planar wick 140. When lit, the candle 100 provides a unique flame formation usable in a variety of decorative applications. Optionally, the candle body 120 and/or the wick 140 may include scented oil to promote the release of fragrance upon heating, may be bleached, dyed or printed on for decor, and can be configured to provide an acoustic contribution to ambiance.

**[0068]** The material and thickness of the wick 140 are selected to promote the candle's functionality as well as the candle's contributions to ambiance. In a

presently preferred embodiment, the wick 140 is made of wood, semi-wood or wood-like material and, when lit, provides a pleasant crackling sound and burns more thoroughly with less carbon heading and sooting than conventional wicks. Processed wood materials such as particleboard and fiberboard may also be used. Overall, woods having relatively straight, condensed grains and without checking make effective wicks. In contrast to traditional wicks, which require periodic trimming, maintenance of wood wicks can be performed with or without any tools. Rather, burned edges of wood wicks can be removed with the user's fingers, before relighting.

**[0069]** Empirical testing has shown that woods such as poplar, cherry, maple, wenge, oak, rosewood, and bamboo are effective with both paraffin-based and vegetable oil-based waxes, and are effective when used in conjunction with waxes having melting points between one hundred and ten degrees and one hundred and ninety degrees Fahrenheit. For example, a wick formed of cherry wood having a thickness between 1/53 inch and 1/8 inch, used in a body of a paraffin or vegetable oil-based wax provides an even burn and a pleasant crackling sound. Hard non-brittle, tight grain woods work best. And cherry is preferred over other species of wood for some applications because its higher oil content gives it more of a desirable crackling sound when burning. Although testing has shown that some woods, such as walnut, ash, birch, pearwood, sapele, pommele, zebrawood, lacewood, mahogany, pine, teak, ebony, and various burls, are not as effective, these woods are still within the scope of the invention. Woods having a moisture level of less than about six percent have been found to work, but moisture contents of between ten and twelve percent are preferred.

**[0070]** The wick 140 can have thicknesses of .019-.028 inch, and widths of 1/8 to three inches are the safest. The wick height depends on the candle height and for example can be 1/2 inch to six feet. Wick dimensions can relate to the type of wax used. While wicks for paraffin candles will be thinner and narrower (approximately .019-.023 inch), wicks for vegetable-based waxes will be thicker (approximately .023-.028 inch). Palm and soy are the main components of vegetable-based waxes. It is also within the scope of the invention to use a paraffin-vegetable-based wax mixture. The wax, fragrance and dye used can all affect the desired wick dimensions.



However, as an example for a three-inch diameter candle, a 3/8-5/8 inch wide wick can be used.

**[0071]** One way of forming the wood wicks is to have traditional manufacturers of wood veneers for doors, windows and the like, cut the veneers in a certain way. They are then die cut to a specific size, and pressed and dried as needed, since if the wood wick is too moist it may not produce a consistent flame. A moisture content of eight to twenty percent is preferred.

**[0072]** Cotton or cotton-like materials can be incorporated into the wood wick construction. One example is to sandwich a piece of cotton between the sheets of wood and seal the sandwiched construction with wax. Another example is to make a wood particle/powder fiberboard with small bits of cotton incorporated therein.

**[0073]** With continued reference to FIG. 1, the wick 140 is generally straight, as viewed from above the candle and is relatively thin and pliable. In other embodiments, the wick 140 may be configured in various shapes, bent or straight, as desired. For instance, the wick can be configured, in any decorative shape as viewed from the top, such as an arc, circle, square, triangle, heart, or an alphanumeric shape. Also, the size and shape of the wick are selected to provide even depletion of the meltable material throughout the life of the candle 100, even for unique body configurations (see FIG. 5). For example, the wick of a free-standing candle is sized to create a pool of wax that reaches within 1/8 to 1/2 inch from the edge of the body 120. Beneficially, the planar wick 140 allows for a larger candle that depletes evenly. Each candle 100 can have one or more wicks 120 configured in the shape of a sheet. Optionally, the wick 140 can be soaked in scented oil to promote the release of fragrance when burning, or can be bleached, dyed and printed on for decor.

**[0074]** Referring now to FIGS. 2 and 3, the candle 100 further includes a wick holder 160 that aids both in the manufacture and use of the candle. The wick holder has a base 180 and a support 200 for receiving the wick. The wick holder can be configured to hold a wood wick upright independent of the body 120. In this embodiment, the base 180 has a width W1 of about 0.05 inch and the support 200 has a width W2 of about 0.09 inch. The support defines a spacing 220 of about 0.02 inch for receiving the wick.

**[0075]** With reference now to FIG. 4, the body 120 can be formed to have regions with different melting points. In this embodiment, the body has an inner core 220 of a first melting point and an outer core 240 of a second melting point. The inner core melting point may be in the region of two hundred to two hundred and forty degrees Fahrenheit, and the external region melting point may be between one hundred and twenty and one hundred and sixty degrees Fahrenheit. Although, the preferred melting point of inner core is between one hundred and forty to one hundred and sixty degrees Fahrenheit and the outer core is between one hundred and twenty-five and one hundred and thirty-five degrees Fahrenheit. This may avoid the external appearance of cracks in the candle. In a preferred embodiment, the inner core 220 has a width  $W$  of at least 1.5 inches to ensure that the heat of the wick 120 does not promote the fast melting of the external region 140. The external region may have a thickness of at least one inch.

**[0076]** The wick 120 should be positioned accurately in the desired location. If it leans to one side on the other as can occur by the tension of the cooling wax, the candle 100 will burn unevenly. To ensure an accurate positioning of the wick 120, unique equipment and manufacturing method have been developed. And the equipment and method can best be understood from FIGS. 6-10, and the discussion below.

**[0077]** Referring thereto it is seen that a centering device 300 is provided which centers an elongate member 320, a flat metal, ceramic or plastic rod, in the candle mold 340. More specifically, the holding device, piece 360 is snap fit via a button in the middle of the centering arms (or wings) 380 to form the centering device 300. The elongate member 320 is inserted down into the holding device 360 and held in place by its resilient fingers 300. The fingers 380 can accommodate elongate members (and thus subsequently wicks) of different widths. An alternative holding device construction is shown in FIG. 7 generally at 400.

**[0078]** On bottom surfaces of the centering arms are a plurality of protrusions, 420 having the same size and spacing on both sides. The protrusions define grooves 440 for fitting onto the rims 460 of molds 346, as can be seen in FIG. 8. The different spaced grooves 440 allow the centering device 300 to be placed on

molds 340 of different diameters and still accurately hold and center the elongate member 320 in the mold.

**[0079]** With the centering device 300 in place on the mold 340 and the elongate member (flat rod) 320 centered in the mold as shown in FIG. 8, the desired amount of molten wax 480 is poured into the metal or polyethylene mold 340 around the elongate member 320. The wax 480 is allowed to solidify (which can typically take at least two hours to solidify in a small candle and up to twenty-four hours in a large candle, depending on the type of wax and wax ingredients), and the elongate member 320 pulled out to define a slot 500 in the solidified wax 520, as illustrated in FIG. 9, where the wax is shown removed from the mold. The wick 540 (140) can be dipped or coated with wax before being inserted into the slot 500. This seals the wick 540 so that the dyes and fragrances of the candle wax 540 will not be absorbed into the (porous) wick.

**[0080]** A wick sustain device 600 is press fit into the bottom of the candle with the slot 620 thereof aligned with the candle slot 500 and a label (not shown) can be applied to the candle bottom over the bottom of the wick sustain device 600. The ("planar wick") wick 540 is inserted into the slot 500 in the wax down into the slot 620 of the wick sustain device 600, as illustrated in FIG. 10. The wick 540 is thereby consistently straight and accurately positioned. When the candle burns down to a short height, the wick sustain device 600 holds the wick 540 up. The wick 540 should initially extend up between 1/16/ to 1/4 inch, and preferably 1/8 or 3/16 inch, above the top surface of the candle. If it is too tall, the flame is too high. If it is too short, it is difficult to light. When relighting it, the burnt ash should be removed by hand so that the wood wick 150 extends up about 3/16 inch.

**[0081]** The wick sustain device 600 is shown in isolation in FIGS. 11-15. It is seen to include a round base member 640 and structure 660 secured thereto and defining the upwardly facing wick-receiving slot 620. The structure is essentially two spaced plates 680, 700, one taller than the other so that the wick is easier to install and is held straight upright. The slot 620 is 0.5 inch long, 1.5 inch wide, and 0.35 inch deep, but not limited to these proportions or dimensions. The base member 640 can have a diameter of two inches.

**[0082]** With the wick 540 in place, a finishing step -- a topping off -- can be conducted. Additional wax can be poured on top of the candle and a heat gun used to smooth it out and put a glaze on it.

**[0083]** Standard cotton wick candles have a tall flame height and a small pool size. So for larger candles, more cotton wicks are used for a single candle. This creates inconsistent wax pool and flame height and does not efficiently use the candle. Thus, with the present invention a single longer wick 540 (e.g., 1 ¼ inches for a six inch candle), with a safe flame height, can be used. Due to a cooler burn the candle lasts longer.

**[0084]** It should be appreciated from the foregoing description that the present invention provides candles usable in a variety of decorative applications and having unique flame formations. Optionally, the candle may include scented oil to promote the release of fragrance upon heating and the wick can be made of wood, semi-wood or wood-like material with a straight, vertical grain to provide an acoustic contribution to ambiance when lit. The present invention thus provides a candle having improved combustion, that provides a unique flame formation, that has a wick that is safer, remains rigid throughout its use, improves combustion and that makes an acoustic contribution to ambiance.

**[0085]** From the foregoing detailed description, it will be evident that there are a number of changes, adaptations and modifications of the present invention which come within the province of those skilled in the art. The scope of the invention includes any combination of the elements from the different species or embodiments disclosed herein, as well as subassemblies, assemblies, and methods thereof. However, it is intended that all such variations not departing from the spirit of the invention be considered as within the scope thereof.

**What Is Claimed Is:**

1. A candle comprising:  
a body of meltable fuel; and  
a thin flat elongate wood or wood product wick disposed in the body and having an upper end extending above an upper surface of the body.
2. The candle of claim 1 wherein wood grain of the wick is generally straight and vertical.
3. The candle of claim 1 wherein the wick has gum pockets.
4. The candle of claim 1 wherein the wood has a moisture content of ten to twelve percent.
5. The candle of claim 1 wherein the wood family of the wick is *Prunus Serotina*.
6. The candle of claim 1 wherein the species of wood of the wick is Hardwood.
7. The candle of claim 6 wherein the family of the wood of the wick is Cherry, Poplar, Maple, Birch, Beech, Basswood, Aspen, Yellow Buckeye or Oak.
8. The candle of claim 1 wherein the species of the wood of the wick is Softwood.
9. The candle of claim 8 wherein the family of the wood of the wick is Cedar, Spruce, Cypress, Pine, Pacific Yew, Silverbell or Witch Hazel.
10. The candle of claim 1 wherein the species of the wood of the wick is Tropical Wood.
11. The candle of claim 10 wherein the family of the wood of the wick is Rimo, Pillarwood, Wenge, Rosewood or Bamboo.

12. The candle of claim 1 wherein the wood of the wick has a moisture content of six to fourteen percent.
13. The candle of claim 1 wherein the meltable fuel is petroleum (paraffin), mineral (montan), synthetic wax, clear candle waxes, or "gels"
14. The candle of claim 1 wherein the meltable fuel is a beeswax, carnauba, candelillia or vegetable-based wax.
15. The candle of claim 1 wherein the meltable fuel includes at least one of stearic acids, UV inhibitors, polyethylene, scent oils, or color pigments.
16. The candle of claim 1 wherein the meltable fuel is paraffin.
17. The candle of claim 16 wherein the wick has a thickness of .019-0.23 inch.
18. The candle of claim 1 wherein the meltable fuel is a vegetable-based wax.
19. The candle of claim 18 wherein the wick has a thickness of .022-.028 inch.
20. The candle of claim 18 wherein primary components of the vegetable-based wax are palm and soy.
21. The candle of claim 18 wherein primary components of the vegetable-based wax are selected from the group of palm, cotton, olive, linseed, castor, peanut, jojoba and soy.
22. The candle of claim 1 wherein the meltable fuel is a mixture of paraffin and a vegetable-based wax.

23. The candle of claim 1 wherein the body has a diameter of approximately one to six inches and the wick has a width of 1/8 to two inches.
24. The candle of claim 1 wherein the body has a diameter of approximately six to twelve inches and the wick has a width of 1/8 – six inches.
25. The candle of claim 24 wherein the number of the wicks in the candle is between one and twelve.
26. The candle of claim 1 wherein the body has a diameter of approximately twelve to twenty-four inches and the wick has a width of 1/8 to twenty inches.
27. The candle of claim 26 wherein the number of the wicks in the candle is between one and twenty.
28. The candle of claim 1 wherein the wood or wood product comprises two sheets of wood with a flat piece of cotton sandwiched therebetween.
29. The candle of claim 1 wherein the wick comprises pressed wood with bits of fiber and adhesive in the pressed wood.
30. The candle of claim 30 wherein the fibers are cellulose materials, cotton, hemp, rayon, linen, paper and /or flax.
31. The candle of claim 29 wherein the adhesive is resin, gum, or natural glue.
32. The candle of claim 1 wherein the body is cylindrical and has a diameter of six inches and the wick is at the axial center of the body.
33. The candle of claim 32 wherein the wick has a width of one and 1/4 inches.
34. The candle of claim 1 wherein the wick is sealed with wax.

35. The candle of claim 1 wherein the wick substantially comprises cellulose and lignin.
36. The candle of claim 1 wherein the wick comprises wood particles and gum.
37. The candle of claim 1 wherein the wick is bleached.
38. The candle of claim 1 wherein the wick is dyed.
39. The candle of claim 1 wherein the wick has printed images.
40. The candle of claim 38 wherein the meltable fuel is synthetic wax, clear candle waxes or "gels".
41. The candle of claim 1 wherein the wick is configured in a selected decorative shape as viewed from above.
42. The candle of claim 1 wherein the wick is straight or curved vertically.
43. The candle of claim 1 wherein the body is cylindrical, elliptic, orbicular, parallelepiped, polyhedron, or organic form and has a diameter of two to twelve inches and the wick is at the axial center of the body.
44. The candle of claim 42 wherein the wick has a width of  $\frac{1}{4}$  inch to six inches.
45. The candle of claim 1 wherein the body is cylindrical, elliptic, orbicular, parallelepiped, polyhedron, or organic form and has a diameter of twelve to twenty-four inches and the wick is at the axial center of the body.
46. The candle of claim 45 wherein the wick has a width of one inch to twelve inches.



47. The candle of claim 1 wherein the wick has a thickness of .019-.028 inch and a width of 1/8 to twelve inches.
48. The wick of claim 46 wherein the primary thickness of the wick is .023 - .026 inch.
49. The wick of claim 46 wherein the primary width of the wick is 3/16 to three inches.
50. The candle of claim 47 wherein the wick has a height of 1/2 inch to four feet.
51. The candle of claim 1 wherein the wick has a height of one inch to six feet.
52. The wick of claim 51 wherein the wick has a primary height of one to nine inches.
53. The candle of claim 1 further comprising a wick holder in a base of the body, the wick holder having an elongate slot in which a lower end of the wick is received.
54. The candle of claim 53 wherein the slot has a width of 1/4 to twelve inches and a thickness of .018 to .03 inch.
55. The candle of claim 1 wherein the wick is rigid such as to be capable of being freestanding.
56. The candle of claim 1 wherein the wick is rigid such as to be capable of being vertically, flat comprising a wick holder.
57. The candle of claim 1 wherein the wood or wood product is a pressed wood particle/powder product or a high density fiberboard material.

58. The candle of claim 1 wherein the wick extends between 1/16 to 1/4 inch above the upper surface.
59. The candle of claim 1 wherein the fuel is a paraffin-based fuel and the wick extends 1/8 inch above the upper surface.
60. The candle of claim 1 wherein the fuel is a vegetable-based fuel and the wick extends 3/16 inch above the upper surface.
61. The candle of claim 1 wherein at least one of the body and the wick includes scented oil.
62. The candle of claim 1 wherein the wood or wood product is selected from the group of poplar, cherry, maple, wenge, oak, rosewood and bamboo.
63. The candle of claim 1 wherein the wood or wood product has the wood grain thereof extending longitudinally on the wick.
64. The candle of claim 1 further comprising a container having the body disposed therein.
65. A candle comprising:  
a body formed of a meltable fuel; and  
a planar wick disposed in the body and having an upper end extending beyond an upper surface of the body.
66. The candle of claim 65 wherein the meltable fuel is petroleum (paraffin) wax, mineral (montan) wax, synthetic wax, and clear candle waxes or "gels".
67. The candle of claim 66 wherein the wick has a thickness of .019-0.23 inch.

68. The candle of claim 65 wherein the meltable fuel is a beeswax, carnauba, candelillia or vegetable-based wax.
69. The candle of claim 68 wherein the wick has a thickness of .022-.028 inch.
70. The candle of claim 65 wherein the wick is rigid so as to be capable of being freestanding.
71. The candle of claim 65 wherein the wick is made of wood or a wood product.
72. The candle of claim 71 wherein the wick is made of poplar or cherry wood.
73. The candle of claim 71 wherein the wick is made of a pressed wood particle or powder product.
74. The candle of claim 71 wherein the wick is made of a high density fiberboard material.
75. The candle of claim 71 wherein the wick has a width of between 1/8 and 3 inches.
76. The candle of claim 71 wherein the wick has a moisture content of between ten and twelve percent.
77. The candle of claim 71 wherein the wick is made of a cotton and wood construction.
78. The candle of claim 71 wherein the wick has a width of approximately 1 ¼ inches and the body has a diameter of approximately six inches.
79. The candle of claim 71 wherein the wick extends between 1/16 and 3/16 inch above the upper surface.

80. The candle of claim 65 wherein the wick extends 1/8 inch above the upper surface.
81. The candle of claim 65 wherein the fuel is paraffin.
82. The candle of claim 65 wherein the fuel is a vegetable-based wax.
83. The candle of claim 82 wherein primary components of the vegetable-based wax are palm, cotton, olive, linseed, castor, peanut, jojoba and soy.
84. The candle of claim 65 wherein the planar wick is formed of unwoven, fibrous material.
85. The candle of claim 65 wherein the wick is sized relative to the body to correlate the wick's burn rate with the material of the body to thereby provide an even depletion of the meltable fuel.
86. The candle of claim 65 wherein the wick comprises wood.
87. The candle of claim 65 wherein the meltable fuel is a mixture of paraffin and a vegetable-based wax.
88. The candle of claim 65 wherein the meltable fuel includes at least one of stearic acids, UV inhibitors, polyethylene, scent oils, and color pigments.
89. The candle of claim 65 wherein the body has a diameter of approximately one to six inches and the wick has a width of 1/8 to two inches.
90. The candle of claim 65 wherein the body has a diameter of approximately six to twelve inches and the wick has a width of 1/8 – six inches.

91. The candle of claim 90 wherein the number of the wicks in the candle is between one and twelve.
92. The candle of claim 65 wherein the body has a diameter of approximately twelve to twenty-four inches and the wick has a width of 1/8 - twenty inches.
93. The candle of claim 92 wherein the number of wicks in the candle is between one and twenty.
94. The candle of claim 65 wherein the planar wick comprises two sheets of wood with a flat piece of cotton sandwiched there between.
95. The candle of claim 65 wherein the planar wick comprises pressed wood with bits of fiber and adhesive in the pressed wood.
96. The candle of wick of claim 95 wherein the fibers are cellulose materials, cotton, hemp, rayon, linen, paper and /or flax.
97. The candle of claim 95 wherein the adhesive is resin, gum, or natural glue.
98. The candle of claim 65 wherein the exterior of the wick is sealed with wax.
99. The candle of claim 65 wherein the wick is largely of cellulose and lignin.
100. The candle of claim 65 wherein the wick comprises wood particles and gum.
101. The candle of claim 65 wherein the wood of the wick is selected from a group consisting of poplar, cherry, maple, wenge, oak, rosewood, and bamboo.
102. The candle of claim 65 wherein the wick is made of wood combined with cotton.

103. The candle of claim 65 wherein the wick is made of wood bonded with natural adhesives or resins.

104. The candle of claim 65 wherein the wick is made from trees or shrubs and consists substantially of cellulose and lignin.

105. The candle of claim 65 wherein the wick is made from leaves or bark and consists substantially of cellulose and lignin.

106. The candle of claim 65 wherein the wick has indicia printed on a flat surface thereof.

107. The candle of claim 65 wherein the wick is bleached or dyed.

108. The candle of claim 65 wherein the wick is curved vertically.

109. The candle of claim 65 wherein the wick comprises a rigid, solid sheet material consisting substantially of cellulose and lignin.

110. The candle of claim 65 further comprising a wick holder which holds the wick.

111. The candle of claim 110 wherein the wick holder includes a base and a slotted support for receiving the wick extending from the base.

112. The candle of claim 65 further comprising a container in which the body is disposed.

113. The candle of claim 65 wherein the wick is configured in a decorative shape as viewed from above.

114. The candle of claim 65 wherein the wick has a width greater than  $\frac{1}{4}$  inch, is rigid so as to be capable of being freestanding and is made at least substantially of wood or cellulose/lignin material.

115. A candle comprising:

a body formed of a meltable fuel; and

a planar wick disposed in the body and having an upper end extending beyond an upper surface of the body, wherein the wick is formed essentially of wood selected from a group consisting of poplar, cherry, maple, wenge, oak, rosewood, and bamboo.

116. The candle of claim 115 wherein at least one of the body and the wick includes scented oil.

117. The candle of claim 115 further comprising a wick holder having a base and a support for receiving a bottom end of the wick.

118. The candle of claim 115 wherein the wood has a moisture content of 10-12 percent.

119. A method of making a candle, comprising:

combining a planar wick and a body of meltable fuel such that the planar wick extends beyond an upper surface of the body.

120. The method of claim 119 wherein the combining includes maintaining the wick in a set position and dispensing the meltable fuel about the wick in a non-solid form and allowing the dispensed meltable fuel to solidify.

121. The method of claim 120 wherein the planar wick comprises wood.

122. The method of claim 121 wherein the wood is selected from a group consisting of poplar, cherry, maple, wenge, oak, rosewood, and bamboo.

123. The method of claim 121 wherein the wood has a moisture content of 10-12 percent.

124. The method of claim 119 further comprising setting the wick in a wick holder.

125. A method of making a candle, comprising:

forming a body of meltable fuel having a top surface and a slot engaging the top surface and extending down at least a substantial distance of a height of the body; and

inserting a wick into the slot.

126. The method of claim 125 wherein the wick is an elongate planar wick.

127. The method of claim 125 wherein the wick is rigid so as to be capable of being straight freestanding.

128. The method of claim 125 wherein the wick is made of wood or wood product.

129. The method of claim 125 wherein the forming includes positioning an elongate member so that it extends down into a candle mold in a desired position relative thereto; and dispensing the meltable fuel in a flowable condition into the mold around the elongate member; after the dispensing, allowing the fuel to solidify; and thereafter and before the inserting, removing the elongate member from the solidified fuel.

130. The method of claim 129 wherein the positioning includes positioning a positioning device on the mold and the elongate member extending down from the positioning device.

131. The method of claim 130 wherein the positioning includes positioning the positioning device such that it centers the elongate member relative to the mold.



132. The method of claim 131 wherein the positioning the positioning device includes engaging the positioning device on a rim of the mold.

133. The method of claim 130 wherein the forming includes positioning the elongate member in a held position on the positioning device.

134. The method of claim 125 wherein before the inserting, the wick is coated with wax.

135. The method of claim 125 further comprising after the forming, inserting a wick positioning device having a slot in a bottom of the body.

136. The method of claim 135 further comprising inserting a bottom end of the wick in the slot.

137. A candle making assembly, comprising:  
an elongate member; and  
a positioning device adapted to engage a candle mold so as to position the elongate member so that it extends down into the candle mold in a wick position.

138. The assembly of claim 137 wherein the positioning device includes a holding device for the elongate member and a pair of support arms extending out from the holding device for engaging a top of the candle mold.

139. The assembly of claim 138 wherein the arms include a plurality of spaced recesses for engaging rims of candle molds of different diameters.

140. The assembly of claim 138 wherein the holding device includes a plurality of resilient fingers for holding elongate members of different widths.

141. A wick sustain device, comprising:

a base member; and  
structure extending up from the base member and defining an upwardly-disposed slot having a height of .20 to .40 inch and a width of .25 to 12 inches.

142. The device of claim 141 wherein the height is approximately  $\frac{1}{2}$  inch.

143. The device of claim 141 wherein the width is .07 inch.

144. The device of claim 141 wherein the structure includes a pair of opposing plates defining the slot therebetween.

145. The device of claim 144 wherein one of the plates is approximately .10 inch taller than the others.

146. The device of claim 144 wherein the plates are arcuately shaped.

147. The device of claim 141 wherein the base member comprises a plate.

148. The device of claim 147 wherein the base member is round, square, rectangular or oval.

149. The device of claim 148 wherein the base member has a diameter of  $\frac{1}{2}$  to 12 inches.

150. The device of claim 141 wherein the base member and the structure are formed as a single piece of clear plastic material.

151. A wick holder comprising:

a body having a top surface, a bottom surface, two upper walls connected to the top surface and the bottom surface, and a planar bore adapted to receive a planar wick passing through the two upper walls; and

a barrier extending horizontally through the upper walls.

152. The wick holder of claim 151 wherein the body is made from a polymer and a ceramic.

153. The wick holder of claim 151 wherein the body is made from polyethersulfone.

154. The wick holder of claim 151 wherein the body has a thickness of 1/32 inch.

155. The wick holder of claim 151 wherein the body is non-combustible and intumescent when heated.

156. The wick holder of claim 151 wherein the body is flat, the walls are flat and the barrier is part of the design where the slot/bore stops the wick keeping it from the top of the body.

157. The wick holder of claim 151 wherein the barrier is the raise portion under the wick slot.

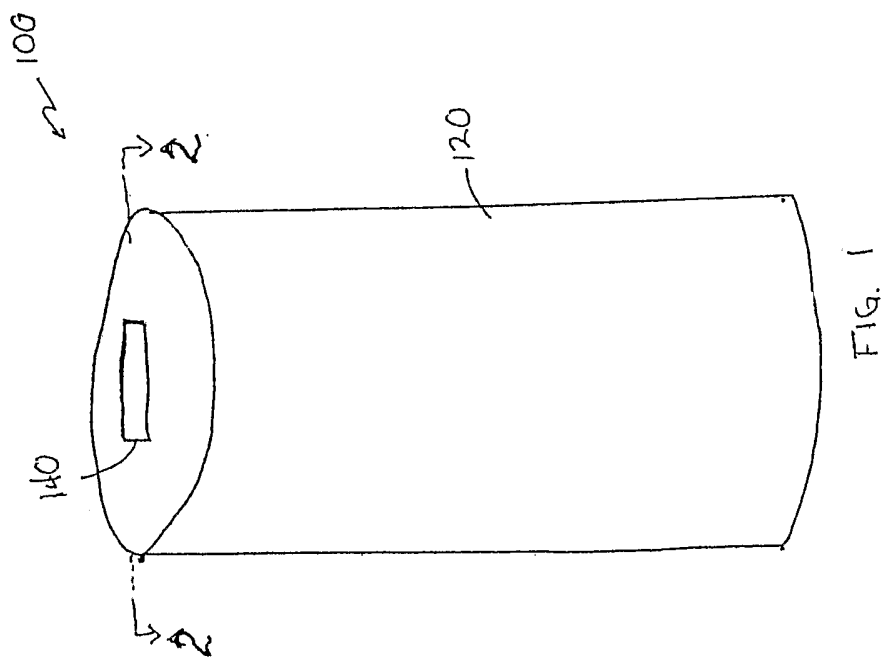
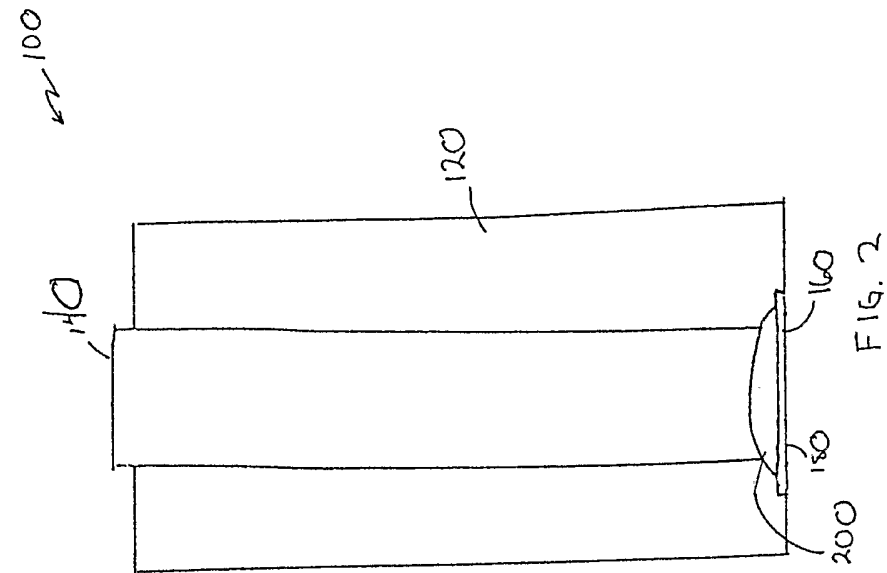

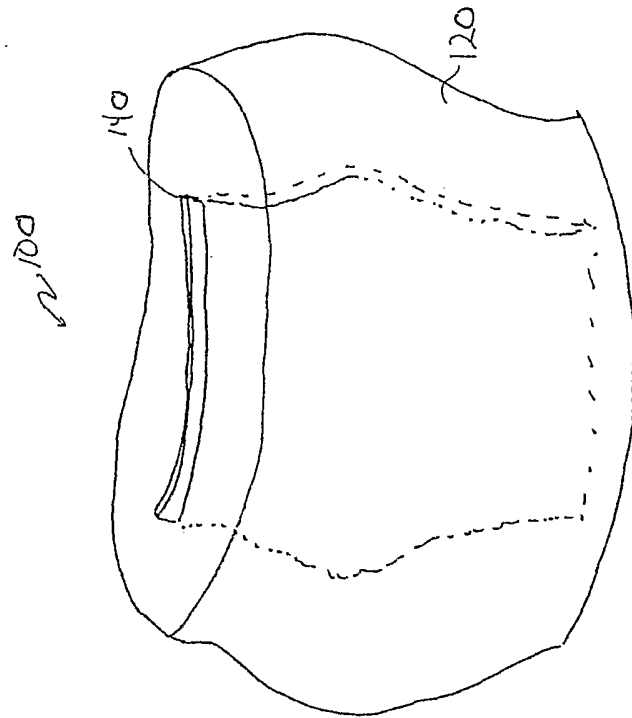
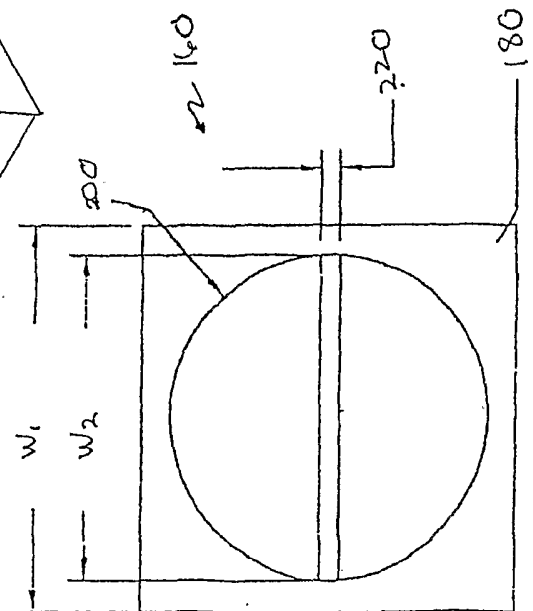
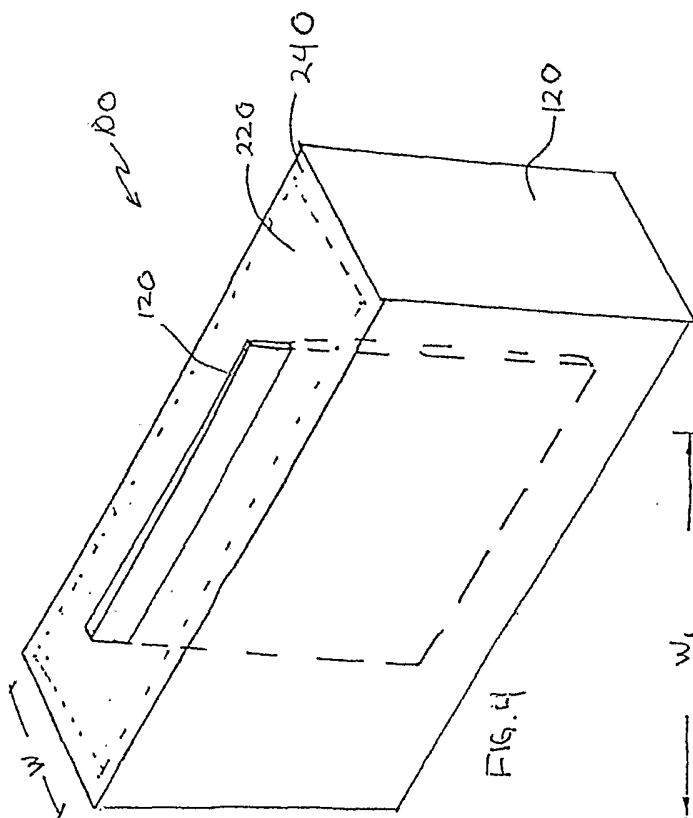

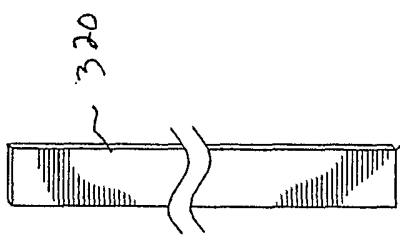
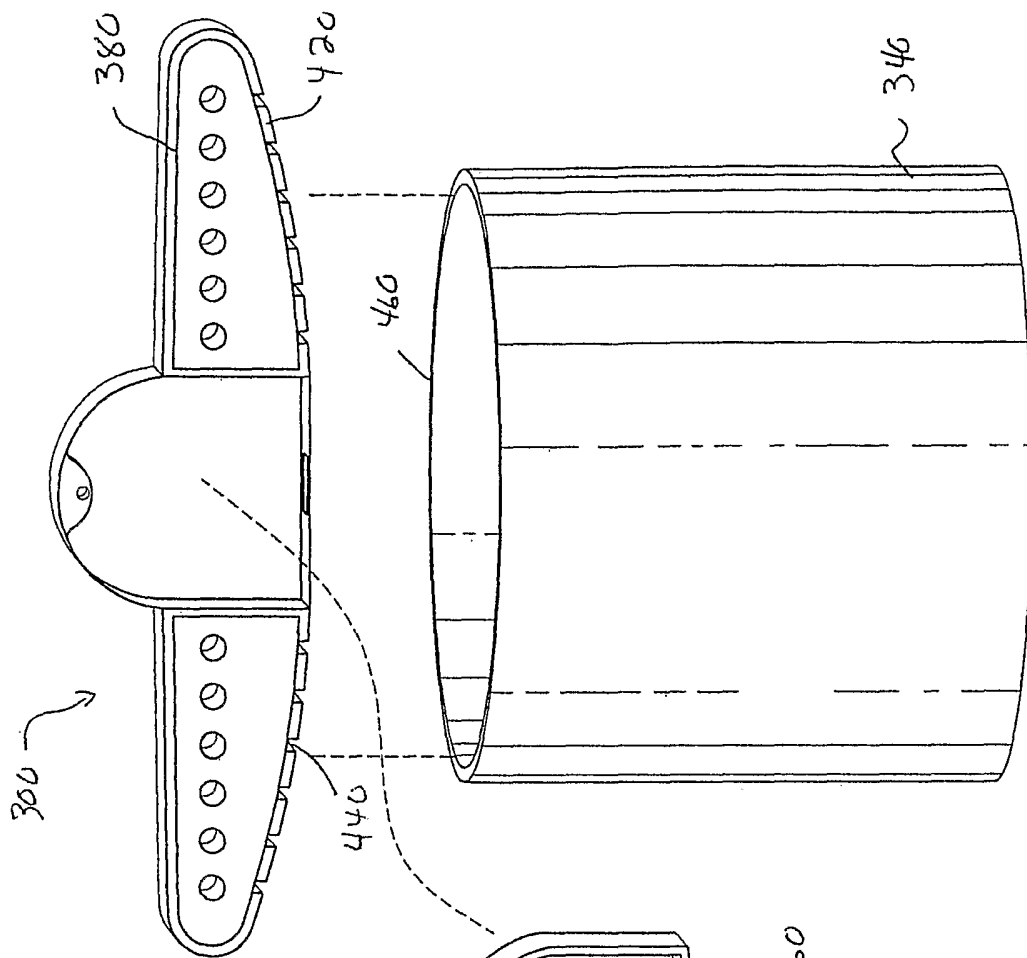

FIG. 6

FIG. 7

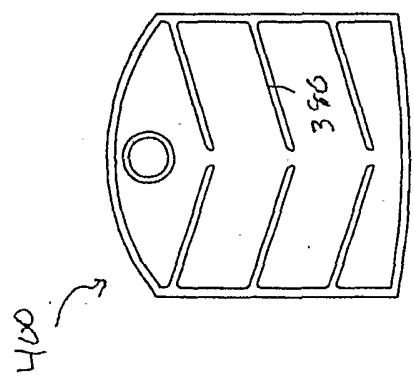
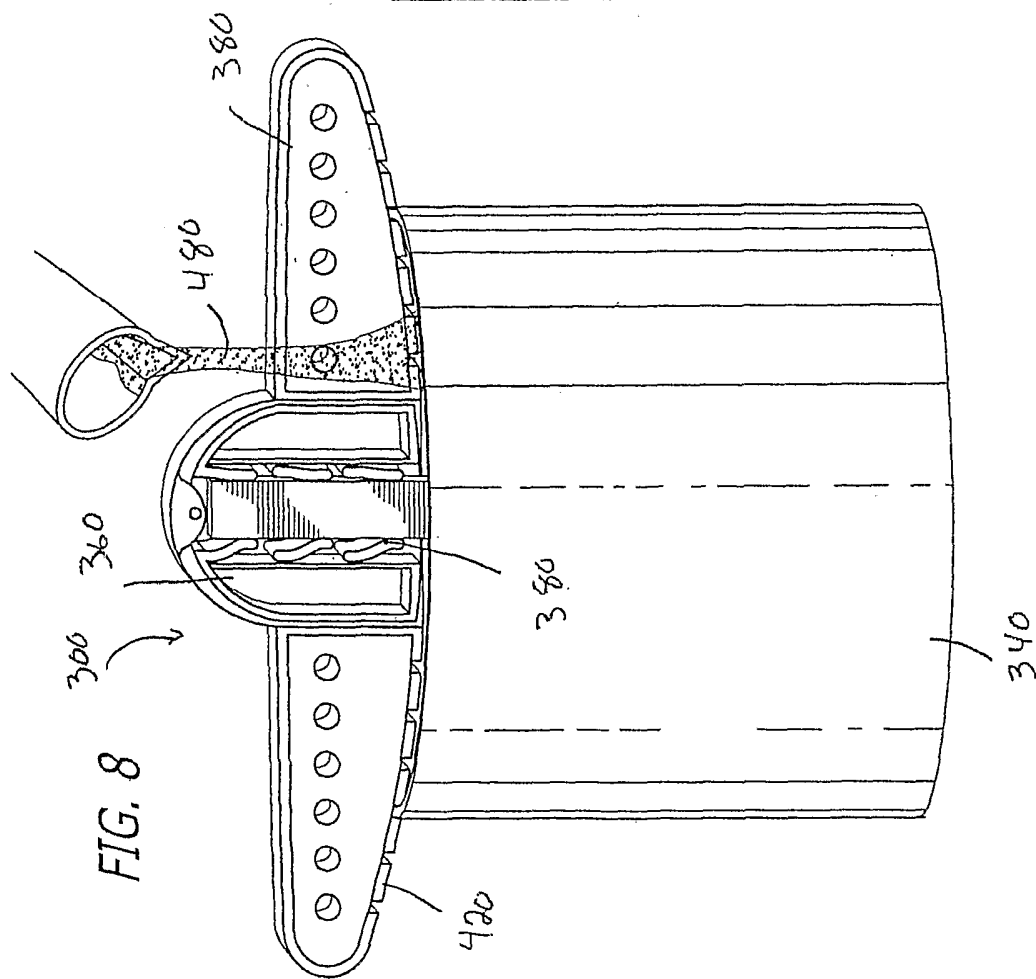
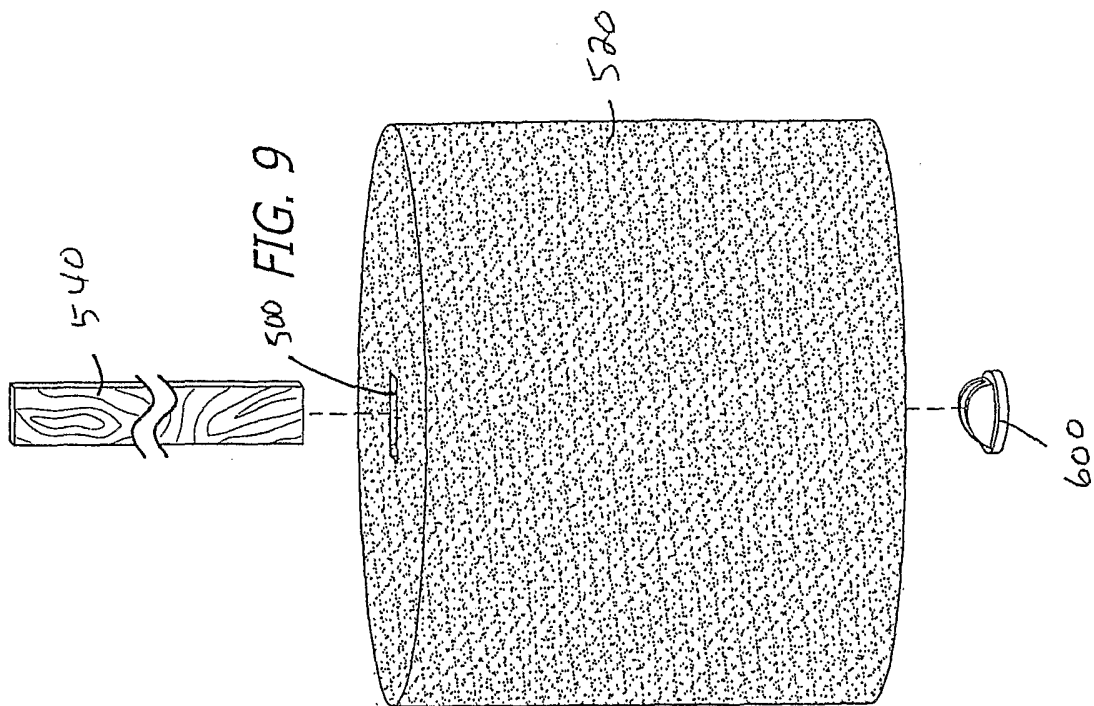

FIG. 8



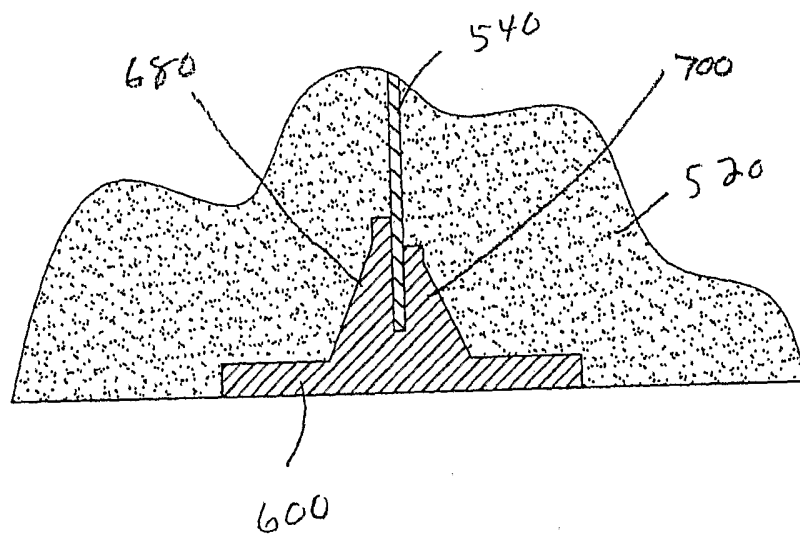

FIG. 10



