

C. W. CHAPPELL.

Improvement in Railroad-Tank Valves.

No. 130,411.

Patented Aug. 13, 1872.

Fig. 1.

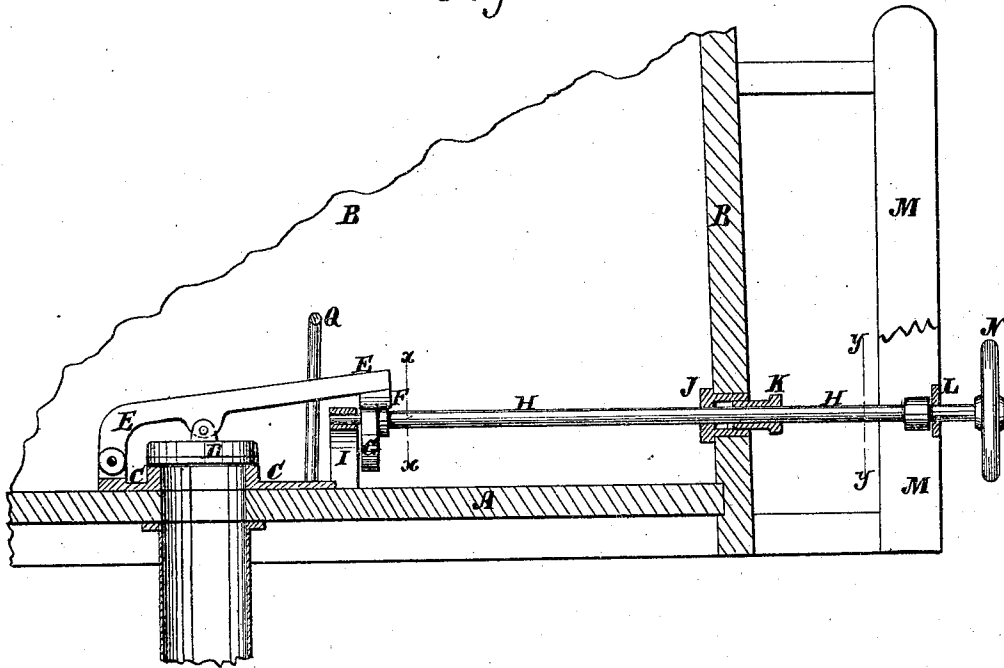
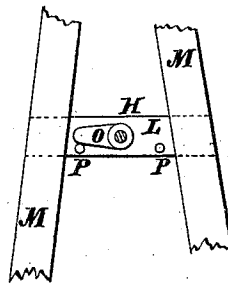

Fig. 2.



Fig. 3.



Witnesses:

A. Bennetendorf.  
W. A. Graham

Inventor:

C. W. Chappell.

PER

Wm. J. L.  
Attorneys.

# UNITED STATES PATENT OFFICE.

CHARLES W. CHAPPELL, OF WATERTOWN, WISCONSIN.

## IMPROVEMENT IN RAILROAD-TANK VALVES.

Specification forming part of Letters Patent No. 130,411, dated August 13, 1872.

Specification describing a new and Improved Device for Operating a Railroad Water-Tank Valve, invented by CHARLES W. CHAPPELL, of Watertown, in the county of Jefferson and State of Wisconsin.

Figure 1 is a detail side view of my improved device, shown as applied to a water-tank. Fig. 2 is a detail sectional view of the same taken through the line *x x*, Fig. 1, and showing the eccentric-wheel and end of the valve-lever. Fig. 3 is a detail sectional view of the same taken through the line *y y*, Fig. 1, and showing the device for stopping the shaft when the valve has been opened or closed.

Similar letters of reference indicate corresponding parts.

My invention has for its object to furnish an improved device for operating a railroad water-tank valve, which shall be simple in construction, reliable and effective in operation, neat in appearance, durable and convenient in use, enabling the valve to be conveniently opened whatever may be the weight of the water pressing upon the valve; and it consists in the construction and combination of the various parts of the device, as hereinafter more fully described.

A represents the bottom, and B the side, of a water-tank. C is the valve-seat plate, which is attached to the inner side of the bottom A of the tank, and which has a hole formed in it corresponding with the discharge-hole in the bottom of the tank. D is the valve, which fits down upon the valve-seat C and closes the discharge-opening. The valve D is pivoted to the lever E, the end of which is pivoted to a lug or lugs attached to or formed upon the plate C. Upon the under side of the free end of the lever E is formed or to it is attached a block or plate, F, concaved upon its lower side to fit and ride upon the eccentric-

wheel G attached to the shaft H, the inner end of which is pivoted to the bracket I, attached to the bottom of the tank. The shaft H passes out through a stuffing-box, J, and gland K, secured in a hole in the side of the tank, so that the shaft H may pass out through the side of the tank without leakage. The outer part of the shaft H revolves in bearings in a bar, L, attached to the gallows M that support the water-spout. To the outer end of the shaft H is attached the hand-wheel N, by which said shaft is operated. To the shaft H, at the side of the bar L, is attached an arm, O, which, when the shaft is revolved into position to open and close the valve D, strikes against stop-pins P, attached to the bar L, as shown in Fig. 3. By this arrangement, by turning the shaft H the eccentric-wheel G, operating upon the concaved block or plate F attached to the lever E, raises the said lever and opens the valve D. When sufficient water has been drawn off the shaft H is started in the other direction, and the valve D is immediately closed and held by the pressure of the water.

The lever E is made to move up and down in a vertical plane by a loop or staple, Q, attached to the bottom of the tank, as shown in Fig. 1.

Having thus described my invention, I claim as new and desire to secure by Letters Patent—

The water-tank, having apertured bottom A provided with valve-seat C, in combination with a valve, D, pivoted to a lever, E, operated by an eccentric, G, at right angles thereto, as and for the purpose set forth.

CHARLES W. CHAPPELL.

Witnesses:

C. B. SKINNER,  
CALVIN CHENEY.