

Oct. 27, 1936.

J. WEBER

2,058,745

RECEPTACLE

Filed June 19, 1934

2 Sheets-Sheet 1

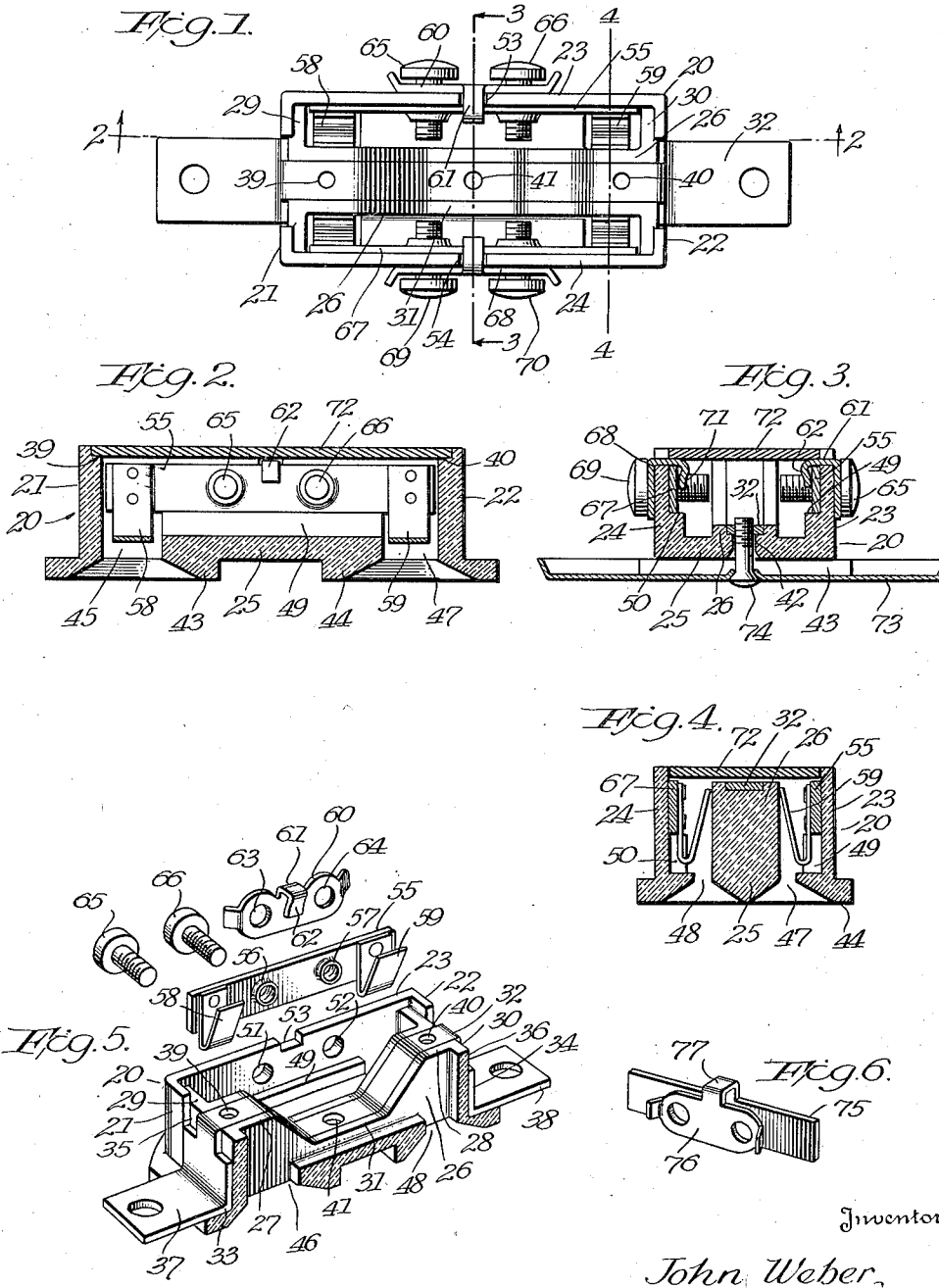

Inventor

John Weber,

By *Herbert W. Dwyer, Arthur*
Attorneys

Oct. 27, 1936.

J. WEBER

2,058,745

RECEPTACLE

Filed June 19, 1934

2 Sheets-Sheet 2

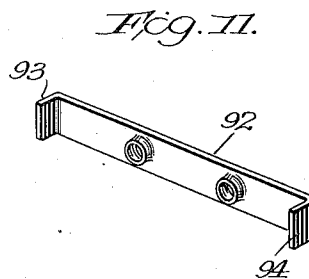
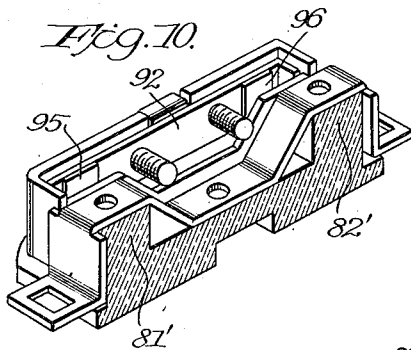
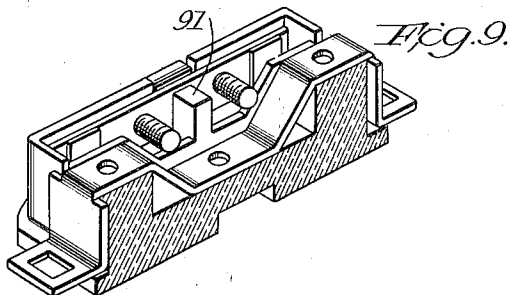
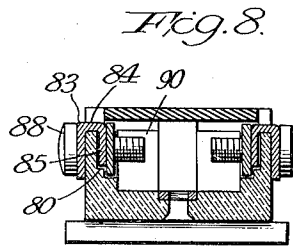
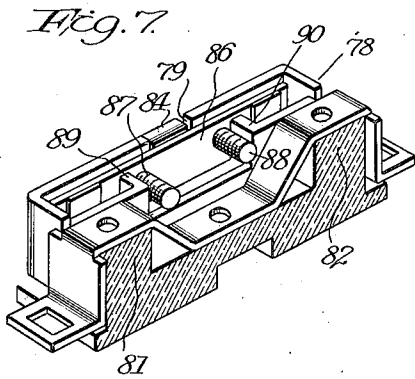

Inventor

John Weber.

By *Cummins, Wiley & Russell*
Attorneys

UNITED STATES PATENT OFFICE

2,058,745

RECEPTACLE

John Weber, Schenectady, N. Y., assignor to
Alpine Electric Corporation, Schenectady,
N. Y., a corporation of New York

Application June 19, 1934, Serial No. 731,371

9 Claims. (Cl. 173—330)

The present invention relates to outlet receptacles and presents a number of features affording ease of manufacture, compactness, and efficiency.

5 In the accompanying drawings, I have shown several practical embodiments of the invention, the invention in each case being embodied in a duplex receptacle merely as a matter of illustration and without restrictive intent. Since the
10 invention will be best understood from a description of these specific embodiments, I shall proceed to describe it with reference to the drawings.

In the drawings,

15 Figure 1 is a rear plan view of one embodiment of the invention with a cover plate removed to reveal the internal arrangement;

Figure 2 is a section substantially on line 2—2 of Figure 1;

20 Figure 3 is a section substantially on line 3—3 of Figure 1;

Figure 4 is a section substantially on line 4—4 of Figure 1;

25 Figure 5 is a perspective, partly in section, of the embodiment in Figure 1 with parts in disassembled relation;

Figure 6 shows in perspective a bus bar of modified form as regards the bus bars shown in Figures 1 to 5;

30 Figure 7 is a perspective of a modified form which the invention may take;

Figure 8 is a central transverse section of the receptacle of Figure 7;

35 Figure 9 is a perspective showing a variation of the arrangement as in Figure 7;

Figure 10 is a perspective showing a further variation of the arrangement as in Figure 7; and

40 Figure 11 is a perspective of a detail appearing in Figure 10.

Referring to the drawings and first to Figures 1 to 5, reference numeral 20 designates generally a body of any suitable insulating material. As here shown, the body 20 has parallel end walls 21 and 22, parallel side walls 23 and 24, and a front wall 25, these walls defining a cavity adapted to receive certain mechanisms which will be hereinafter described. A rib 26 extends longitudinally and medially of the cavity and at its ends has portions 27 and 28 whose top surfaces lie in a plane common to inner shoulders 29 and 30 formed in the end walls 21 and 22, respectively, these shoulders lying somewhat below the upper edges of said end walls and the upper edges of the latter, as here shown, being in the plane of the upper edges of the side walls 23 and 24. Centrally, rib
55 26 is downwardly offset to provide a flat portion

31 at the rear of the front face 25 and the entire rib is longitudinally grooved to receive in close fitting and preferably flush relation a complementarily conformed anchor strap 32. The anchor strap has angular end portions 33 and 34
5 received, as here shown, in flush relation in grooves 35 and 36 on the outer sides of the end walls 21 and 22, the anchor straps terminating in outwardly bent perforated portions 37 and 38 partially received in angular continuations of grooves
10 35 and 36. Inwardly of the end walls, the anchor strap is provided with apertures 39 and 40 through which screws are adapted to be passed to be engaged, as in a threaded insert, in the underlying rib. Centrally, the anchor strap is provided with
15 an aperture 41 which registers with an aperture 42, Figure 3, formed in the front wall 25.

At its ends, front wall 25 has formed thereon a pair of bosses 43 and 44 provided with service openings 45, 46, and 47, 48, Figures 2, 4, and 5,
20 adapted to pass the contact fingers of the usual connector plugs. The openings 45, 46 and 47, 48 communicate respectively with the recesses at the left and right ends of the body cavity between the side walls and central rib. The side walls are provided at their base portions with internal
25 rectilinearly extending shoulders 49 and 50 which terminate longitudinally adjacent the service openings as indicated in Figures 2 and 5.

Slightly above shoulders 49 and 50, each side wall is provided medially and opposite the downward offset of rib 26 with longitudinally spaced
30 apertures as at 51 and 52, Figure 5, and the upper edges of the side walls between these apertures are provided with shallow notches 53 and 54.

A bus bar 55, preferably formed of a flat metal strip, is flatly disposed against the interior surface of wall 23 and is provided with threaded apertures 56 and 57 which register with apertures 51 and 52, respectively, when the lower edge of the bus bar rests on shoulder 49. At its ends, the bus bar has secured thereto or formed therewith spring contacts 58 and 59, here shown as U-shaped, whose free portions are in position to be engaged by plug fingers passed through the service openings, the extremities of the free portions normally bearing against the adjacent sides of the central rib 26, the rib being of a thickness substantially equal to the distance between the service openings. A contact plate 60 is positioned against the exterior surface of wall 23 and has centrally an upward extension 61 which is bent to extend across the top of wall 23 in notch 53 and downwardly to provide a finger 62 which lies behind bus bar 55. Contact plate 60 is pro-
55

vided with apertures 63 and 64 which register with apertures 51, 56 and 52, 57, respectively, and through the aligned apertures are passed terminal screws 65 and 66, the inner ends of these screws engaging the threads in the bus bar apertures 56 and 57, the depression in rib 26 providing clearance for the inner ends of the screws.

An exactly similar bus bar 67 and contact plate 68 are mounted on wall 24 in the same manner as above described and engaged by terminal screws 69 and 70, the contact plate 68 having an extension bent into notch 54 and downwardly to provide an extremity 71 engaged behind bus bar 67, Figure 3.

The body cavity is closed by a cover plate 72 of insulating material whose ends are supported on shoulders 29 and 30, the plate being provided with apertures, not shown, receiving screws, not shown, which are engaged with the body through apertures 39 and 40 in the anchor strap to hold the cover plate, anchor strap, and body 20 together. It will also be noted from Figure 3 that the sides of cover plate 72 overlie the inwardly extending portions of the contact plate extensions. To complete the assembly, a face plate 73 is secured in position by means of a screw 74 passing through aperture 42, Figure 3, and engaged in the central threaded aperture of the anchor strap, the screw 74 being of relatively short length, due to the proximity of the engaged portion of the anchor strap to the front face and being readily threaded to position due to the steady positioning of the anchor strap in the groove in which it lies.

In assembly, the bus bars are first placed in position on the shoulders 49 and 50. The bus bars are preferably of a length substantially equal to the distance between the end walls of the cavity which, in conjunction with the ribs, immediately position the bus bars with their apertures in alignment with the side wall apertures. Hereupon, the contact plates, whose extensions are preferably preformed, are slipped in position so that their depending fingers take the position most clearly shown in Figure 3. The notches 53 and 54 serve to position the contact plates longitudinally of the side walls and the depth of the notches is such that when the transverse portions of the extensions are fully seated therein, the apertures of the contact plates are in alignment with the apertures in the associated side walls and bus bars. Upon the positioning of the contact plates, the terminal screws are screwed into position, fingers 62 and 71 receiving the thrust so that the bus bars are not distorted.

Preferably, fingers 62 and 71 are so formed and are sufficiently springy that even when the terminal screws are tightly screwed home, the fingers are still in conductive engagement with the bus bars, as shown in Figure 3, so that they constitute electrical connections between the contact plates and bus bars in addition to the terminal screws. This office of fingers 62 and 71, however, may be dispensed with, if desired, and they may merely serve as abutment means which are out of contact with the bus bars when the screws are tightly engaged. In some cases, the contact plates or their extensions, and consequently notches 53 and 54, may be dispensed with, but in such case, other abutment means for the bus bars should preferably be provided. However, I prefer to use the contact plates in the form shown in view of their several advantages as above discussed. When the conductors

are engaged under the heads of the screws and the latter are tightly engaged in position with the contact plates and bus bars clamped against the side walls, an extremely rigid structure is presented which will withstand the stresses encountered when the receptacle is pushed into position in the wall box. This rigid construction prevents dislocation of the contacts even when a relatively heavy conductor is used.

It will be noted from Figure 3 that since the sides of the cover plate overlie the portions of the contact plate extensions which traverse the side walls, the contact plates and bus bars will be retained in position even in the event of removal of all the terminal screws.

In Figure 6, there is shown a bus bar 75 integrally connected with a contact plate 76 by means of a strip or extension portion 77, the contact plate and bus bar being spaced apart substantially the thickness of the body side wall, Figures 1 to 5, and the portion 77 being engageable in a side wall notch. The contact plate 76 is provided with apertures adapted to freely pass contact screws and the bus bar is provided with threaded apertures in alignment with the contact plate apertures. The bus bar may have the same contact provisions as described with reference to bus bar 55 above. This bus bar and contact plate unit may be substituted for the separate bus bars and contact plates, above described, in a manner which will be perfectly understood. Portion 77 has the functions of the contact plate extensions, previously discussed and, of course, always provides a conductive path between the contact plate and bus bar.

Referring to Figure 7, the body of insulating material generally designated at 78 is generally similar to body 20. Each side wall is provided with a notch as at 79 which, on the inner side of the wall, is joined by or continued into a vertical groove 80. The central rib is abruptly downwardly offset and provides in effect two end blocks 81 and 82. A contact plate 83 has an extension bent to provide a horizontal portion 84 and a downwardly extending finger 85, portion 84 lying in the notch 79 and portion 85 in the groove 80 and the effective length of portion 84 being substantially the thickness of the side wall between its exterior surface and groove 80. The bus bar 86 may be exactly the same as the bus bar 55, heretofore described, and the side wall and contact plate are perforated as in the first embodiment to receive the terminal screws 87 and 88. When these screws are tightened, the bus bar is drawn against finger 85 to provide a conductive path between plate 83 and the bus bar other than the paths provided by the screws. Preferably, groove 80 extends in the side wall a depth less than the thickness of finger 85 so that the latter cannot come into flush or sunken relation with respect to the inner side wall faces, contact between the finger and the bus bar being thus assured.

Since, in this embodiment, the finger 85 is ineffective to receive the thrust of the terminal screws, I preferably continue the sides of blocks 81 and 82 inwardly to vertical edges and then turn them outwardly substantially into contact with the bus bars immediately outwardly of screws 87 and 88, thus forming abutments as at 89 and 90 adapted to receive the thrust of the screws.

The construction shown in Figure 9 is exactly the same as that of Figures 7 and 8, with the exception that abutment lugs as at 91 are provided

adjacent the side walls intermediate the screws to take the thrust of the latter.

In Figure 10, the insulating body is the same as in Figures 7 to 9 with the exception that it provides no abutment means to take the thrust of the screws. The bus bars, as at 92, however, have returned ends as at 93 and 94 whose extremities are adapted to abut the sides of the end blocks or rib portions 81' and 82' to hold the main body of the bus bars against the inner surfaces of the side walls. The bus bars 92 may have spring contacts 95 and 96 exactly the same as the contacts 58 and 59, hereinbefore described, these being positioned somewhat inwardly of the ends 93 and 94, whose outer surfaces are substantially against the inner surfaces of the body end walls when the bus bar is in position.

From the above description, it will be seen that the invention may be variously embodied. Other changes in form and arrangement may be made without departure from the scope of the invention as defined in the following claims.

I claim:—

1. A receptacle comprising a hollow body of insulating material, said body having end and side walls and a front wall, bus bars in the body cavity arranged against the side walls, the side walls having apertures therein and the bus bars having threaded apertures aligned with the wall apertures, terminal screws passed through the wall apertures and threaded in the bus bar apertures to hold the bus bars against said side walls, said bus bars having portions in hooked engagement with the side walls for taking the thrust of said screws when the latter are inserted, and a cover plate for the rear of said body, said front wall being provided with service openings.

2. A receptacle comprising a hollow body of insulating material, said body having end and side walls and a front wall, bus bars in the body cavity arranged against the side walls, the side walls having apertures therein and the bus bars having threaded apertures aligned with the wall apertures, apertured contact plates arranged against the outer sides of said side walls, terminal screws passed through the apertures of said plates and of the side walls and threaded in the bus bar apertures to hold the associated plates and bus bars against the intervening side walls, said plates having portions traversing said side walls and hooked behind the bus bars to brace the latter against the thrust of said screws, and a cover plate for the rear of said body, said front wall being provided with service openings.

3. A receptacle comprising a hollow body of insulating material, said body having end and side walls and a front wall, bus bars in the body cavity arranged against the side walls, the side walls having apertures therein and the bus bars having threaded apertures aligned with the wall apertures, apertured contact plates arranged against the outer sides of said side walls, terminal screws passed through the apertures of said plates and of the side walls and threaded in the bus bar apertures to hold the associated plates and bus bars against the intervening side walls, means integrally connecting the associated plates and bars over the rear edges of said side walls, and a cover plate for the rear of said body, said front wall being provided with service openings.

4. A receptacle comprising a hollow body of insulating material, said body having end and side walls and a front wall, bus bars in the body cavity arranged against the side walls, the side walls

having apertures therein and the bus bars having threaded apertures aligned with the wall apertures, apertured contact plates arranged against the outer sides of said side walls, terminal screws passed through the apertures of said plates and of the side walls and threaded in the bus bar apertures to hold the associated plates and bus bars against the intervening side walls, means integrally connecting the associated plates and bars over the rear edges of said side walls, the latter being provided with notches receiving said means and a cover plate for the rear of said body, said front wall being provided with service openings.

5. A receptacle comprising a hollow body of insulating material, said body having end and side walls and a front wall, bus bars in the body cavity arranged against the side walls, the side walls having apertures therein and the bus bars having threaded apertures aligned with the wall apertures, apertured contact plates arranged against the outer sides of said side walls, terminal screws passed through the apertures of said plates and of the side walls and threaded in the bus bar apertures to hold the associated plates and bus bars against the intervening side walls, said plates having portions passing over the rear edges of said side walls and hooked behind the bus bars to brace the latter against the thrust of said screws, and a cover plate for the rear of said body, said front wall being provided with service openings.

6. A receptacle comprising a hollow body of insulating material, said body having end and side walls and a front wall, bus bars in the body cavity arranged against the side walls, the side walls having apertures therein and the bus bars having threaded apertures aligned with the wall apertures, apertured contact plates arranged against the outer sides of said side walls, terminal screws passed through the apertures of said plates and of the side walls and threaded in the bus bar apertures to hold the associated plates and bus bars against the intervening side walls, said plates having portions passing over the rear edges of said side walls and hooked behind the bus bars to brace the latter against the thrust of said screws, said rear edges being provided with notches receiving said portions, and a cover plate for the rear of said body, said front wall being provided with service openings.

7. A receptacle comprising a hollow body of insulating material, said body having end and side walls and a front wall, bus bars in the body cavity arranged against the side walls, the side walls having apertures therein and the bus bars having threaded apertures aligned with the wall apertures, apertured contact plates arranged against the outer sides of said side walls, terminal screws passed through the apertures of said plates and of the side walls and threaded in the bus bar apertures to hold the associated plates and bus bars against the intervening side walls, said plates having portions passing over the rear edges of said side walls and hooked behind the bus bars to brace the latter against the thrust of said screws, said rear edges being provided with notches receiving said portions, and a cover plate for the rear of said body, said cover plate overlying said portions at least in part so as to hold the same in position when said screws are removed, said front wall being provided with service openings.

8. A receptacle comprising a hollow body of insulating material, said body having end and

side walls and a front wall, bus bars in the body cavity arranged against the side walls, the side walls having apertures therein and the bus bars having threaded apertures aligned with the wall apertures, apertured contact plates arranged against the outer sides of said side walls, terminal screws passed through the apertures of said plates and of the side walls and threaded in the bus bar apertures to hold the associated plates and bus bars against the intervening side walls, said plates having bent portions hooked over the rear edges of the side walls and positioned between the side walls and the bus bars in contact with the bus bars, and a cover plate for the rear of said body, said front wall being provided with service openings.

9. A receptacle comprising a hollow body of

insulating material, said body having end and side walls and a front wall, bus bars in the body cavity arranged against the side walls, said bus bars having contact fingers at their inner ends bent away from the body side walls, contact screws passed through the body side walls and engaged in threaded apertures of the bus bars, said screws holding the bus bars firmly against said side walls, said bus bars having portions in hooked engagement with the side walls for taking the thrust of said screws when the latter are inserted, the body front wall being provided with service openings which are inwardly of the bus bar ends, said side walls backing the ends of the bus bars to prevent deflection of the latter in use, and a cover plate for the rear of said body.

JOHN WEBER.