



US 20050024825A1

(19) **United States**

(12) **Patent Application Publication**
Smith et al.

(10) **Pub. No.: US 2005/0024825 A1**

(43) **Pub. Date: Feb. 3, 2005**

(54) **RACK MOUNTABLE COMPUTER
COMPONENT FAN COOLING
ARRANGEMENT AND METHOD**

(76) Inventors: **John V. Smith**, Poway, CA (US);
Victor P. Hester, El Cajon, CA (US);
William A. Wylie, San Diego, CA (US)

Correspondence Address:
DUCKOR SPRADLING METZGER
401 WEST A STREET, SUITE 2400
SAN DIEGO, CA 92101-7915 (US)

(21) Appl. No.: **10/928,577**

(22) Filed: **Aug. 27, 2004**

Related U.S. Application Data

(62) Division of application No. 10/449,608, filed on May 29, 2003, now Pat. No. 6,801,428.

(60) Provisional application No. 60/384,996, filed on May 31, 2002. Provisional application No. 60/384,987, filed on May 31, 2002. Provisional application No. 60/384,986, filed on May 31, 2002. Provisional application No. 60/385,005, filed on May 31, 2002.

Publication Classification

(51) **Int. Cl.⁷ G06F 1/20**
(52) **U.S. Cl. 361/687**

(57) **ABSTRACT**

According to certain embodiments of the invention, there is provided an arrangement for cooling a series of closely spaced upright computer components mounted to a support, the arrangement including a tray having a plurality of air moving devices such as fans. Members are used for helping mount removably the tray to the support in a generally horizontal disposition, and the air moving devices move air in a generally upright path of travel to help cool the upright computer components. The tray also has a series of connector ports for connecting electrically to outputs from individual ones of the computer components.

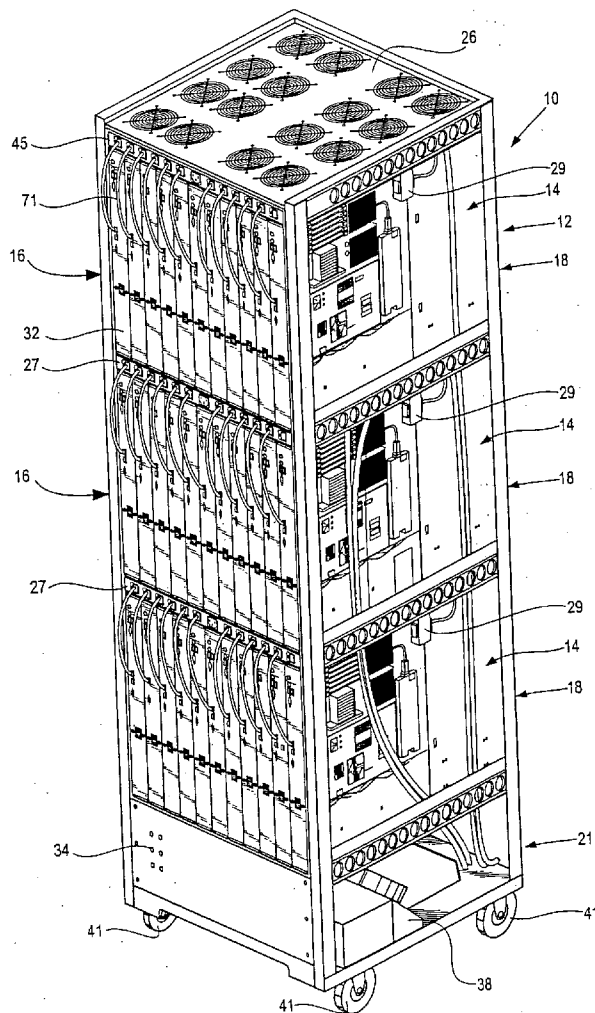

FIG. 1

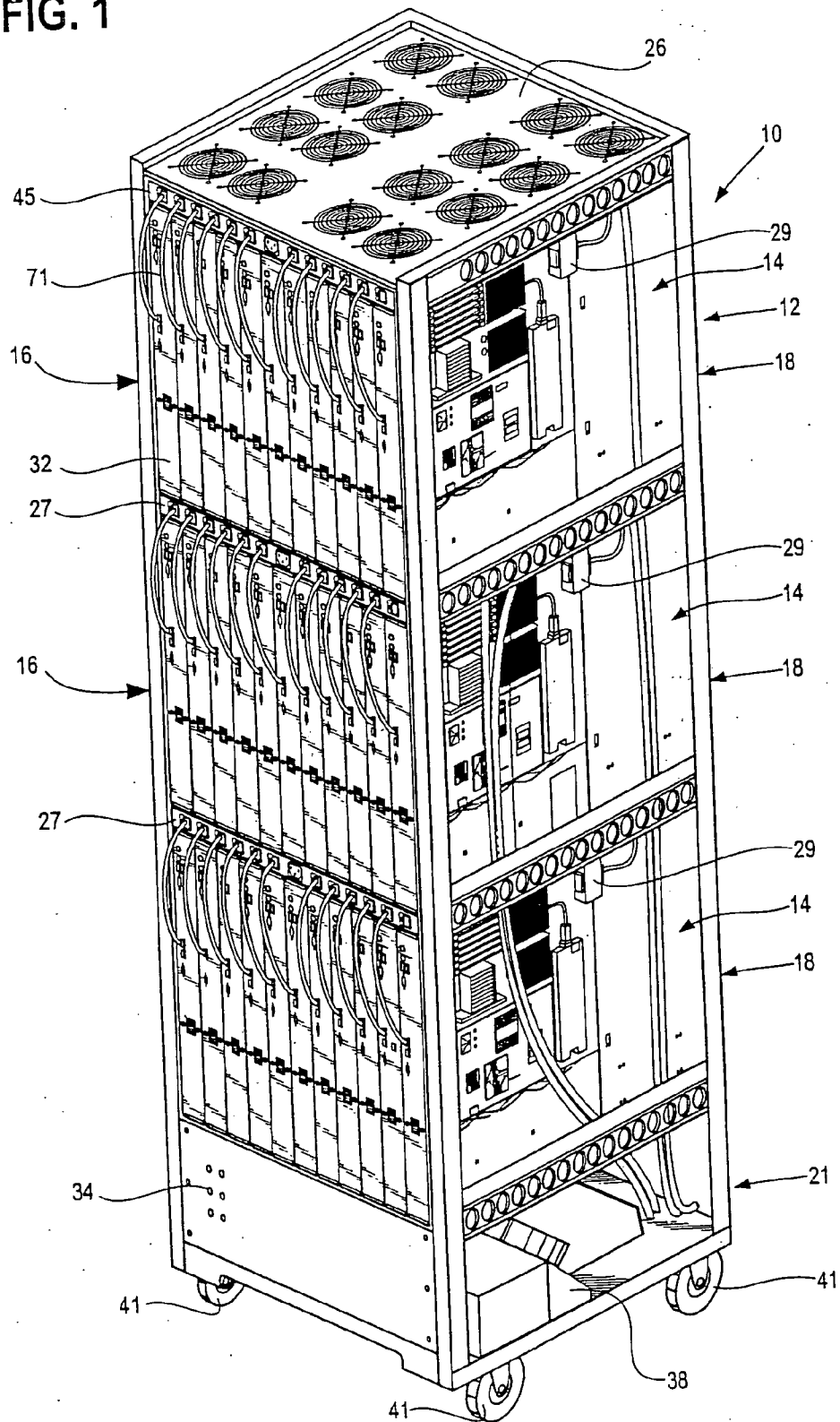

FIG. 2

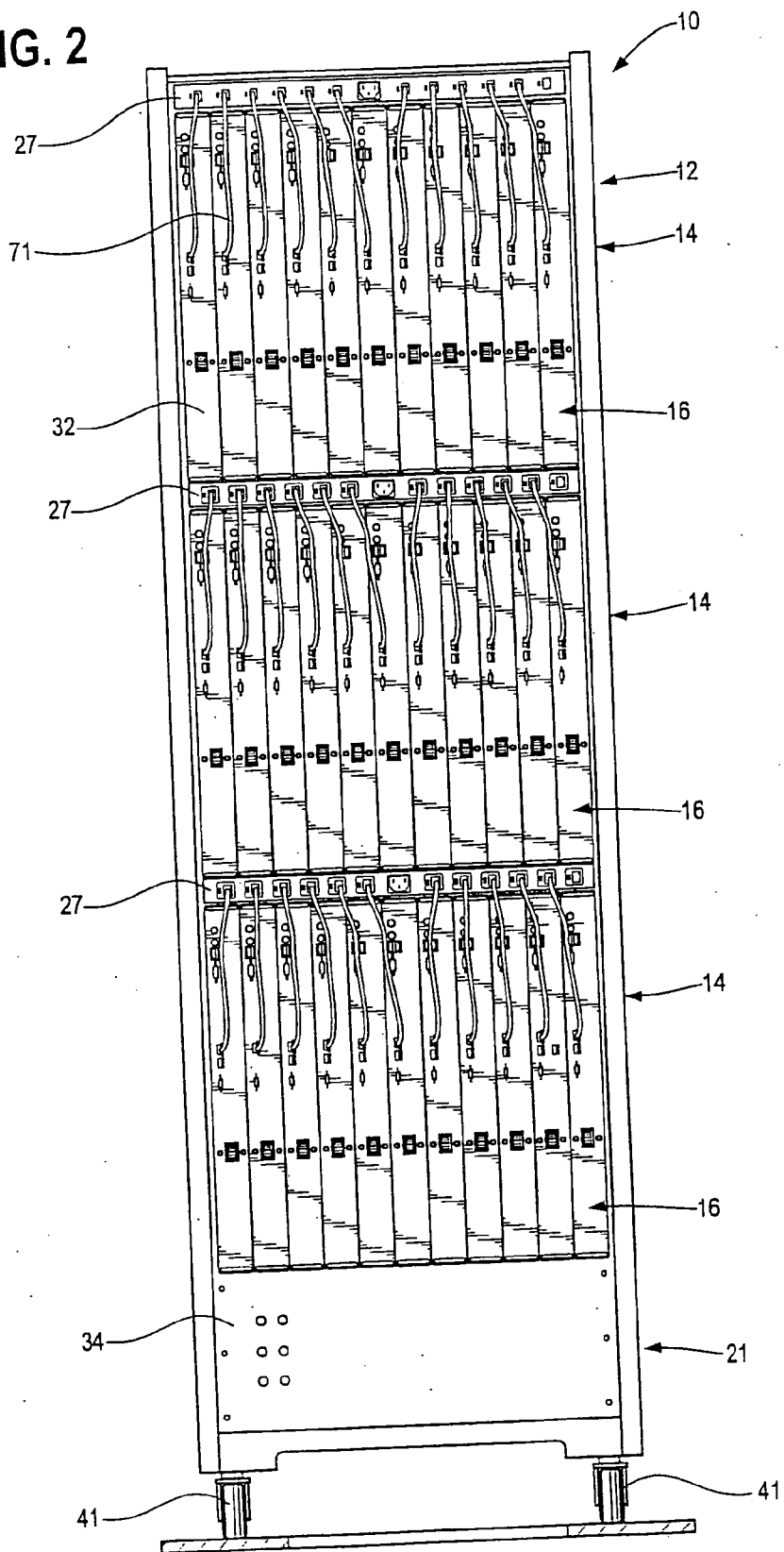

FIG. 3

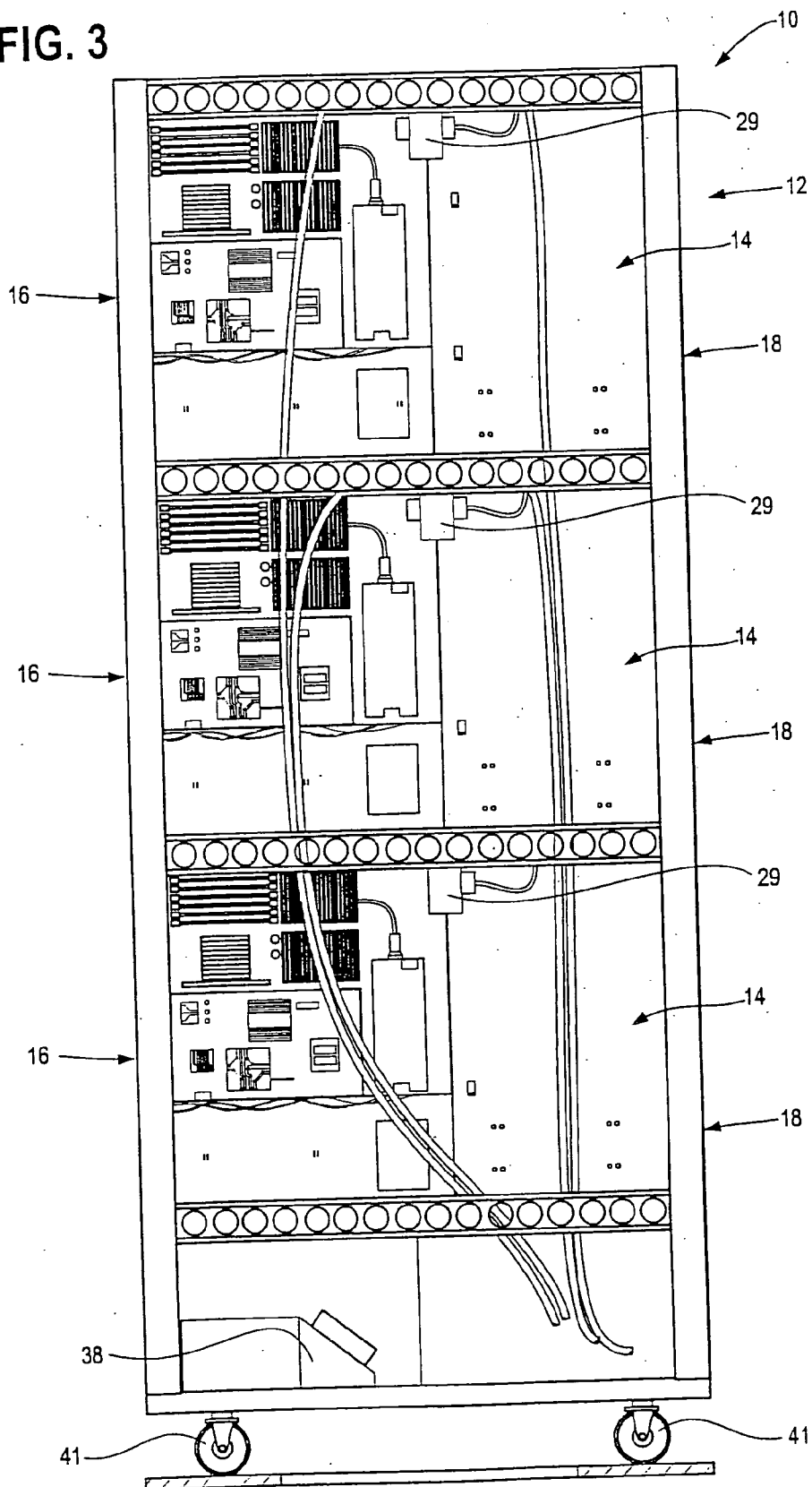

FIG. 4

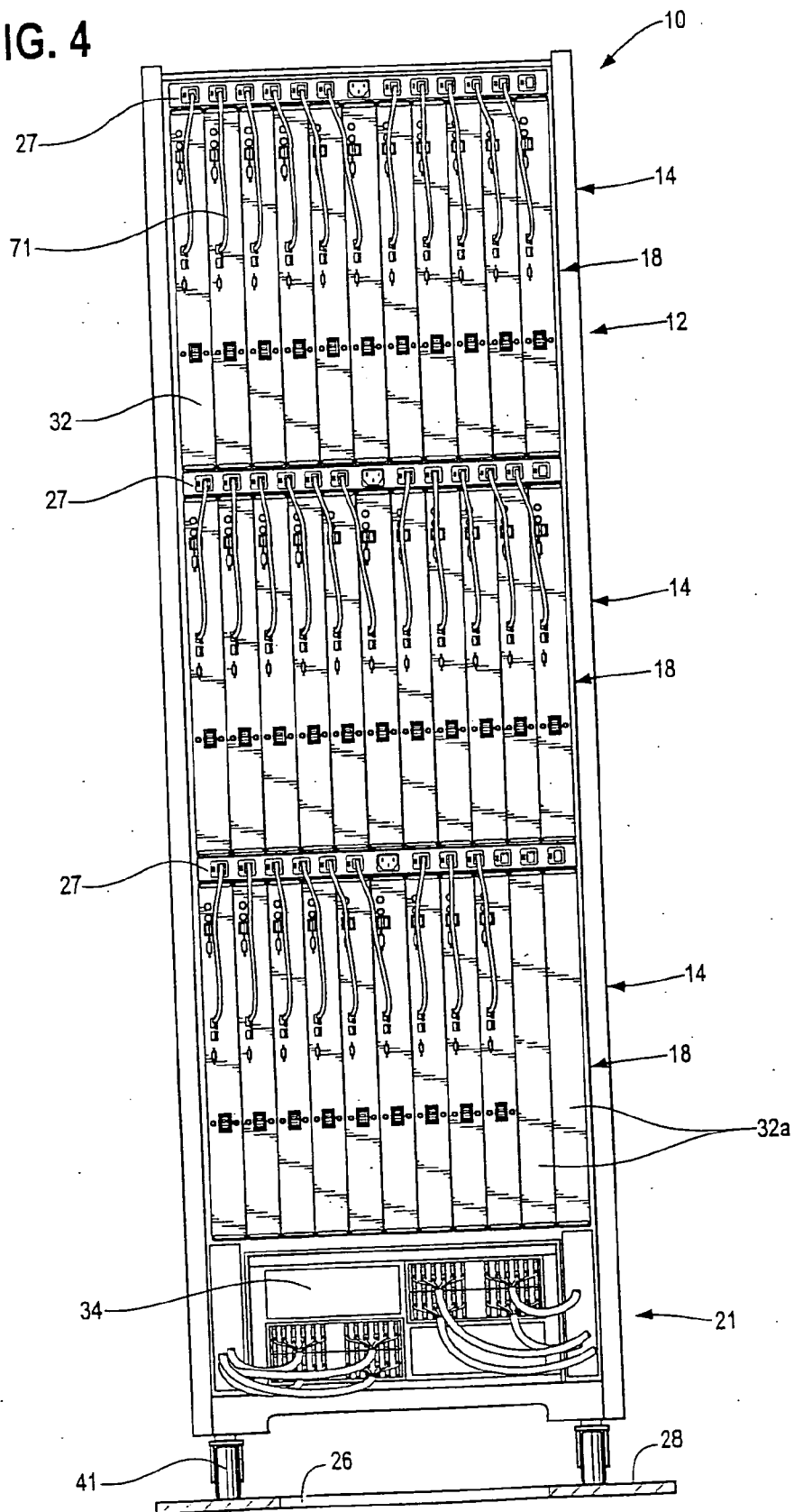

FIG. 5

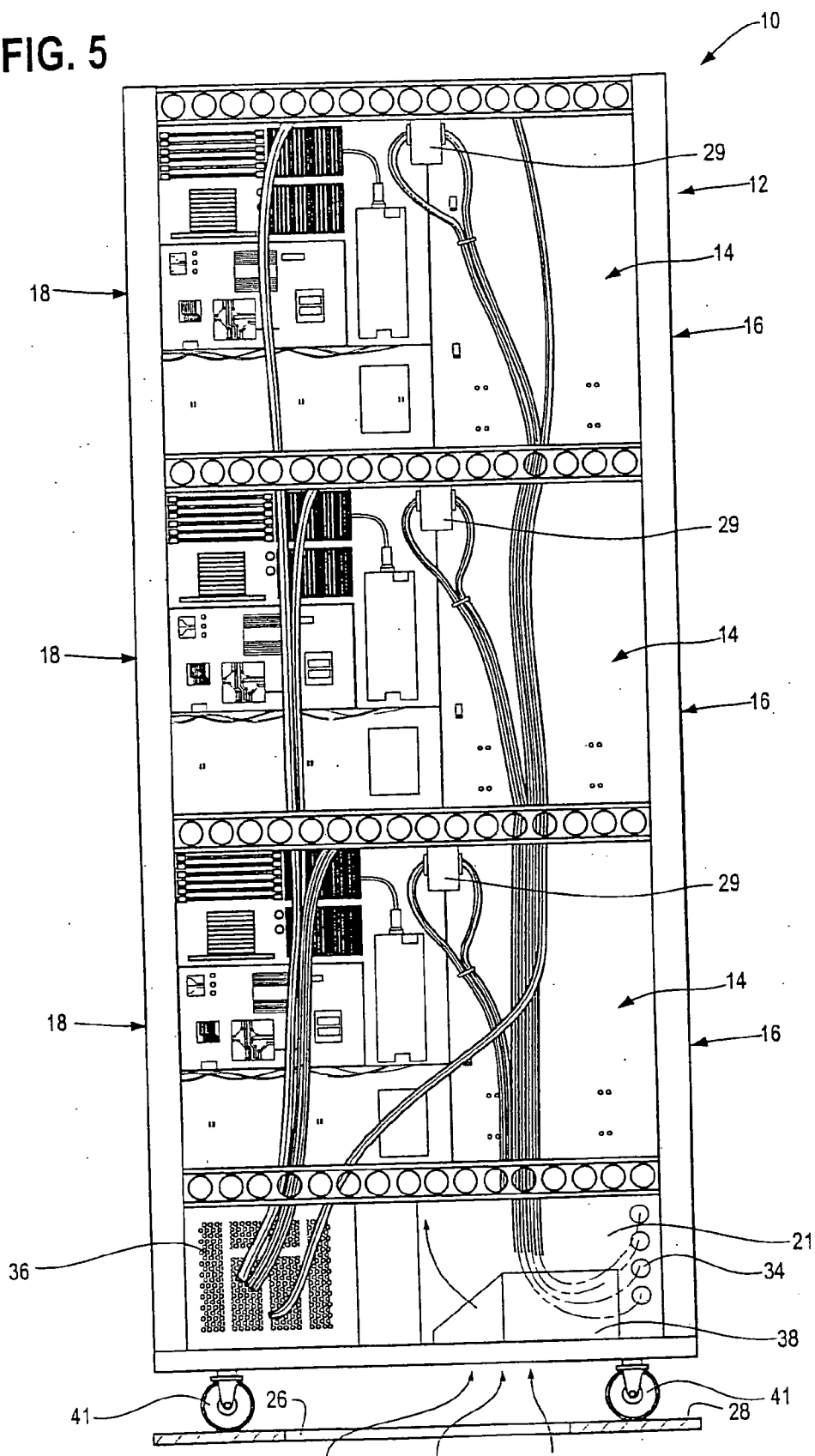

FIG. 6

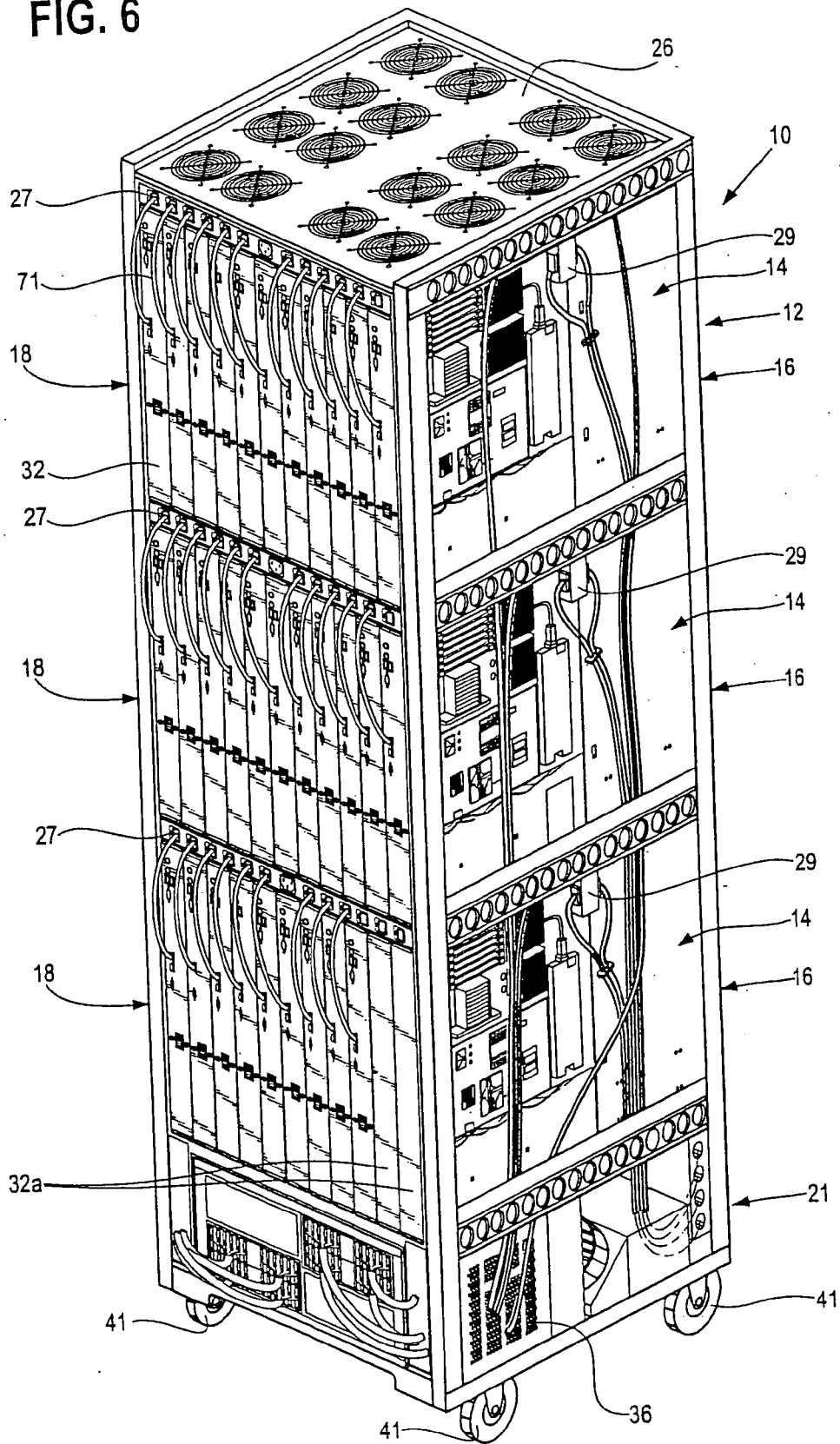

FIG. 7

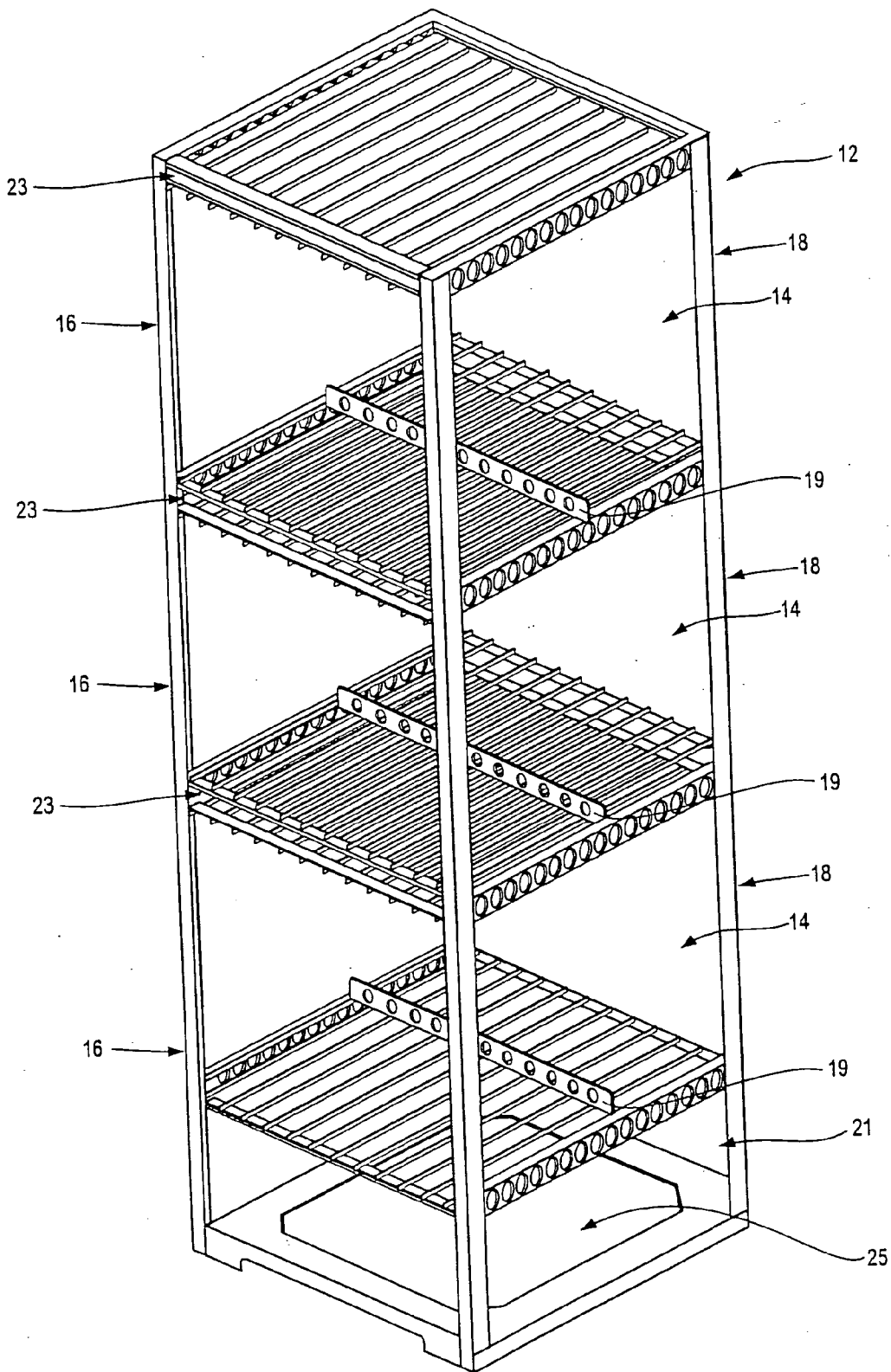

FIG. 8

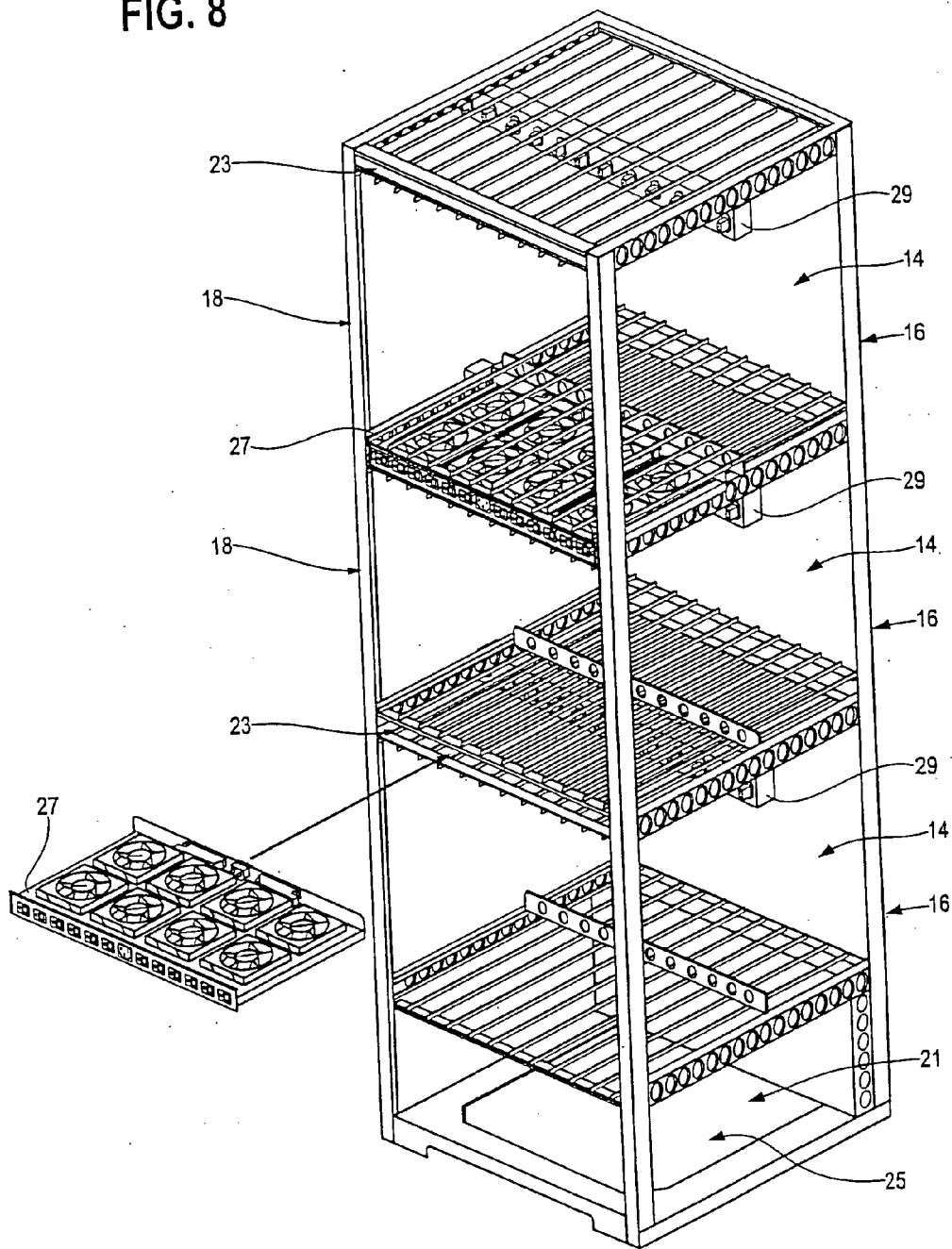

FIG. 9

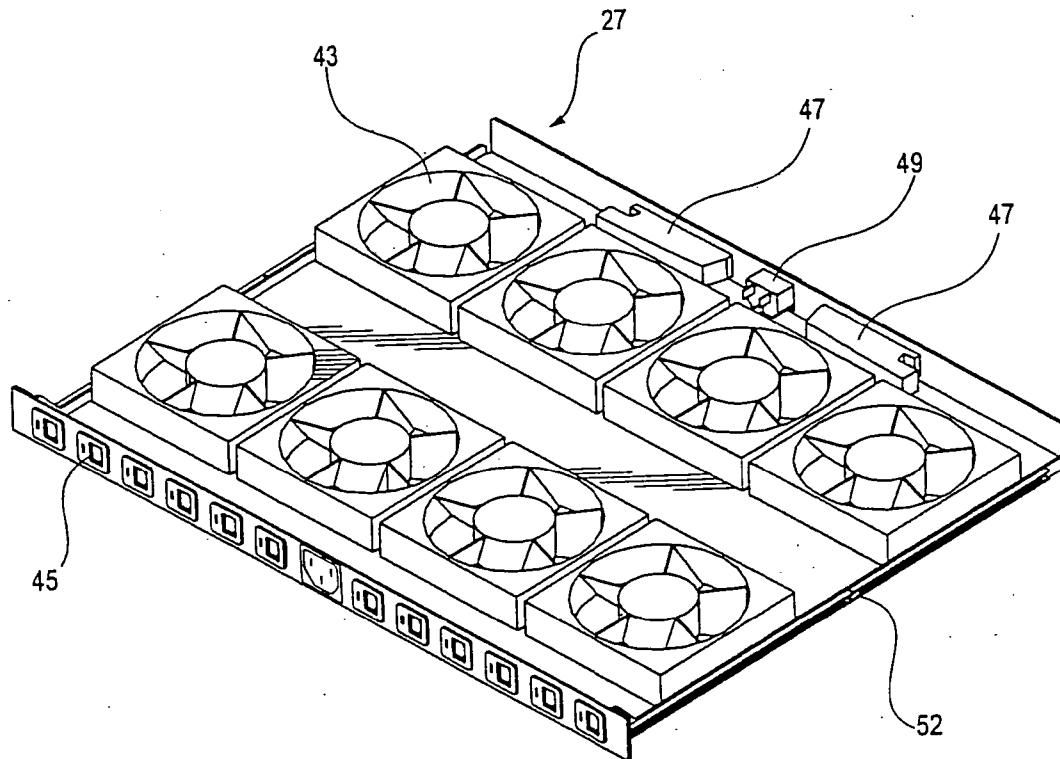

FIG. 10

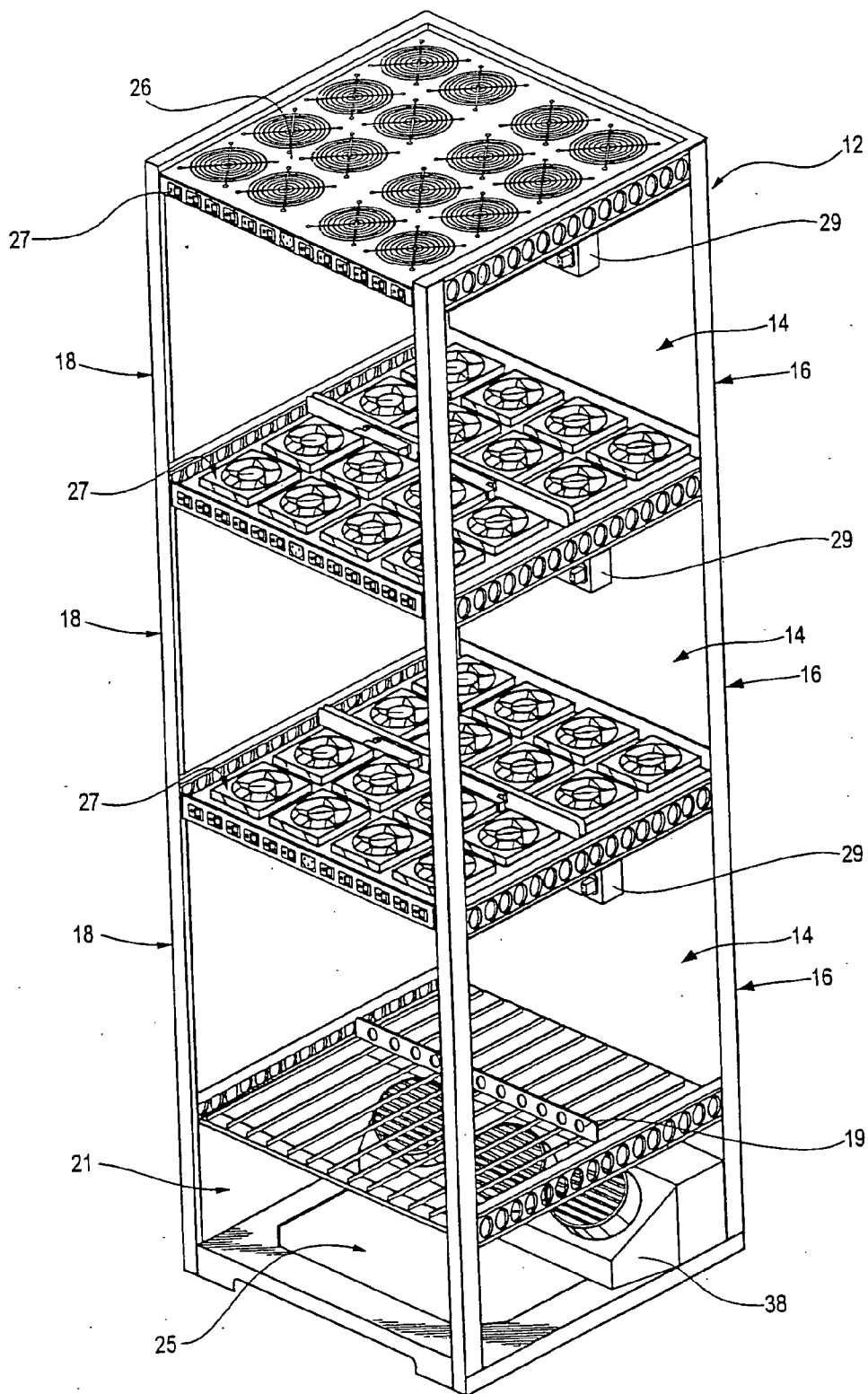

FIG. 11

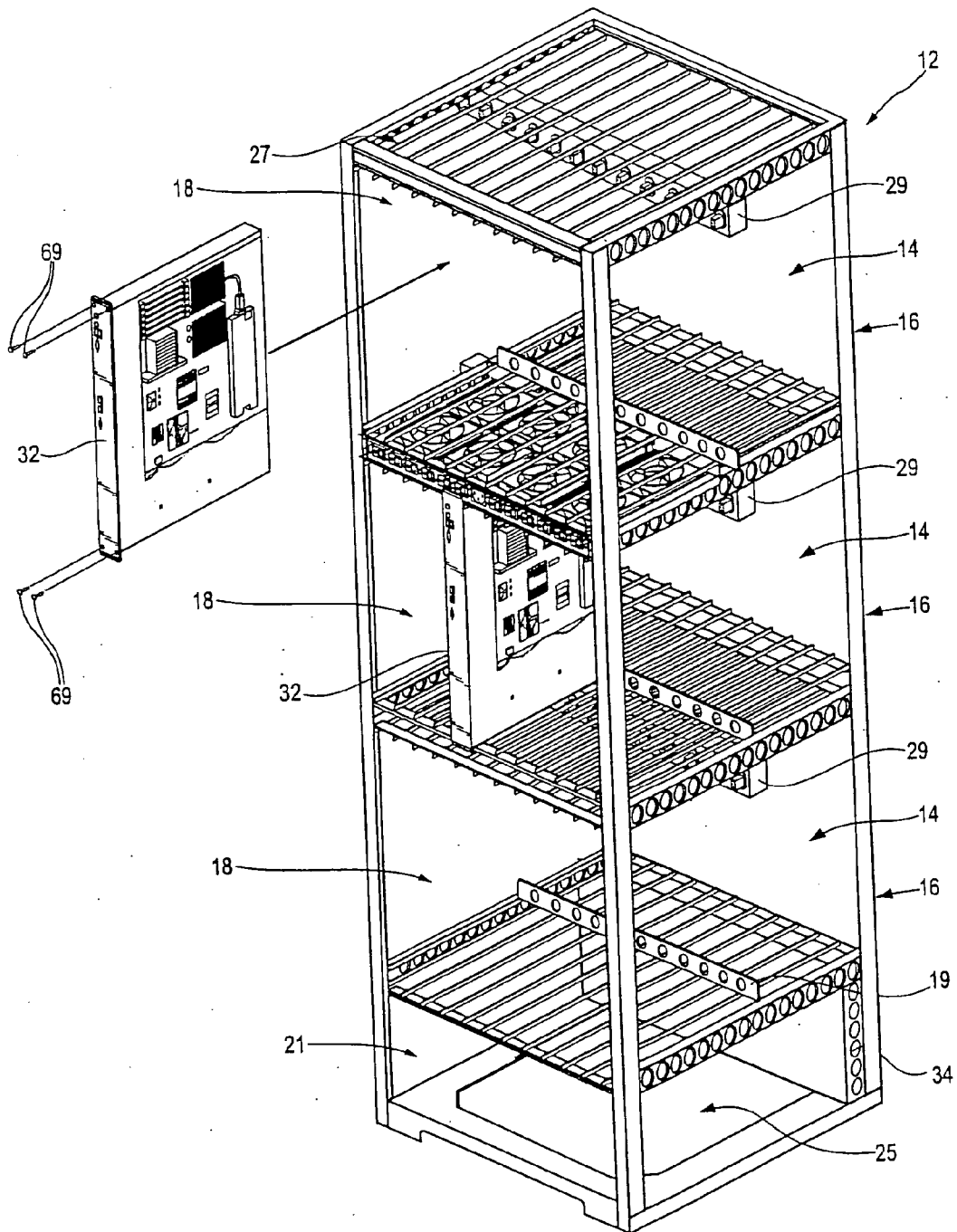

FIG. 12

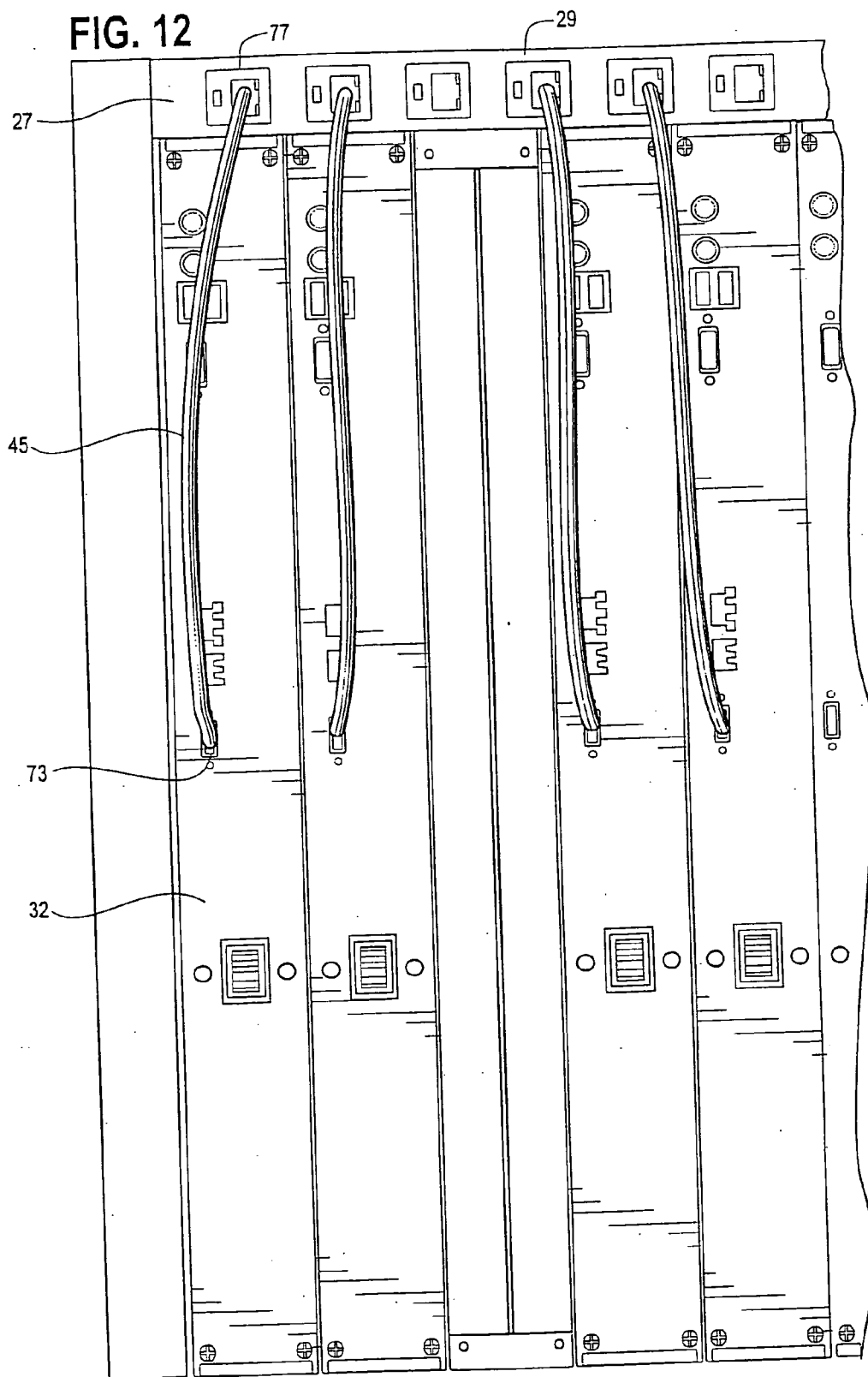

FIG. 13

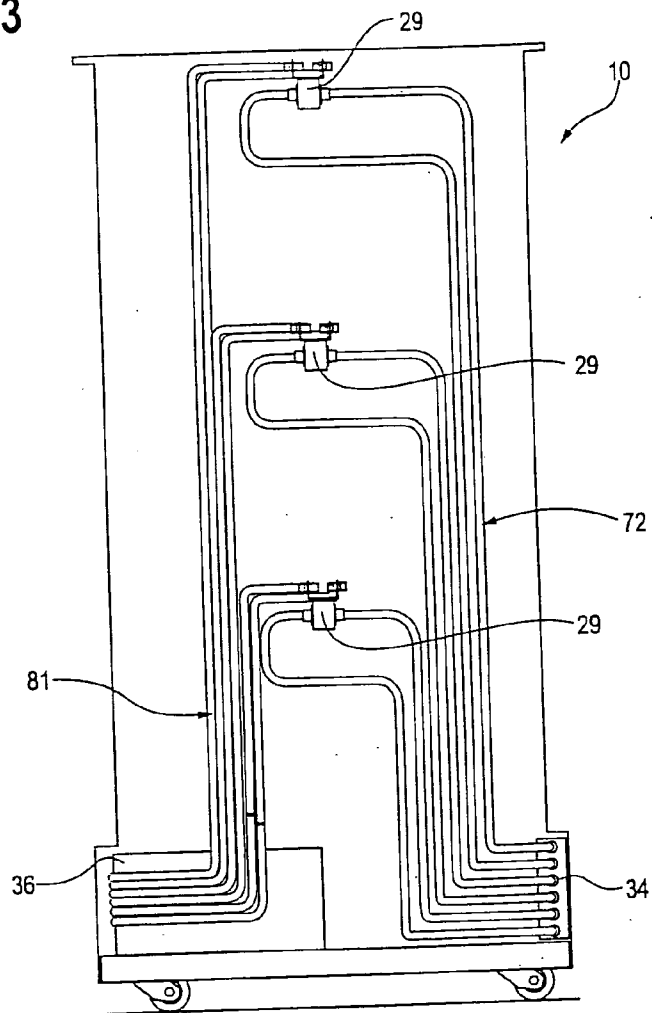

FIG. 14

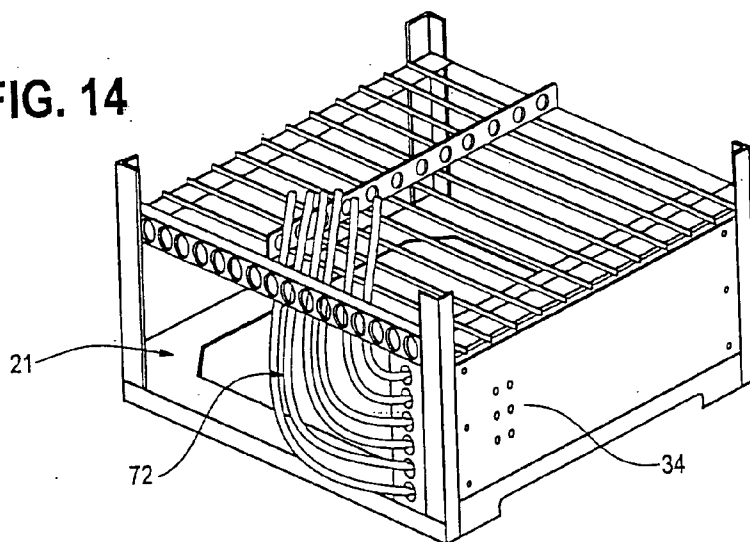

FIG. 15

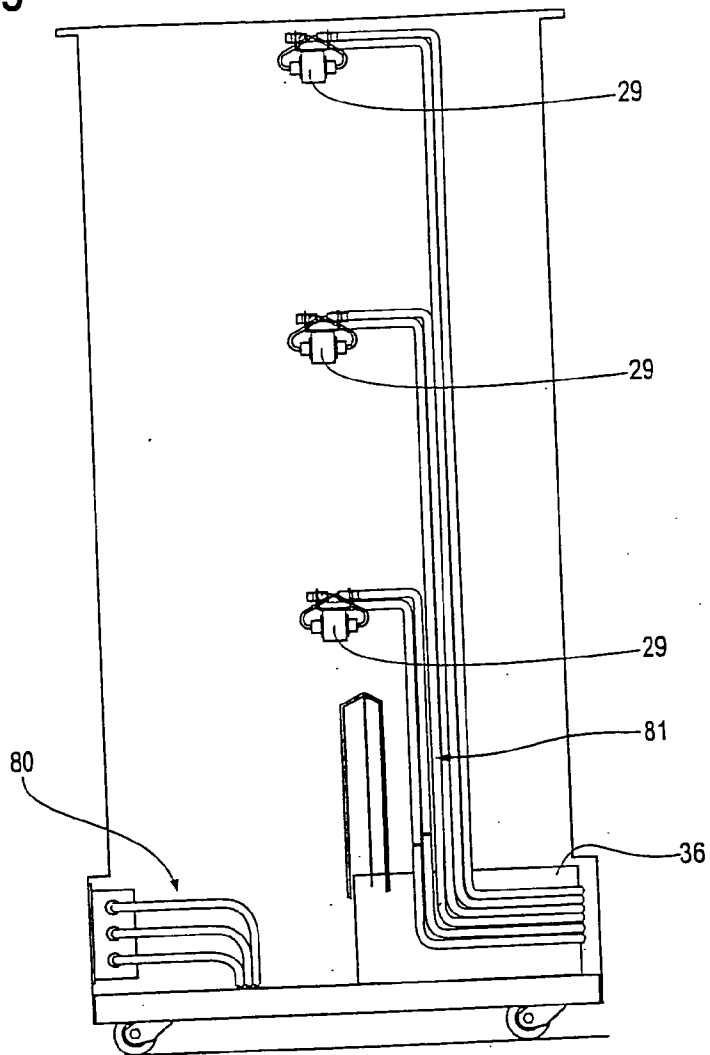
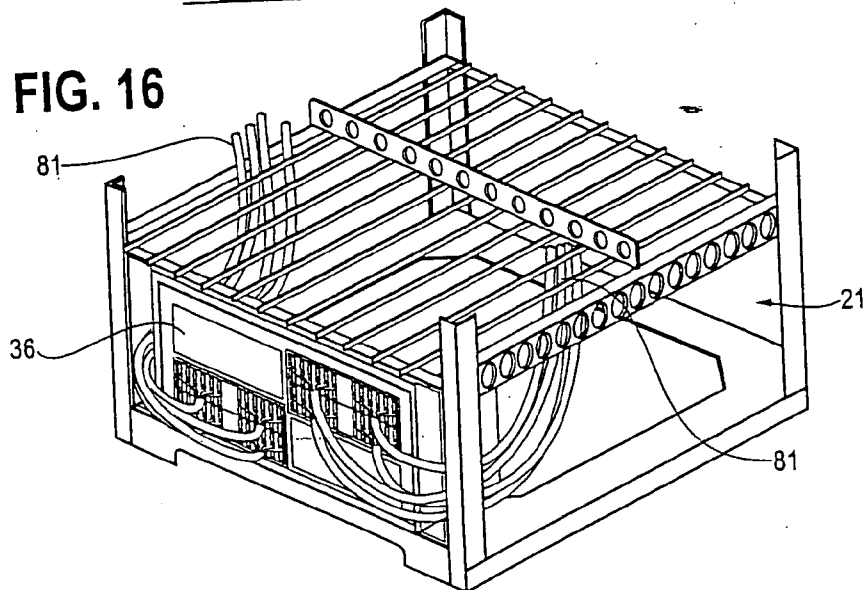

FIG. 16



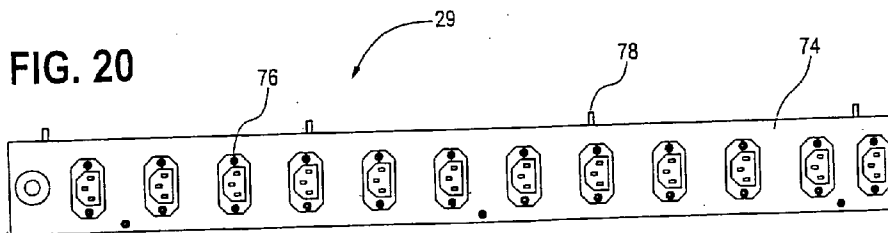
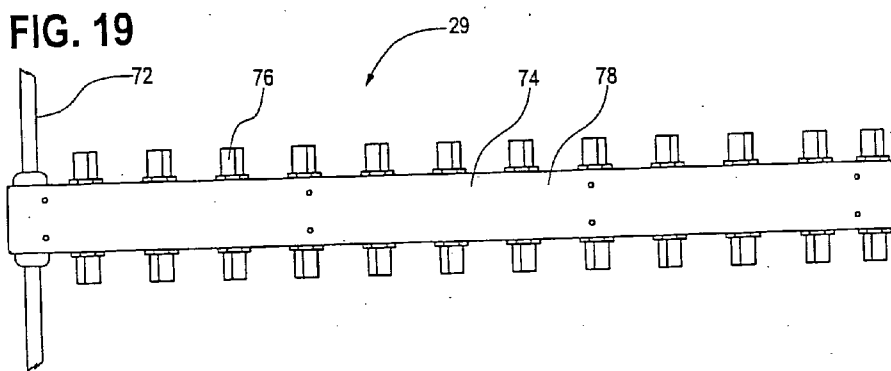
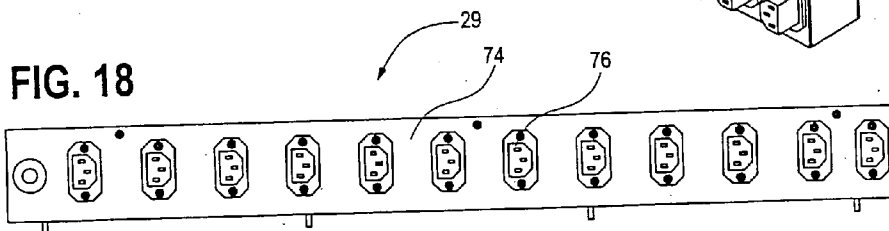
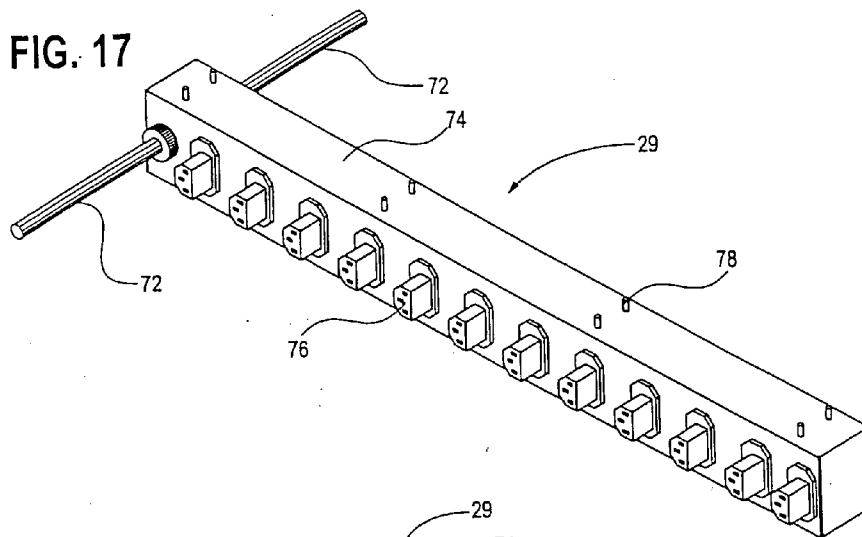

FIG. 21

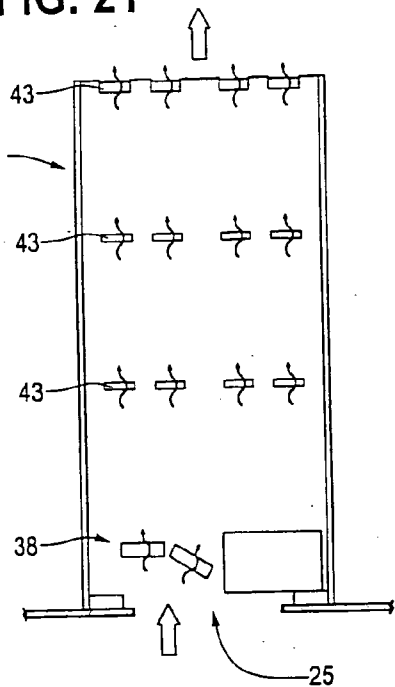

FIG. 22

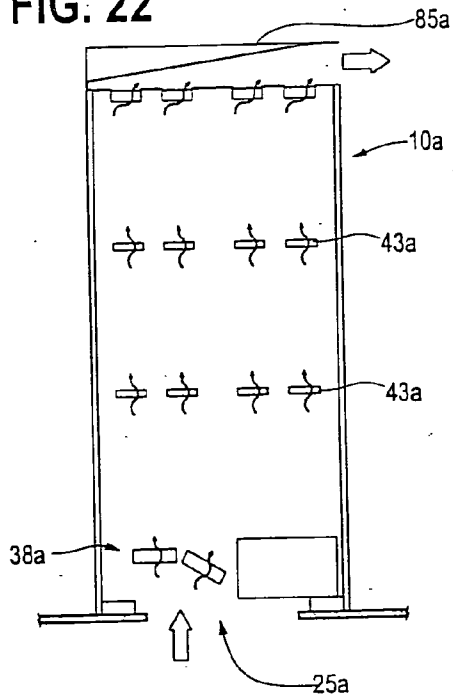

FIG. 23

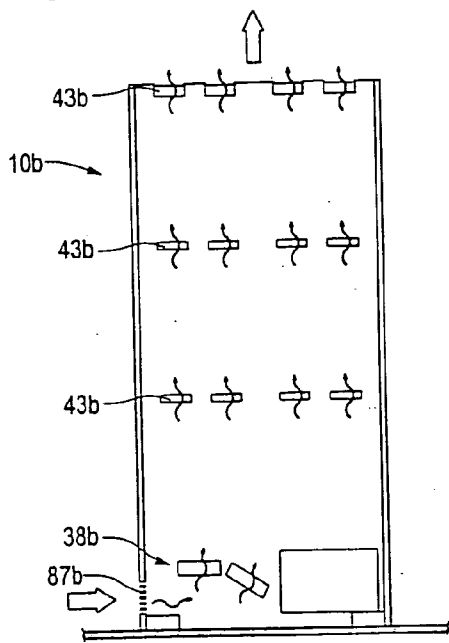

FIG. 24

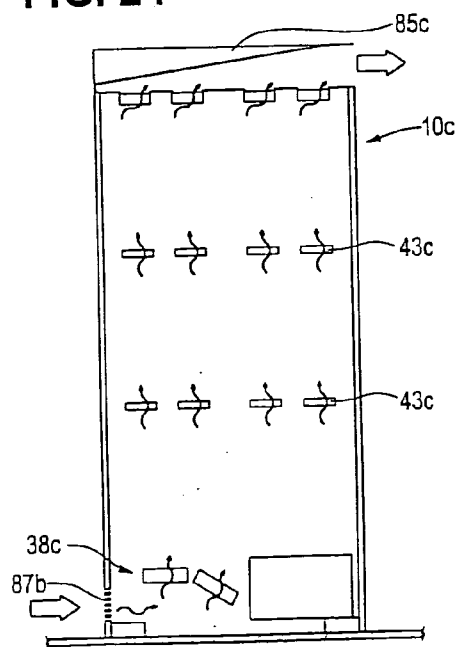

FIG. 25

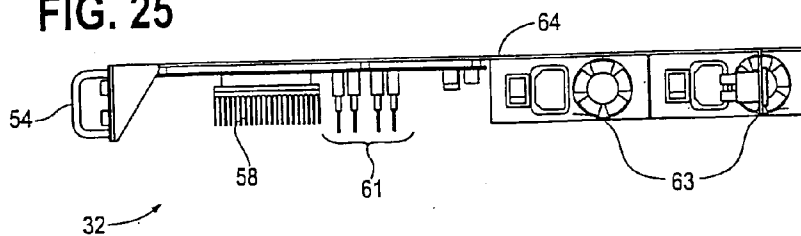

FIG. 26

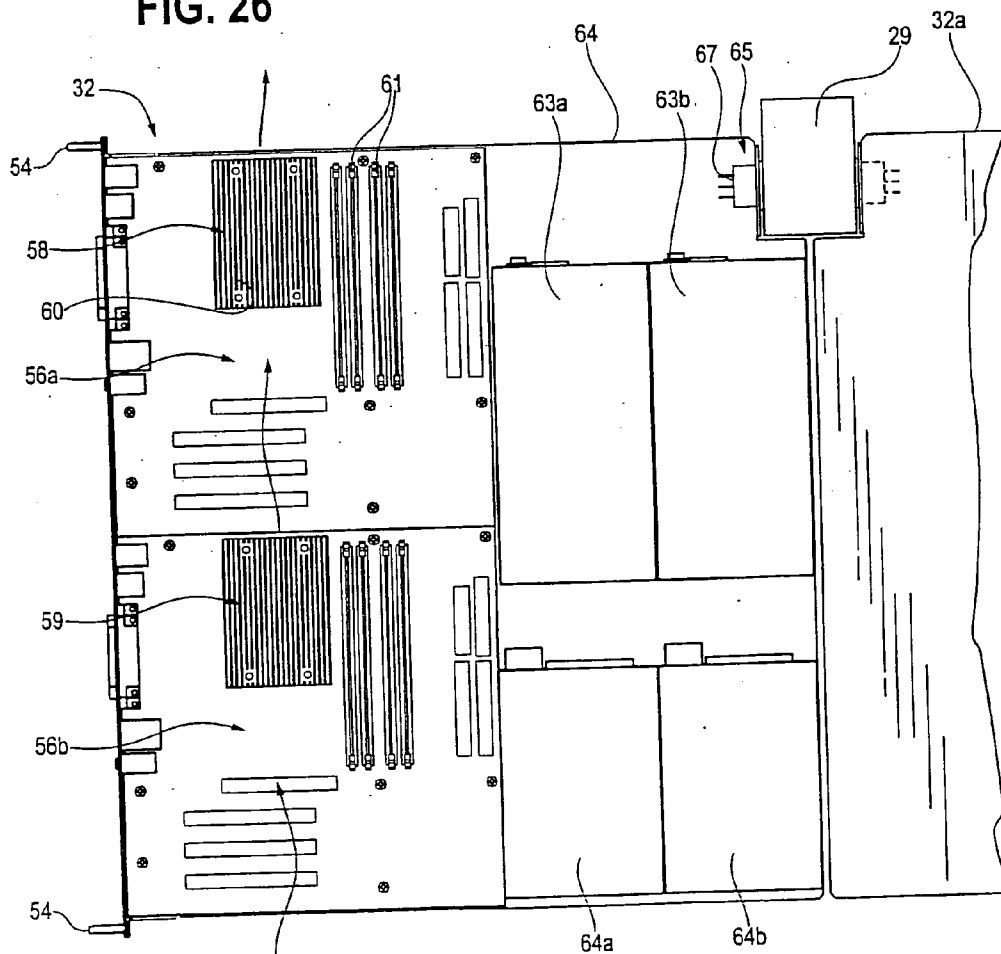

FIG. 27

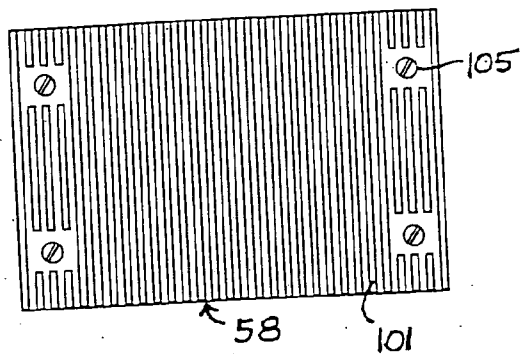

FIG. 30

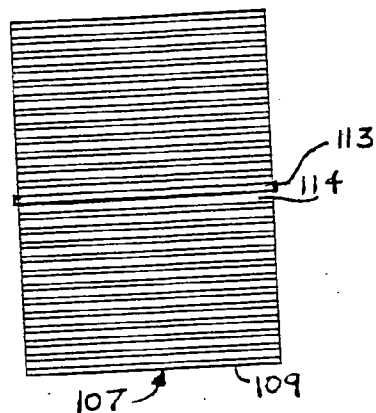

FIG. 28

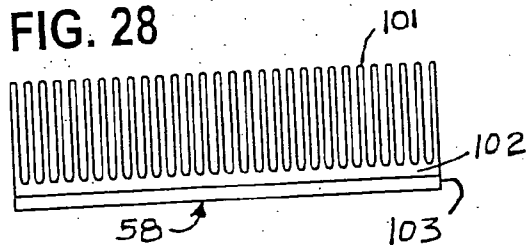

FIG. 31

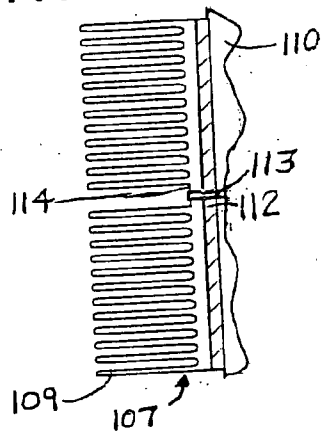

FIG. 29

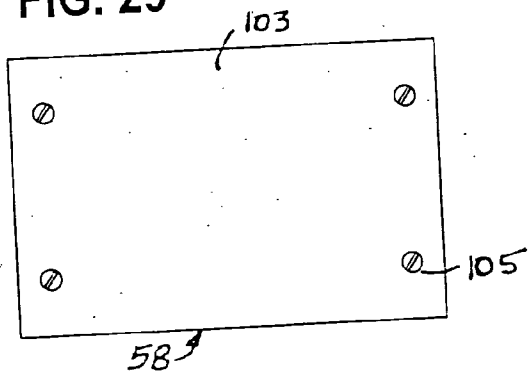
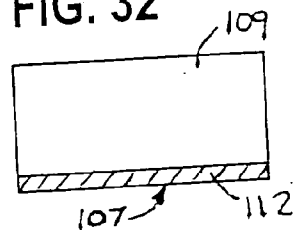

FIG. 32



RACK MOUNTABLE COMPUTER COMPONENT FAN COOLING ARRANGEMENT AND METHOD

CROSS REFERENCE TO RELATED APPLICATION

[0001] This application is a Divisional Patent Application under 37 C.F.R. § 1.53 (b) of U.S. patent application Ser. No. _____, Attorney Docket No. 7719-112, application Ser. No. 10/449,608, "Rack Mountable Computer Component Fan Cooling Arrangement And Method", filed on May 29, 2003, and is incorporated by reference.

RELATED APPLICATION

[0002] This application claims priority to the following U.S. provisional applications: Application No. 60/384,996, titled "Rack Mountable Computer Component and Method of Making Same", filed May 31, 2002; Application No. 60/384,987, titled "Rack Mountable Computer Component Cooling Method and Device", filed May 31, 2002; Application No. 60/384,986, titled "Rack Mountable Computer Component Fan Cooling Arrangement and Method", and Application No. 60/385,005, titled "Rack Mountable Computer Component Power Distribution Unit and Method", which are each hereby incorporated by reference in their entirety.

[0003] This application relates to the following U.S. non-provisional patent applications: application Ser. No. 10/449,799, titled "Rack Mountable Computer Component and Method of Making Same," filed May 28, 2003; application Ser. No. 10/448,691, titled "Rack Mountable Computer Component Cooling Method and Device," filed May 28, 2003; and application Ser. No. 10/448,508, titled "Rack Mountable Computer Power Distribution Unit and Method," which are each hereby incorporated by reference in their entirety.

BACKGROUND OF THE INVENTION

[0004] 1. Field of the Invention

[0005] The present invention relates in general to a new and improved method computer components adapted for rack mounting. It more particularly relates to such a method and apparatus for cooling computer components adapted to be mounted in a compact configuration.

[0006] 2. Related Art

[0007] There have been a variety of different types and kinds of methods and systems for mounting computer components. For example, reference may be made to the following United States patents:

U.S. Pat. No.	INVENTOR	ISSUE DATE
4,258,967	Boudreau	Mar. 31, 1081
4,879,634	Storrows et al.	Nov. 7, 1989
4,977,532	Borkowicz et al.	Dec. 11, 1990
5,010,444	Storrows et al.	Apr. 23, 1991
5,216,579	Basara et al.	Jun. 1, 1993
5,460,441	Hastings et al.	Oct. 24, 1995
5,571,256	Good et al.	Nov. 5, 1996
5,684,671	Hobbs et al.	Nov. 4, 1997
5,877,938	Hobbs et al.	Mar. 2, 1999
5,896,273	Varghese et al.	Apr. 30, 1999

-continued

U.S. Pat. No.	INVENTOR	ISSUE DATE
6,025,989	Ayd et al.	Feb. 15, 2000
6,058,025	Ecker et al.	May 2, 2000
6,075,698	Hogan et al.	Jun. 13, 2000
6,220,456 B1	Jensen et al.	Apr. 24, 2001
6,305,556 B1	Mayer	Oct. 23, 2001
6,315,249 B1	Jensen et al.	Nov. 13, 2001
6,325,636 B1	Hipp et al.	Dec. 4, 2001
Re. 35,915	Hastings et al.	Oct. 6, 1998
Des. 407,358	Belanger et al.	Mar. 30, 1999

[0008] As a result of having available a large number of different types and kinds of mounting techniques, a standard has been adopted for mounting computer components in racks according to a certain modular configuration: In this regard, computer components such as computer processor units, and the like, are mounted one above the other in a column in standard size rack configurations. The standard is referred to as the EIA-310-D Standard, as clarified by the Server Rack Specification (SSI).

[0009] The housing for each computer device must have a certain height dimensions according to the Standard. The height dimension must be a multiple of a standard unit "U". Thus, there can be computer components which are 1 "U" (standard unit) high or multiples thereof. Thus, there can also be standard rack mountable computer components which are 1 U, 2 U, 3 U, 4 U and so on.

[0010] Thus, according to the conventional currently-used standard, racks are provided for storage of computer components in tightly spaced, densely packed horizontal dispositions, and each computer component mounted in the rack is suitably dimensioned in multiples of standard unit U. The racks are movably mounted on casters or the like so that they can be readily positioned in, for example, a computer room having a tightly controlled air conditioning system to ensure proper cooling of the computer equipment.

[0011] It is highly desirable to configure the computer components in the rack in a compact and highly dense manner for some applications. Thus, it has been important for many applications to position in the computer room or other assigned space as many computer components as possible.

[0012] In order to compactly mount the computer components on the rack in a high density manner, they are closely positioned one above the other in a column. The data and power cables are positioned in a back plane area or space within the rack.

[0013] For cooling purposes, various techniques are employed. For example, individual fans have been mounted within the housing of each computer component. The interiors of the housing have been exhausted to a fan exhaust plenum chamber often times constructed within the rack at one side thereof.

[0014] Such conventional rack mounted systems have several drawbacks. The individual fans mounted in each component are expensive, and time-consuming to replace in case of malfunctions. Also, the back plane space and fan exhaust plenum chamber are wasted space in that they occupy spaces which could otherwise be filled with computer components.

[0015] Additionally, in order to assemble the rack mounted system for installation at the site, each component must be installed in place within the rack, and then the cabling for each unit is routed within the rack at its back plane space. Such an operation is time consuming, and therefore expensive since highly trained personnel are required to do such an installation. Furthermore, once installed, in order to replace a malfunctioning computer component, the entire system, or at least a substantial portion thereof, must be shut down so that the malfunctioning unit can be disassembled, and a replacement unit installed and reconnected electrically. This, too, is time consuming and expensive.

[0016] In order to help cool the electronic circuits within the computer component housing, intake and exhaust fans are employed. In this regard, typically there may be a plurality of intake fans located at the front of the component housing, and another set of fans for exhausting the air located typically at one side of the housing. Should one or more of the fans malfunction, the computer component must be taken out of service to either replace the entire computer component or replace the malfunctioning fan or fans. Such a delay in the functioning of the system is highly undesirable for many applications.

BRIEF DESCRIPTION OF THE DRAWINGS

[0017] The following is a brief description of the drawings:

[0018] FIG. 1 is a pictorial view of a rack-mounted system showing the front, left side and top thereof, which is constructed in accordance with an embodiment of the present invention;

[0019] FIG. 2 is a front elevational view of the rack-mounted system of FIG. 1;

[0020] FIG. 3 is a left side elevational view of the rack-mounted system of FIG. 1;

[0021] FIG. 4 is a rear elevational view of the rack-mounted system of FIG. 1;

[0022] FIG. 5 is a right side elevational view of the rack-mounted system of FIG. 1;

[0023] FIG. 6 is a pictorial view of the rack-mounted system of FIG. 1, showing the rear, right side and top thereof;

[0024] FIG. 7 is a pictorial view of the housing of the rack-mounted system of FIG. 1 without various components being mounted for illustration purposes;

[0025] FIG. 8 is a pictorial view of the housing of FIG. 7 illustrating the process of installation of fan/LAN trays;

[0026] FIG. 9 is an enlarged scale pictorial view of one embodiment of a fan/LAN tray for the rack-mounted system of FIG. 1;

[0027] FIG. 9A is an enlarged scale pictorial view of another embodiment of a fan/LAN tray for the rack-mounted system of FIG. 1;

[0028] FIG. 9B is an enlarged scale fragmentary pictorial view of the tray of FIG. 9A, illustrating some of the fans being removed;

[0029] FIG. 10 is a pictorial view of the housing of FIG. 7 with the fan/LAN trays installed;

[0030] FIG. 11 is a pictorial view of the housing of FIG. 7 illustrating the process of installation of blades;

[0031] FIG. 12 is a fragmentary, enlarged scale front elevational view of the rack-mounted system of FIG. 1 illustrating the relative positioning of the fan/LAN trays and the blades;

[0032] FIG. 13 is a diagrammatic, right-side elevational view of the rack-mounted system of FIG. 1 illustrating the configuration of the right-side cabling;

[0033] FIG. 14 is a bottom fragmentary pictorial view of the rack-mounted system of FIG. 1 illustrating the cabling in the front and right portion of the control bay;

[0034] FIG. 15 is a diagrammatic, left-side elevational view of the rack-mounted system of FIG. 1 illustrating the configuration of the left-side cabling;

[0035] FIG. 16 is a bottom fragmentary pictorial view of the rack-mounted system of FIG. 1 illustrating the cabling in the rear and left portion of the control bay;

[0036] FIG. 17 is an enlarged scale, fragmentary pictorial view of one embodiment of a power distribution unit (PDU) for the rack-mounted system of FIG. 1;

[0037] FIG. 18 is a front elevational view of the PDU shown in FIG. 17;

[0038] FIG. 19 is a fragmentary top view of the PDU shown in FIG. 17;

[0039] FIG. 20 is a rear elevational view of the PDU shown in FIG. 17;

[0040] FIG. 21 is a diagrammatic view of the rack-mounted system of FIG. 1 illustrating the flow of air therethrough;

[0041] FIG. 22 is a diagrammatic view of another embodiment of a rack-mounted system according to the present invention and illustrating the flow of air therethrough;

[0042] FIG. 23 is a diagrammatic view of yet another embodiment of a rack-mounted system according to the present invention and illustrating the flow of air therethrough;

[0043] FIG. 24 is a diagrammatic view of still another embodiment of a rack-mounted system according to the present invention and illustrating the flow of air therethrough;

[0044] FIG. 25 is an enlarged scale top view of one embodiment of a blade of the rack-mounted system of FIG. 1; and

[0045] FIG. 26 is a left side elevational view of the blade of FIG. 1;

DESCRIPTION OF CERTAIN EMBODIMENTS OF THE INVENTION

[0046] According to certain embodiments of the invention, there is provided an arrangement for cooling a series of closely spaced upright computer components mounted to a support, the arrangement including a tray having a plurality

of air moving devices such as fans. Members are used for helping mount removably the tray to the support in a generally horizontal disposition, and the air moving devices move air in a generally upright path of travel to help cool the upright computer components. The tray also has a series of connector ports for connecting electrically to outputs from individual ones of the computer components.

[0047] According to the other embodiments of the invention, the tray includes a front panel having the connector ports arranged in a row thereon. As disclosed herein, the front panel can be opened to permit access to the air moving devices or removing them for repair or replacement. The air moving devices can be removed from the support as a unit. Also, as disclosed herein, according to other embodiments of the invention, the air moving devices are arranged in separate sub groups and selected ones of the sub groups of air moving devices can be removed from the tray as a unit when the front panel is opened.

[0048] According to the disclosed embodiments of the invention, electrical cables connect the connector ports for conveying signals therefrom, and the cables have a sufficient slack portion to permit the front panel to be removed to an open position while maintaining the electrical connection to the connector ports. Thus, the air moving devices are "hot swappable" while the computer components remain in operation.

[0049] According to at least one of the disclosed embodiments of the present invention, there is provided a fan tray or unit which is adapted to be mounted horizontally within a rack to facilitate the movement of air vertically through computer components vertically mounted within the rack. In one example of the invention, a series of the fan trays are adapted to be disposed in a vertically-spaced apart manner within the rack. Each one is adapted to be removed and replaced, while permitting the computer components to continue to function normally.

[0050] General System Description

[0051] Referring now to the drawings, and more particularly to FIGS. 1 through 21 and 29 and 30, there is illustrated one embodiment of a rack mounted system 10 according to the present invention. The rack mounted system 10 includes a rack housing 12 configured generally as a rectangular box having a plurality of vertical bays 14. The embodiment illustrated in the drawings includes three vertically spaced-apart bays 14.

[0052] Each bay 14 is divided into a front bay portion 16 and a rear bay portion 18 by an intermediate transversely-extending horizontal divider 19. The intermediate divider 19 is most clearly illustrated in FIG. 7. The bays 14 are formed in the rack housing 12 in a vertical manner one above the other. In a bottom portion of the rack housing 12, a control bay 21 is provided to house various controlled components, as hereinafter described in greater detail.

[0053] The rack housing 12 further includes a fan/LAN tray slot 23 above each bay 14. Each fan/LAN tray slot is configured to accommodate a fan/LAN tray such as tray 27.

[0054] The embodiment illustrated in the drawings provides a control bay 21 (FIG. 7) having a bottom opening 25 (FIG. 7) for facilitating air flow to receive vertically moving air flow from a vent opening 26 in a floor 28 and vertically

through the system 10 as assisted by the fan/LAN trays. At the top of the rack housing 12, an apertured top panel 26 (FIG. 1) is provided to permit venting of the vertically moving air flow from the system 10.

[0055] At the top portion of each bay 14, in the intermediate region between the front bay portion 16 and the rear bay portion 18, as best seen in FIGS. 1, 5, 6 and 8, a power distribution unit (PDU) 29 is provided to supply electricity to various components mounted in the rack mounted system. Each bay is adapted to accommodate a plurality of computer components in the form of open structure computer components or blades, such as blade 32 (FIG. 1), in each of the front bay portions 16 and the rear bay portions 18. In the embodiment illustrated in the figures, eleven blades may be accommodated in each of the front bay and rear bay portions in a generally upright disposition. Thus, in the illustrated embodiment, the system 10 accommodates 66 computer components in a densely compact, closely spaced configuration.

[0056] The bottom control bay 21 is adapted to accommodate various control components. These control components may include a circuit breaker junction box 34, as most clearly illustrated in FIG. 6. The circuit breaker junction box 34 is electrically connected to each PDU. As shown in FIG. 4, a switch module 36 is also provided in the control bay 21. The switch module 36 is adapted to control communication between the various blades, such as blade 32, and a network, such as a local area network, wide area network, or a public network, such as the internet. Further, the control bay 21 accommodates an air intake fan module 38 (FIGS. 1 and 5) for facilitating intake of air through the bottom opening 25 and facilitating vertical air flow through the blades and the bays 14 and out the apertured top panel 26.

[0057] The embodiment of the rack system 10 illustrated in the figures includes four casters 41 for rollably supporting the system on the floor 26 (FIG. 5) for easy portability of the rack system 10. Other embodiments of the rack system according to the present invention may be floor mounted, thereby including legs or skids in place of the casters for direct mounting to the floor.

[0058] Fan/LAN Tray

[0059] Referring now to FIGS. 8 and 9, the fan/LAN tray 27 and its installation into the rack housing 12 will be described in further detail. FIG. 9 illustrates one embodiment of a fan/LAN tray 27 for mounting to a suitable support such as the rack system 10 illustrated in the drawings. The fan/LAN tray 27 includes eight suitable air moving devices such as fans for facilitating vertical air flow. Although the embodiment illustrated in the drawings includes eight fans such as fan 43 (FIG. 9) per tray, any suitable number of fans may be used.

[0060] In the front portion of the fan/LAN tray 27, a series of LAN connector ports 45 (FIGS. 1 and 9) is provided. In the embodiment illustrated in FIG. 9, each fan/LAN tray 27 includes 12 LAN connector ports 45, the end one of which may be used for test purposes. While 12 LAN connectors are shown in the disclosed embodiment, it should be understood that any number of such connectors may be employed for a given application. Internal wiring leads (not shown) from each LAN connector port 45 extend to one of two signal connectors 47 (FIG. 9) in the back portion of the fan/LAN

tray 27. In one embodiment, each signal connector 47 is a 50 pin signal connector, and is connected electrically to the switch module 36. Further, each fan/LAN tray includes an AC power inlet 49 in the back portion for providing power to the fans. When installed, power may be supplied to the fans such as fan 43 through the AC power inlet 49 from the PDU 29, as hereinafter described in greater detail.

[0061] For facilitating installation of the fan/LAN tray 27 into the fan/LAN tray slot 23 of the rack housing 12, as shown in FIG. 9, guides 52 may be provided on the sides of each fan/LAN tray 27. During the installation process, the guides, preferably nylon guides, may engage corresponding member on the sides of the fan/LAN tray slots 23 to help support the fan/LAN tray. Further, a locking mechanism may be provided in conjunction with the guides 52 for securing the fan/LAN tray 27 into the fan/LAN tray slot 23 to help support the fan/LAN tray. Once installed, each fan/LAN tray 27 occupies an area directly above either the front bay portion 16 or the rear bay portion 18. Accordingly, a fan/LAN tray in the front and a fan/LAN tray in the rear may completely cover each bay 14 level. Thus, as illustrated most clearly in FIG. 10, a total of 6 fan/LAN trays 27, in addition to the air intake fan module 38 may be provided in a three bay level rack mounted system 10 according to one embodiment of the present invention.

[0062] Referring now to FIGS. 9A and 9B, in accordance with another one of the disclosed embodiments of the present invention, a fan/LAN tray 42 which is similar to the fan/LAN tray 27, may be divided into a plurality of separate trays or tray portions such as a tray portion 44, each of which can be removed independently so that the remaining tray portion or portions can continue to function. In this regard, it is contemplated that the LAN connections are separate from the fan tray or tray portions so that the tray portions may be removed independently of the LAN component.

[0063] The fan tray 42 includes a generally rectangular flat hollow frame 46 having a series of guides such as guide 68 for helping to mount the fan tray 42 to a suitable support (not shown), which may be similar to the rack housing 12 of FIG. 1. The frame 46 includes a front opening 48 (FIG. 9B) for receiving the individual tray portions such as the tray portion 44. A removable front panel 51 fits over the opening 48 and is secured in place by any suitable technique such as by using fastening devices (not shown). A series of connector ports such as a connector port 53 are mounted on the front panel 51 and are electrically connected to signal connectors (not shown) which may be similar to the signal connectors 47 of FIG. 9. In this regard, cables such as a cable 55 are connected individually to the connector ports such as the connector port 53. In order to permit the removal of the front panel 51, the cables such as the cable 55 include cable slack portions such as a cable slack portion 57 to enable the front panel 51 to be removed from the frame 46, while permitting the electrical connections to the computer components to remain intact for normal operation of the system. In this regard, individual ones of the fan tray portions can be removed for repair or replacement, and the remaining fan tray portions can function independently to facilitate cooling, while the computer components remain in normal operation.

[0064] Considering now the tray portion 44 in greater detail, it should be understood that all of the tray portions

may be similar to one another. The tray portion 44 includes a front flange 59 to facilitate grasping by a user to pull it outwardly from the interior of the frame 46 as indicated in FIG. 9B. The fan tray portion includes a pair of air moving devices such as a fan 70, and a power inlet (not shown) similar to the power inlet 49 of FIG. 9 to engage a power outlet 60 on a power distribution unit 62 for energizing the fans. In this manner, the tray portion 44 can be pulled out of the frame 46 by merely disengaging it from the power outlet 60. Another like fan tray portion can then be inserted in its place and connected to the power outlet 60 and then the front panel 51 can then be replaced over the opening 48.

[0065] Thus, it will become apparent to those skilled in the art that the group of air moving devices can be arranged in subgroups of tray portions so that some but not all of the air moving devices can be removed without interfering with the operation of the remaining devices. It should be noted that the subgroups can be any number of one or more of the air moving devices. Also, it should be noted that the individual tray portions such as the tray portion 44 can be positioned behind the front panel 51, and a similar set of tray portions (not shown) can be installed to the rear portion of the frame 46 and interconnect with the power distribution unit 62. A rear panel (not shown) is removable and is similar to the front panel 51 and serves the same purpose as the front

[0066] Computer Component Construction

[0067] Referring now to FIGS. 11, 25 and 26, the computer components or blades 32 and their installation into the rack housing 12 will now be described in greater detail. Each blade is provided with a pair of handles 54 projecting from the front face of a front panel. The front panel extends transversely to a rigid upright support or plate and is connected to the front edge of the support in an L-shaped configuration. The handles allow a user to easily manipulate the blade 32 to be grasped by the user to slide the blade into or out of its bay. Each blade 32 may include one or more mother boards 56. In the embodiment illustrated in FIGS. 25 and 26, each blade 32 includes two mother boards 56a, 56b. Those skilled in the art will appreciate that the number of mother boards included in each blade 32 may be varied according to design. The mother board may include heat sinks such as heat sinks 58 and 59 for facilitating the cooling of the mother boards. Further, each mother board is provided with random access memory (RAM) 61. The amount of RAM 61 provided for each mother board may be varied as needed. A pair of power supply 63a, 63b may be provided on the blade 32 for supplying power to their corresponding mother boards 56a, 56b. Similarly, a pair of hard disks 64a, 64b may also be provided on the blade 32.

[0068] All of the components are mounted on one side of a rigid plate or support 64, which is adapted to be supported vertically within its bay. Each blade 32 includes a cut-out corner portion or section 65 in its upper back portion. The cut-out portion 65 is sized to receive and accommodate the PDU 29 there between such that two opposing blades 32 and 32a (as shown in FIG. 26) accommodate the PDU 29 almost completely. Thus, a substantially zero footprint is achieved for the PDU 29. Each blade 32 is provided with an AC power inlet such as an inlet 67 at or near the cut-out portion 65. Thus, when the blade 32 is installed into the rack housing 12, the AC power inlet 67 engages electrically a corresponding AC connector such as a connector 76 (FIG. 17) of the PDU 29.

[0069] As most clearly illustrated in FIG. 11, the installation of the blade 32 may be achieved in a fast and efficient manner. The blade 32 is simply slid into either the front bay portion 16 or the rear bay portion 18 of a bay 14 of the rack housing 12. Each blade 32 is slid back until its AC power inlet 67 engages a corresponding AC connector 76 on the PDU 29. The intermediate dividers 19 serve as a back stop for the blades 32. Each blade 32 is secured in its slot by four blade screws 69, which attach the blade 32 to the rack housing 12.

[0070] Once the blade 32 has been mounted onto the rack housing 12, a short blade/LAN connector cable such as a cable 45 (FIG. 12) or a cable 71 (FIG. 1) provides electrical networking connection between the blade 32 and a network such as a local area network, wide area network or a public network such as the internet. In this regard, the mother boards are each mounted at the front of each blade, and thus access thereto is readily available at front outlets such as at outlet 73 (FIG. 12). Thus, a data connection can be made from the outlet 73, through a short cable 45, an inlet 77 of a PDU 29, which is coupled to the switch module 36.

[0071] Referring now to FIGS. 17 through 20, the power distribution unit 29 will now be described in greater detail. The PDU 29 supplies power from an external power source, through the circuit breaker junction box 34, to the various blades 32 and the fan/LAN trays 27. Each PDU 29 includes an elongated PDU body 74, which preferably is formed of a two piece, 18 gauge steel chassis. Each of two sides of the PDU body 74 includes a series of female AC connectors 76. In the embodiment illustrated in FIGS. 17 through 20, each side is provided with 12 female AC connectors 76. The twelve connectors 76 correspond to eleven blades mounted in the front bay portion 16 and the rear bay portion 18 of each bay 14 and a fan/LAN tray 27. The twelfth connector is for an AC power outlet on the front of the fan tray.

[0072] Thus, 12 female AC connectors 76 are provided on each of a front side and a rear side of the PDU body 74. Each set of twelve female AC connectors 76 receives power through a pair of power cables 72. In one embodiment, the power cable 72 is a 15 amp power cable with strained relief near its junction with the PDU body 74. As described below, the power cables 72 are routed to the circuit breaker junction box 34 in the control bay 21. The PDU body 74 may also include a series of mounting studs 78 for installation of the PDU body 74 to the rack housing 12.

[0073] Referring now to FIGS. 13 through 16, the routing of the various power and LAN cables will now be described in detail. As illustrated most clearly in FIG. 13, the power cables 72 from the PDU's 29 at each bay level are directed along the right side of the rack housing 12 toward the front portion of the rack housing 12 and to the bottom, where they are connected electrically to the circuit breaker junction box 34. Thus, in the embodiment illustrated in the drawings, six power cables 72 are connected to the circuit breaker junction box 34, since there are two from each one of the three PDUs. A set of three cables generally indicated at 80 are each adapted to be coupled to a suitable source of AC power to supply power to the system 10.

[0074] As also illustrated in FIG. 13, a set of six LAN cables 81 from the fan/LAN trays and PDUs are routed along the rear right side of the rack housing 12 to the switch module 36. In the embodiment illustrated in the drawings,

two LAN cables 81 extend from each PDU which, in turn, are connected electrically to a pair of fifty pin signal connectors 47. Thus, six such cables 81 are directed along the right side of the rack housing 12. Similarly, as most clearly shown in FIG. 15, six LAN cables 81 extend from the fan/LAN trays 27 and PDUs along the left front side of the rack housing 12. These six cables 81 are also connected at their lower ends to the switch module 36.

[0075] Once the rack system 10 is fully assembled with all the fan/LAN trays 27, PDUs 29 and the blades 32 in place, a fully assembled and efficient rack mounted system is provided. In such a system, networking of the various components provided on the blades 32 is also performed efficiently. In the embodiment illustrated in the drawings, eleven blades are accommodated at each of the front bay portion 16 and the rear bay portion 18 at each bay 14. Thus, in the embodiment illustrated, 66 such blades 32 may be accommodated. However, some of the slots may be occupied by master computer components or blades such as the master blades indicated at 32a in FIGS. 4 and 6. In the illustrated embodiment, two master blades 32a are provided in the bottom of the three blade bays directly above the switch module 36. The master blades 32a are connected electrically directly to the switch module 36 via high speed connections (not shown) such as fiber optic connections. The master blades control the switch module 36 to switch communication between the various slave blades 32 and the master blades. Accordingly, 64 slave blades may be accommodated by the illustrated embodiment of the system. Each of the 64 slave blades may be hot swappable, for example, allowing replacement of the blades 32 without causing the shutting down of the system 10.

[0076] Each fan/LAN tray 27 is provided with twelve LAN connector ports such as the port 45 (FIG. 1). Eleven of the 12 LAN connector ports 45 are adapted to permit communication between the various slave blades 32 and the switch module 36. The twelfth LAN connector port 45 allows an external user to connect an external device such as a laptop computer to the network. Further, each fan/LAN tray 27 is provided with a centrally disposed AC power outlet for connecting such an external device.

[0077] According to the disclosed embodiments of the present invention, and as indicated diagrammatically in FIG. 21, the system 10 illustrated in the figures provides efficient air flow to maintain a cool operating temperature for the various components mounted on the blades 32. Air flow is directed from the bottom opening 25 by the air intake fan module 38 located in the control bay 21. The air intake fan module 38 directs the air flow vertically through the various open structure blades 32 at each bay level 14. The air flow is further facilitated by the fans 43 in each fan/LAN tray 27 to move the air in its upwardly directed path of travel. The air flow is directed out of the rack housing 12 through the apertured top panel 26.

[0078] FIGS. 21 through 24 illustrate further embodiments of the present invention. As illustrated in FIGS. 21 through 24, the intake and exhaust of the air flow may be varied to accommodate various configurations as to the availability of air supply in the immediate environment. For example, in FIG. 22, an air intake fan module 38a draws air from a bottom opening 25a, similar to that illustrated in the embodiment shown in FIGS. 1 through 21. Air flow is

directed vertically with the aid of fans 43a mounted on fan/LAN trays. However, unlike the previously described embodiment, in the embodiment illustrated in FIG. 22, the air flow is re-directed from a vertical path of travel at right angles to a horizontal path of travel out of the rack system 10a towards the rear of the rack housing. An air flow hood 85a facilitates the rearward re-direction of the air flow.

[0079] FIG. 23 illustrates yet another embodiment of the rack system according to the present invention. In this embodiment, an air intake fan module 38b draws air horizontally inwardly through an opening such as defined by a perforated plate 87b in the bottom front portion of the rack housing. The air flow is then re-directed upwardly with the aid of fans 43b mounted in fan/LAN trays. The air flow is directed vertically out of the top portion of rack system 10b.

[0080] In the embodiment illustrated in FIG. 24, an air intake fan module 38c draws air horizontally through an opening such as defined by a perforated plate 87c in the front bottom portion of the rack housing. The air flow is re-directed vertically through this system with the aid of fans 43c. The air flow is re-directed at right angles to a horizontal path of travel out of the rack housing rearwardly at the top of the rack housing. The rearward redirection of the air flow is facilitated by an airflow hood 85c. It will be appreciated by those skilled in the art that other variations on the intake and exhaust of the air flow are possible in accordance with other embodiments of the present invention.

[0081] While particular embodiments of the present invention have been disclosed, it is to be understood that various different modifications and combinations are possible and are contemplated within the true spirit and scope of the appended claims. There is no intention, therefore, of limitations to the exact abstract and disclosure herein presented.

What is claimed is:

1. A cooling arrangement for cooling a series of closely spaced upright computer components mounted to a support, comprising:

- a frame adapted to be mounted on the support;
- a tray having a plurality of air moving devices removably mounted within the frame;
- members for helping mount removably said tray within the frame in a generally horizontal disposition;
- said air moving devices for moving air in a generally upright path of travel to help cool the upright computer components; and
- an upstanding removable front panel on the frame for permitting the tray to be withdrawn from the frame when the front panel is removed therefrom.

2. A cooling arrangement according to claim 1, further including connector ports arranged in a row at the front panel.

3. A cooling arrangement according to claim 2, wherein said front panel can be opened to permit access to said air moving devices.

4. A cooling arrangement according to claim 1, wherein said tray is arranged in separately removable tray portions.

5. A method of cooling a series of closely spaced upright computer components mounted to a support, comprising:

- using a frame adapted to be mounted to the support;
- using a tray having a plurality of air moving devices and a series of connector ports for connecting electrically to outputs from individual ones of the computer components;
- mounting the frame to the support;
- mounting removably the tray within the frame behind a front panel in a generally horizontal disposition;
- utilizing the air moving devices to move air in a generally upright path of travel to help cool the upright computer components; and

removing the front panel from the frame for permitting the tray to be withdrawn from the frame.

6. A method according to claim 5, further including arranging the tray in a plurality of separately removable subtrays, and removing individual ones of the subtrays.

7. A method according to claim 6, further including providing connector ports arranged on the openable front panel, and further including opening the front panel and removing at least one of the subtrays from the frame while maintaining the electrical connection to the connector ports.

8. A cooling tray for cooling a series of closely spaced upright computer components mounted to a support, comprising:

- a frame adapted to be mounted on the support;
- a tray having a plurality of air moving devices for mounting within the frame;
- a removable upstanding front panel over an access opening in the frame;
- guide mounted on the frame for helping mount removably said tray to the frame in a generally horizontal disposition;
- said air moving devices for moving air in a generally upright path of travel to help cool the upright computer components; and
- at least one signal conductor mounted on the back portion of the frame and electrically connected to the air moving devices.

9. A cooling arrangement according to claim 8, further including connector ports arranged in a row at the front panel.

10. A cooling arrangement according to claim 9, wherein said front panel can be opened to permit access to said air moving devices.

11. A cooling arrangement according to claim 8, wherein said tray is arranged in separately removable tray portions.

* * * * *