

June 6, 1961

L. H. CHAPMAN

2,986,937

LINEAL YARDAGE METER ATTACHMENT FOR GOLF CLUBS

Filed May 14, 1956

2 Sheets-Sheet 1

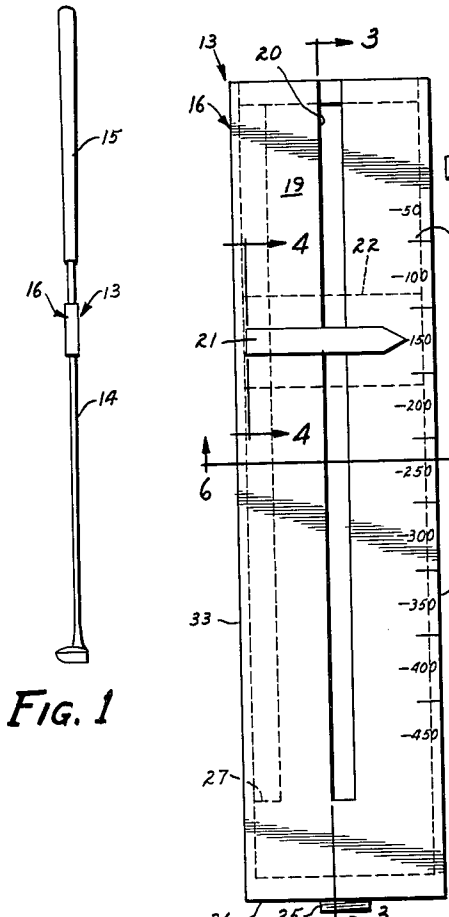

Fig. 1

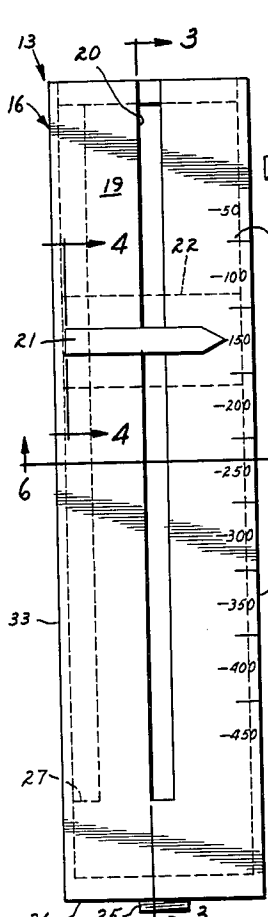

Fig. 2

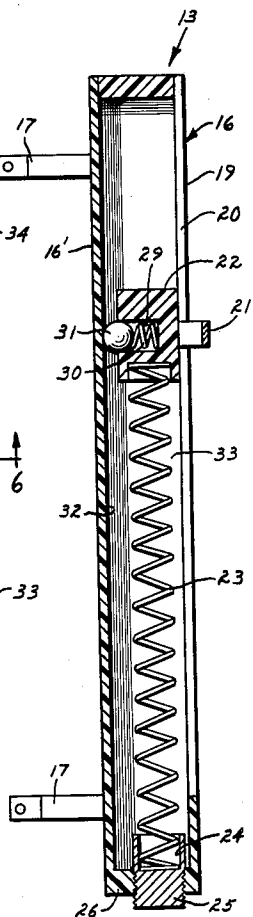

Fig. 3

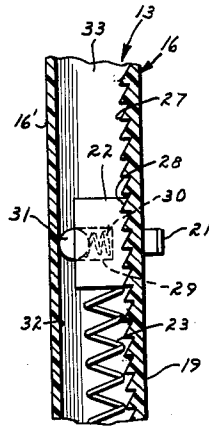

Fig. 4

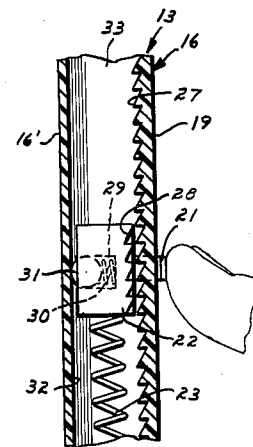

Fig. 5

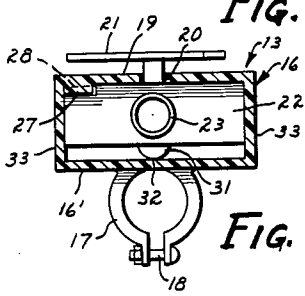

Fig. 6

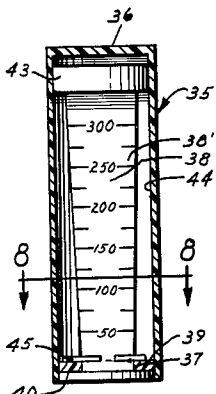

Fig. 7

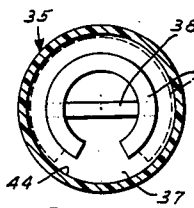

Fig. 8

INVENTOR.  
LOYAL H. CHAPMAN  
BY *David H. Kellogg*  
ATTORNEY

June 6, 1961

L. H. CHAPMAN

2,986,937

LINEAL YARDAGE METER ATTACHMENT FOR GOLF CLUBS

Filed May 14, 1956

2 Sheets-Sheet 2

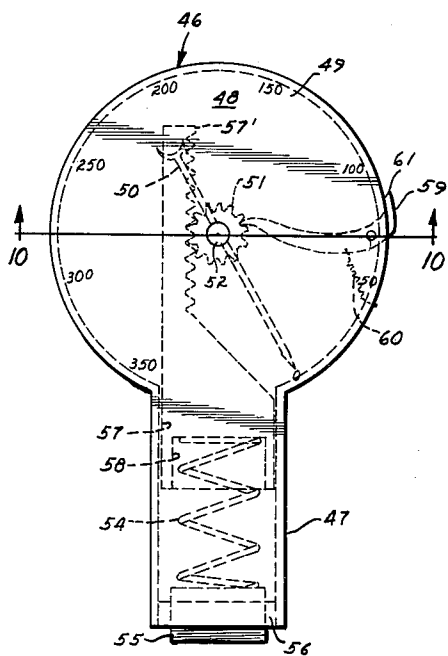

FIG. 9

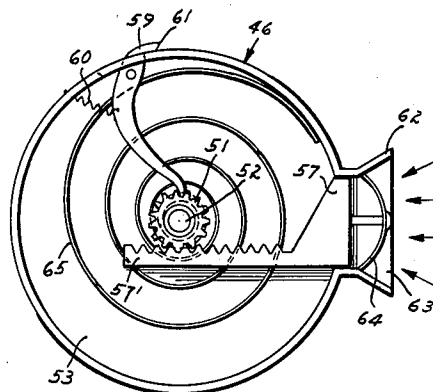

FIG. 11

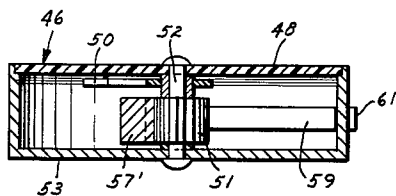

FIG. 10

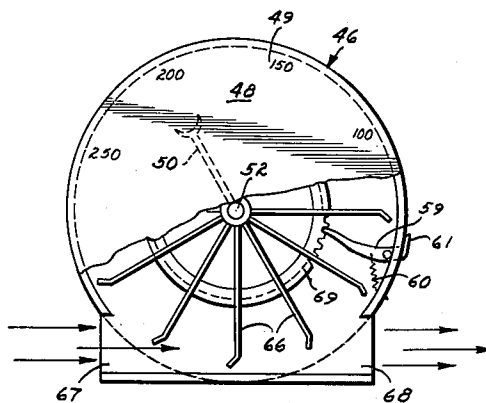

FIG. 12

INVENTOR.  
LOYAL H. CHAPMAN  
BY *David K. Kilgus*  
ATTORNEY

1

2,986,937  
**LINEAL YARDAGE METER ATTACHMENT FOR GOLF CLUBS**

Loyal H. Chapman, 813 National Bldg.,  
 Minneapolis, Minn.

Filed May 14, 1956, Ser. No. 584,836

1 Claim. (Cl. 73-379)

My present invention relates, broadly, to the field of devices for calculating and recording lineal measurements and, particularly, to a device applicable to a golf club whereby the force and speed of the swung golf club will transmit to an indicator on said club the approximate yardage a free golf ball would travel as the result of being struck by the head of the swung club.

It is well known and obvious that it is difficult for a player to practice the art of swinging a golf club properly by continually driving a ball that is either limited in its flight from the club head by restraining means anchoring the same to a given point, by the use of a simulated ball having practically no weight whatever, or by driving a regulation ball into a restraining net or enclosure to limit its free flight. Obviously, one of the foregoing means must be relied upon for practicing the proper swinging of the club when such activity is engaged in by a player indoors or within the confines of a private yard. Such conditions, even at their best, are relatively meaningless to the player because even though the impact of the club head on the practice ball may have the right feel and sound, the player is soon prone to abandon such practice because there is no indication whatever as to how true the flight of such a driven ball would be or how great a distance it would have covered, admittedly two of the most important factors in the game of golf.

The principal object of my present invention is to provide a device applicable to conventional, simulated or especially designed practice golf clubs whereby the force of the swing through atmosphere at an imaginary teed ball, or the impact of the head of a swung golf club upon a teed ball under restraint, will indicate on a recording scale or dial, the approximate distance in yards that a free ball would have travelled.

A still further object is to provide a device applicable to a golf club that will permit the use of a full swing without the use of a free ball and still indicate the approximate distance such a hit ball would have travelled.

These and other objects of my invention will be apparent from the following specification, claims and drawings which illustrate the invention and in which like characters indicate like parts throughout the several views.

Referring to the drawings:

FIG. 1 is a front elevational view of a golf club with one embodiment of the invention attached thereto;

FIG. 2 is an enlarged front elevational view of the invention detached from the golf club;

FIG. 3 is a side elevational view in section taken on the line 3-3 of FIG. 2;

FIG. 4 is an enlarged view partly in section taken on the line 4-4 of FIG. 2 showing one embodiment of the invention and the means for arresting return movement of the indicator after the same is activated by the swing of a golf club;

FIG. 5 is a view similar to FIG. 4 but showing the means for releasing the indicator permitting it to return to normal;

FIG. 6 is a sectional view of the invention taken on the line 6-6 of FIG. 2;

FIG. 7 is a sectional view of another form of the invention;

FIG. 8 is a sectional view of the modification shown in FIG. 7, taken on the line 8-8 of FIG. 7;

2

FIG. 9 is a top plan view of another form of the invention, some of the parts being sectioned;

FIG. 10 is a side elevation in section of the device shown in FIG. 9, taken on the line 10-10 of FIG. 9;

FIG. 11 is a top plan view of another form of the invention, its cover member being removed to show the working parts; and

FIG. 12 is a top plan view of still another modification with some parts broken away to show some of the working parts.

FIGURES 1 through 6 show one embodiment of the invention wherein FIG. 1 shows my novel yardage indicator 13 attached to the shaft 14 of a conventional golf club known as a "wood," near its grip portion 15. It must be understood at this point that while my indicator is shown attached near the upper end portion of the shaft 14, experimentation may prove that a lower location on said shaft is more desirable for the operation of the device and hence provision is made for slidable movement of the device on the shaft 15, as will be presently seen.

The version of the invention shown in FIGURES 1 through 6 is actuated by centrifugal force created by the powerful swing of the club as would generally be the case in actual play of a ball with this type of club and in practice, it is this type of club that is most often used to develop control of the powered swing. It will, however, be understood that the several components comprising the device are capable of adjustment, thus making the device practicable for application to the iron clubs as well as the woods of a conventional set of golf clubs.

The numeral 16 indicates a rectangular housing having rigidly attached to its back member 16' a pair of clamps 17 for adjustably securing the indicator 13 at a predetermined position on the shaft 14 by means of a nut-equipped bolt 18.

Longitudinally disposed in the cover or face plate member 19 of the indicator 13 is a long relatively narrow slot 20 which affords a passageway for longitudinal movement of an indicator pointer 21 attached to a weight member 22 slidably mounted for longitudinal movements within the housing 16 with a working fit.

A long coiled spring 23 is removably disposed in the housing 16, is rigidly attached at its upper end portion to the weight member 22 and its lower end portion loosely impinges a relatively shallow seat 24 formed in the inner end portion of an adjusting screw 25 having screw-threaded engagement with one of the end portions 26 of the housing 16. This adjusting screw 25 serves not only as means for confining the spring 23 in the spring housing 16 but acts as a base of resistance to place the said spring under tension or strain and to adjust said tension relative to the position of the indicator on the shaft 14.

Formed integral with the inner side of the face plate cover 19, or otherwise secured thereto is a row of teeth 27 in the form of a relatively long rack which teeth cooperate with a plurality of teeth 28 formed in the upper surface of the weight member 22. Formed in the bottom portion of the weight member 22 is a bore 29 which is provided to house a relatively weak coiled spring 30 which, in turn, engages a ball 31 of slightly less diameter than the bore 29. This ball, in turn, normally rides in a race 32 with just enough strain on the spring 30 to keep the cooperating teeth 27-28 in very light engagement.

It will be understood that the weight member 22 is designed and constructed to fit within the housing 16 with a working fit wherein the side members 33 of the said housing act as guides to limit edgewise movement of the weight member 22. The indicator pointer 21 being integral with the weight member 22 serves a dual purpose by also affording a finger piece for resetting the device to zero after each swing of the club to which the indicator 13 is attached.

When it is desired to reset the device to a zero reading, finger pressure is merely applied to the indicator pointer 21 to depress the same, as shown in FIG. 5, permit the tensioned spring 23 to disengage the teeth 27—28 and to return the combined weight and indicator units 21—22, respectively, to the zero setting. It is important to state at this time that cover or face plate 16 is provided with a suitable yardage scale 34 with which the indicator pointer 21 cooperates and for the purpose of the invention will be graduated in lineal yards. It will be noted from examination of FIGS. 4 and 5 that the thickness of the weight member 22 is slightly less than the depth of the teeth 27—28, thus when the indicator pointer 21 is depressed, the ball 31 is retracted into the bore 29 against the tension of the spring 30, permitting the disengagement of the teeth 27—28 and slidable movement of the combined indicator pointer 21 and the weight member 22 in the slot 20. Obviously, during such movement of these said members, the travel of the ball 31 in the race 32 will facilitate and aid in the guiding of these units 21—22.

The invention thus far described employs the element of centrifugal force to actuate its moving parts, as hereinafter described. The player, using a conventional golf club with the indicator 13, properly affixed thereto on the shaft 14, takes the usual stance as would be the case in regular play. Said stance may incorporate either a golf ball under restraint, a ball of such nature as to render it incapable of free flight, or an imaginary ball. At this point the indicator pointer 21 is set at zero on the scale 34. The powered swing of the club activates the weight member 22 by invoking the element of centrifugal force which forces the said weight member and indicator pointer downwardly in the housing 16. The saw teeth forming the rack 27 and the cooperating teeth 28 on the weight member 22 are obviously set in such a manner as to permit the relatively smooth and easy movement of the teeth 28 on the downwardly projected weight over the teeth 27 forming the rack member by virtue of the relative weakness of the spring 30 in the bore 29. By the same token, as downward movement of the weight member 22 is terminated at the end of the swing, the force of the lightly tensioned spring 30 acting on the ball 31 acting on the back member 16' of the housing 16 will project the teeth 27—28 into engagement, thus preventing the return of the indicator pointer 21 and the weight member 22 to normal zero setting by action of the compressed spring 23. By so arresting return movement of the indicator pointer 21, the player may, of course, take a reading from the graduated scale to determine the approximate distance a free ball so struck would have travelled. The use of this device on a golf club obviously provides an incentive to practice, by providing visual results of the swing. Thereafter, the indicator pointer will automatically return to the zero setting by merely manually depressing the member 21 and disengaging the teeth 27—28, thus rendering the device operable for the next practice swing.

Referring now to the modification of the invention shown in FIGS. 7—8, this form of the invention also employs the element of centrifugal force to actuate its calibrated indicator and is also applicable to the shaft 14 of a conventional golf club. The numeral 35 indicates a substantially cylindrical housing having a top closure member 36 and a bottom closure member 37. Mounted within the housing 35 is an indicator bar 38 having calibrations thereon indicating lineal yardage. This indicator bar 38 extends slightly outwardly of the lower cover member of the housing 37 through a relatively narrow slot 39 formed therein. A stop shoulder 40 is formed on the extreme lower end portion of the indicator bar 38 to limit its return movement into the housing 35. The indicator bar 38 is tapered as shown in FIG. 7 for purposes that will presently be described.

An annular ring 43 encircles and is rigidly attached to the upper end portion of the indicator bar 38 and has

a loose working fit with the inner side walls 44 of the housing 35. Expansibly fixed to the inner side of the lower cover member 37 is a split ring 45 that encircles the indicator bar 38 and under tension and is provided to halt the return movement of the indicator bar 38. It may be well to note here that in this version of the invention, the element of weight is incorporated into the indicator bar 38 itself. When the golf club is swung in a normal manner, the element of centrifugal force will act upon the adjusted indicator bar 38, thus forcing it downwardly and outwardly of the housing 35 until such time as the swing is terminated and the action of the split ring 45 on the downwardly and outwardly projected indicator 38 overcomes the element of centrifugal force. The reading of the yardage scale 34 is obviously taken at the point and extent to which the said indicator is extended through the lower cover member 37.

FIGS. 9 and 10 present another embodiment of the invention wherein the element of centrifugal force actuates a weighted member which, in turn, cooperates with an indicator or dial as in this version. As shown in FIG. 9, the numeral 46 indicates a substantially round and relatively thin indicator housing having an appendage in the form of a relatively thin rectangular spring and weight housing 47 extending outwardly and downwardly of the housing 46. A cover glass 48 overlies a recording dial 49 for lineal yardage mounted within the housing 46. An indicator needle 50 and a small pinion 51 are rigidly mounted on a vertically disposed shaft 52 journaled in the base 53 and the recording dial 49 for rotation about the axis of said shaft 52. A relatively light coiled spring 54 is enclosed in the housing 47 and has for its base of resistance on its outer end portion an adjusting screw 55 that has screw-threaded engagement with the end cap 56 of the housing 47. The housing 47 is in communication with the interior of the housing 46 and a weight member 57, the inner end of which is terminated in a rack 57' that cooperates with the pinion 51 mounted on the shaft 52, is slidably mounted with a working fit for vertical movement within said housings. The inner end portion of the spring 54 is rigidly attached to a seat 58 formed in the base of the weight member 57. The purpose of the spring 54 is to exert a retracting strain on the weight 57 and the rack 57' and thus normally position the indicator needle 50 at zero yardage.

A dog 59 is journaled in the side of the housing 46 the inner end portion of which is normally held in engagement with the pinion 51 by means of a light spring 60. This dog 59 is so arranged as to permit free movement of the pinion in a counter-clockwise direction, but acts as a stop to arrest the return movement of the needle and pinion assembly to zero after the device has been actuated by centrifugal force. The outer end portion of the dog 59, indicated by the numeral 61, extends outwardly of the housing 46 to afford a finger piece to disengage the dog from the pinion and thus permit the assembly to rotate clockwise and return the needle 50 to a zero setting. It will be understood that minor adjustment of the moving parts of this form of the invention can be made either by tension on the shaft 52 or by means of an opposing spring, not shown, to compensate and adjust the device depending upon its location on the shaft 14 and the weight of the club itself. These latter adjustments will, of course, only be required in addition to the action of the spring 54 under strain to oppose the element of force and compensate for correct readings.

As in the other version of this device wherein the element of centrifugal force is employed to activate the mechanism, the instrument is attached at a predetermined point on the shaft 14 of the golf club, with the dial 49 pointing to the club head. The player forcefully swings the club at a ball under restraint or at an imaginary ball, thus projecting the weight member 57 downwardly against the strain of the spring 54. The downwardly projected weight 57 moves the race, actuates the rack 57' which is

5

in engagement with the pinion 51, the rotation of which imparts movement to the indicator needle 50. At the termination of the swing, the strain of the spring 54 overcomes the element of centrifugal force and arrests further movement of the mechanism. The action of the dog 59 permits the reading of the indicator needle 50 on the dial 49 which denotes the approximate yardage travelled by a free ball struck in the process of the swing just described.

FIGURE 11 depicts a form of the invention which so far as most of its working parts, to wit: the recording dial and cooperating needle, pinion, shaft, main housing, rack and pinion, and dog mechanism are concerned, are a duplication of the structure defined and shown in FIG. 9.

This version, however, differs from FIG. 9 in that it is activated by air pressure created by the swing of the golf club.

The device is attached to the club shaft 14 as previously described and comprises a relatively wide funnel-like intake port 62 in the side of the main housing 46. Mounted substantially in the throat 63 of the intake port 62 is a diaphragm 64 which, in turn, is in engagement with the pinion 51 as the motivating means for the recording mechanism, as described. The unit is mounted on the club with the mouth of the funnel-like port facing the direction of the swinging club and the force of the atmosphere on the diaphragm 64 forces the same inwardly, thus activating the mechanism against the strain of a hair spring 65 coiled within the housing 46 attached at its inner end to the shaft 52 and at its outer end to the housing 46 as a means of resistance against the force of the air on the diaphragm 64.

FIGURE 12 employs the medium of air pressure and the same components as described in connection with FIGS. 9-11 except that a system of vanes 66 radiate from the central axis of the shaft 52 into the path of an air stream introduced into the housing 46 at 67 and expelled through an opposing port at 68. A toothed gear 69 is rigidly attached to the vane assembly and cooperates with the dog 59 to halt return of the indicator needle 50 to zero at the termination of the swing, thus permitting a reading of the yardage. As in the case of the invention described in FIG. 11, the hair spring 65 is coiled with-

6

in the housing 46 to oppose the element of force and return the indicator needle to normal zero setting.

Although this device measures yardage, it actually is capable of indicating centrifugal force, speed, wind and/or air pressure and calibrates the same into yardage, thus being capable of other uses than that described herein.

While there are herein disclosed but a limited number of embodiments of the structure, process and product of the invention herein presented, it is possible to produce still other embodiments without departing from the inventive concept herein disclosed, and it is desired, therefore, that only such limitations be imposed on the appended claim as are stated herein, or required by the prior art.

What I claim is:

A lineal yardage meter attachment for golf clubs comprising in combination, a tubular housing having a constant internal diameter, an aperture in the lower end portion of said housing and means for detachably securing said housing to the shaft of a golf club, a downwardly tapered indicating member slidably mounted in said housing for endwise movements therein, said indicating member having lineal yardage indicia thereon and frictional engagement with the interior surfaces of said housing, said indicating member being projected through the said aperture in the housing during the swinging movement of the golf club by virtue of the centrifugal force imposed on the said indicating member and whereby centrifugal force is transposed into readable lineal yardage.

#### References Cited in the file of this patent

##### UNITED STATES PATENTS

1,020,551	Harania	Mar. 19, 1912
1,039,491	Collins et al.	Sept. 24, 1912
1,388,275	Low	Aug. 23, 1921
1,471,794	Leven	Oct. 23, 1923
1,712,537	White	May 14, 1929
1,712,609	Gibson	May 14, 1929
2,543,722	Hetzel	Feb. 27, 1951
2,630,012	Walker	Mar. 3, 1953

##### FOREIGN PATENTS

179,079	Great Britain	May 4, 1922
---------	---------------	-------------