

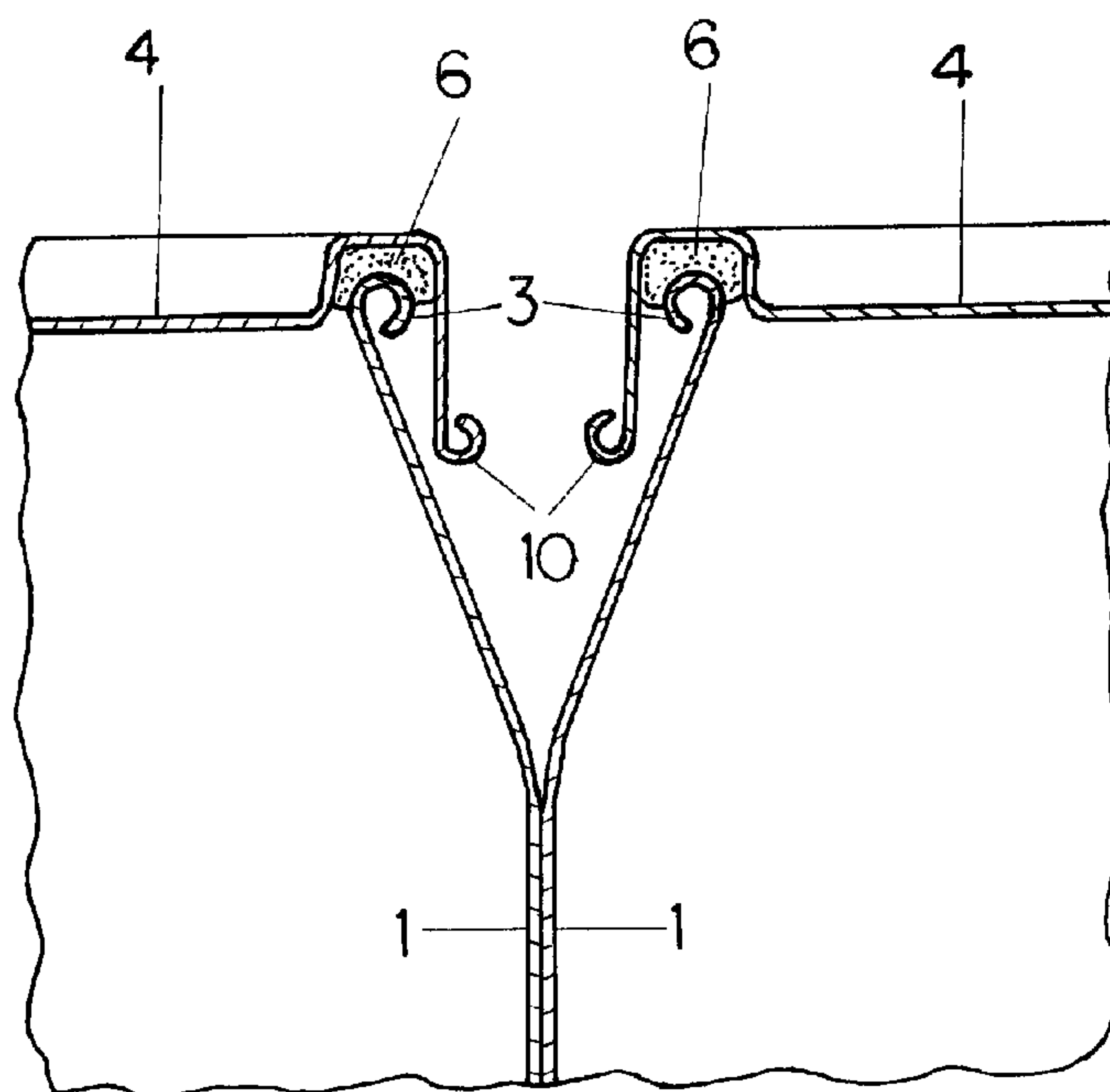

(22) Date de dépôt/Filing Date: 1997/01/03
 (41) Mise à la disp. pub./Open to Public Insp.: 1997/07/10
 (45) Date de délivrance/Issue Date: 2006/02/21
 (30) Priorité/Priority: 1996/01/10 (BR 9600045-7) BR

(51) Cl.Int./Int.Cl. *B65D 43/06* (2006.01)
 (72) Inventeur/Inventor:
 ROJEK, ARNALDO, BR
 (73) Propriétaire/Owner:
 METALGRAFICA ROJEK LTDA, BR
 (74) Agent: GOUDREAU GAGE DUBUC

(54) Titre : BOITES FERMEES SOUS VIDE AU MOYEN DE COUVERCLES METALLIQUES, NON CLOUES ET FACILES A OUVRIR, POUR EMBALLAGE DE PRODUITS ALIMENTAIRES
 (54) Title: VACUUM-CLOSURE CANS BY METALLIC, NON-NAILED, EASY-OPENING LIDS, FOR FOODSTUFF PACKING



(57) **Abrégé/Abstract:**

A can that is originally formed by an overall cylindrical body (1) with nailed bottom wall (2) and presenting on its superior part and close to the aperture a roundish fillet (3), outwardly turned, able to permit the application and closure of the can by means of a metallic, easy-opening lid, formed essentially by a circular panel (40), with short border or descendent skirt (5), provided by a narrow peripheral fillet (10), such a lid presenting a sealing gasket (6) on its internal surface and presenting, in the middle of its panel, a circular basin-shaped depression (7), with a central hollow (8) closed by a resinous, thermoplastic, detachable seal (9), yielding a new disposition in the superior part of the body of the can, by which the referred border or skirt (5) of the lid and its respective peripheral fillet (10) are presented reentrant and secluded in relation to the side wall of the cylindrical body (11) of the can, in a way that eliminates any possibility of leaning or friction and the consequent mounting or overlapping of the peripheral fillets (10), whenever cans are grouped or placed side by side, which otherwise may result in an accidental releasing of the lids.

ABSTRACT

A can that is originally formed by an overall cylindrical body (1) with nailed bottom wall (2) and presenting on its superior part and close to the aperture a roundish fillet (3), outwardly turned, able to permit the application and closure of the can by means of a metallic, easy-opening lid, formed essentially by a circular panel (4), with short border or descendent skirt (5), provided by a narrow peripheral fillet (10), such a lid presenting a sealing gasket (6) on its internal surface and presenting, in the middle of its panel, a circular basin-shaped depression (7), with a central hollow (8) closed by a resinous, thermoplastic, detachable seal (9), yielding a new disposition in the superior part of the body of the can, by which the referred border or skirt (5) of the lid and its respective peripheral fillet (10) are presented reentrant and secluded in relation to the side wall of the cylindrical body (11) of the can, in a way that eliminates any possibility of leaning or friction and the consequent mounting or overlapping of the peripheral fillets (10), whenever cans are grouped or placed side by side, which otherwise may result in an accidental releasing of the lids.

**VACUUM-CLOSURE CANS BY METALLIC, NON-NAILED,
EASY-OPENING LIDS, FOR FOODSTUFF PACKING**

Description of the invention

The present invention patent relates to some improvements introduced in vacuum-closure cans by non-nailed, easy-opening, metallic lids, for foodstuff packing.

The can for which the present improvements were realized is the object of Brazilian patent BR N° 9203029 of July 25, 1995 of the same inventor, which, in its original and well-known form, comprises essentially a cylindrical body with bottom wall normally fixed by nailing, comprising on its superior part and close to the top, a roundish fillet outwardly turned that allows the can to be closed by means of a non-nailed, easy-opening metallic lid. The referred lid is the object of Brazilian patent N° 9103906-0, of February 01, 1994 of the same inventor and such a lid essentially comprises a circular panel, presenting descendent edges or casings, provided with a narrow peripheral fillet; such a lid being provided with blocking gaskets and, on the panel thereof, with a circular depression with a central hollow, which is sealed by means of a resinous detachable seal.

It is important to notice that the realization of the present invention could not be feasible without the previous concretization of an easy-opening lid which has been successfully adopted in the closure of glass-made cups and pots. This allowed, by means of an innovative device introduced in such a can, this kind of lid to be used with the same practical advantages in tinned food closure.

Both the easy-opening lid and can realizations mentioned above required great efforts and investments in research and experiment, including the creation of special equipment and new technologies, in order to allow the execution of this package on high-production scales.

This kind of easy-opening can came to advantageously modify the traditional systems of metallic foodstuff packing closure, and distinguishes from

others basically by not comprising any mechanical device for lid fastening, excluding any other means for closure, as long as the lid is kept closed only by atmospheric pressure. It performs, therefore, a physical closure by elevating the vacuum formed in the interior of the package.

These vacuum-closure cans by non-nailed, easy-opening, metallic lids, have been advantageously distinguished from the conventional cans by their practical and utilitarian aspect, in the interest not only of manufacturers of foodstuff packing but also of consumers; thanks to the safety and simplicity that they offer against accidents - once the can is opened, it does not require any auxiliary device or effort, as long as the lid is released with the aid of a simple extraction of the label which is lifted with the edge of the nail and subsequently removed by the user's fingers.

Some inconveniences regarding closure were shown, during experiment, not only on the industrial operation line but also during storage, delivery and general manipulation. This is due to the fact that the closing process is delicate and is obtained only by vacuum action and through the application of vapour spargers; such a tinned product being, at this time, at a temperature higher than 194°F.

As long as the canned product temperature is very high, the vapour-sparger closing machine naturally forms a very low vacuum in the interior of the can, thus resulting, at this moment, in very low safety for the closure.

It must be considered that such cans, while submitted to the industrial process, undergo the following steps: filling, vacuum-closing, sterilizing and cooling. From one step to other, the cans are transported in rows and at high velocities in order to be automatically inserted into corresponding machines, and being then submitted to collisions and constrictions. During this critical process, the peripheral fillets placed on the outwardly projecting salient lids, lift up one over another, promoting accidental openings of the lids, as a result of the closure fragility due to the low vacuum. As a matter of fact, many losses in the

production occur, which makes it impossible for the sealing machine to provide a higher vacuum while the product in the cans is at temperatures higher than 194°F.

Such conditions cannot be modified during the closing process of the easy-opening cans mentioned above as long as the vapour sparge as well as the canned products are above 194°F. This requires the cans to be instantaneously closed to keep the vapour sparge in the free space that is formed above the product in order to condense and, thus, form the initial vacuum.

Therefore, as can be observed, these resulting high temperatures cannot be modified because a high vacuum (which is responsible for the safety of the closure) is needed.

Another problem found out during trials for this kind of package that will be, in the same way, solved through the present improvements, consists in the fact that, whenever the closed cans - provided with high vacuum and ready for transport and storage - are closely arranged and placed on the pasteboard boxes, they keep their peripheral fillets (placed on the lids) intimately supported and submitted to lifting among themselves. The action of the weight of the piles of boxes causes pressure of one fillet against the other and vibration during transport causing accidental opening of the cans, and thus, total loss of product.

In order to solve these inconveniences, and allow this kind of easy-opening to be perfectly safe against accidental opening, during the production process as well as during transport, storage or general manipulation, the present improvements were thought of by which - thanks to an innovative disposition introduced - it is possible to keep the peripheral fillets placed on the lids sufficiently separated or displaced in a reentrant manner in relation to the cylindrical body whenever the cans are closed and packed together. This allows the cans to be friction free and eliminates both undesirable mounting and superposition of these fillets.

The present invention not only focuses on a simple modification in the shape and dimensions of the can but also provides a new disposition, able to control the displacement of the peripheral fillet, as long as it is changed from an inappropriate and harmful position to another one that protects it from any damage, and eliminates the inconveniences aforementioned, as will be widely demonstrated on this descriptive report.

It must also be observed that such a modification, which comprises the object of the present improvements, does not interfere with any other constructive conception already known in metallic cans manufacturing as long as this closing system comprises, in its original shape, a creation of the same inventor and no similar inventions can be found all over the world. In such a closing system, only physical means are used since mechanical devices - such as clamps, nails or screw threads - are completely useless to secure the lid while in its closing position upon the aperture of the can.

The improvements introduced into vacuum-closure cans by non-nailed, easy-opening, metallic lids for foodstuff packing are represented by the following drawings:

Fig. 1 is a side view of the can, showing its improvements, such a can being closed by its respective lid;

Fig. 2 is a top view of the can and its respective lid;

Fig. 3 is a side view of two improved cans, leaning against each other, so the extensions between the top edges or bottom edges can be observed, as well as between the respective peripheral fillets.

Fig. 4 is a sectional side view, showing an amplified detail of the new disposition introduced in the can, providing spacing and protection of the edges and peripheral fillets of the can against friction and supports;

Fig. 5 is a side view showing, for comparison, two cans and their respective lids of the prior-art type, leaning against each other, enabling the

observation of the undesirable effects of both uplifting and overlapping of the peripheral fillets placed on the edge of the lid.

Particularly describing such an invention and, in accordance to what was shown on the drawings that are attached to this descriptive report, such mentioned improvements provide a new disposition to the superior part of the body of the can which, in its original and known form, is the object of Brazilian Patent BR N° 9203029-7 of the same inventor and comprises an overall cylindrical body (1), a nailed bottom wall (2) and, on the superior part, close to the aperture, a roundish fillet (3) outwardly projected, this one being susceptible to receiving a non-nailed metallic, easy-opening lid formed by a circular panel (4), with ascendant edge (5), where, on its internal surface, is placed a seaming gasket (6) and, in the middle of the panel, a circular basin-shaped depression (7), with a central hollow (8) which is sealed by a resinous, thermoplastic, detachable sealing wax (9). Such a lid is the object of Brazilian Patent N° 9103896-0 of the same inventor.

This kind of lid is provided, on the inferior and peripheral edge of the border or skirt (5), with a narrow and roundish fillet (10), which is meant to facilitate the rising and withdrawal of the lid from its closing position, subsequently to the seal extraction and release of the vacuum, this last one being responsible for securing the can.

In the already known types of these cans, whenever the lid was applied or placed in the closing position - as shown in fig. 5 - the peripheral fillets (10) were kept salient and laterally projecting outwards, in relation to the cylindrical body (1) of the can, in such a way that, whenever the cans were arranged in groups, side by side, these peripheral fillets (10) were submitted to mounting caused by vibrations which caused the accidental opening of the cans.

In accordance with the present improvements and as shown by figs. 1, 3 and 4; a new disposition was given to the superior part of the body of the can, by which was provided enough retraction or retirement of the edge or skirt (5) of

the can and of its respective peripheral fillet (10) in relation to the lateral wall of the cylindrical body (1) of the can, enabling, therefore, that whenever the cans are packed or closely leaning against each other, these peripheral fillets (10) are kept free of overlap and friction and, hence, incapable of mounting or overlapping, thereby preventing the accidental opening of this kind of packing. In other words, this kind of problem is completely solved in force of the present improvements.

It is still important to clarify, by means of a better evaluation of the importance of the present improvements, that this kind of can, the closure of which is obtained by a metallic, non-nailed, easy-opening lid, being retained only by vacuum action without any other mechanical securing means, offers lots of advantages and deserves the preference of the consumers, thanks to the extreme easiness of opening as well as the safety against wounds on the user's hands being recognized as a great evolution in metallic packing.

The vacuum-closure system by metallic, non-nailed, easy-opening lids as the lid in its original and well-known shape, hereto mentioned and presented by the drawings, is not part of the present invention, as long as they comprise the objects of previous patents of the same inventor. In this way, only the introduced improvements are pertinent as an invention, by which the problems concerning the accidental opening of the can were completely eliminated.

CLAIMS

1. A vacuum-closure can having a metallic, non-nailed, easy-opening lid for foodstuff packing, comprising:

a cylindrical body having a nailed bottom wall, a central portion with an outside diameter extending along a length thereof and further having a superior part tapering continuously inwardly from the central portion, said cylindrical body presenting, on a superior part thereof and close to an aperture thereof, a round fillet turned outwardly, said superior part connecting said fillet with the central portion of the body; and

a metallic, easy-opening lid received on said fillet of said cylindrical body, said lid including a circular panel with a short descending skirt having a peripheral fillet and having on an internal surface thereof a sealing gasket, and in a middle of said panel a circular basin-shaped depression with a central hollow closed by a resinous, detachable seal; said skirt of said lid, said peripheral fillet of said skirt and said superior part being inwardly spaced from the outside diameter of the central portion of said cylindrical body.

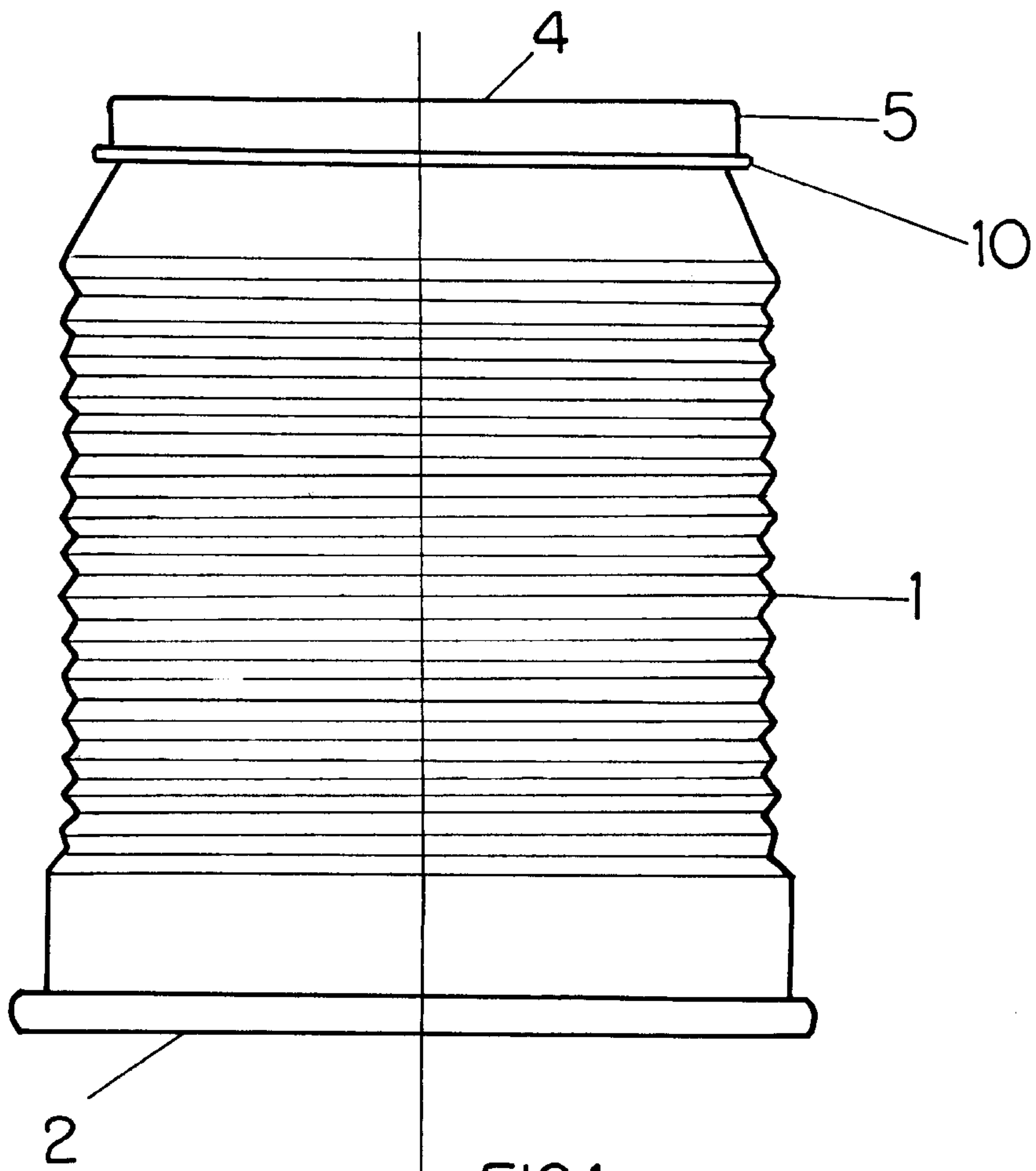

FIG 1

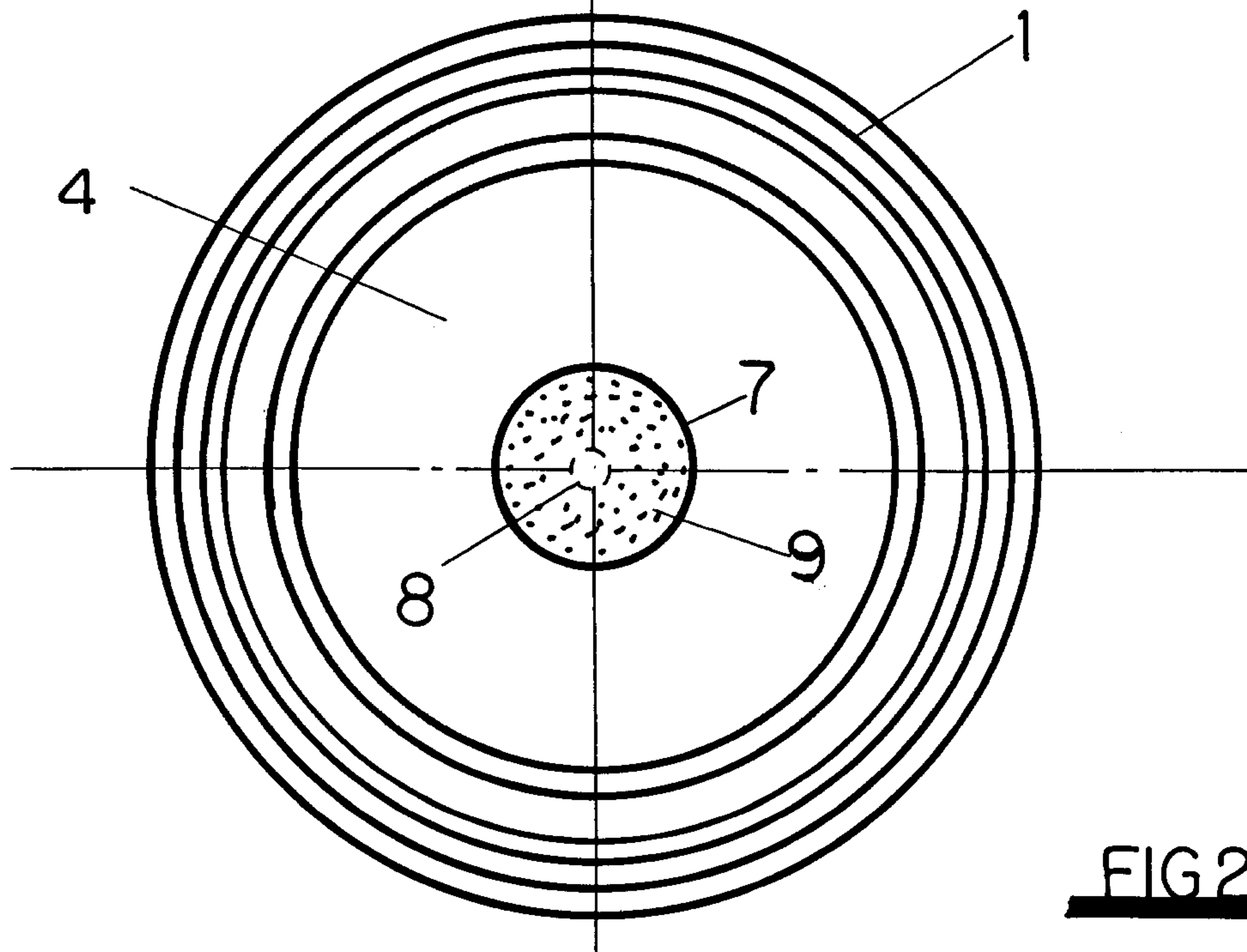

FIG 2

Andrew Sage Dubue & Herbert Walker

2194344

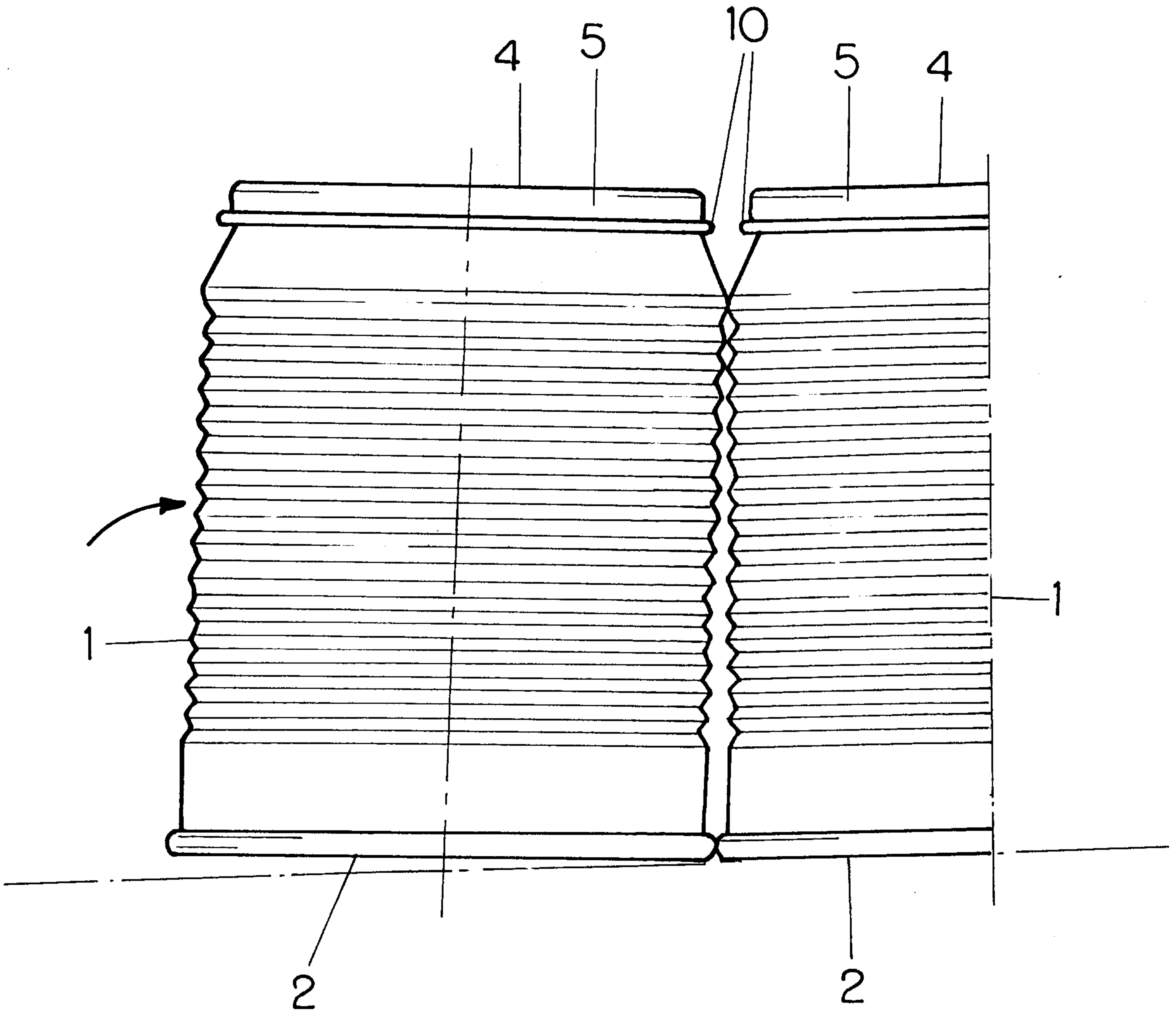

FIG 3

Goodman Page Dubuc & Hartman Walker

2194344

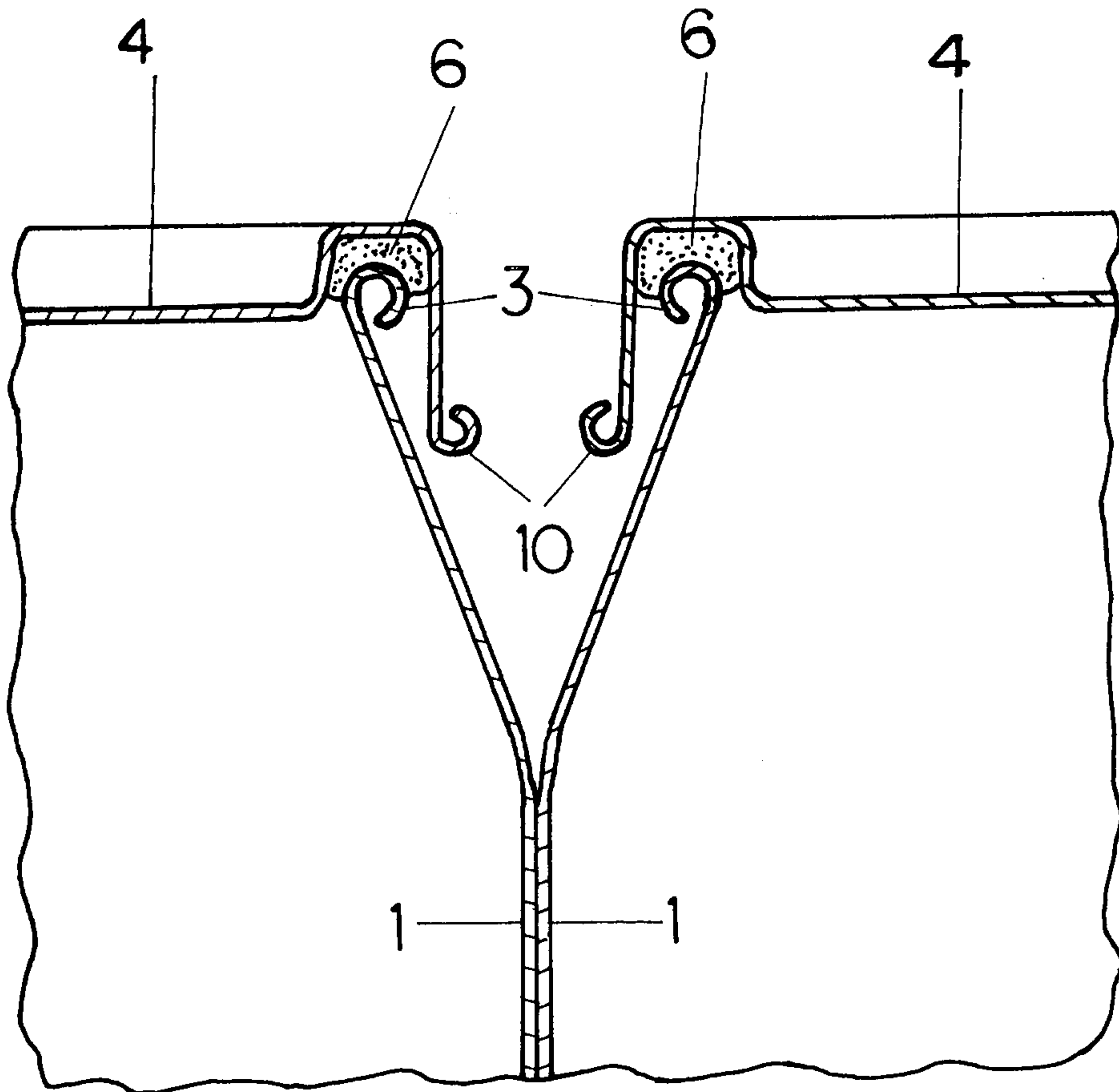

FIG4

Andrew Sage Dubuc & Hester Walker

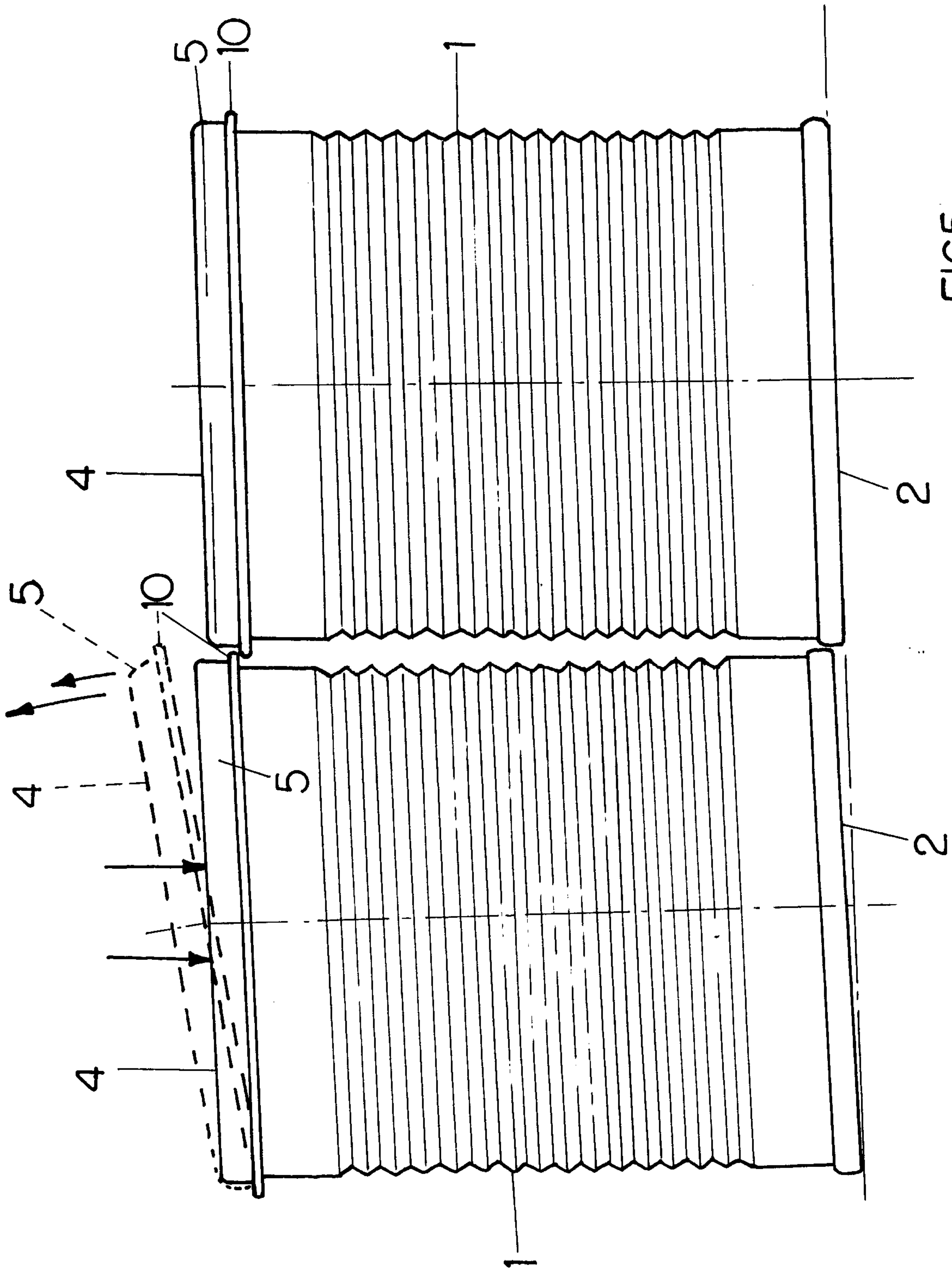

FIG 5

Anderson Shoe Outfit & Hardware Walker

