

H. F. & G. S. Snyder,

2. Sheets, Sheet. 1.

Saw Mill.

No. 101,531.

Patented Apr. 5. 1870.

Fig. 1.

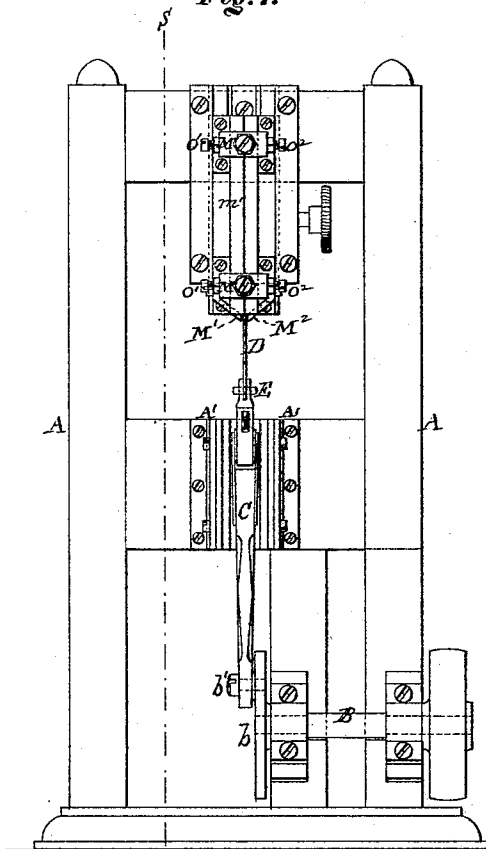

Fig. 3.

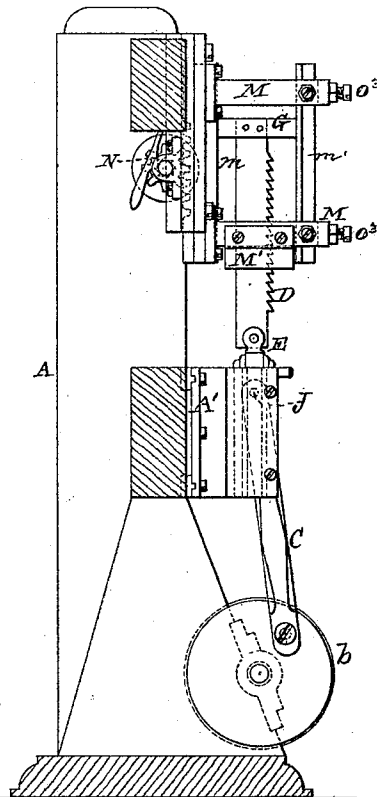
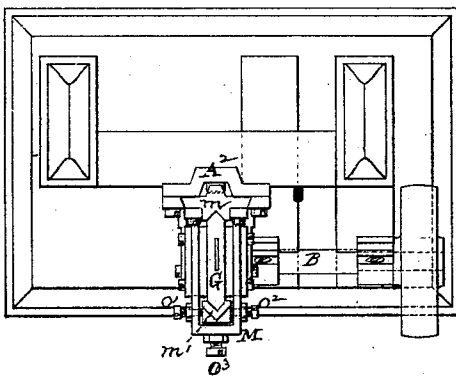

Fig. 2.



Inventors.

H. F. Snyder  
 G. S. Snyder  
 by their attorney, J. S. Wilson

Witnesses.

C. C. Livings  
 J. S. Wilson

H. P. & G. S. Snyder,

Saw Mill.

No. 10,531.

Patented Apr. 5, 1870.

Fig. 4.

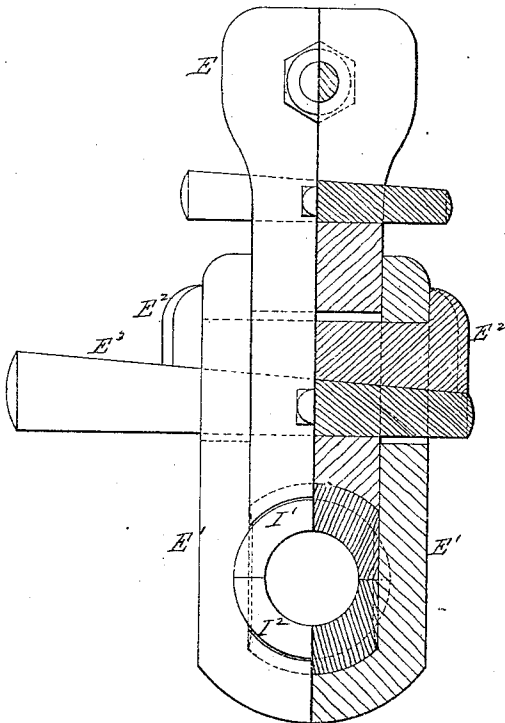

Fig. 5.

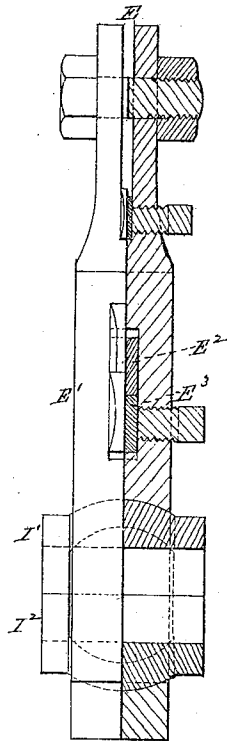

Fig. 6.

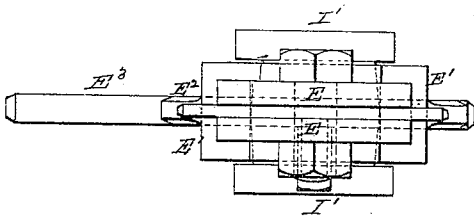
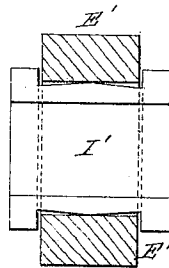

Fig. 7.



Witnesses.

*C. C. Livings*  
*Wm. C. Guy*

Inventors.

*H. P. Snyder*  
*G. S. Snyder*  
 by their attorney, *J. D. Peterson*

# United States Patent Office.

HENRY F. SNYDER AND GEORGE S. SNYDER, OF WILLIAMSPORT, PENNSYLVANIA.

Letters Patent No. 101,531, dated April 5, 1870.

## IMPROVEMENT IN SAW-MILLS.

The Schedule referred to in these Letters Patent and making part of the same.

To all whom it may concern :

Be it known that we, HENRY F. SNYDER and GEORGE S. SNYDER, of Williamsport, in the county of Lycoming and State of Pennsylvania, have invented certain new and useful Improvements in Muley-Saw Hangings; and we do hereby declare that the following is a full and exact description thereof.

What is known as a muley-saw is mounted independently of any gate or stretching-frame. It supports itself by its own stiffness. It is capable of running much quicker than the ponderous gate-saws. Its lower end is connected to a pitman, which is operated by a crank below. Both ends are carried in slides, which are nearly vertical.

Our invention provides very efficient means for swiveling the saw around, or turning it on a vertical axis with great delicacy within narrow limits. It aids very greatly in causing the saw to run true. Any slight inequality in the filing on opposite sides of the saw, or even a dulling of one side more than another by contact with grit, metal, or even a very hard knot, may give a saw which has been previously well adjusted a tendency to run to one side or the other. In such case we swivel the saw around sufficiently to balance such tendency.

The accompanying drawings form a part of this specification.

Figure 1 is a front view of the saw and the connected mechanism.

Figure 2 is a plan view of the entire apparatus.

Figure 3 is a vertical section on the line *s s* in fig. 1.

The carriage for moving the log and the means for operating it are omitted as non-essential. They may be of any approved construction.

The additional figures represent the stirrup and swiveling connection at the base of the saw on a larger scale.

Figure 4 is a side view, half in section.

Figure 5 is an edge view, half in section.

Figure 6 is a view from above.

Figure 7 is a horizontal section.

Similar letters of reference indicate like parts in all the figures.

The drawings represent the novel parts with so much of the other parts as is necessary to indicate their connection thereto. All the parts not here represented may be of the ordinary approved construction.

A is a stout frame-work of wood.

B is a rapidly-revolving shaft, driven by a steam-engine or other suitable power.

*b'* is a crank-pin, fixed in the slot in a face-plate, *b*, which is carried on the shaft B.

C is a connecting-rod, which communicates a recip-

rocating motion to the saw from the rotation of the crank-pin *b'*.

The saw is represented by D, and may be of any approved breadth, thickness, style of teeth, &c. Its lower end is held in a stirrup, E, and its upper end between guide-blocks, as represented by G, which, together serve as a cross-head.

Directing our attention first to the lower end of the saw, we provide means for swiveling the saw D and the connecting stirrup E around on a lower cross-head, and for adjusting it very firmly at various angles. The construction at this point is shown very clearly in figs. 4 and 7.

The lower end of the stirrup E is formed with a strap, *E'*, operated by a gib and key, *E<sup>2</sup> E<sup>3</sup>*, and embraces a brass box, formed in two parts, *I<sup>1</sup> I<sup>2</sup>*, which, in turn, embrace the pin J, which extends through suitable bearings in the upper end of the pitman C, and is guided by blocks, which run in very firmly fixed vertical guides *A<sup>1</sup>*. These guides *A<sup>1</sup>* may be formed of cast-iron, and bolted immovably upon the framing A.

The pin J and the entire cross-head of which this pin forms a prominent part, is guided by the slots *A<sup>1</sup>*, and cannot swivel, but is compelled to simply move up and down by the rotation of the crank-pin *b'*.

The upper and lower faces of the boxes *I<sup>1</sup> I<sup>2</sup>* are spherical. The adjacent surfaces of the stirrup E are correspondingly hollowed. By loosening the key *E<sup>3</sup>*, the force with which the boxes *I<sup>1</sup> I<sup>2</sup>* are held within the stirrup is reduced. In this condition the stirrup may be taken hold of by a screw-wrench or other suitable device, and turned a little to the right or the left; in other words, the stirrup may be swiveled around to a slight degree, turning on the boxes *I<sup>1</sup> I<sup>2</sup>*. When it has been turned just to a sufficient extent, the key *E<sup>3</sup>* is again tightened, and this compels the stirrup to again take hold very firmly and rigidly on the boxes *I<sup>1</sup> I<sup>2</sup>*, but in the new position.

It will be observed that the boxes *I<sup>1</sup> I<sup>2</sup>* are so constructed that there is liberty to turn to a small extent within the strap *E'*, as shown in fig. 7; that is to say, the flanges on the boxes are not matched tightly on this strap, but each made to fit a little loose.

Furthermore, it will be seen, by observing attentively the form of the boxes, that they fill the strap *E'* only along the middle line of said strap; in other words, there is a slight bevel on the faces of the boxes presented to the interior of the strap at the front and rear. It follows that the boxes are held very efficiently against forward or backward motion within the strap by a direct contact therewith along the middle line, but there is liberty to swivel around within the strap to as great an extent as is ever required in practice.

We employ entirely different means for swiveling

around the upper end of the saw. Here we leave the saw immovably connected to the guide-blocks, and shift the movable guides, in which the latter runs. We will describe this part of the mechanism in detail.

A<sup>2</sup> is a stout casting or bed-plate, which forms a dovetailed slide or guide for the movable housing M. This latter is cast with a stout rack on its rear face, which receives the teeth and pinion N, operated by a hand-wheel or other suitable means, so that the housing M may be raised or lowered bodily at will within wide limits.

The housing M carries two slides, *m* and *m'*. The rear slide *m* is fixed in the housing, but the front slide *m'* is adjustable laterally by screws O<sup>1</sup> O<sup>2</sup> O<sup>3</sup>. Both the slides *m* and *m'* with the screws and the other attachments are raised and lowered together with the housing. The importance of providing a movable housing, which can be raised and lowered, is so well understood by sawyers as to require no explanation. We employ all the ordinary provisions for sustaining and guiding the saw by means of this housing, and for guiding the saw at the extreme lower edge of the housing, by blocks of hard and well-oiled wood, as indicated by M<sup>1</sup> M<sup>2</sup>, as will be readily understood.

Now to swivel around the upper end of the saw, we slacken the screws O<sup>1</sup> and tighten the screws O<sup>2</sup> or the reverse. The effect is to move the slide *m'* to one side or the other. We provide jam-nuts on all the screws, to insure their remaining very firmly in position.

The front screws O<sup>3</sup> perform the same function to drive back the slide *m'* sufficiently to compensate for the wear of the slide and guide-blocks.

Though we have spoken of the slides as vertical, it will be obvious that they can work with some success in various degrees of inclinations, and in such case the

swiveling of the saw would not be around a strictly vertical axis.

When the saw is to be used for a considerable period on small lumber, we lower the entire housing M by turning a wheel, N, and when it is to be used on large lumber, it will be necessary to correspondingly raise the housing and its attachments. The point desired is to keep the side bearing blocks, which guide the saw laterally, as near the upper surface of the lumber to be treated as practicable. We change the stroke of the saw at will by shifting the crank-pin *b'* in a slot in which it is fixed.

We do not confine ourselves to the use of all the details of the mechanism in the precise form and proportion here shown; but

We claim—

1. In combination with the saw D and cross-head J, as specified, the swiveling boxes I<sup>1</sup> I<sup>2</sup>, fitting in corresponding bearings in the gripping parts E E<sup>1</sup>, and provided with the key E<sup>2</sup>, or equivalent means for tightening and liberating their hold, in the manner and for the purposes herein set forth.

2. In combination, the within described adjustable swiveling connection between the boxes I<sup>1</sup> I<sup>2</sup> and the gripping parts E E<sup>1</sup> at the lower end, and the movable slides, which allow of correspondingly swiveling the saw at the upper end, when arranged for joint operation, substantially as and for the purposes herein set forth.

In testimony whereof we have hereunto set our names in presence of two subscribing witnesses.

H. F. SNYDER.  
G. S. SNYDER.

Witnesses:

J. D. SNYDER,  
JNO. G. HEISER.