



Nov. 11, 1947.

J. H. MILLS ET AL

2,430,645

DECOY DUCK

Filed Nov. 15, 1945

2 Sheets-Sheet 2

Fig. 6

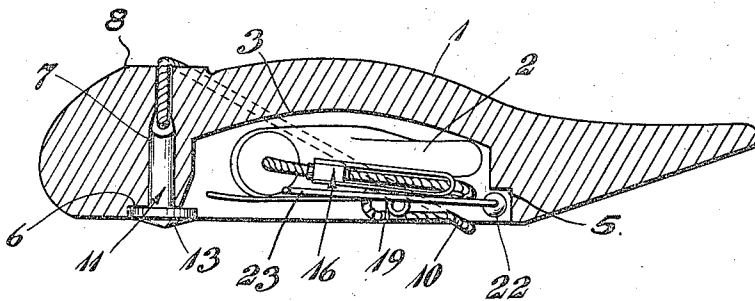

Fig. 7

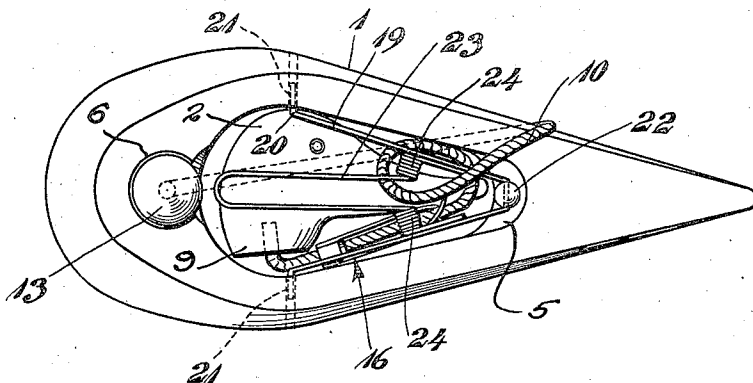
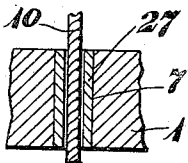

Fig. 8



Inventors

*John H. Mills*  
*Robert L. Tanner Jr.*

By

*Clarence A. O'Brien*  
*and Harvey B. Jacobson*  
Attorneys

# UNITED STATES PATENT OFFICE

2,430,645

## DECOY DUCK

John H. Mills and Robert L. Tanner, Jr.,  
Rockport, Tex.

Application November 15, 1945, Serial No. 628,726

3 Claims. (Cl. 43-3)

**1**  
Our invention relates to improvements in decoy ducks, the primary object in view being to provide an inexpensive, efficient decoy in the form of a duck equipped with an anchor line and with counterbalance means for stabilizing the same in the water against rolling and pitching, and which is particularly designed for storing away within the body of the decoy all of the other parts to thereby form a compact, readily portable article with the stored parts readily available for use.

Other and subordinate objects also comprehended by our invention, together with the precise nature of our improvements and the manifold advantages thereof, will become readily apparent when the succeeding description and claims are read with reference to the drawings accompanying and forming a part of this specification.

In said drawings:

Figure 1 is a view in side elevation of our improved decoy duck in a preferred embodiment thereof,

Figure 2 is a view in bottom plan, with the stabilizer member and keeper swung into the cavity in the body,

Figure 3 is a detail view in side elevation of the combined head and neck part with a part of the anchor cable and the expander on said cable,

Figure 4 is a detail view in side elevation of the anchor,

Figure 5 is a similar view of the expander,

Figure 6 is a view in longitudinal section of the decoy duck showing the manner in which the parts are stored,

Figure 7 is a view in bottom plan of the decoy duck with the parts stored, and

Figure 8 is a detail view of a modification of one of the parts of the invention.

Referring to the drawings by numerals, our improved decoy duck, as shown, comprises a body 1, of the usual shape, and a separate combined head and neck part 2. The body 1 is provided, in the bottom thereof, with a storage cavity 3, preferably oval in shape, with rearwardly tapering side walls 4, and which is centered in the median plane of the body 1 in the rear of the combined head and neck part 2. The rear end of the storage cavity 3 is stepped to form a shallow recess 5 providing a stop for a purpose presently seen. At the front end of the storage cavity 3, a seat 6 is formed in the bottom of the body 1, around a vertical through bore 7 in said body. At the upper end of the bore 7

**2**  
a flat, concentric seat 8 is formed on the body 1 around said bore 7 for the head and neck part 2.

The head and neck part 8 embodies a neck portion 9 flat bottomed to engage the seat 8. An anchor cable 10, preferably rope, has one end suitably socketed in and fastened to said neck portion 9. The anchor cable 10 is extended through the bore 7 and seat 6 and has fastened to the other end thereof a weight-type anchor 11. The anchor 11 embodies a short shank 12 adapted to slidably fit in the bore 7, a flat faced circular head 13 adapted to fit into seat 6, and an end eye 14 through which the anchor cable 10 is looped, as at 15. The anchor cable 10 is adapted to slide freely through the bore 7.

An expander 16 is provided on the anchor cable 10 for insertion into the bore 7 to maintain the neck portion 9 seated on the seat 8 by frictionally retaining in the bore 7 the end of the anchor cable 10 to which the head and neck part 2 is attached. The expander 16 comprises a sleeve 17 crimped around the anchor cable 10 with resilient wire fingers 18 extending therefrom along said anchor cable and frictionally fitting in said bore 7.

As will be seen, by pulling the expander 16 into the bore 7 from the top of the body 1, the head and neck part 2 may be seated on the seat 8. By pulling on the head and neck part 2, the expander 16 may be pulled upwardly out of said bore 7 and the anchor cable 10 pulled through said bore 7 until the shank 12 of the anchor 11 is slid into said bore 7 with the head 13 engaged in the seat 6. The anchor cable 10 may then be passed rearwardly over one side of the body 1 and coiled and stored in the cavity 3, together with the neck and head part 2 and the expander 16, all as shown in Figures 6 and 7.

A V-shaped stabilizer 19 is swingably mounted in the sides 4 of the cavity 3 by means of right-angled trunnion ends 20 journaled in lateral bores 21 in said sides adjacent to the front end of the cavity 3. The stabilizer 19 has the apex portion thereof counterweighted, as at 22, and is adapted to be swung into the cavity 3 with its counterweighted end 22 disposed in the recess 5 against the stop formed by said recess.

A U-shaped spring keeper 23 is suitably connected by lateral coil spring ends 24 with straight terminals 25 thereon to the sides of the stabilizer 19 and to normally assume coplanar relation with respect to said stabilizer, and extend forwardly of the stabilizer when the latter is swung into the cavity 3.

In using the described decoy, the anchor cable

3

10 is pulled downwardly through the bore 7 until the expander 16 is pulled into said bore and the neck portion 9 of the head and neck part 2 is seated on the seat 8, all as previously described. The anchor cable 10, with the anchor 11, may then be used to anchor the body 1 in the water. When the body 1 is placed in the water, the stabilizer 19 swings, by gravity, into depending position, as shown in Figure 1, and stabilizes said body 1 against rolling laterally and upsetting. When the anchor cable 10, and the combined head and neck part 2, together with the expander 16, are stored in the storage cavity 3, the stabilizer may be swung into said storage cavity, in the manner already described, and as shown in broken lines in Figure 1, with the keeper 23 yieldingly bearing against the coiled anchor cable 10 and the head and neck part 2, as shown in full lines in Figures 7 and 8. Thus the stored parts are held in the storage cavity 3 and said parts prevent the stabilizer 19 and the keeper 23 from swinging out of said storage cavity. If desired, the right end of the keeper 23 may be curved, as at 26, to frictionally interlock with the bottom of the storage cavity 3, as shown by broken lines in Figure 1, when said stabilizer swings downwardly. Thus said stabilizer 19 yieldingly locks against swinging out of the perpendicular when the body 1 is in the water. This provides for stabilizing the body 1 against undue pitching.

It is preferable that the body 1, together with the combined head and neck part 2, be formed of a suitable buoyant, light weight, inexpensive plastic.

A suitable bushing 27 may be provided for the bore 7 to take up wear therein, and similar bushings, not shown, for the same purpose for the bores 21.

The foregoing will, it is believed, suffice to impart a clear understanding of our invention without further explanation.

Manifestly, the invention, as described, is susceptible of modification without departing from the inventive concept, and right is herein reserved to such modifications as fall within the scope of the appended claims.

What we claim is:

1. In a decoy duck, a body having a bottom storage cavity therein and an upper end seat thereon, a combined head and neck part adapted to engage said seat, a cable attached at one end

4

to said part and slidably extended through said body for pulling therethrough in one direction to engage said part with said seat and for pulling in the opposite direction to provide for removal of said part from the seat and storing of said part, together with a section of the cable, in said storage cavity, and means to retain said cable section and part in said cavity and swingable into the cavity to confine said cable section and said part between said means and the bottom of said cavity, said means comprising a stabilizer for the body swingable out of said cavity into stabilizing position to permit said cable section and said part to be stored in said cavity, and a resilient keeper on said stabilizer for bearing against said part when stored in said cavity to yieldingly prevent the stabilizer from being swung out of said cavity.

2. In a decoy duck, a body having a vertical through front end bore therein, a combined separate head and neck part adapted to seat on said body in upright position, an anchor cable attached at one end to said part and slidably extended through said bore for pulling therethrough to seat said part on said body, and an expander on said cable for pulling into said bore when said part is seated, and frictionally fitting in the bore to maintain said part seated.

3. In a decoy duck, a body having a vertical through front end bore therein, a combined separate head and neck part adapted to seat on said body in upright position, an anchor cable attached at one end to said part and slidably extended through said bore for pulling therethrough to seat said part on said body, and an expander on said cable for pulling into said bore when said part is seated, and frictionally fitting in the bore to maintain said part seated, said cable having an anchor on the other end thereof.

JOHN H. MILLS.

ROBERT L. TANNER, Jr.

#### REFERENCES CITED

The following references are of record in the file of this patent:

#### UNITED STATES PATENTS

Number	Name	Date
1,486,329	George	Mar. 11, 1924
1,923,442	Kilgore	Aug. 22, 1933
2,037,052	Wittman	Apr. 12, 1936