



- (51) International Patent Classification:
B01L 3/00 (2006.01)
- (21) International Application Number:
PCT/US2012/034506
- (22) International Filing Date:
20 April 2012 (20.04.2012)
- (25) Filing Language: English
- (26) Publication Language: English
- (30) Priority Data:
61/477,785 21 April 2011 (21.04.2011) US
- (71) Applicant (for all designated States except US):
STRECK, INC. [US/US]; 7002 South 109th Street, Lavista, NE 68182 (US).
- (72) Inventors; and
- (75) Inventors/Applicants (for US only): **VILJOEN, Hendrik, J.** [US/US]; 4744 Birch Hollow Drive, Lincoln, NE 68516 (US). **WHITNEY, Scott, E.** [US/US]; 5519 West Chancery Road, Lincoln, NE 68521 (US). **TERMAAT, Joel, R.**

[US/US]; 2816 Shelley Circle, Lincoln, NE 68516 (US). **KREIFELS, Matthew, Robert**; 15224 Spencer Street, Omaha, NE 68116 (US).

(74) Agents: **PURSLEY, Kristen** et al.; Dobrusin & Thennisch PC, 29 W. Lawrence Street, Suite 210, Pontiac, MI 48342 (US).

(81) Designated States (unless otherwise indicated, for every kind of national protection available): AE, AG, AL, AM, AO, AT, AU, AZ, BA, BB, BG, BH, BR, BW, BY, BZ, CA, CH, CL, CN, CO, CR, CU, CZ, DE, DK, DM, DO, DZ, EC, EE, EG, ES, FI, GB, GD, GE, GH, GM, GT, HN, HR, HU, ID, IL, IN, IS, JP, KE, KG, KM, KN, KP, KR, KZ, LA, LC, LK, LR, LS, LT, LU, LY, MA, MD, ME, MG, MK, MN, MW, MX, MY, MZ, NA, NG, NI, NO, NZ, OM, PE, PG, PH, PL, PT, QA, RO, RS, RU, RW, SC, SD, SE, SG, SK, SL, SM, ST, SV, SY, TH, TJ, TM, TN, TR, TT, TZ, UA, UG, US, UZ, VC, VN, ZA, ZM, ZW.

(84) Designated States (unless otherwise indicated, for every kind of regional protection available): ARIPO (BW, GH, GM, KE, LR, LS, MW, MZ, NA, RW, SD, SL, SZ, TZ,

[Continued on next page]

(54) Title: IMPROVED SAMPLE TUBE HAVING PARTICULAR UTILITY FOR NUCLEIC ACID AMPLIFICATION

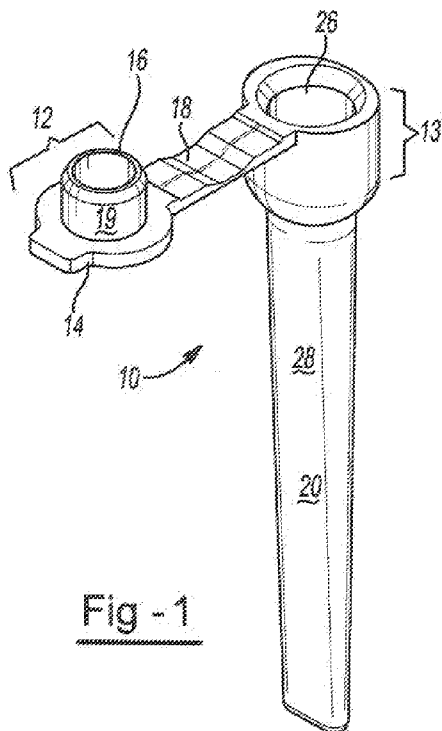

Fig - 1

(57) Abstract: An improved tube (10) including a closure portion (12), a strap (18) integrally connected to the closure portion (12) and being configured for defining a living hinge, a body portion (20) having a longitudinal axis and an outer wall generally circumscribing the longitudinal axis, and being integrally and hingedly connected with the closure portion (12) by way of the strap (18), the body portion (20) including a head portion (13) that has an opening (26) through which a sample is dispensed, and a sample portion (28) having a first outer wall dimension (OWD1) and including a closed distal end (30) and a wall structure (32) that includes an outer wall (34) and an inner wall structure (36) that defines a hollow cavity (38) within which the sample resides as a sample volume after is dispensed through the head portion (13), the sample portion (28) being generally elongated along the longitudinal axis and being configured for elastic deformation along a portion of its length, including in a direction that is generally transverse to the longitudinal axis so that at least a portion of the wall structure compressively and resiliently deforms and engages a wall defining an opening in a sample block of a polymerase chain reaction amplification device, and the first outer wall dimension (OWD1) of the sample portion (28) reduces to a smaller second outer wall dimension (OWD2).



UG, ZM, ZW), Eurasian (AM, AZ, BY, KG, KZ, MD, RU, TJ, TM), European (AL, AT, BE, BG, CH, CY, CZ, DE, DK, EE, ES, FI, FR, GB, GR, HR, HU, IE, IS, IT, LT, LU, LV, MC, MK, MT, NL, NO, PL, PT, RO, RS, SE, SI, SK, SM, TR), OAPI (BF, BJ, CF, CG, CI, CM, GA, GN, GQ, GW, ML, MR, NE, SN, TD, TG).

Published:

- *with international search report (Art. 21(3))*
- *before the expiration of the time limit for amending the claims and to be republished in the event of receipt of amendments (Rule 48.2(h))*

IMPROVED SAMPLE TUBE HAVING PARTICULAR UTILITY FOR NUCLEIC ACID AMPLIFICATION

Cross Reference to Related Application

[001] This application claims priority to United States Provisional Application Serial Number 61/477,785, filed April 21, 2011, the entire contents thereof are incorporated herein by reference.

FIELD OF THE INVENTION

[002] The present invention relates generally to containers, and more particularly to unique resilient polymeric sample tubes for nucleic acid amplification.

BACKGROUND OF THE INVENTION

[003] There is a need for sample holders that are thermally efficient in the manner in which heat is delivered to a contained sample, removed from a contained sample, or both. This is particularly acute in the field of polymerase chain reaction amplification of nucleic acid (e.g., DNA amplification). In such applications, samples are exposed to a dynamic heating and cooling protocol. Successful amplification often relies upon time dependent heat transfer. As a result, the efficiency of such operations can be limited when the mass, volume, or length of heat transfer of a sample is such that it impedes heat transfer within it, and to and from it.

[004] One approach to sample tubes for amplification of nucleic acid has been to employ glass capillaries. While useful, the risk of breakage during use and the inability to deform such glass tubes during an amplification process make the use of glass capillaries an undesirable option. Another approach has been to employ polymeric sample vessels. However, the polymeric material may not provide sufficient heat transfer to substances within the tubes and may also fail to provide sufficient elasticity to be compressed as necessary during the

amplification process. Examples of such polymeric and glass sample holders include those in U.S. Patent Nos. 5,225,165; 5,353,186; 5,571,479; 5,604,101; 5,721,136; 5,863,791; 5,958,349; 6,015,534; 6,159,727; 6,312,886; 6,783,025; 7,255,833; and 7,749,452.

[005] There is thus a need for an improved polymeric sample tube that provides for both sufficient heat transfer and sufficient elasticity for use in amplification processes that require compression of the tube during use.

SUMMARY OF THE INVENTION

[006] The present invention meets one or more of the above needs by providing in an improved tube, and particularly a miniature sample tube that comprises a closure portion (which itself may include a tab portion, and an adjoining plug portion), a strap integrally connected to the closure portion and being configured for defining a living hinge. The sample tube may further include a body portion having a longitudinal axis and an outer wall generally circumscribing the longitudinal axis, and being integrally and hingedly connected with the closure portion by way of the strap. The body portion may include a head portion that has an opening through which a sample is received and/or dispensed, and a sample portion having a first outer wall dimension and including a closed distal end. The sample portion may also include a wall structure that includes an outer wall and an inner wall structure that defines a hollow cavity within which the sample resides as a sample volume after it is received through the head portion. The closed-ended hollow sample portion may be generally elongated along the longitudinal axis and may be configured for elastic deformation along at least a portion of its length. The sample portion may be deformable in a direction that is generally transverse to the longitudinal axis so that at least a portion of the wall structure compressively and resiliently deforms and engages a wall defining an opening in a sample block of a polymerase chain reaction amplification device. Upon deformation, the first outer wall dimension of the sample portion may be reduced to a smaller second outer wall dimension.

[007] As will be seen, such a tube offers a unique approach to handling a material, and especially a biological sample. It is seen that, particularly as employed for preparing biological samples for nucleic acid amplification, the material (e.g., the biological sample) can readily be introduced into the tube without significant surface resistance, while then allowing the heat exchange characteristics of the volume of the material to be altered by manipulation of the tube relative to a sample block of a thermocycler. That is, the mere insertion of the tube into such a sample block can cause the tube to deform elastically, so that the overall thickness of the sample material that is heated becomes thinner, and more efficient for heat exchange (as compared with its original volume).

DESCRIPTION OF THE DRAWINGS

[008] Figure 1 is a perspective view of an illustrative example of the tube of the present invention.

[009] Figure 2a is a side profile view of the tube of Fig. 1.

[0010] Figure 2b is a front view of the tube of Fig. 1.

[0011] Figure 3 is a top-down view of the tube of Fig. 1 showing the major and minor diameters within the tube.

[0012] Figure 4a is a cross-sectional view of an illustrative example of a sample block showing the tube of Fig. 1 partially inserted into a sample block opening.

[0013] Figure 4b is a cross-sectional view of the sample block of Fig. 4A showing the tube of Fig. 1 fully inserted into a sample block opening.

[0014] Figure 5 is a perspective view of an illustrative example of the tube of the present invention.

[0015] Figure 6 is a side profile view of the tube of Fig. 5.

[0016] Figure 7 is a perspective view of an illustrative example of the tube of the present invention.

[0017] Figure 8 is a side profile view of the tube of Fig. 7.

[0018] Figure 9 is a top down view of the tube of Fig. 5.

[0019] Figure 10 is a perspective view of the tube of Fig. 5.

- [0020] Figure 11 is a side profile view of the tube of Fig. 5.
- [0021] Figure 12 is a front view of the tube of Fig. 5.
- [0022] Figure 13 is a side profile view of the tube of Fig. 1.
- [0023] Figure 14 is a front view of the tube of Fig. 1.
- [0024] Figure 15 is a perspective view of the tube of Fig. 1.
- [0025] Figure 16 is a front view of the tube of Fig. 7.
- [0026] Figure 17 is a rear view of the tube of Fig. 7.
- [0027] Figure 18 is a perspective view of the tube of Fig. 7.
- [0028] Figure 19 is a perspective view of an illustrative example of a tube including a stop feature in accordance with the present teachings.
- [0029] Figure 20 is a front view of the tube of Fig. 19.
- [0030] Figure 21 is a side profile view of the tube of Fig. 19.
- [0031] Figure 22 is a top down view of the tube of Fig. 19.

DETAILED DESCRIPTION

[0032] The present teachings pertain generally to an improved tube structure that exhibits relatively good heat exchange performance. The tube structure thus finds particularly attractive utility for polymerase chain reaction nucleic acid amplification protocols that employ repeated thermal cycling between hotter and cooler temperatures. The tube structure employs a relatively thin wall sample holding portion. In certain preferred aspects of the teachings, the tube structure employs a resiliently deformable structure that allows the tube to achieve intimate thermal communication (e.g., direct contacting communication) with a sample block that is the object of rapid heating and cooling.

[0033] Accordingly, in one aspect of the teachings there is contemplated a tube, and particularly a miniature tube for holding relatively small volumes of a material (such as no more than about .2 milliliters (ml) of a fluidic material (e.g., a capacity of no more than about .18 ml)), which makes the tube particularly attractive for use as a sample tube, and more specifically a biological sample tube. The tube may be configured to include a closure portion (which itself may include a tab portion, and an adjoining plug portion), a strap integrally connected

to the closure portion and being configured for defining a living hinge, and a body portion. The body portion desirably has a longitudinal axis and an outer wall generally circumscribing the longitudinal axis. The body portion may be integrally and hingedly connected with the closure portion by way of the strap. The body portion may include a head portion that has an opening through which a sample is dispensed. The head portion may adjoin a sample portion of the body portion at a juncture (e.g., a neck that has a continuously variable slope around its circumference). The sample portion may have a first outer wall dimension and may include a closed distal end and a wall structure that includes an outer wall and an inner wall structure that defines a hollow cavity within which the sample (or any other material) resides as a sample volume after it is received through the head portion. The closed-ended hollow sample portion may be generally elongated along the longitudinal axis and desirably will be configured for elastic deformation along at least a portion of its length, including in a direction that is generally transverse to the longitudinal axis so that at least a portion of the wall structure compressively and resiliently deforms and engages a wall defining an opening in a sample block of a polymerase chain reaction amplification device. Upon such deformation the first outer wall dimension of the sample portion may be reduced (e.g., with a sample located therein) to a smaller second outer wall dimension.

[0034] The head portion may be dimensioned for frictionally engaging the closure portion. For example, the head portion may be dimensioned for frictionally engaging the closure portion and engaging the closure portion by way of a snap-fit or friction fit. The closure portion may be separately formed from the tube and/or separately attached to the tube. The head portion may be generally cylindrical. The head portion may be circular in shape or may be generally oval in shape. It may be generally tubular. It may have a substantially constant wall thickness along its length, about its circumference, or both. The head portion may have a generally circular transverse cross-section along its length that has an inner diameter of about 3 to about 4 mm. The head portion may have a generally oval transverse cross-section along its length that has an inner

diameter of about 3 to about 4 mm. The head portion may have a generally circular outer diameter. The head portion may have a generally oval outer diameter. It may have an outer diameter of less than about 7mm (e.g., about 5.5 to about 6.5 mm). The head portion may be formed for pipette loading. The head portion may be formed so that it has sufficient space to receive air pressure formed upon compression of the sample portion of the tube. The head portion may be located adjacent an intermediate portion (e.g., a juncture).

[0035] The intermediate portion may be located between the head portion and sample portion. The diameter of the tube may increase in moving from the sample portion to the head portion such that the intermediate portion comprises the portion of the tube where the diameter expands rapidly. The intermediate portion may have a continuously variable slope around its circumference. The intermediate portion may have a constant around its circumference. The intermediate portion may define a neck having a tapered wall of one or more slopes as evidenced by multiple angles relative to the bottom of the intermediate portion where it intersects with the sample portion. The slopes may gradually and continually vary around the circumference of the neck portion. The intermediate portion may be integrally formed with the sample portion and head portion and may also include a smooth surface with no attachments or extensions.

[0036] Alternatively, the intermediate portion may be formed so that at least a portion of the tube is prevented from entering an opening in a sample block of a thermocycler. More specifically, the intermediate portion may define a neck having a diameter that exceeds the diameter of the sample portion so that the neck is prevented from entering an opening in a sample block. More specifically, as shown for example in Figs. 19-21, the intermediate portion may thus be formed to include a feature or attachment that acts as a stop to prevent the sample tube from entering into a sample block further than desired.

[0037] The sample portion may have a length that is longer than that of the head portion. For example, the sample portion may have a length that is greater than the length of the head portion by a factor of at least about 6. The length of the sample portion may be at least about 20 mm. For example, it may be about

25 to about 35 mm (e.g., about 30 mm). The sample portion may have a width in an open, non-compressed state, of about 2.0 mm.

[0038] The sample portion, along substantially the entirety of its length, may have a transverse cross-section outer profile that includes a transverse minor axis and a transverse major axis. The sample portion may have an outer profile that tapers along the longitudinal axis so that it narrows as it approaches the closed end of the tube (e.g., the end opposing the head portion). For example, the sample portion may have an outer profile that tapers generally continually along substantially the entirety of the length of the sample portion so that it narrows in at least one axis transverse to the longitudinal axis from a first outer wall dimension to a second outer wall dimension that is less than about one half (e.g., about one third) of the first outer wall dimension as it approaches the closed end of the tube.

[0039] The sample portion may be defined by an interior wall that has a generally oval cross section in a direction transverse to the longitudinal axis, for substantially the entirety of the length of the closed-ended hollow sample portion. By way of example, the sample portion may be defined by an interior wall that has a generally oval cross section that includes a minor axis and a major axis that is generally perpendicular to the minor axis, with each axes being oriented in a direction transverse to the longitudinal axis and having a dimension, for substantially the entirety of the length of the closed-ended hollow sample portion. The ratio of the dimensions of the minor axis to the major axis at a location where the head portion adjoins the sample portion may be about 1:2 to about 1:3.5. The minor axis may have a dimension of about 1 mm at the distal end. The minor axis may have a dimension of about 2 mm along at least a portion of the sample portion.

[0040] Substantially along the length of the sample portion, the tube may have a wall thickness of about 0.05 to about 0.2 mm. The distal end may have a wall thickness that is greater than the wall thickness along the length of the sample portion by an amount of at least about twice. The distal end may have a wall thickness that is greater than the wall thickness along the length of the sample

portion by an amount of about 10 times or less. At about the distal end, the tube may be tapered to a width of about 1.25 mm.

[0041] The outer wall of the sample portion may continuously taper at a substantially constant slope. Such taper may occur along substantially the entire length of the sample portion. The sample portion continuously tapers at a substantially constant slope over a length of about 25 to about 32 mm (e.g., about 30 mm).

[0042] The sample portion may include a generally optically transparent portion so that a reaction taking place within the sample portion can be monitored optically through the closed end. The generally optically transparent portion may be structured and/or function as a lens. The closure portion and/or walls of the tube may be optically clear. The closure portion may be optically clear, or only a portion of the closure portion may be optically clear. The sample tube may be made of a generally optically transparent polymeric material (e.g., polypropylene). The sample tube may be substantially free of any electrically conductive material, including any electrically conductive polymer. By way of example, the sample tube may be made of a polypropylene that is sufficiently optically transparent over at least a portion of its length, so that a reaction taking place within the sample portion can be monitored optically. A region including the distal end may be sufficiently optically transparent, so that a reaction taking place within the sample portion can be monitored optically.

[0043] As can be appreciated, the sample tube portion may thus be configured so that during the compressive engagement an interior volume per unit length of the sample tube portion at the region proximate the distal end does not exceed an interior volume per unit length of the sample tube located more proximate to the head portion. The sample tube may be configured so that, during the compressive engagement, any deflection of the sample portion occurs relative to a generally fixed pivot region. The sample tube may be configured so that, during the compressive engagement, any deflection of the sample portion occurs relative to a generally fixed pivot region and the amount of angular deflection is less than about 45° relative to the longitudinal axis. The sample tube

may be configured so that, during the compressive engagement, any deflection of the sample portion occurs relative to a generally fixed pivot region and the amount of angular deflection is less than about 90° relative to the longitudinal axis. The sample tube may be configured so that, during the compressive engagement, any deflection of the sample portion occurs relative to a generally fixed pivot region and the amount of angular deflection is less than about 15° relative to the longitudinal axis. The sample tube may be configured so that, during the compressive engagement, direct contact between opposing inner wall portions of the sample portion is avoided. Alternatively, during the compressive engagement, direct contact between opposing inner wall portions of the sample portion may occur and may promote sufficient heating and cooling cycles of a sample. The sample tube may be configured so that, during the compressive engagement, the closure remains in a closed and substantially sealed relationship with the head portion.

[0044] The teachings herein also contemplate methods of making a tube. According to one method it is envisioned that the tube is made by a method that includes a step of injection molding a polymeric material into a mold. Another possible method includes a step of fusing two or more pre-formed portions of the tube together to define the tube. The method may include a step of extruding the sample portion and then fusing the extruded sample portion with the head portion. The distal end may also be fused to form the closed distal end. As can be seen, such as when molded, the entire tube may be a unitary molded body that is free of any fusion joint. It is possible, such as when a fusing step is used, that the entire tube may be a unitary body that includes the head portion and the sample portion that include a fusion joint between them.

[0045] The present teachings also contemplate use of a tube as described. For example, the tubes herein may be employed to receive a quantity of a material. The material may be a biological specimen. Thus, it is possible that the tubes herein are employed to receive a sample for nucleic acid (e.g., DNA and/or RNA) amplification. The nucleic acid amplification may be performed in a thermocycler. For example, the tubes herein may be employed to amplify a

sample for nucleic acid amplification in a thermocycler that has a sample block (optionally a solid metal sample block, such as a silver sample block) that includes at least one bore defined by a wall having a generally oval transverse section along at least a portion of its length. An example of one suitable thermocycler is described in commonly owned and co-pending U.S. Application Serial No. 12/918,914. The tubes may be employed in a step of inserting the tubes into a thermal block having one or a plurality of bores therein so that contact with the walls causes the tubes to resiliently deform (such deformation may be temporary or permanent) so that heat exchange within the tube is more efficient than in the original configuration (e.g., prior to deformation) that received the sample.

[0046] Turning now to the drawings to illustrate examples of embodiments of the present teachings. As shown for example in Figs 1 and 2, a sample tube 10 is shown having a closure portion 12 (which itself may include a tab portion 14, and an adjoining plug portion 16). A strap 18 integrally connects to the closure portion 12 and is configured for defining a living hinge. The tube includes a head portion 13 to which the closure portion 12 is attached via the strap 18. In the open position (e.g., when the closure is not located within the head portion), the closure portion and head portion may combine to form a width (W) that includes the combined width of the closure portion 12, strap 18, and head portion 13. The closure portion 12 may have a side wall 19 that matingly engages an inner wall of the head portion 13. The side wall 19 may have a length of about 2.5 mm. The side wall 19 may be slightly angled (e.g., about 2°) relative to the longitudinal axis. An intermediate portion 17 may be located in between the head portion 13 and body portion 28. The intermediate portion 17 may define a neck 15 having a tapered wall of one or more slopes as evidenced by angles (e.g., α_1 , α_2) relative to the bottom of the intermediate portion 17 where it intersects with a sample portion 28. The slopes may gradually and continually vary around the circumference of the neck portion. The body portion 20 has a longitudinal axis (LA) and an outer wall 22 generally circumscribing the longitudinal axis. The body portion 20 is integrally and hingedly connected with the closure portion 12 by way

of the strap 18. The body portion includes the head portion 13 that has an opening 26 through which a sample is dispensed and/or received, and a sample portion 28 having a first outer wall dimension (OWD1) (as shown at Fig 4a). The sample portion includes a closed distal end 30 and a wall structure 32 that includes an outer wall 34 and an inner wall 36 that defines a hollow cavity 38, within which the sample resides as a sample volume after is dispensed through the head portion. As seen, the closed-ended hollow sample portion is generally elongated along the longitudinal axis.

[0047] With reference to Figs. 4a and 4b, it is also seen how at least the sample portion is configured for elastic deformation along a portion of its length. Fig. 4a shows the tube prior to deformation by insertion into a sample block 24, while Fig. 4b shows the tube upon deformation when inserted into the sample block 24. Specifically, Fig. 4b illustrates how, when a force is applied to the tube from a direction that is generally transverse to the longitudinal axis (such as a force realized when inserting such tube into an opening of a sample block 24), at least a portion of the wall structure 32 compressively and resiliently deforms and engages a wall 25 defining the opening in the sample block. The first outer wall dimension of the sample portion reduces to a smaller second outer wall dimension (OWD2). During compression, a first internal diameter (D_1) across the tube may increase, while a second internal diameter (D_2) that lies perpendicular to the first diameter may decrease.

[0048] As seen, the head portion frictionally engages the closure by way of a snap-fit connection structure 40. The head portion may have a substantially constant wall thickness (t_H) along its length, about its circumference, or both. As shown for example in Fig. 3, the body portion may have a generally oval transverse cross-section along its length that has a major axis (A_{major}) and a minor axis (A_{minor}). The major axis may have a dimension of about 3 to about 4 mm. The minor axis may have a dimension of about 1.5 to about 2.5 mm. During compression, a first axis (e.g., the minor axis) width may decrease while a second axis (e.g., the major axis) width may increase.

[0049] As shown in Figs. 5 and 6, the sample portion may have a length (L_S) that is longer than the length (L_H) of the head portion. For example, the sample portion may have a length that is greater than the length of the head portion by a factor of at least about 6. The length of the sample portion may be at least about 20 mm. For example, it may be about 25 to about 35 mm (e.g., about 30 mm).

[0050] As seen, the sample portion has an outer profile that tapers along the longitudinal axis so that it narrows as it approaches the closed end of the tube. As shown in Fig. 2, the sample portion may have an outer profile that tapers generally continually along substantially the entirety of the length of the sample portion. The dimension of the minor axis reduces from its original dimension at the juncture between the head portion and the sample portion to about one third of the original dimension at the juncture as it approaches the closed end of the tube. The ratio of the dimensions of the minor axis to the major axis at juncture location where the head portion adjoins the sample portion may be about 1:2 to about 1:3.5. The minor axis has a dimension of about 1 mm at the distal end. At the region about the distal end, the outer wall of the tube may be tapered to a width of about 1.25 mm.

[0051] Substantially along the length of the sample portion, the tube may have a wall thickness of about 0.05 to about 0.2 mm. The distal end may have a wall thickness that is greater than the wall thickness along the length of the sample portion by an amount of at least about twice. The distal end may have a wall thickness that is greater than the wall thickness along the length of the sample portion by an amount of about 10 times or less. The distal end may have a wall thickness that is substantially the same as the wall thickness along the sample portion.

[0052] As seen in Fig. 2, both the outer wall 34 and the inner wall 36 (which are shown as being generally parallel) of the sample portion may continuously taper at a substantially constant slope. Such taper may occur substantially the entire length of the sample portion. The sample portion continuously tapers at a substantially constant slope over a length of about 25 to about 30 mm (e.g., about 28 mm).

[0053] With reference to Fig. 4B, the sample tube portion is configured so that during a compressive engagement an interior volume per unit length of the sample portion 28 at the region proximate the distal end does not exceed an interior volume per unit length of the sample tube located more proximate to the head portion. The sample tube is also configured so that, during the compressive engagement, any deflection of the sample portion occurs relative to a generally fixed pivot region (e.g., a region located between the distal end and the location where the outer wall of the sample portion contacts a sample block). Any deflection of the sample portion may therefore occur relative to the generally fixed pivot region and the amount of angular deflection is less than about 45° relative to the longitudinal axis. Any deflection of the sample portion may therefore occur relative to the generally fixed pivot region and the amount of angular deflection is less than about 90° relative to the longitudinal axis. Any deflection of the sample portion may therefore occur relative to the generally fixed pivot region and the amount of angular deflection is less than about 15° relative to the longitudinal axis. Further, as can be seen from Fig. 4B, the sample tube is configured so that, during the compressive engagement, direct contact between opposing inner wall portions of the sample portion is avoided. Alternatively, during the compressive engagement, direct contact between opposing inner wall portions of the sample portion may occur.

[0054] Further embodiments of the tubes are shown at Fig. 5-8. As shown in Figs. 5 and 6, the sample portion 28 may have a substantially constant cross section along the longitudinal axis (LA), such that the diameter of the tube D_1 remains constant along the sample portion. Further, the sample portion 28 may include opposing substantially flat walls 42 and opposing substantially curved walls 44. As shown for Example at Fig. 6, the intermediate portion 17 may define a neck having a tapered wall of one or more slopes as evidenced by angles (e.g., α_1 , α_2) relative to the bottom of the intermediate portion where it intersects with the body portion 28. Alternatively, as shown in Figs. 7 and 8, the sample portion 28 may form a substantially cylindrical opening, such that the diameter of the sample portion (D_1) remains constant along the length of the length of the sample

portion. The opening 26 of the head portion 13 may be circular such that the shape of the opening 26 is consistent with the shape of the sample portion 28.

[0055] Additional embodiments of the tube are shown at Figs. 9-18. The dimensions shown in the drawings are incorporated by reference herein as illustrative examples of the teachings. The relative proportions shown in the drawings are likewise incorporated by reference herein even if not expressly recited in this description. For example, the drawings illustrate a ratio of a length of the sample portion the a length of the head portion of approximately 6:1 so that such a ratio is considered to be within the scope of the teachings herein. The ratio of a length of the sample portion the a length of the head portion may be approximately 3:1, 2:1 or 1:1. The teachings are not limited solely to the embodiments and dimensions shown in the drawings.

[0056] The head portion is preferably integrally formed with the sample portion so that both the head portion and sample portion have a smooth surface with the only attachment or projection extending from either the head portion or sample portion being the closure portion. The head portion and sample portion may be integrally formed, but may be formed with a feature located intermediate the head portion and sample portion that acts as a stop to assist in locating the tube in a desired location within an opening during use. The diameter of the tube may expand in moving from the sample portion to the head portion to form the intermediate portion. The sample portion, the head portion, the closure portion or any combination thereof may be formed of a single layer of polymeric material. The closed end of the tube may be circular in shape, ovoid in shape, conical in shape, or substantially rectangular in shape. The tube may be substantially free of a triangular shaped closed end. The interior of the sample portion may form a smooth surface containing no additional elements (e.g., openings, receptacles, vessels, extensions, attachments, ridges) within the sample portion. The exterior of the sample portion may form a smooth surface containing no additional elements (e.g., openings, receptacles, vessels, extensions, attachments, ridges) within the sample portion. The sample portion may also be substantially free of any openings (e.g., ports). The sample portion may include only flexible walls

and may be free of any rigid walls or rigid wall portions. The sample portion may include only rigid walls and may be free of any flexible walls or flexible wall portions.

[0057] When the closure portion is located into the sample portion to seal the tube, the top of the closure portion may be substantially flat with no attachments or extensions located on the closure portion. The closure portion may include a membrane located thereon to allow for access into the tube. Alternatively, the closure portion may be substantially free of any membrane. The closure portion may have an open position and a closed position. The closure portion may also be substantially free of any moving parts. More specifically, the closure portion may be substantially free of any parts to assist the closure portion in securely closing the tube. The strap connecting the closure portion to the head portion is preferably flexible with no means for securing the head portion in an open position or partially open position. The strap portion may also be free of substantial rigidity such that the strap will be unable to support the tube if any attempt is made to rest the tube on the strap or closure portion. More specifically, the tube may be free of any mechanism by which the tube can be supported in an upright position without the assistance of a separate holder. The head portion may include a textured surface. The textured surface may be adapted to receive printed or written information to identify patient information for a sample received within the tube.

[0058] The tube may be a fixed oval shape which may not be deformable. The sample portion may be substantially free of defined edges. The sample portion may receive non-biological. The sample portion may receive identifying information, which may include an RFID code. The head portion may be substantially rigid so that it does not deform.

[0059] As to all of the foregoing general teachings, as used herein, unless otherwise stated, the teachings envision that any member of a genus (list) may be excluded from the genus; and/or any member of a Markush grouping may be excluded from the grouping.

[0060] Unless otherwise stated, any numerical values recited herein include all values from the lower value to the upper value in increments of one unit provided that there is a separation of at least 2 units between any lower value and any higher value. As an example, if it is stated that the amount of a component, a property, or a value of a process variable such as, for example, temperature, pressure, time and the like is, for example, from 1 to 90, preferably from 20 to 80, more preferably from 30 to 70, it is intended that intermediate range values such as (for example, 15 to 85, 22 to 68, 43 to 51, 30 to 32 etc.) are within the teachings of this specification. Likewise, individual intermediate values are also within the present teachings. For values which are less than one, one unit is considered to be 0.0001, 0.001, 0.01 or 0.1 as appropriate. These are only examples of what is specifically intended and all possible combinations of numerical values between the lowest value and the highest value enumerated are to be considered to be expressly stated in this application in a similar manner. As can be seen, the teaching of amounts expressed as "parts by weight" herein also contemplates the same ranges expressed in terms of percent by weight. Thus, an expression in the Detailed Description of the Invention of a range in terms of at "x" parts by weight of the resulting polymeric blend composition" also contemplates a teaching of ranges of same recited amount of "x" in percent by weight of the resulting polymeric blend composition."

[0061] Unless otherwise stated, all ranges include both endpoints and all numbers between the endpoints. The use of "about" or "approximately" in connection with a range applies to both ends of the range. Thus, "about 20 to 30" is intended to cover "about 20 to about 30", inclusive of at least the specified endpoints. Concentrations of ingredients identified in Tables herein may vary $\pm 10\%$, or even 20% or more and remain within the teachings.

[0062] The disclosures of all articles and references, including patent applications and publications, are incorporated by reference for all purposes. The term "consisting essentially of" to describe a combination shall include the elements, ingredients, components or steps identified, and such other elements ingredients, components or steps that do not materially affect the basic and novel

characteristics of the combination. The use of the terms "comprising" or "including" to describe combinations of elements, ingredients, components or steps herein also contemplates embodiments that consist essentially of, or even consist of the elements, ingredients, components or steps. Plural elements, ingredients, components or steps can be provided by a single integrated element, ingredient, component or step. Alternatively, a single integrated element, ingredient, component or step might be divided into separate plural elements, ingredients, components or steps. The disclosure of "a" or "one" to describe an element, ingredient, component or step is not intended to foreclose additional elements, ingredients, components or steps.

[0063] It is understood that the above description is intended to be illustrative and not restrictive. Many embodiments as well as many applications besides the examples provided will be apparent to those of skill in the art upon reading the above description. The scope of the invention should, therefore, be determined not with reference to the above description, but should instead be determined with reference to the appended claims, along with the full scope of equivalents to which such claims are entitled. The disclosures of all articles and references, including patent applications and publications, are incorporated by reference for all purposes. The omission in the following claims of any aspect of subject matter that is disclosed herein is not a disclaimer of such subject matter, nor should it be regarded that the inventors did not consider such subject matter to be part of the disclosed inventive subject matter.

CLAIMS

What is claimed is:

- 1) A polymeric sample tube, comprising:
 - a. a closure portion,
 - b. a strap integrally connected to the closure portion and being configured for defining a living hinge;
 - c. a body portion having a longitudinal axis and an outer wall generally circumscribing the longitudinal axis, and being integrally and hingedly connected with the closure portion by way of the strap, the body portion including a head portion that has an opening through which a sample is dispensed, and a sample portion having a first outer wall dimension and including a closed distal end and a wall structure that includes an outer wall and an inner wall structure that defines a hollow cavity within which the sample resides as a sample volume after is dispensed through the head portion, the closed-ended hollow sample portion being generally elongated along the longitudinal axis and being configured for elastic deformation along a portion of its length, including in a direction that is generally transverse to the longitudinal axis so that at least a portion of the wall structure compressively and resiliently deforms and engages a wall defining an opening in a sample block of a polymerase chain reaction amplification device, and the first outer wall dimension of the sample portion reduces to a smaller second outer wall dimension.
- 2) The sample tube of claim 1, wherein the closure portion includes a tab portion, and an adjoining plug portion.
- 3) The sample tube of claim 1 or 2, wherein the head portion is dimensioned for frictionally engaging the closure portion.

- 4) The sample tube of claim 1 or 2, wherein the head portion is dimensioned for frictionally engaging the closure portion and engaging the closure portion by way of a snap-fit.
- 5) The sample tube of any of claims 1 through 4, wherein the head portion is generally cylindrical.
- 6) The sample tube of any of claims 1 through 5, wherein the sample portion has a length that is greater than the length of the head portion by a factor of at least about 6.
- 7) The sample tube of any of claims 1 through 6, wherein the sample portion, along substantially the entirety of its length, has a transverse cross-section outer profile that includes a transverse minor axis and a transverse major axis.
- 8) The sample tube of any of claims 1 through 7, wherein the closed-ended hollow sample portion has an outer profile that tapers along the longitudinal axis so that it narrows as it approaches the closed end of the tube.
- 9) The sample tube of any of claims 1 through 8, wherein the sample portion has an outer profile that tapers generally continually along substantially the entirety of the length of the sample portion so that it narrows in at least one axis transverse to the longitudinal axis from a first outer wall dimension to a second outer wall dimension that is less than about one half (e.g., about one third) of the first outer wall dimension as it approaches the closed end of the tube.

- 10) The sample tube of any of claims 1 through 9, wherein the sample portion is defined by an interior wall that has a generally oval cross section in a direction transverse to the longitudinal axis, for substantially the entirety of the length of the closed-ended hollow sample portion.
- 11) The sample tube of any of claims 1 through 10, wherein the sample portion is defined by an interior wall that has a generally oval cross section that includes a minor axis and a major axis that is generally perpendicular to the minor axis, with each axes being oriented in a direction transverse to the longitudinal axis and having a dimension, for substantially the entirety of the length of the closed-ended hollow sample portion.
- 12) The sample tube of claim 11, wherein the ratio of the dimensions of the minor axis to the major axis at a location where the head portion adjoins the sample portion is about 1:2 to about 1:3.5.
- 13) The sample tube of claim 11, wherein the minor axis has a dimension of about 1 mm at the distal end.
- 14) The sample tube of any of claims 1 through 13, wherein substantially along the length of the sample portion, the tube has a wall thickness of about 0.05 to about 0.2 mm.
- 15) The sample tube of any of claims 1 through 14, wherein substantially along the length of the sample portion, the tube has a wall thickness of about 0.05 to about 0.2 mm, and the distal end has a wall thickness that is greater than the wall thickness along the length of the sample portion by an amount of at least about twice and about ten times or less.
- 16) The sample tube of any of claims 1 through 15, wherein at about the distal end, the tube is tapered to a width of about 1.25 mm.

- 17) The sample tube of any of claims 1 through 16, wherein the head portion has a generally circular transverse cross-section along its length that has an inner diameter of about 3 to about 4 mm.
- 18) The sample tube of any of claims 1 through 16, wherein the head portion has a generally oval outer transverse cross-section and generally round inner transverse cross section along its length that has an inner diameter of about 3 to about 4 mm.
- 19) The sample tube of any of claims 1 through 18, wherein the outer wall of the sample portion continuously tapers at a substantially constant slope.
- 20) The sample tube of claim 19, wherein the sample portion continuously tapers at a substantially constant slope over a length of about 25 to about 30 mm (e.g., about 28 mm).
- 21) The sample tube of any of claims 1 through 20, wherein the sample portion includes an optically transparent portion so that a reaction taking place within the sample portion can be monitored optically through the closed end, or a side or a lid.
- 22) The sample tube of any of claims 1 through 21, wherein the sample tube is made of polypropylene.
- 23) The sample tube of any of claims 1 through 22, wherein the sample tube is made of a polypropylene that is sufficiently optically transparent, so that a reaction taking place within the sample portion can be monitored optically.

- 24) The sample tube of any of claims 1 through 23, wherein the distal end is sufficiently optically transparent, so that a reaction taking place within the sample portion can be monitored optically.
- 25) The sample tube of any of claims 1 through 24, wherein the entire tube is a unitary molded body that is free of any fusion joint.
- 26) The sample tube of any of claims 1 through 24, wherein the entire tube is a unitary body that includes the head portion and the sample portion that include a fusion joint between them.
- 27) The sample tube of any of claims 1 through 26, wherein the sample tube portion is configured so that during the compressive engagement an interior volume per unit length of the sample tube portion at the region proximate the distal end does not exceed an interior volume per unit length of the sample tube located more proximate to the head portion.
- 28) The sample tube of any of claims 1 through 27, wherein the sample tube portion is configured so that during the compressive engagement, any deflection of the sample portion occurs relative to a generally fixed pivot region.
- 29) The sample tube of any of claims 1 through 28, wherein the sample tube portion is configured so that during the compressive engagement, any deflection of the sample portion occurs relative to a generally fixed pivot region and the amount of angular deflection is less than about 45° relative to the longitudinal axis.
- 30) The sample tube of any of claims 1 through 29, wherein the sample tube portion is configured so that during the compressive engagement, direct

contact between opposing inner wall portions of the sample portion is avoided.

- 31) The sample tube of any of claims 1 through 30, wherein the head portion is formed so that sufficient space exists to collect air pressure created when the tube is compressed.
- 32) The tube of any of claims 1 through 30, wherein the tube opening is formed for pipette loading.
- 33) A method of making the tube of any of claims 1 through 25 and 27 through 32, comprising injection molding a polymeric material into a mold.
- 34) A method of making the tube of any of claims 1 through 24 and 26 through 32, comprising fusing two or more pre-formed portions of the tube together to define the tube.
- 35) A method of making the tube of any of claims 1 through 24 and 26 through 32, wherein the method includes steps of extruding the sample portion and then fusing the extruded sample portion with the head portion.
- 36) Use of a tube of any of claims 1 through 32 to receive a sample for nucleic acid amplification.
- 37) Use of a tube of any of claims 1 through 32 to amplify a sample for nucleic acid amplification in a thermocycler.
- 38) Use of a tube of any of claims 1 through 32 to amplify a sample for nucleic acid amplification in a thermocycler that has a sample block (optionally a solid metal sample block, such as a silver sample block) that includes at

least one bore defined by a wall having a generally oval transverse section along at least a portion of its length.

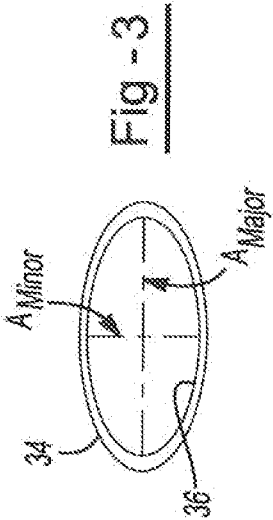

Fig - 3

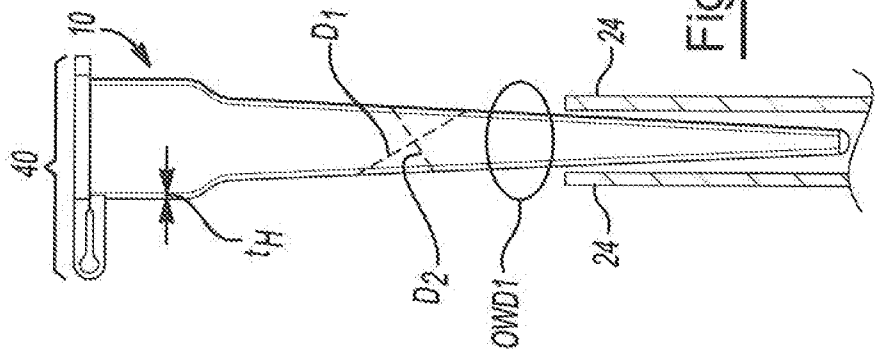

Fig - 4A

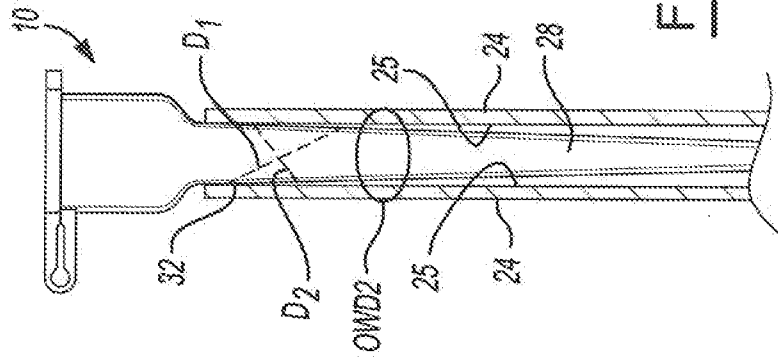

Fig - 4B

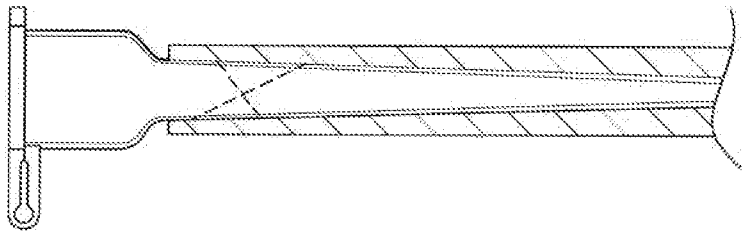
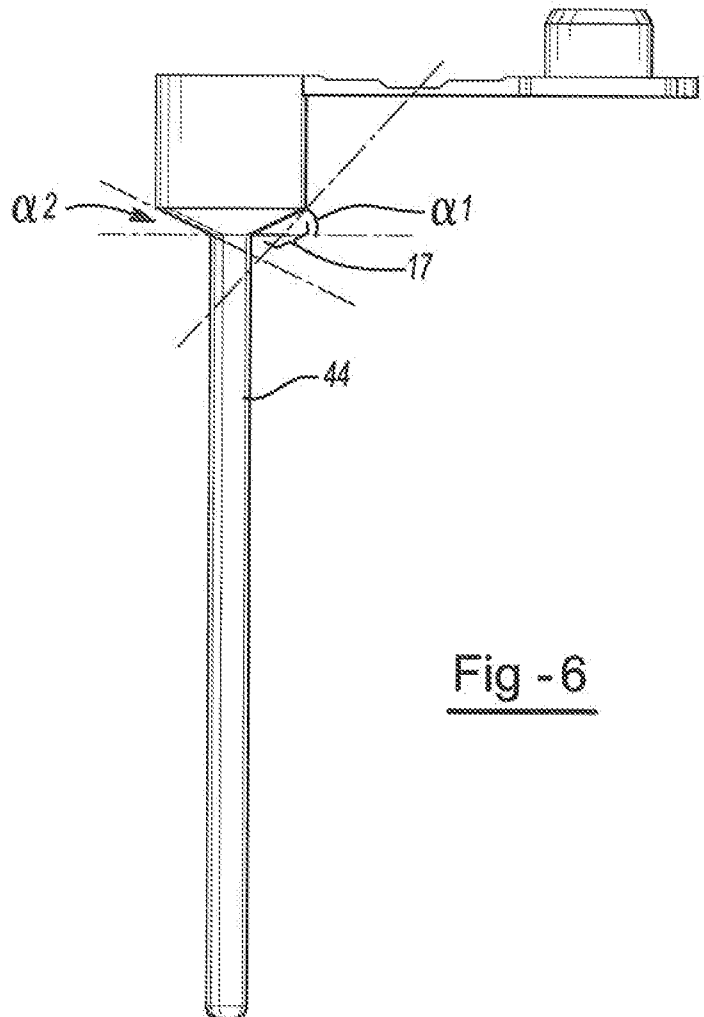
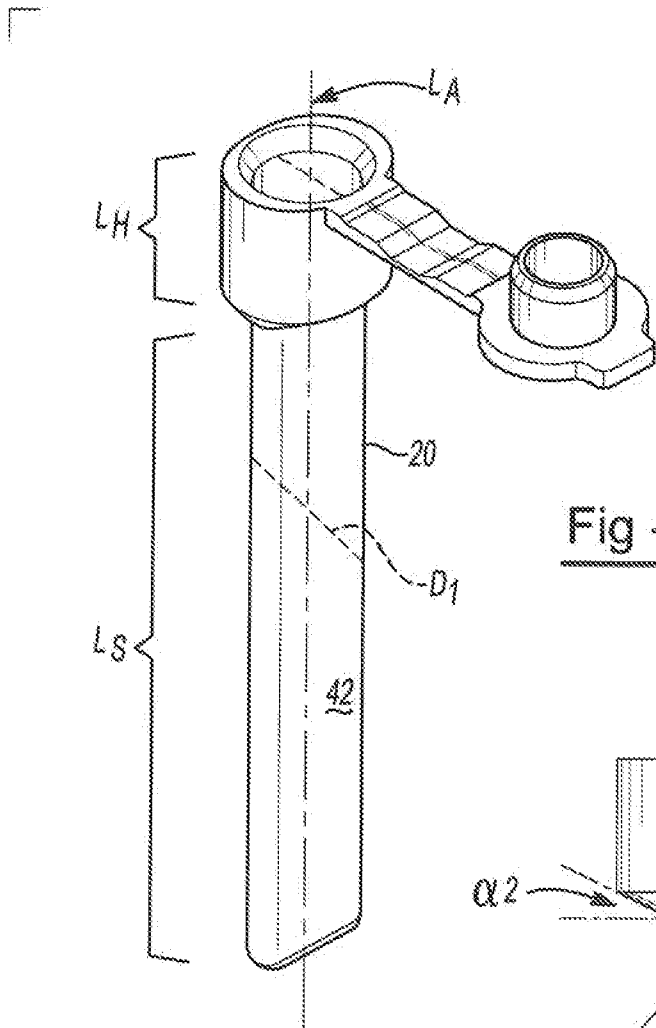

Fig - 4C





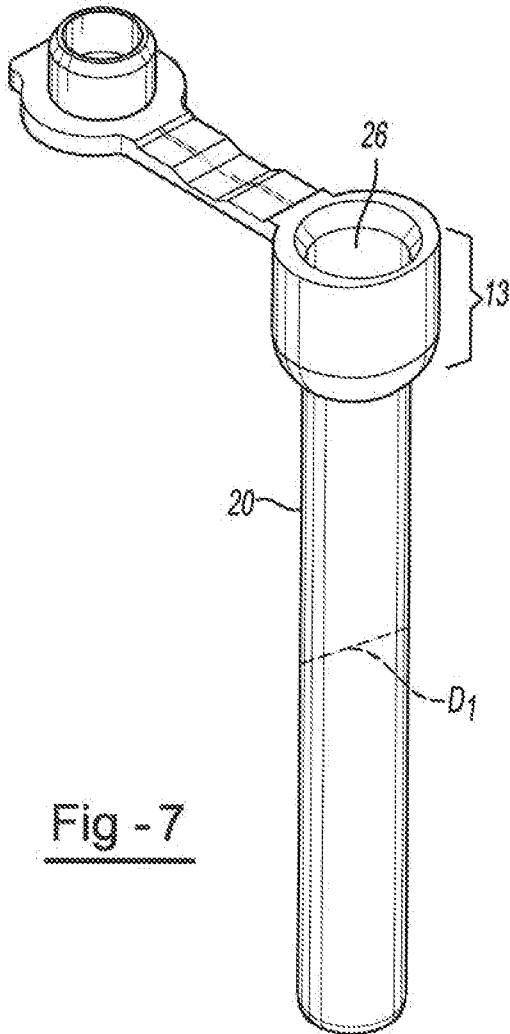

Fig - 7

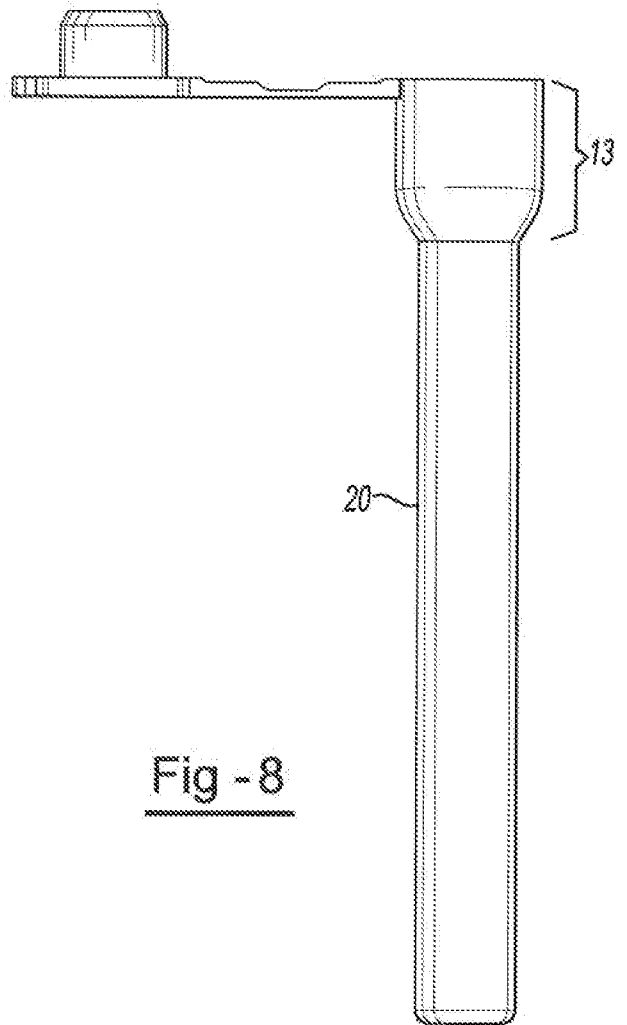

Fig - 8



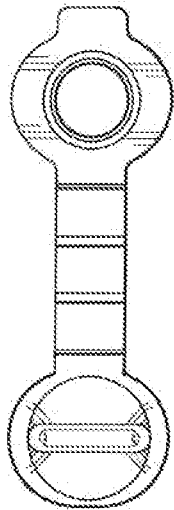

Fig - 9

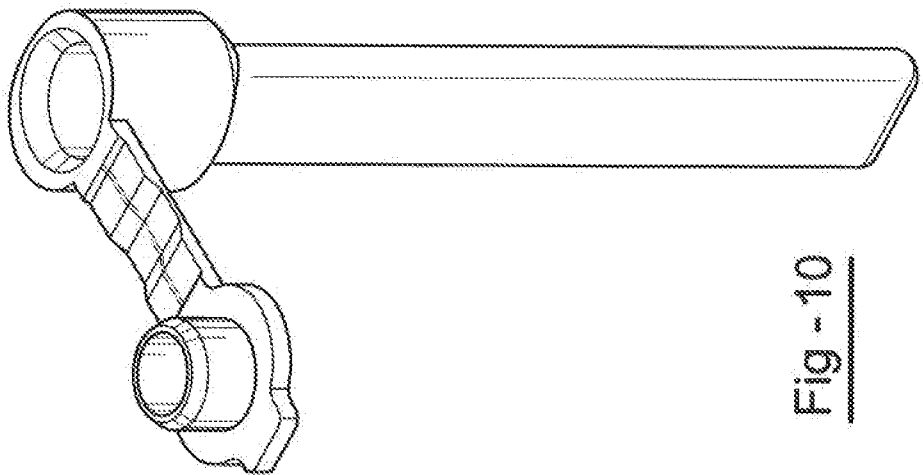

Fig - 10

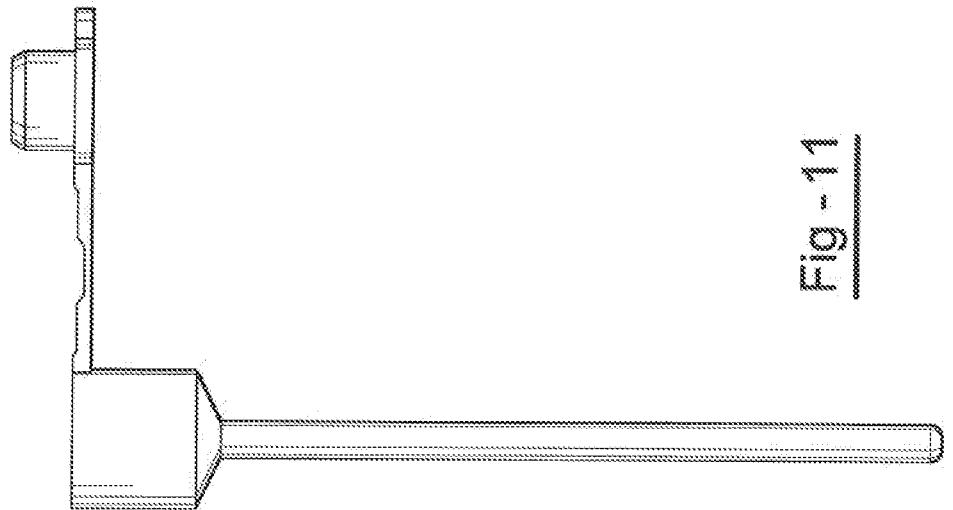

Fig - 11

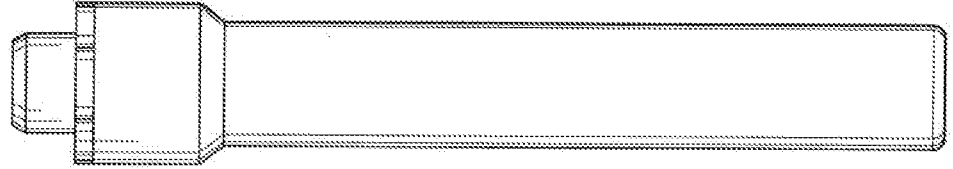

Fig - 12



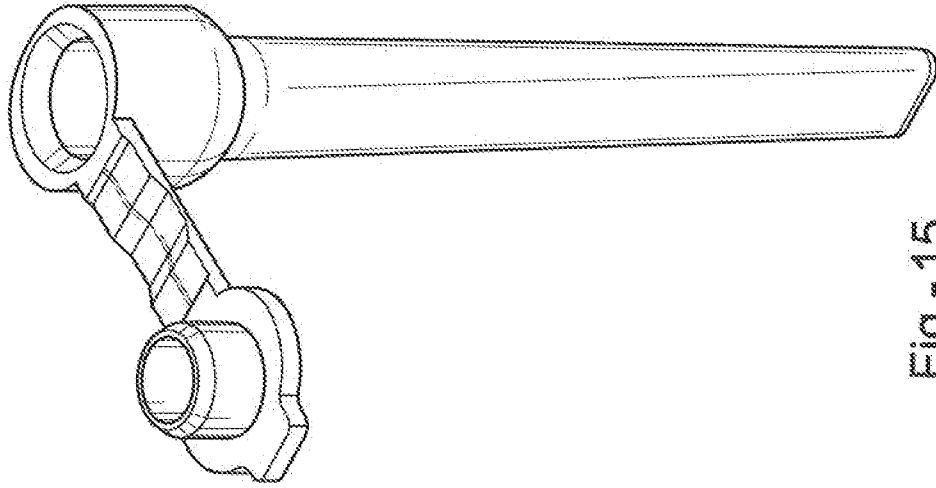

Fig - 15

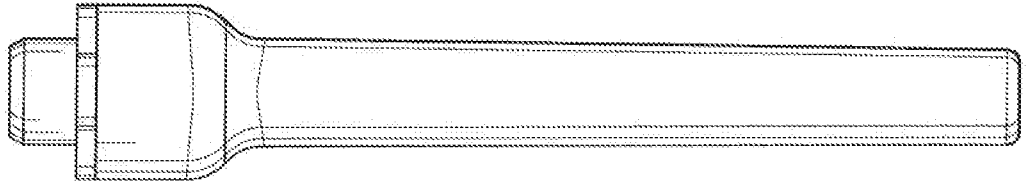

Fig - 14

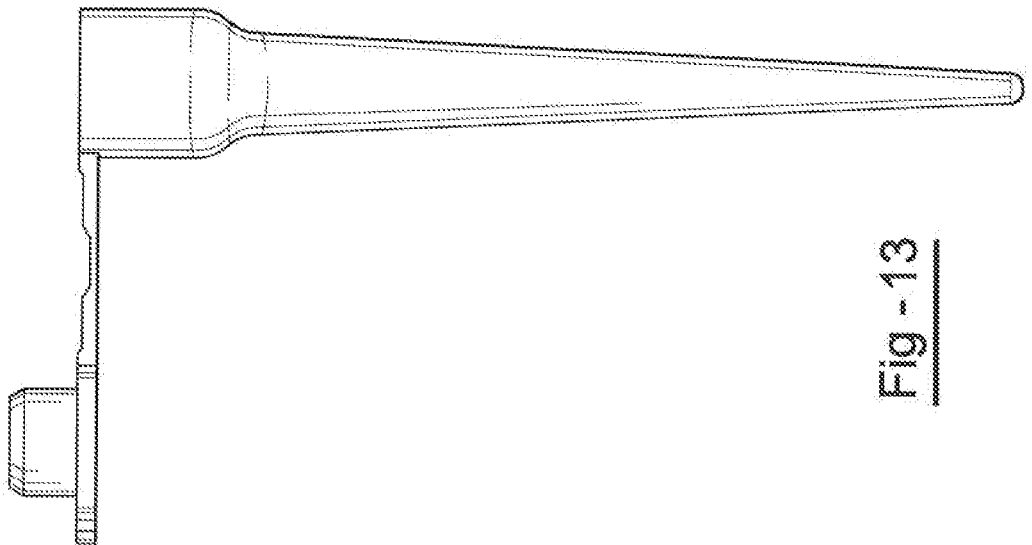

Fig - 13



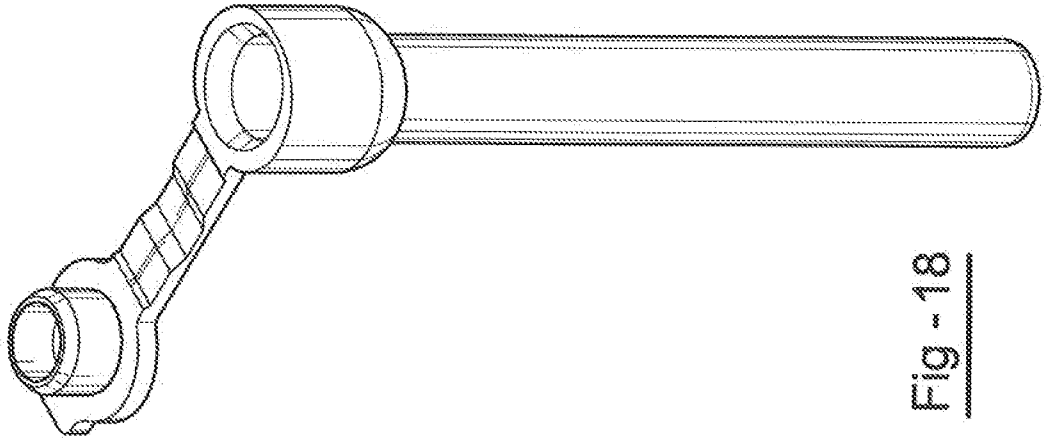

Fig - 18

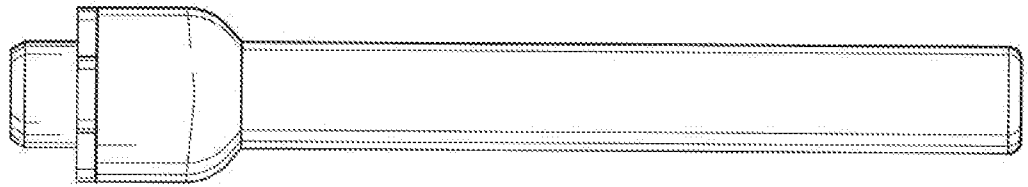

Fig - 17

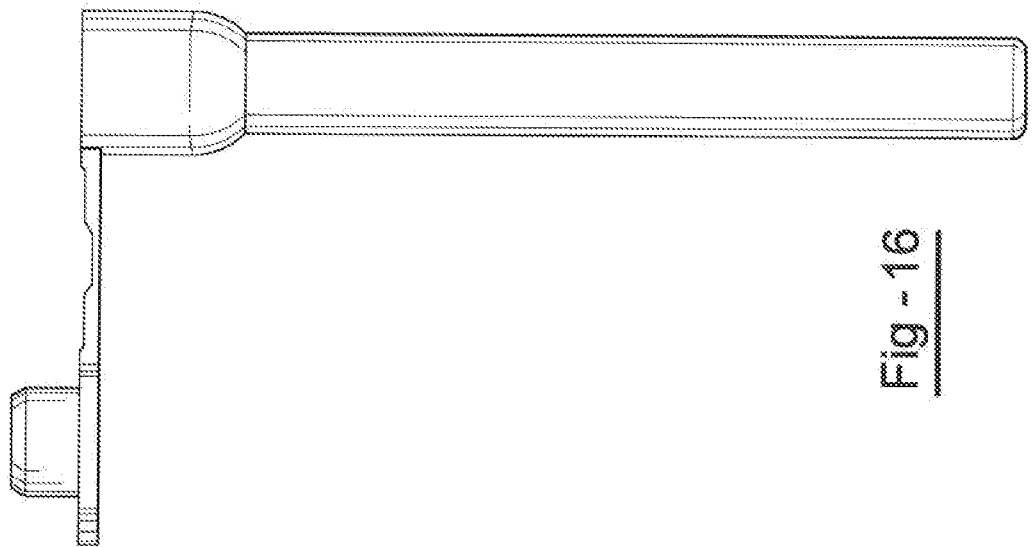

Fig - 16

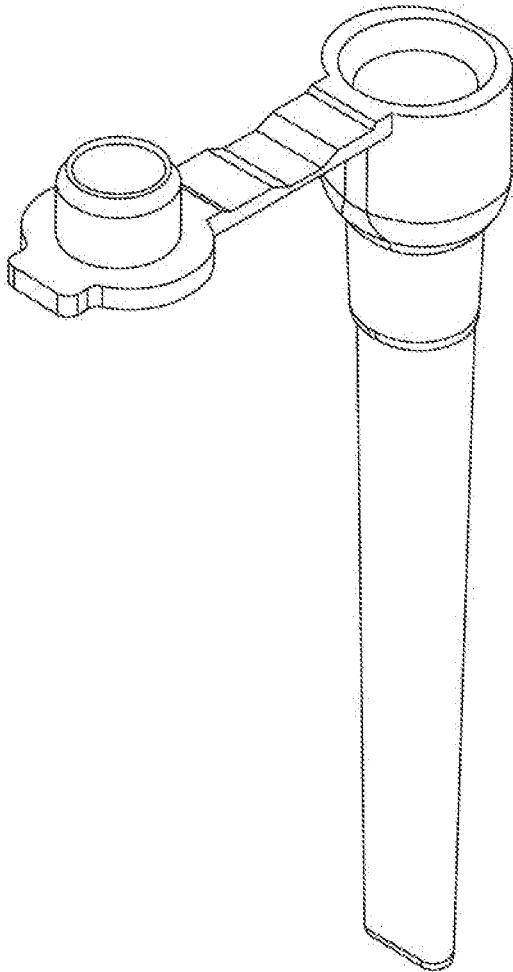

Fig - 19

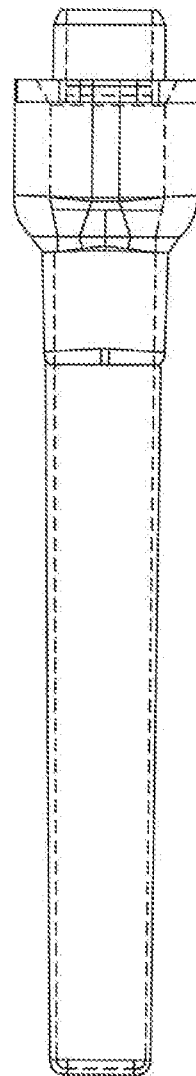

Fig - 20



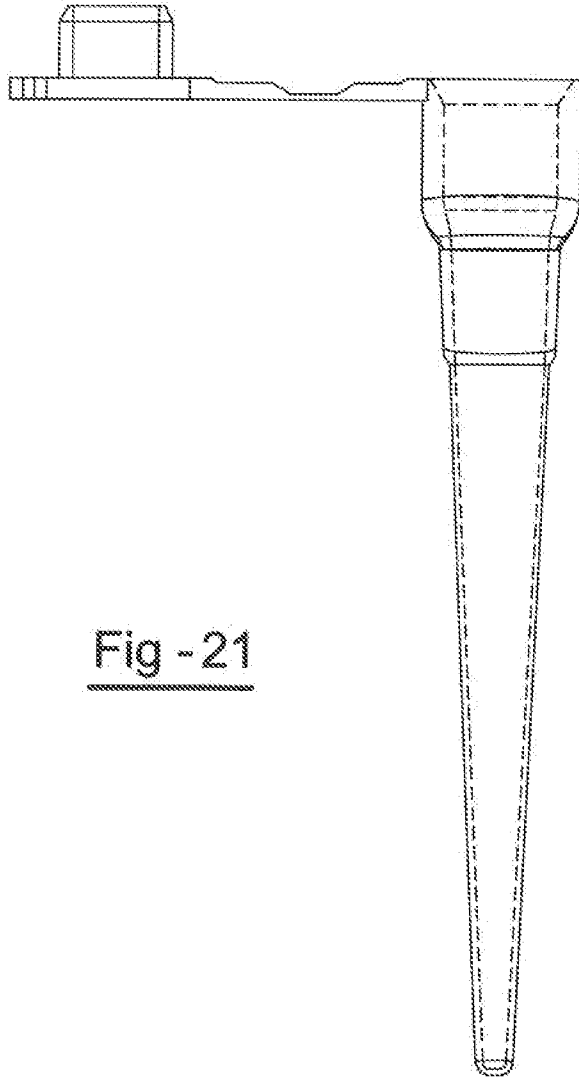

Fig - 21

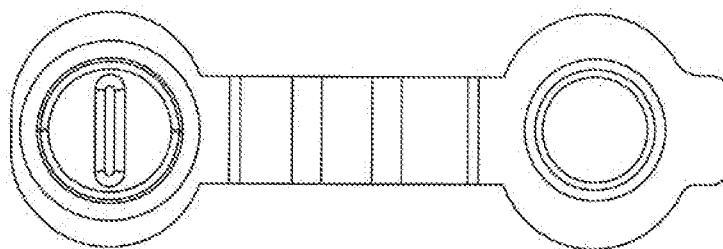

Fig - 22



INTERNATIONAL SEARCH REPORT

International application No
PCT/US2012/034506

A. CLASSIFICATION OF SUBJECT MATTER
INV. B01L3/00
ADD.

According to International Patent Classification (IPC) or to both national classification and IPC

B. FIELDS SEARCHED
Minimum documentation searched (classification system followed by classification symbols)
B01L

Documentation searched other than minimum documentation to the extent that such documents are included in the fields searched

Electronic data base consulted during the international search (name of data base and, where practicable, search terms used)
EPO-Internal, WPI Data

C. DOCUMENTS CONSIDERED TO BE RELEVANT

Category*	Citation of document, with indication, where appropriate, of the relevant passages	Relevant to claim No.
X	US 5 225 165 A (PERLMAN DANIEL [US]) 6 July 1993 (1993-07-06)	1-9,17, 19,22, 27-33,36
Y	column 1, line 9 - column 1, line 38; figures 1-5 column 4, line 67 - column 5, line 5 column 5, line 67 - column 6, line 14 -----	26,34,35
X	WO 2006/024879 A1 (EVOGEN LTD [GB]; COBB BEN [GB]) 9 March 2006 (2006-03-09) page 1, line 7 - line 9; figures 1-4 page 3, line 8 - page 4, line 19 page 4, line 30 - page 5, line 17 page 6, line 20 - page 8, line 11 ----- -/--	1-9, 14-17, 19-25, 27-33, 36-38

Further documents are listed in the continuation of Box C. See patent family annex.

* Special categories of cited documents :

"A" document defining the general state of the art which is not considered to be of particular relevance	"T" later document published after the international filing date or priority date and not in conflict with the application but cited to understand the principle or theory underlying the invention
"E" earlier application or patent but published on or after the international filing date	"X" document of particular relevance; the claimed invention cannot be considered novel or cannot be considered to involve an inventive step when the document is taken alone
"L" document which may throw doubts on priority claim(s) or which is cited to establish the publication date of another citation or other special reason (as specified)	"Y" document of particular relevance; the claimed invention cannot be considered to involve an inventive step when the document is combined with one or more other such documents, such combination being obvious to a person skilled in the art
"O" document referring to an oral disclosure, use, exhibition or other means	"&" document member of the same patent family
"P" document published prior to the international filing date but later than the priority date claimed	

Date of the actual completion of the international search 3 August 2012	Date of mailing of the international search report 16/08/2012
--	--

Name and mailing address of the ISA/ European Patent Office, P.B. 5818 Patentlaan 2 NL - 2280 HV Rijswijk Tel. (+31-70) 340-2040, Fax: (+31-70) 340-3016	Authorized officer Pessenda García, P
--	--

INTERNATIONAL SEARCH REPORT

International application No
PCT/US2012/034506

C(Continuation). DOCUMENTS CONSIDERED TO BE RELEVANT

Category*	Citation of document, with indication, where appropriate, of the relevant passages	Relevant to claim No.
X	US 2002/086417 A1 (CHEN SHUQI [US]) 4 July 2002 (2002-07-04) paragraphs [0049], [0068] - [0072], [0080] - [0088], [0091] - [0097], [0117], [0118]; figures 1-13g,18-19a -----	1-5, 7-15, 17-21, 24,27-32
Y	EP 2 193 845 A1 (ROCHE DIAGNOSTICS GMBH [DE]; HOFFMANN LA ROCHE [CH]) 9 June 2010 (2010-06-09) paragraphs [0001], [0012], [0090]; claims 1-10,12-14 -----	26,34,35

INTERNATIONAL SEARCH REPORT

Information on patent family members

International application No

PCT/US2012/034506

Patent document cited in search report	Publication date	Patent family member(s)	Publication date		
US 5225165	A	06-07-1993	DE 4315726 A1	18-11-1993	
			GB 2266883 A	17-11-1993	
			JP 6206007 A	26-07-1994	
			US 5225165 A	06-07-1993	
			US 5382408 A	17-01-1995	

WO 2006024879	A1	09-03-2006	EP 1838444 A1	03-10-2007	
			US 2008268506 A1	30-10-2008	
			WO 2006024879 A1	09-03-2006	

US 2002086417	A1	04-07-2002	AT 527061 T	15-10-2011	
			AU 2002246765 A1	30-07-2002	
			CA 2433347 A1	25-07-2002	
			CN 1406154 A	26-03-2003	
			EP 1347833 A2	01-10-2003	
			JP 4205947 B2	07-01-2009	
			JP 2004518129 A	17-06-2004	
			US 2002086417 A1	04-07-2002	
			US 2005019875 A1	27-01-2005	
			US 2006154341 A1	13-07-2006	
			US 2011207121 A1	25-08-2011	
			WO 02057798 A2	25-07-2002	

			EP 2193845	A1	09-06-2010
CN 101735944 A	16-06-2010				
EP 2193845 A1	09-06-2010				
JP 2010148495 A	08-07-2010				
US 2010124779 A1	20-05-2010				
