

- (21) Application No 8324008
- (22) Date of filing 7 Sep 1983
- (30) Priority data
- (31) 8205122
- (32) 9 Sep 1982
- (33) Sweden (SE)
- (43) Application published 23 May 1984
- (51) INT CL<sup>3</sup> B30B 9/32
- (52) Domestic classification B3V 9
- (56) Documents cited None
- (58) Field of search B3V
- (71) Applicant Broderna Holmbergs Fabriks AB, (Sweden), P O Box 63, S-334 00 Anderstorp, Sweden.
- (72) Inventors Ben Elwing, Peter Foldi, Gote Holmberg.
- (74) Agent and/or Address for Service Withers & Rogers, 4 Dyers Buildings, Holborn, London EC1N 2JT.

(54) **Crushing cans**

(57) Machine for crushing cylindrical aluminium cans 23 for beer, soft drinks etc. comprises a can intake 12. A cradle 22 for receiving the can is displaceable between a receiving position in the can intake and a crushing position in a press device (24,25, Figure 5) for squeezing

the cans axially. Displacement of the cradle between the positions is effected by displacement of a closure member 15 for the can intake between opened and closed positions. A perforated sloping plane 26 is arranged below the press device for receiving the crushed can falling down from the press device during return movement thereof after crushing, and diverting the crushed can to a collecting container. A material sensor 32 is adjacent the cradle and the machine is controlled by a computer.

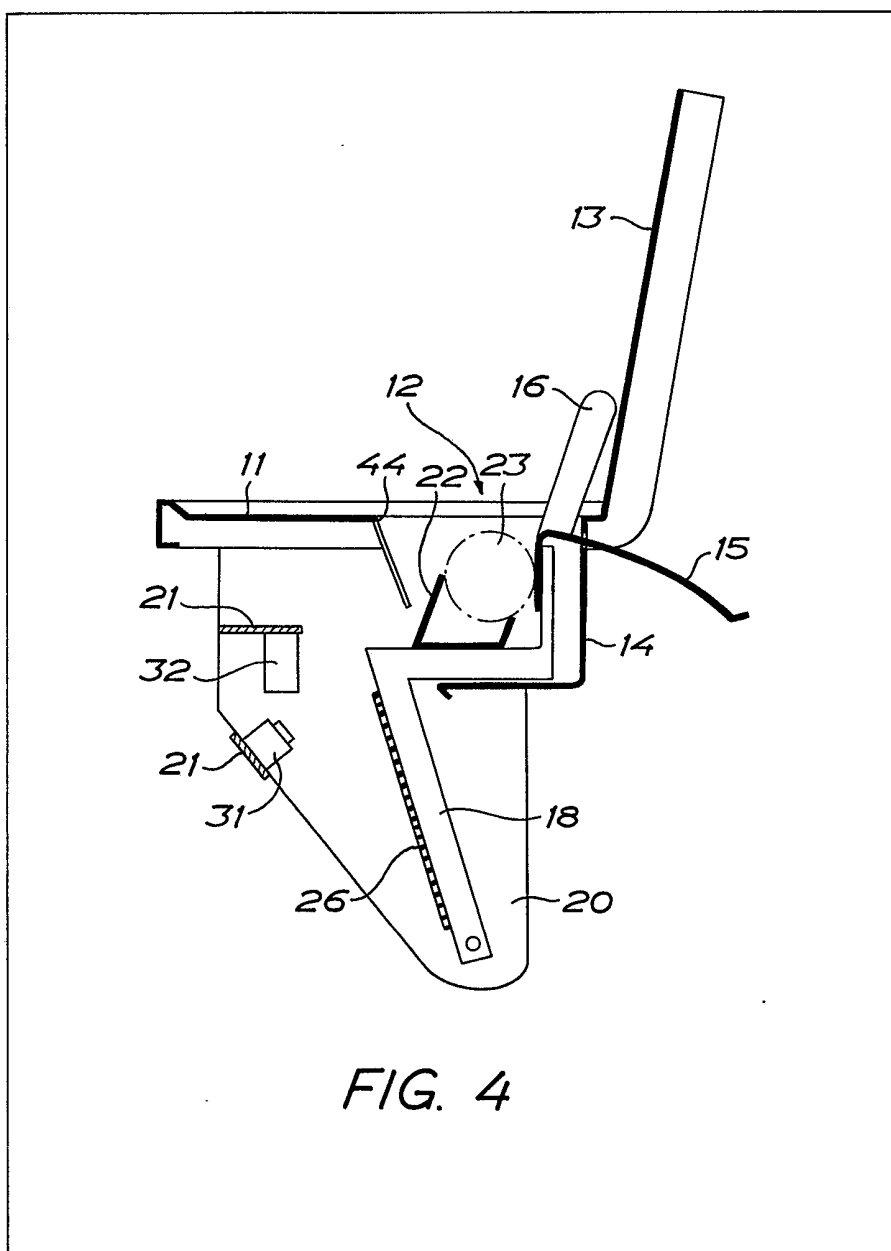

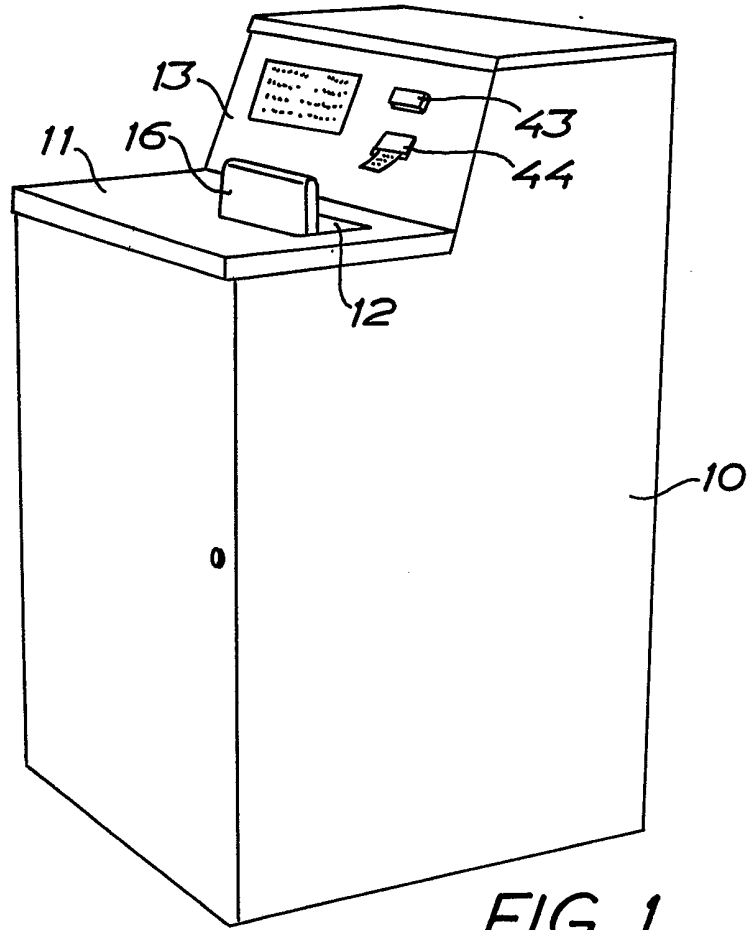

FIG. 1

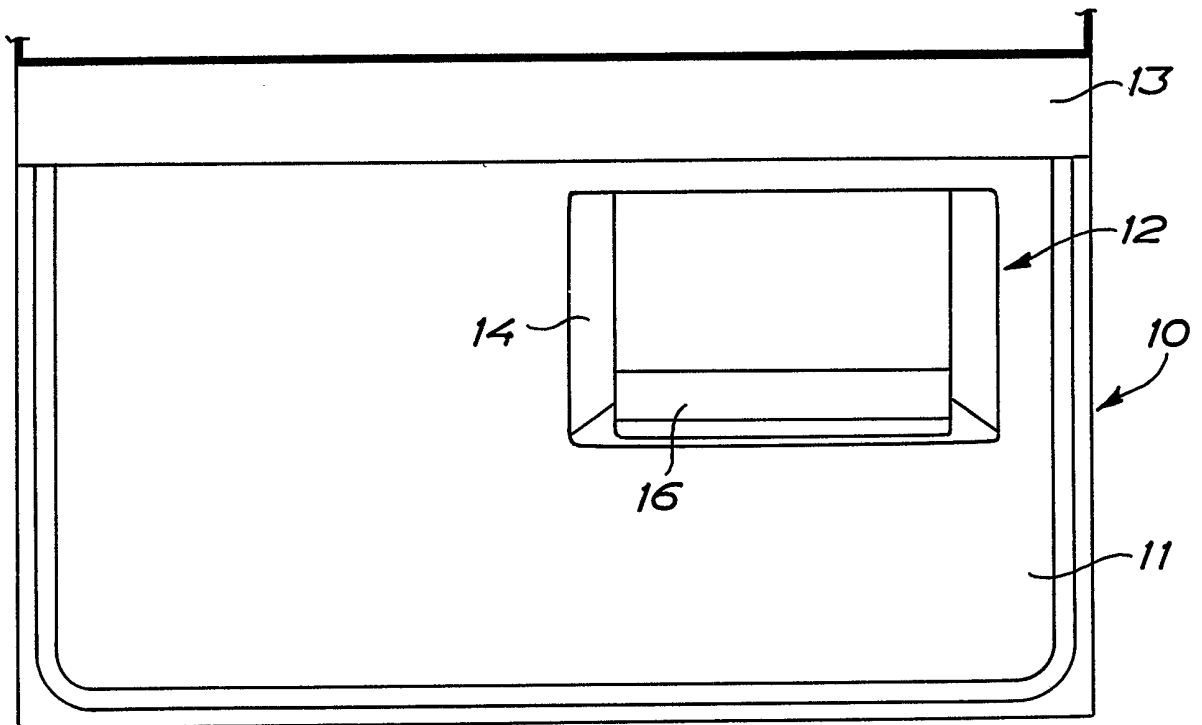

FIG. 2

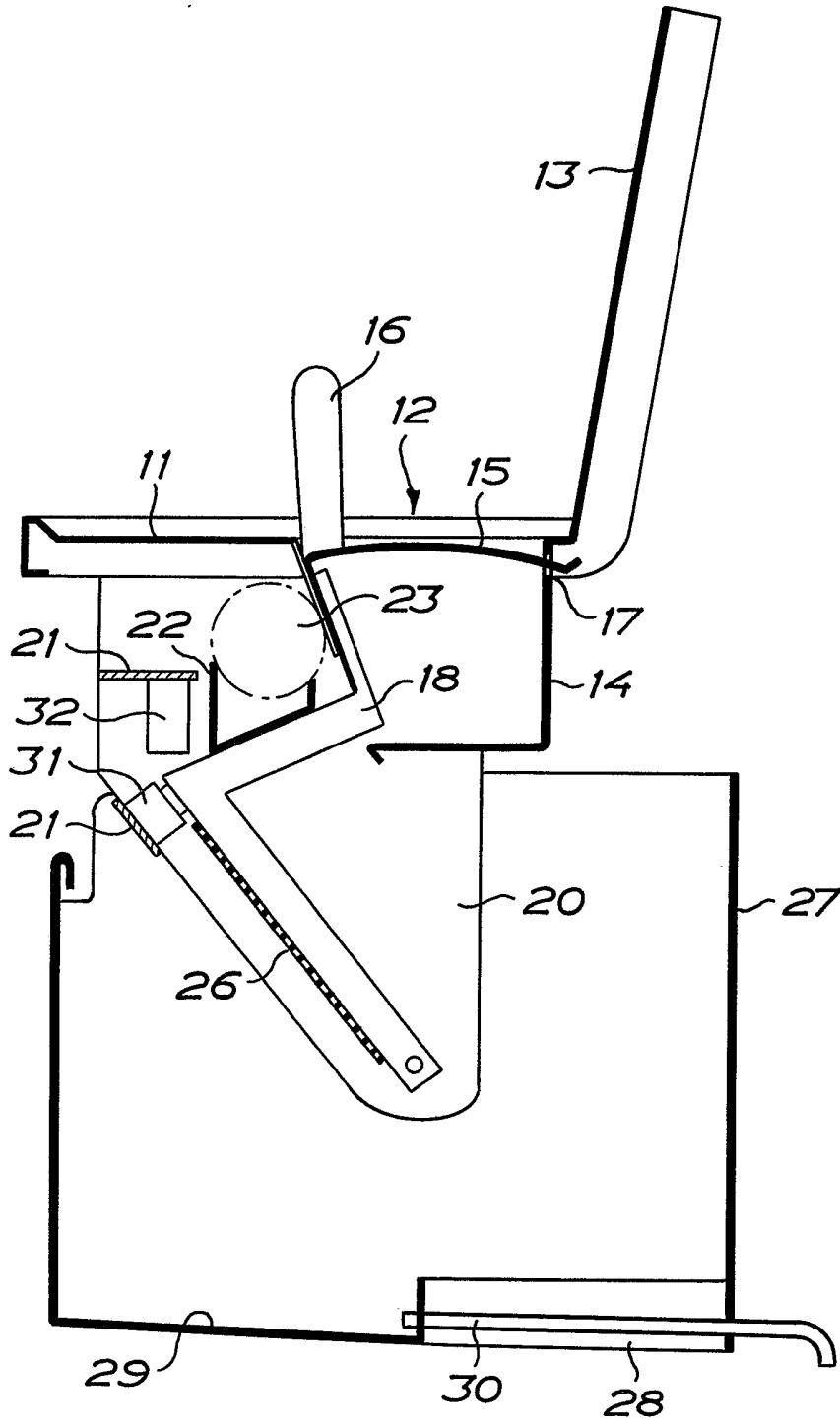

FIG. 3

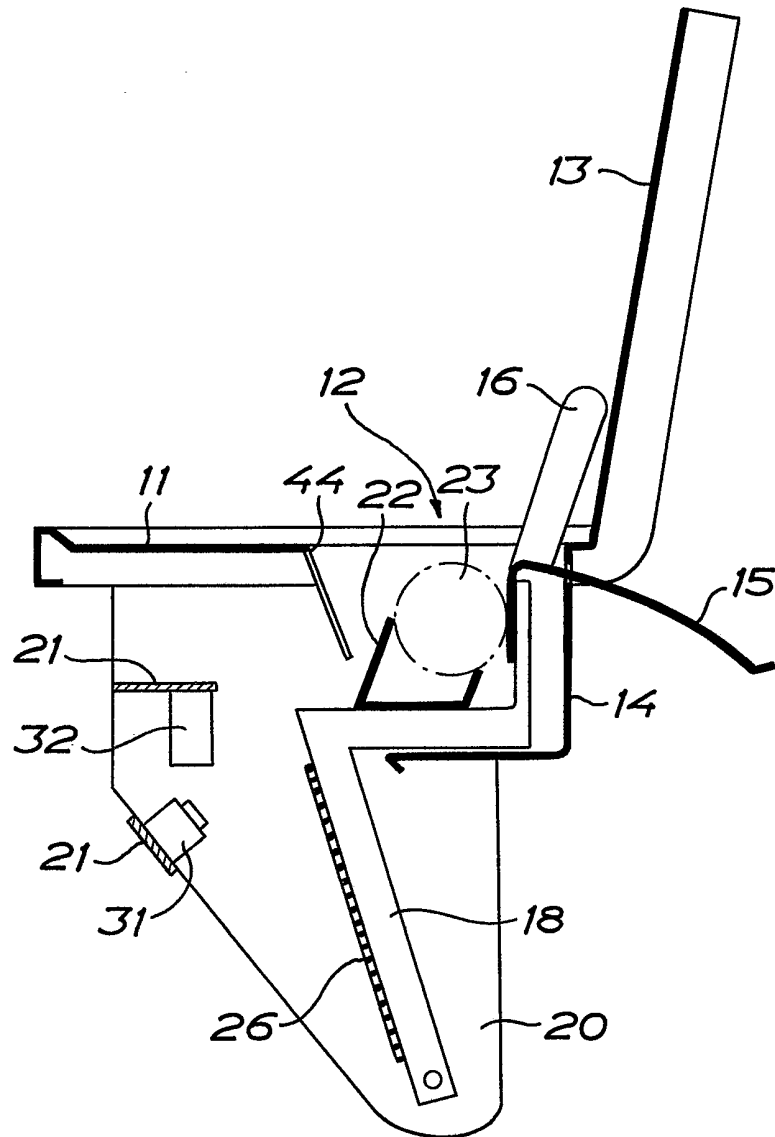

FIG. 4

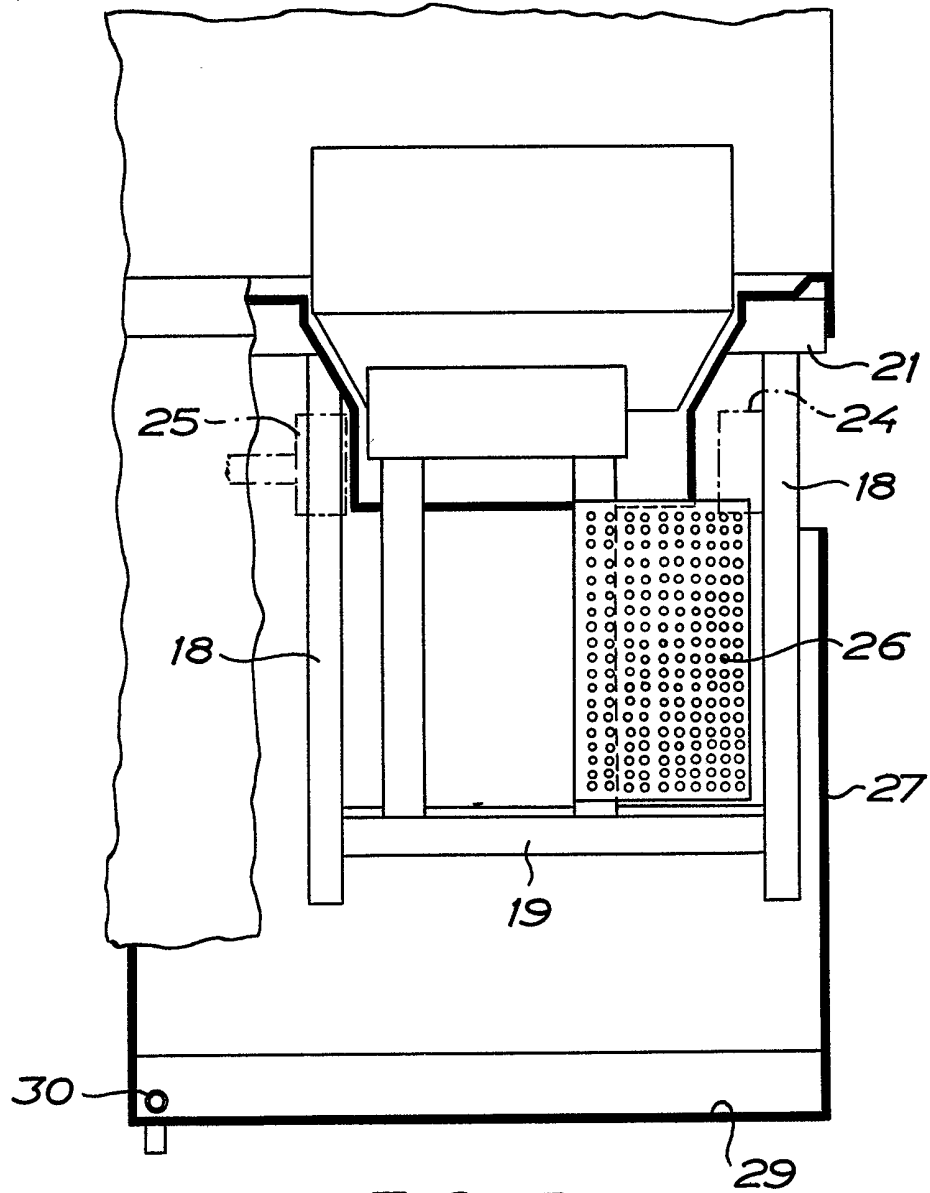

FIG. 5

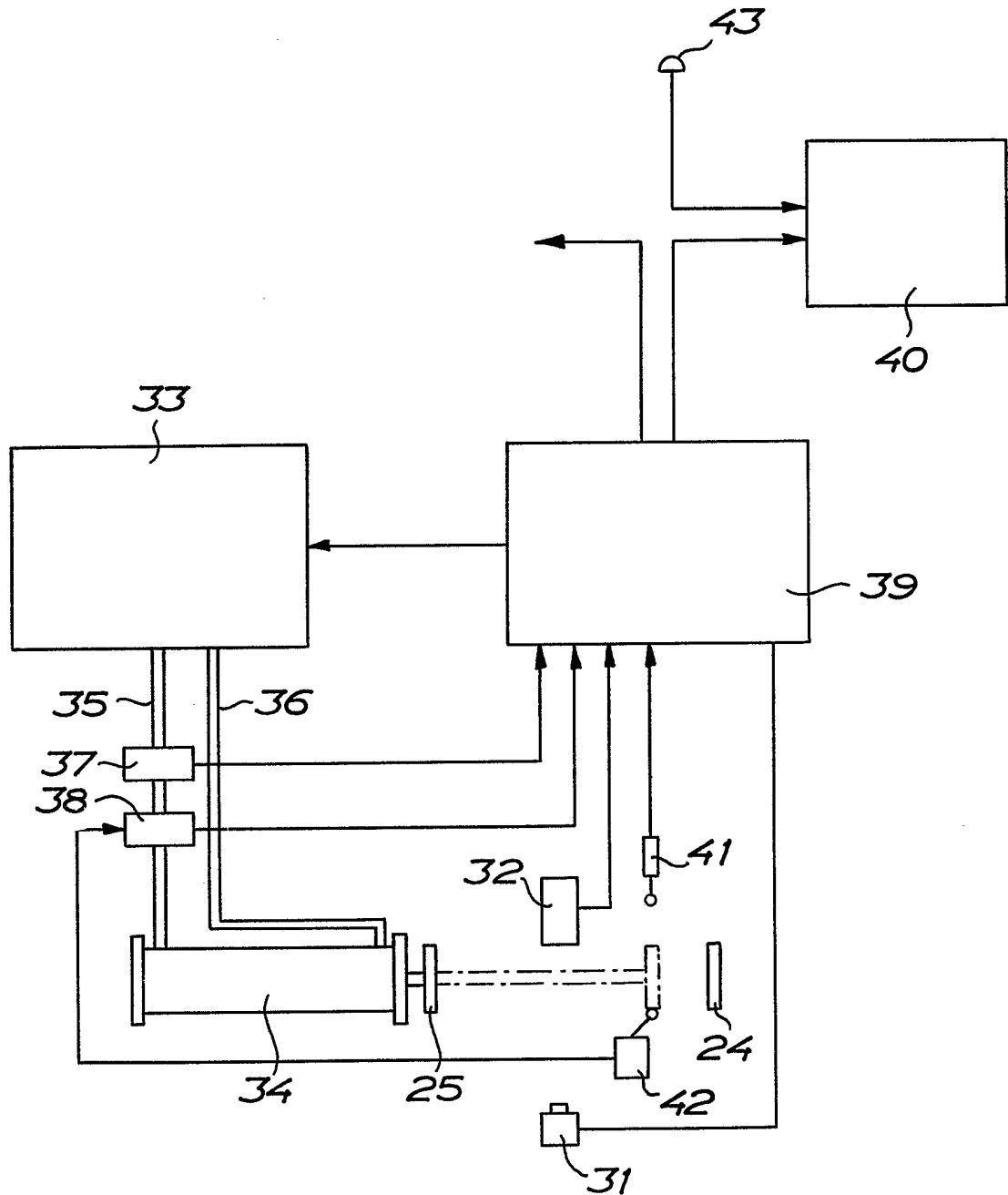

FIG. 6

## SPECIFICATION

**Machine for crushing cans**

5 The present invention relates to a machine for crushing cylindrical aluminium cans for beer, soft drinks etc.

The use of aluminium cans for the distribution of beer and soft drinks has increased the need to  
10 recover empty cans for reuse of the aluminium. In order to accomplish recovery of the cans at reasonable costs it is necessary to crush the bulky cans to a compact shape, and for this purpose machines comprising a can intake and a press device for  
15 squeezing the cans axially between the end walls thereof, have been developed.

The invention aims to facilitate the recovery of aluminium cans by providing a can crushing machine which is suitable for use by the public  
20 without detailed instructions for the operation of the machine, and which in a rational and safe manner receives the cans and crushes them while at the same time disposing of any liquid remaining in the can - this is an average 10% of the original contents.  
25 It is also intended to make possible automatic operation of the machine and to provide security to ensure that only substantially empty aluminium cans are processed in the machine.

According to this invention we propose a machine  
30 for crushing preferably, cylindrical aluminium cans such as used for beer, soft drinks etc., comprising a can intake and a press device for squeezing the cans axially between the end walls thereof, wherein a  
35 cradle for receiving the can in a substantially horizontal position is displaceable between a receiving position in the can intake and a crushing position in the press device by displacement of a closure member for the can intake between opened and  
40 closed positions, and wherein a perforated sloping plane is arranged below the press device for receiving the crushed can falling from the press device at the return thereof after crushing and for diverting the  
crushed can to a collecting container.

Other features of the invention are set forth in the  
45 appendent claims.

Embodiments of the invention will now be described by way of example with reference to the accompanying drawings in which:

- 50 *Figure 1* is a perspective view of the machine;  
*Figure 2* is a plan view of the machine table with a can intake arranged therein;  
*Figure 3* is a partial vertical cross sectional view of the machine through the can intake with a cradle for receiving the can in position for crushing;  
55 *Figure 4* is a view similar to that of *Figure 3* with the cradle in a receiving position;  
*Figure 5* is a partial vertical cross-sectional perpendicular to the view of *Figures 3* and *4* with the cradle in the receiving position; and  
60 *Figure 6* is a block diagram of the hydraulic and electrical systems of the machine.

Referring to *Figures 1* and *2*, the machine has a sheet metal cabinet 10 with a table top 11 in which a can intake 12 is formed, and an operating and  
65 instruction panel 13 which projects from the table

slightly inclining toward the rear thereof. The cabinet 10 is mounted on a frame and encloses hydraulic and electrical operating systems and a suitable receptacle for collecting crushed aluminium cans and has doors providing access to the interior for maintenance and repair work. The device for receiving aluminium cans delivered through the can intake 12 (shown in more details in *Figures 3* to *5*)  
70 comprises a receiving hopper 14 which can be closed at the top thereof by means of a sliding cover 15 having a handle 16 projecting from the table top 11. The sliding cover 15 can be displaced between opened and closed positions through a slot 17 in the receiving hopper 14 and is mounted at one end of two arms 18 the other ends of said arms being interconnected by means of a cross bar 19. At the cross bar the arms are mounted for pivotal movement about a horizontal axis in heavy bearing flanges 20 supported by the frame of the machine,  
75 which is fragmentarily indicated at 21, *Figure 5*. The arms 18 are substantially Z-shaped and on the web extending between the end portions thereof a cradle 22 is mounted for receiving an aluminium can in a horizontal position. In *Figures 3* and *4* a can is indicated by dot-and-dash lines at 23. Preferably, the arms 18 are normally held in the position shown in *Figure 3* either by gravity or by means of a spring, and in this position the can intake 12 is locked by the sliding cover 15 closing the receiving hopper 14. To  
80 insert a can, the sliding cover 15 is slid backwards to the position shown in *Figure 4* at the handle 16 such that the receiving hopper is opened and a can 23 can be laid in the cradle 22. Thus, *Figure 4* shows the cradle in the receiving position thereof. The sliding cover 15 is then closed, the arms 18 being swung counter-clockwise from the position shown in *Figure 3*, which is the crushing position. In the crushing position shown in *Figure 3*, the can 23 received by the cradle 22, is located between a stationary press  
85 jaw 24 indicated by dot-and-dash lines in *Figure 5*, and a movable press jaw also indicated by dot-and-dash lines at 25 in *Figure 5*, which is connected to a hydraulic cylinder. When the hydraulic cylinder is pressurised the can is squeezed axially between the end walls thereof to form a compacted body adjacent the stationary press jaw 24, the compacted body then falling upon the return movement of the  
90 movable press jaw 25.

To receive the crushed or compacted aluminium can as it falls down from the press device, a  
95 perforated metal sheet 26 is supported by one arm 18, and when the arms 18 are in the crushing position shown in *Figure 3*, the sheet is held in a sloping position below the press device. Thus, the compacted body lands on, and will roll or slide down the sheet.  
100

A trough 27 is located below the receiving and press devices and forms an opening 28 in the bottom thereof, which is located such that the compacted body, moving down the sloping metal sheet 26 falls through the opening into a cardboard box or a bag (not shown) for receiving the compacted body placed inside the cabinet 10. Any residual liquid left in the can is pressed out during crushing and such  
105 liquid drains away to some extent when the can is in  
125  
130

a horizontal position on the cradle 22. The liquid draining off or being pressed out of the can in this manner flows onto the bottom 29 of the sloping trough 27 towards a drain tube 30 connected to a

5 container (not shown) for receiving the waste liquid.

It is, of course, important that a machine of the type referred to herein is constructed in such a way that bodily injuries cannot occur when the machine is being used, e.g. by a hand being introduced into

10 the press device during operation. The sliding cover 15 guards against a hand being placed through the receiving hopper 14 into the press device when the cradle 22 is in the crushing position and the press device is ready to operate. In the closed position the

15 slide cover 15 should be latched, and for this purpose an electromagnet 31 supported by the frame 21 of the machine is arranged to attract the rocker formed by the arms 18, when the cradle 22 is in the crushing position shown in Figure 3. If it

20 should occur due to a defectiveness in the operative systems of the machine, that the press device operates before the sliding cover 15 is completely closed and locked in the closed position, the cradle 22 is located between the press jaws 24 and 25 and

25 will prevent the jaws from closing. Therefore, the cradle should be so constructed as to be sufficiently sturdy to withstand the pressure of the movable press jaw 25.

It is also important that the machine cannot be

30 misused by inserting objects e.g. of glass or cardboard. To this end a sensor 32 is arranged adjacent the cradle 22. This sensor is of the inductive type for sensing non-magnetic metals. The sensor accordingly responds to aluminium cans and, of course,

35 also to cans of other non-magnetic metals, but it is unlikely that a can e.g. of copper, brass, stainless steel or the like will ever be placed in the machine. The sensor does not, however, respond to cardboard containers, cans of iron sheet, glass jars etc. A

40 suitable sensor for this purpose is VariKont (registered trade mark) available from Pepperl & Fuchs, Mannheim, BRD.

The hydraulic and electrical operating systems of the machine are generally and diagrammatically

45 shown in Figure 6. A hydraulic pump unit 33 is driven by an electric motor and can be of any suitable conventional construction. The pump unit is connected to a double-acting hydraulic cylinder 34, the piston rod of which supports the movable press

50 jaw 25 hydraulic conduits for the working motion and the return motion of the movable press jaw being shown at 35 and 36, respectively. In the hydraulic conduit 35 for the working motion there is arranged a pressure switch 37 for a predetermined

55 higher pressure, e.g. 400 kp, and a pressure switch 38 for a predetermined lower pressure, e.g. 100 kp. These pressure switches are both connected to a computer 39. Also, the electromagnet 31 and the sensor 32 are connected to the computer which is in

60 turn connected to the hydraulic pump unit 33 and to the printer 40. It can also be connected to indicators of different kinds as is indicated in Figure 6.

The computer 39 is programmed to provide, in co-operation with switches and functional units

65 connected therewith, the following operating cycle

of the machine.

When an aluminium can has been supplied to the can intake and has been positioned in the cradle 22 and when the cradle has been displaced to the

70 crushing position according to Figure 3, the sensor 32 supplies a signal to the computer 39 so that the computer energises the electromagnet 31 and starts the hydraulic pump unit 33. However, if the can supplied is not of aluminium (or another non-

75 magnetic metal) no "start" signal will be supplied to the pump unit 33. Possibly, starting of the pump unit may also be dependent on actuation of a responding contact 41 which supplies a signal to the computer 39 when the cradle 22 has arrived at the crushing

80 position shown in Figure 3. The contact 41 can be actuated by the rocker formed by the arms 18, or by an element connected with the rocker. The hydraulic cylinder 34 is then driven by the pump unit 33 to advance the movable press jaw 25 so that the can in

85 the cradle 22 is squeezed against the stationary press jaw 24. When the working stroke has been completed the hydraulic pressure in the hydraulic cylinder 34 is reversed in order that the movable press jaw 25 returns stroke to the rest position.

90 Movement of the movable press jaw 25 can be reversed in a known manner by means of limit switches or the like. When the movable press jaw 25 returns, the compacted body (the squeezed can) will fall down along the sloping perforated metal sheet

95 26 and the trough 27, through the opening 28 and into the bag or container.

If the can is made of aluminium (or another non-magnetic metal) nothing will happen in the machine; it will be necessary to remove the can again from the can intake so as to condition the intake for the supply of such cans as should be processed by the machine, viz. aluminium cans.

100

If the can supplied is filled or partly filled by liquid, stones, nails or the like, the applied pressure increases and eventually will reach the maximum value present in the pressure switch 37, the switch supplying a signal to the computer 39. The computer, in turn, by a signal to the pump unit, switches the hydraulic cylinder 34 for the immediate return of the

105 movable press jaw 25 to the rest position. Also in this case, it is accordingly necessary to remove the can from the can intake 12 in order that the machine will again operate normally.

The machine is constructed in such a way that an aluminium can is crushed to a height of e.g. 20 millimetres before the movable press jaw 25 returns. Some millimetres from the reversing position a limit switch 42 is arranged and this switch is connected to the computer 39 via the pressure switch 38 to

110 provide a signal only if the pressure preset in the pressure switch 38 has been reached. If this pressure is not reached, no signal is supplied to the computer. The signal from the limit switch 42 shall initiate a signal from the computer 39 to the printer 40 for counting the number of aluminium cans crushed in the machine. Due to the fact that the signal from the limit switch 42 is supplied to the computer 39 via the pressure switch 38 a relatively soft object e.g. a cardboard roll with an external aluminium foil will

125 not be counted as an aluminium can. Thus, it is

130

impossible to tamper with the machine in this summer. When one and the same customer has supplied the number of aluminium cans which are to be disposed of, the printer 40 will be started by depressing a push button 43, (see also Figure 1), for the supply of a printed tape from the printer. The tape is supplied from the machine at 44, Figure 1, and torn off in order that the slip obtained shall be used as a receipt for cans delivered. The printer can be of any conventional type. It should, of course, be zeroed after each depression of the push button 43.

The computer 39 should include necessary functions for providing an indication when the number of cans that have been processed in the machine corresponds to a filled collection bag or container, and for indicating that the tape in the printer has run out or that a defect has arisen in the machine. Neither the computer *per se* nor the details of these and other functions of the machine are described herein since there would be no difficulty involved at the present state of the computer art in constructing a computer with a programme which controls the functions described.

For example, alternative designs are possible for receiving the aluminium cans and transferring these cans to the crushing position. A rocker arrangement has been shown herein but it is possible to use instead a slide arrangement or the like. Also the trough 27 can be arranged in other ways than that shown herein, and this is, of course, true also of the construction and form of the cabinet 10.

Preferably, the can intake 12 should be so dimensioned that a can resting in the cradle 22, abuts the edge 44 if it is a few millimetres larger than a common aluminium can so that the can will be wiped off from the cradle 22 and cannot be delivered to the machine for crushing. Instead of the edge 44 being used as a wiper, a separate wiper can be arranged in the passageway between the receiving position of the cradle and the crushing position thereof.

## CLAIMS

1. A machine for crushing cylindrical aluminium cans, comprising a can intake and a press device for squeezing the cans axially between the end walls thereof, wherein a cradle for receiving the can in a substantially horizontal position is displaceable between a receiving position in the can intake and a crushing position in the press device by displacement of a closure member for the can intake between opened and closed position, and wherein a perforated sloping plane is arranged below the press device for receiving the crushed can falling from the press device at the return thereof after crushing and for diverting the crushed can to a collecting container.

2. A machine according to claim 1, wherein the perforated sloping plane is arranged in a hopper with an outlet opening connecting with the lower end of the perforated sloping plane and with a trough for receiving residual liquid from the can transferred to the press device, when being crushed in the press device.

3. A machine according to claim 2, wherein the trough has a drain connecting with a liquid container.

4. A machine according to any of claims 1 to 3, wherein the cradle is arranged on a rocker or a slide.

5. A machine according to claim 4, wherein the perforated sloping plane is arranged on the rocker or slide below the cradle to be displaced together with the cradle and to take a position below the press device with the cradle in the crushing position.

6. A machine according to any one of claims 1 to 5, wherein the cans are formed of aluminium and wherein a sensor responsive to aluminium, which is operatively connected to the control system of the press device, is arranged adjacent the crushing position of the press device to inhibit the operation thereof unless an aluminium can is located in the cradle when it is in the crushing position.

7. A machine according to any one of claims 1 to 6, wherein the press device is driven hydraulically from a hydraulic pump unit, the hydraulic system of which includes a pressure switch operatively connected to the control system of the press device for initiating the return movement of the device at a predetermined higher pressure at the crushing operation.

8. A machine according to claim 7, wherein a further pressure switch is arranged in the hydraulic system to inhibit the signal from the sensor at a pressure in the hydraulic system which is below a predetermined lower pressure.

9. A machine for crushing cans constructed and arranged substantially as hereinbefore described with reference to and as illustrated in the accompanying drawings.