

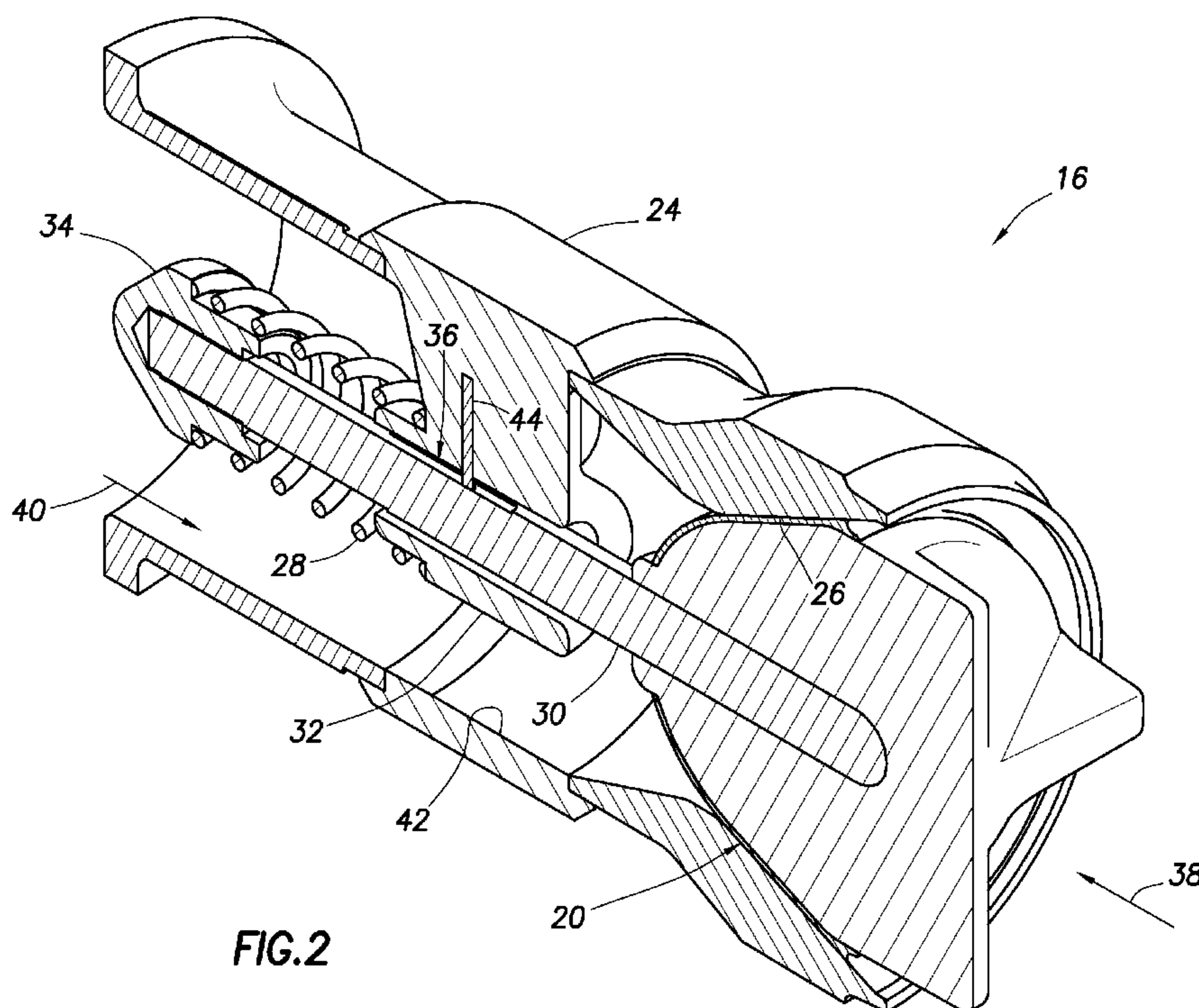

(86) **Date de dépôt PCT/PCT Filing Date:** 2014/08/12
 (87) **Date publication PCT/PCT Publication Date:** 2016/02/18
 (85) **Entrée phase nationale/National Entry:** 2016/12/15
 (86) **N° demande PCT/PCT Application No.:** US 2014/050619
 (87) **N° publication PCT/PCT Publication No.:** 2016/024948

(51) **Cl.Int./Int.Cl. E21B 34/06** (2006.01),
E21B 34/08 (2006.01)
 (71) **Demandeur/Applicant:**
HALLIBURTON ENERGY SERVICES, INC., US
 (72) **Inventeurs/Inventors:**
MERICAS, CHRISTOPHER J., US;
BUDLER, NICHOLAS F., US
 (74) **Agent:** PARLEE MCLAWS LLP

(54) **Titre : SOUPE A FLOTTEUR A REMPLISSAGE AUTOMATIQUE REINITIALISABLE**
 (54) **Title: FLOAT VALVE WITH RESETTABLE AUTO-FILL**



(57) **Abrégé/Abstract:**

A float valve can include a selection mechanism having an open configuration in which flow into and out of the valve is permitted, and a closed configuration in which flow out of the valve is permitted and flow into the valve is prevented. The selection mechanism



(57) Abrégé(suite)/Abstract(continued):

can be actuated from the closed configuration to the open configuration. A method of actuating a float valve can include actuating the valve from a closed configuration in which flow into the valve is prevented but flow out of the valve is permitted, to an open configuration in which flow into and out of the valve is permitted. The valve can actuate from the open configuration to the closed configuration, and from the closed to the open configuration, in response to a flow rate through the valve being greater than a predetermined level.

(12) INTERNATIONAL APPLICATION PUBLISHED UNDER THE PATENT COOPERATION TREATY (PCT)

(19) World Intellectual Property
Organization
International Bureau(10) International Publication Number
WO 2016/024948 A1(43) International Publication Date
18 February 2016 (18.02.2016)

(51) International Patent Classification:

E21B 34/06 (2006.01) *E21B 34/08* (2006.01)

(21) International Application Number:

PCT/US2014/050619

(22) International Filing Date:

12 August 2014 (12.08.2014)

(25) Filing Language:

English

(26) Publication Language:

English

(71) Applicant: **HALLIBURTON ENERGY SERVICES, INC.** [US/US]; 3000 North Sam Houston Parkway East, Houston, TX 77032 (US).(72) Inventors: **MERICAS, Christopher, J.**; 14524 Heathrow Forrest Parkway, Houston, TX 77032 (US). **BUDLER, Nicholas, F.**; 6540 East Apache Street, Tulsa, OK 74115 (US).(74) Agent: **SCHEER, Bradley, W.**; Schwegman Lundberg & Woessner, P.A., P.O. Box 2938, Minneapolis, MN 55402 (US).(81) Designated States (*unless otherwise indicated, for every kind of national protection available*): AE, AG, AL, AM, AO, AT, AU, AZ, BA, BB, BG, BH, BN, BR, BW, BY, BZ, CA, CH, CL, CN, CO, CR, CU, CZ, DE, DK, DM,

DO, DZ, EC, EE, EG, ES, FI, GB, GD, GE, GH, GM, GT, HN, HR, HU, ID, IL, IN, IR, IS, JP, KE, KG, KN, KP, KR, KZ, LA, LC, LK, LR, LS, LT, LU, LY, MA, MD, ME, MG, MK, MN, MW, MX, MY, MZ, NA, NG, NI, NO, NZ, OM, PA, PE, PG, PH, PL, PT, QA, RO, RS, RU, RW, SA, SC, SD, SE, SG, SK, SL, SM, ST, SV, SY, TH, TJ, TM, TN, TR, TT, TZ, UA, UG, US, UZ, VC, VN, ZA, ZM, ZW.

(84) Designated States (*unless otherwise indicated, for every kind of regional protection available*): ARIPO (BW, GH, GM, KE, LR, LS, MW, MZ, NA, RW, SD, SL, SZ, TZ, UG, ZM, ZW), Eurasian (AM, AZ, BY, KG, KZ, RU, TJ, TM), European (AL, AT, BE, BG, CH, CY, CZ, DE, DK, EE, ES, FI, FR, GB, GR, HR, HU, IE, IS, IT, LT, LU, LV, MC, MK, MT, NL, NO, PL, PT, RO, RS, SE, SI, SK, SM, TR), OAPI (BF, BJ, CF, CG, CI, CM, GA, GN, GQ, GW, KM, ML, MR, NE, SN, TD, TG).

Declarations under Rule 4.17:

- *as to applicant's entitlement to apply for and be granted a patent (Rule 4.17(ii))*
- *of inventorship (Rule 4.17(iv))*

Published:

- *with international search report (Art. 21(3))*

(54) Title: FLOAT VALVE WITH RESETTABLE AUTO-FILL

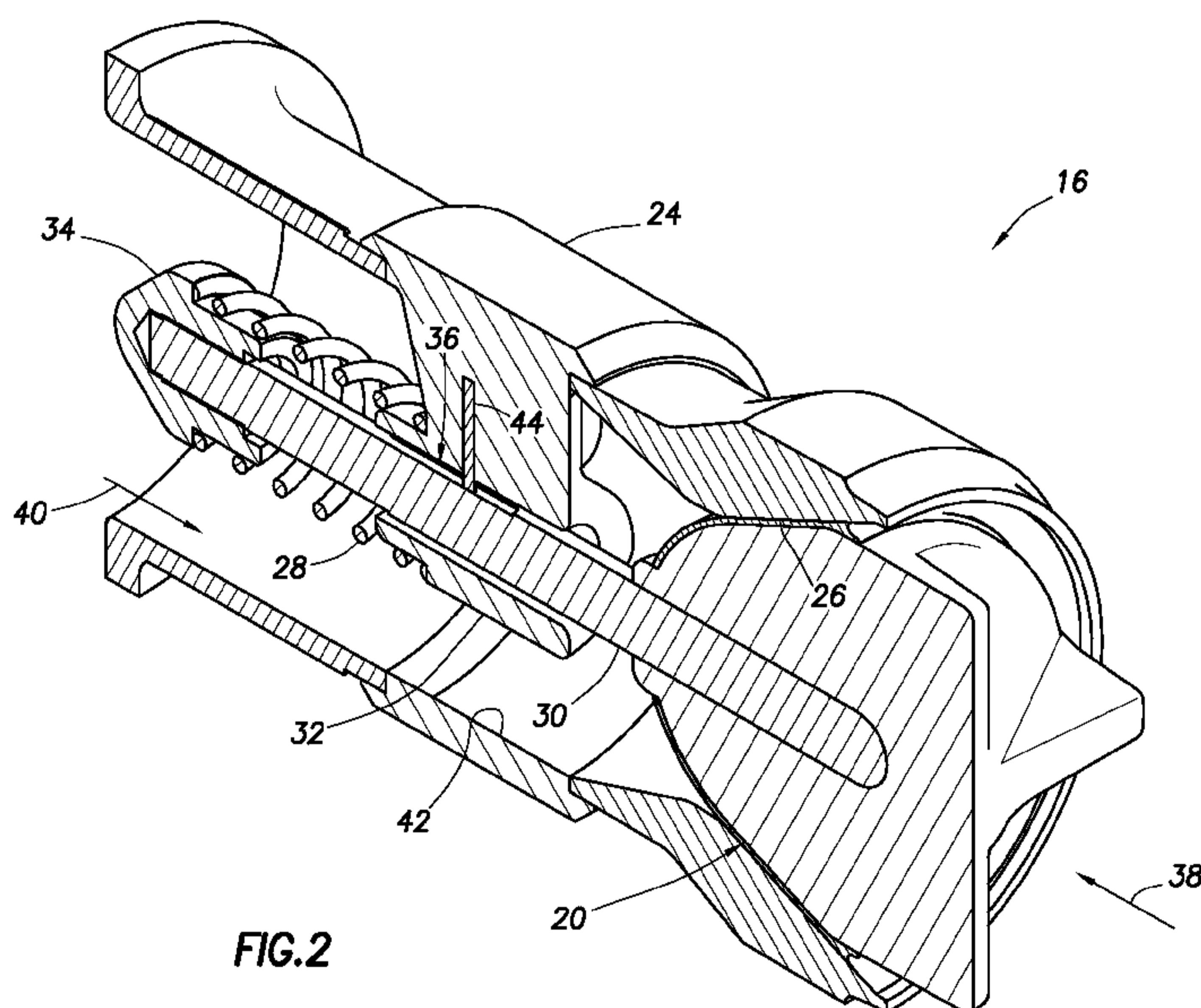

FIG.2

(57) Abstract: A float valve can include a selection mechanism having an open configuration in which flow into and out of the valve is permitted, and a closed configuration in which flow out of the valve is permitted and flow into the valve is prevented. The selection mechanism can be actuated from the closed configuration to the open configuration. A method of actuating a float valve can include actuating the valve from a closed configuration in which flow into the valve is prevented but flow out of the valve is permitted, to an open configuration in which flow into and out of the valve is permitted. The valve can actuate from the open configuration to the closed configuration, and from the closed to the open configuration, in response to a flow rate through the valve being greater than a predetermined level.

5

FLOAT VALVE WITH RESETTABLE AUTO-FILL**TECHNICAL FIELD**

10 This disclosure relates generally to equipment utilized and operations performed in conjunction with a subterranean well and, in one example described below, more particularly provides a float valve with a resettable auto-fill feature.

15

BACKGROUND

A typical float valve can permit cement to be flowed out of a casing string and into an annulus formed between the casing string and a wellbore. The float valve prevents the cement from flowing back into the casing string. While
20 the casing string is being installed in the wellbore, some float valves have an auto-fill feature that allows fluid in the wellbore to flow through the valve into the casing string, so that the casing string does not have to be filled from surface as it is installed.

25

Thus, it will be readily appreciated that improvements are continually needed in the art of constructing and operating float valves. Such improved float valves may be used in cementing and other operations in wells.

- 2 -

BRIEF DESCRIPTION OF THE DRAWINGS

FIG. 1 is a representative partially cross-sectional view of a well system and associated method which can embody principles of this disclosure.

5 FIG. 2 is a representative enlarged scale cross-sectional view of a float valve that can be used in the system and method of FIG. 1, and which can embody the principles of this disclosure.

10 FIG. 3 is a representative further enlarged scale perspective view of a stem of the float valve.

FIG. 4 is a representative cross-sectional view of the float valve in a closed configuration.

FIG. 5 is a representative cross-sectional view of the float valve during flow rate actuation thereof.

15 FIG. 6 is a representative cross-sectional view of the float valve in an open configuration.

DETAILED DESCRIPTION

Representatively illustrated in FIG. 1 is a system 10
20 for use with a well, and an associated method, which system and method can embody principles of this disclosure. However, it should be clearly understood that the system 10 and method are merely one example of an application of the principles of this disclosure in practice, and a wide
25 variety of other examples are possible. Therefore, the scope of this disclosure is not limited at all to the details of the system 10 and method described herein and/or depicted in the drawings.

In the FIG. 1 example, a casing string 12 is being
30 installed and cemented in a wellbore 14. As used herein, the

- 3 -

terms "casing," "casing string," and the like, refer to a generally tubular protective wellbore lining. Casing may be of the types known to those skilled in the art as casing, liner or tubing. Casing may be made of metal or other materials, and may be continuous or segmented.

As used herein, the terms "cement," "cementing," and the like, refer to a hardenable material that is flowed into an annulus between a casing string and a wellbore (or another casing string) and hardens in the annulus. When hardened, the cement secures the casing string in the wellbore and can perform other functions, such as, preventing flow through the annulus between zones penetrated by the wellbore, preventing undesired leakage into or out of the casing string, etc.

Cement is not necessarily a cementitious material. For example, epoxies or other hardenable polymer materials may be used for cementing. However, it should be clearly understood that the scope of this disclosure is not limited to use with a cementing operation, or any other particular operation, in a well.

As depicted in FIG. 1, the casing string 12 includes a float valve 16. The float valve 16 is connected at a lower distal end of the casing string 12 in this example, but in other examples the float valve could be connected at another position in the casing string.

The float valve 16 permits flow of fluid 18 longitudinally through the casing string 12, and out of the casing string into the wellbore 14 via the valve. While the casing string 12 is being installed, the fluid 18 may be circulated through the casing string and an annulus 20 formed between the casing string and the wellbore 14 for various purposes (for example, to wash the casing string

- 4 -

past an obstruction, to treat the wellbore with a fluid loss control agent, to prevent sticking, to maintain a desired fluid density in the wellbore, etc.).

After the casing string 12 has been appropriately
5 positioned in the wellbore 14, the fluid 18 can comprise cement, spacers, gels and/or other materials. In general, in a cementing operation, it is desired to place the cement in the annulus 20, and to allow the cement to harden in the annulus, thereby securing the casing string 12 in the
10 wellbore 14.

The fluid 18 can also flow in a reverse direction from that depicted in FIG. 1. For example, while the casing string 12 is being installed, the fluid in the wellbore 14 can flow into the casing string via the float valve 16. This
15 feature is known to those skilled in the art as an "auto-fill" feature, because it allows a casing string to automatically fill with fluid as it is installed in a wellbore.

However, in a typical float valve construction, the
20 auto-fill feature can only be used once. After the auto-fill feature is disabled, fluid can only exit the casing string-- fluid can no longer enter the casing string via the valve. In contrast, the float valve 16 of FIG. 1 includes a resettable auto-fill feature, so that the auto-fill feature
25 can be enabled multiple times.

Note that the float valve 16 also includes a variety of other features, described more fully below. It should be clearly understood that the scope of this disclosure is not limited to any particular feature or combination of features
30 in the float valve 16 described herein or depicted in the drawings.

- 5 -

Referring additionally now to FIG. 2, an enlarged scale cross-sectional view of the float valve 16 is representatively illustrated. The float valve 16 of FIG. 2 may be used in the system and method of FIG. 1, or it may be used in other systems and methods in keeping with the principles of this disclosure.

Only certain components of the float valve 16 are depicted in FIG. 2. In practice, an assembly depicted in FIG. 2 may be received in an outer housing (not shown) configured for connection in the casing string 12 (see FIG. 1). For example, a cement or other relatively easily drillable material (not shown) may be used to secure the FIG. 2 assembly in an outer housing.

The various components of the FIG. 2 assembly may be made of relatively easily drilled materials (such as, aluminum, brass, elastomers, other polymers, etc.). In this manner, the float valve 16 can be drilled through, if desired, after the casing string 12 (see FIG. 1) has been cemented.

In the FIG. 2 example, the float valve 16 includes a closure device 22 reciprocally received in an inner housing assembly 24. A generally conical seat 26 is formed in one end of the inner housing assembly 24.

The closure device 22 is biased toward the seat 26 by a biasing device 28, depicted as a coiled spring in FIG. 2. A stem 30 of the closure device 22 extends through an inner support 32 and through the biasing device 28. A retainer 34 on the stem 30 is configured to allow the biasing device 28 to be compressed between the support 32 and the retainer.

A selection mechanism 36 is used to control displacement of the closure device 20 relative to the housing assembly 24 and its seat 26. In the FIG. 2 closed

- 6 -

configuration, the selection mechanism 36 allows the biasing device 28 to displace the closure device 20 into sealing engagement with the seat 26, thereby preventing flow into the valve 16 (e.g., in a longitudinal direction 38).

5 However, in the closed configuration, longitudinal flow out of the valve 16 (e.g., in a longitudinal direction 40) is permitted, since the biasing device 28 can be compressed to allow the closure device 20 to disengage from the seat 26. Thus, flow through a longitudinal passage 42 of the
10 valve 16 is permitted in one direction 40, but is prevented in an opposite direction 38.

The valve 16 can be actuated to the FIG. 2 closed configuration, for example, during the cementing operation described above, in order to prevent reverse flow of cement
15 into the casing string 12 (see FIG. 1). This ensures that cement placed in the annulus 20 (see FIG. 1) will remain in position while it hardens.

The selection mechanism 36 in the FIG. 2 example includes a pin, lug, protrusion or other engagement member
20 44 and a profile 46. The engagement member 44 extends inwardly from the support 32 into engagement with the profile 46 formed on the stem 30, as depicted in FIG. 2, but in other examples these positions could be reversed. Indeed, other types of selection mechanisms could be used, and so
25 the scope of this disclosure is not limited at all to any of the specific details of the selection mechanism 36 or other components of the valve 16 described herein or depicted in the drawings.

The selection mechanism 36 allows the valve 16 to be
30 actuated to an open configuration (see FIG. 6), in which flow into and out of the valve (e.g., in both longitudinal directions 38, 40) is permitted. In the open configuration,

- 7 -

the selection mechanism 36 maintains the closure device 20 spaced apart from the seat 26, preventing the biasing device 28 from displacing the closure device into sealing engagement with the seat.

5 Referring additionally now to FIG. 3, a further enlarged scale perspective view of the stem 30 is representatively illustrated, apart from the remainder of the valve 16. In this view, the profile 46 formed on the stem 30 can be more clearly seen.

10 Although the profile 46 depicted in FIG. 3 includes multiple separate circumferentially spaced sections, in some examples the profile can be continuous, as with the type of profile known to those skilled in the art as a "J-slot" profile. In other examples, the profile 46 could be
15 configured similar to the type of profile found in a conventional push-button retractable writing pen (see, for example, U.S. patent no. 3819282). Thus, the scope of this disclosure is not limited to use of any particular type of profile in the selection mechanism 36.

20 The profile 46 provides for a first position 44a of the engagement member (see FIG. 2) relative to the profile, and a second position 44b of the engagement member relative to the profile. When the engagement member 44 is at the first position 44a, the biasing device 28 can displace the closure
25 device 20 into sealing engagement with the seat 26, and the valve 16 is in the closed configuration of FIG. 2. When the engagement member 44 is at the second position 44b, the selection mechanism 36 prevents the biasing device 28 from displacing the closure device 20 into sealing engagement
30 with the seat 26, and the valve 16 is in the open configuration of FIG. 6.

- 8 -

The profile 46 example of FIG. 3 provides for multiple closed positions 44a and multiple open positions 44b. In this manner, the valve 16 can be actuated to its closed and open configurations multiple times, as described more fully
5 below.

To longitudinally displace the stem 30, so that the engagement member 44 can engage the profile 46 at the different positions 44a,b, fluid flow through the passage 42 (see FIG. 2) is selectively increased and decreased, as
10 described more fully below. To rotate the stem 30, so that the engagement member 44 can engage the profile 46 at the different positions 44a,b, the biasing device 28 or another device (such as, a torsion spring, a second set of engagement members and profiles as in a retractable pen
15 mechanism, an inclined portion of a J-slot profile, etc.) can be used.

Referring additionally now to FIGS. 4-6, cross-sectional views of the valve 16 being actuated between the closed and open configurations are representatively
20 illustrated. FIGS. 4-6 depict the valve 16 being actuated from the closed configuration to the open configuration, but it should be clearly understood that the valve can also be actuated from the open configuration to the closed configuration. In some examples, these actuations can be
25 repeated multiple times (e.g., by providing multiple positions 44a,b), and in some examples these actuations can be repeated indefinitely.

In FIG. 4, the valve 16 is in the closed configuration. The closure device 20 is sealingly engaged with the seat 26.
30 The engagement member 44 is at the first position 44a (see FIG. 3) in the profile 46. Flow into the passage 42 (e.g.,

- 9 -

in the direction 38) is prevented. Flow out of the passage 42 (e.g., in the direction 40) is permitted.

In FIG. 5, flow in the direction 40 is increased to at least a predetermined flow rate level. This level can be
5 adjusted, for example, by adjusting a biasing force exerted by the biasing device 28. The flow causes the closure device 20 to displace longitudinally, compressing the biasing device 28, and causing the stem 30 to rotate, so that the engagement member 44 is aligned with a next section of the
10 profile 46 (see FIG. 3).

In FIG. 6, the valve 16 is in the open configuration. The closure device 20 is spaced apart from the seat 26. The engagement member 44 is at the second position 44b (see FIG. 3) in the profile 46. Flow into and out of the passage 42
15 (e.g., in the directions 38, 40) is permitted.

The valve 16 can be returned to the open configuration of FIG. 4 by again increasing flow in the direction 40 to at least the predetermined flow rate level. The flow causes the closure device 20 to displace longitudinally, compressing
20 the biasing device 28, and causing the stem 30 to rotate, so that the engagement member 44 is aligned with a next section of the profile 46 (see FIG. 3) corresponding to the open configuration.

The above steps can be repeated as many times as the
25 chosen configuration/number of profile 46 sections and engagement member(s) 44 allows, or indefinitely in some examples. Thus, the valve 16 can be actuated to the open configuration from the closed configuration, and can be actuated to the closed configuration from the open
30 configuration, allowing the auto-fill feature to be reset downhole, if desired.

- 10 -

One feature of the selection mechanism 36 configuration described above is that it provides for convenient assembly of the valve 16. For example, the stem 30 can be inserted through the inner support 32, thereby engaging the engagement member 44 with the profile 46, prior to installing the biasing device 28. There is no need to compress the biasing device 28 while the selection mechanism 36 is assembled. However, as mentioned above, different types of selection mechanisms may be used in other examples.

It may now be fully appreciated that the above disclosure provides significant advancements to the art of constructing and operating float valves. A float valve 16 example described above and depicted in the drawings has a resettable auto-fill feature, enabling the valve to be actuated back and forth between open and closed configurations.

In particular, the above disclosure provides to the art a float valve 16. In one example, the valve 16 can include a selection mechanism 36 having an open configuration (see FIG. 6) in which flow into and out of the valve 16 is permitted, and a closed configuration (see FIGS. 2 & 4) in which flow out of the valve 16 is permitted and flow into the valve 16 is prevented. The selection mechanism 36 can be actuated from the closed configuration to the open configuration.

The selection mechanism 36 can be actuated from the open configuration to the closed configuration in response to a flow rate through the valve 16 being greater than a first predetermined level, and the selection mechanism 36 can be actuated from the closed configuration to the open configuration in response to the flow rate through the valve 16 being greater than a second predetermined level. The

- 11 -

first and second predetermined levels may be substantially equal.

The selection mechanism 36 can comprise an engagement member 44 engaged with a profile 46, the selection mechanism 5 36 being in the closed configuration when the engagement member 44 is engaged with the profile at a first position 44a, and the selection mechanism 36 being in the open configuration when the engagement member 44 is engaged with the profile 46 at a second position 44b. The profile 46 can 10 comprise multiple first and second positions 44a,b.

The float valve 16 can include a seat 26 and a closure device 20 including a stem 30. Longitudinal flow through the valve 16 is prevented when the closure device 20 is sealingly engaged with the seat 26. Longitudinal flow 15 through the valve 16 is permitted when the closure device 20 is spaced apart from the seat 26 by the selection mechanism 36.

In this example, the selection mechanism 36 can comprise an engagement member 44 engaged with a profile 46 20 formed on the stem 30. The engagement member 44 may engage the profile 46 in both of the open and closed configurations of the selection mechanism 36.

The above disclosure also provides to the art a method of actuating a float valve 16. In one example, the method 25 can comprise actuating the valve 16 from a closed configuration in which flow into the valve is prevented but flow out of the valve is permitted, to an open configuration in which flow into and out of the valve 16 is permitted.

The actuating step may be performed multiple times. The 30 actuating step may be performed by flowing through the valve 16 at greater than a predetermined flow rate.

- 12 -

The method can include actuating the valve 16 from the open configuration to the closed configuration. The method can include actuating the valve 16 from the open configuration to the closed configuration multiple times.

5 The method can include actuating the valve 16 from the open configuration to the closed configuration by flowing through the valve at greater than a predetermined flow rate.

The actuating step can include causing relative displacement between an engagement member 44 and a profile 10 46 of a selection mechanism 36.

A well system 10 is also provided to the art by the above disclosure. In one example, the system 10 can include a float valve 16 connected to a casing string 12, the valve 16 having an open configuration in which flow into and out 15 of the casing string 12 through the valve 16 is permitted, and a closed configuration in which flow out of the casing string 12 through the valve 16 is permitted and flow into the casing string 12 through the valve 16 is prevented. The valve 16 actuates from the open configuration to the closed 20 configuration in response to a flow rate through the valve 16 being greater than a first predetermined level, and the valve 16 actuates from the closed configuration to the open configuration in response to the flow rate through the valve 16 being greater than a second predetermined level.

25 The first and second predetermined levels can be the same.

The valve 16 can comprise an engagement member 44 engaged with a profile 46, the valve 16 being in the closed configuration when the engagement member 44 is engaged with the profile 46 at a first position 44a, and the valve 16 30 being in the closed configuration when the engagement member 44 is engaged with the profile 46 at a second position 44b.

- 13 -

Although various examples have been described above, with each example having certain features, it should be understood that it is not necessary for a particular feature of one example to be used exclusively with that example.

5 Instead, any of the features described above and/or depicted in the drawings can be combined with any of the examples, in addition to or in substitution for any of the other features of those examples. One example's features are not mutually exclusive to another example's features. Instead, the scope

10 of this disclosure encompasses any combination of any of the features.

Although each example described above includes a certain combination of features, it should be understood that it is not necessary for all features of an example to

15 be used. Instead, any of the features described above can be used, without any other particular feature or features also being used.

It should be understood that the various embodiments described herein may be utilized in various orientations,

20 such as inclined, inverted, horizontal, vertical, etc., and in various configurations, without departing from the principles of this disclosure. The embodiments are described merely as examples of useful applications of the principles of the disclosure, which is not limited to any specific

25 details of these embodiments.

The terms "including," "includes," "comprising," "comprises," and similar terms are used in a non-limiting sense in this specification. For example, if a system, method, apparatus, device, etc., is described as "including"

30 a certain feature or element, the system, method, apparatus, device, etc., can include that feature or element, and can also include other features or elements. Similarly, the term

- 14 -

"comprises" is considered to mean "comprises, but is not limited to."

Of course, a person skilled in the art would, upon a careful consideration of the above description of
5 representative embodiments of the disclosure, readily appreciate that many modifications, additions, substitutions, deletions, and other changes may be made to the specific embodiments, and such changes are contemplated by the principles of this disclosure. For example,
10 structures disclosed as being separately formed can, in other examples, be integrally formed and *vice versa*. Accordingly, the foregoing detailed description is to be clearly understood as being given by way of illustration and example only, the spirit and scope of the invention being
15 limited solely by the appended claims and their equivalents.

- 15 -

WHAT IS CLAIMED IS:

1. A float valve, comprising:

5 a selection mechanism having an open configuration in which flow into and out of the valve is permitted, and a closed configuration in which flow out of the valve is permitted and flow into the valve is prevented, and

wherein the selection mechanism actuates from the closed configuration to the open configuration.

10

2. The float valve of claim 1, wherein the selection mechanism actuates from the open configuration to the closed configuration in response to a flow rate through the valve being increased, and wherein the selection mechanism
15 actuates from the closed configuration to the open configuration in response to the flow rate through the valve being increased.

3. The float valve of claim 2, wherein each of the
20 flow rate increases comprises an increase in flow out of the valve.

4. The float valve of claim 1, wherein the selection mechanism comprises an engagement member engaged with a
25 profile, the selection mechanism being in the closed configuration when the engagement member is engaged with the profile at a first position, and the selection mechanism being in the open configuration when the engagement member is engaged with the profile at a second position.

30

- 16 -

5. The float valve of claim 4, wherein the profile comprises a plurality of the first and second positions.

6. The float valve of claim 1, further comprising a
5 seat and a closure device including a stem, wherein
longitudinal flow through the valve is prevented when the
closure device is sealingly engaged with the seat, wherein
longitudinal flow through the valve is permitted when the
closure device is spaced apart from the seat by the
10 selection mechanism, and wherein the selection mechanism
comprises an engagement member engaged with a profile formed
on the stem.

7. The float valve of claim 1, wherein the selection
15 mechanism comprises an engagement member engaged with a
profile, and wherein the engagement member engages the
profile in both of the open and closed configurations of the
selection mechanism.

- 17 -

8. A method of actuating a float valve, the method comprising:

actuating the valve in a well from a closed configuration in which flow into the valve is prevented but
5 flow out of the valve is permitted, to an open configuration in which flow into and out of the valve is permitted.

9. The method of claim 8, wherein the actuating is performed multiple times.

10

10. The method of claim 8, wherein the actuating is performed by flowing through the valve at greater than a predetermined flow rate.

15

11. The method of claim 8, further comprising actuating the valve from the open configuration to the closed configuration.

20

12. The method of claim 8, further comprising actuating the valve from the open configuration to the closed configuration multiple times.

25

13. The method of claim 8, further comprising actuating the valve from the open configuration to the closed configuration by flowing through the valve at greater than a predetermined flow rate.

WO 2016/024948

PCT/US2014/050619

- 18 -

14. The method of claim 8, wherein the actuating comprises causing relative displacement between an engagement member and a profile of a selection mechanism.

- 19 -

15. A well system, comprising:

a float valve connected to a casing string in a well,
the valve having an open configuration in which flow into
and out of the casing string through the valve is permitted,
5 and a closed configuration in which flow out of the casing
string through the valve is permitted and flow into the
casing string through the valve is prevented,

wherein the valve actuates from the open configuration
to the closed configuration in response to a flow rate
10 through the valve being increased, and

wherein the valve actuates from the closed
configuration to the open configuration in response to the
flow rate through the valve being increased.

15 16. The well cementing system of claim 15, wherein
each of the flow rate increases comprises an increase in
flow out of the valve.

20 17. The well cementing system of claim 15, wherein the
valve comprises an engagement member engaged with a profile,
the valve being in the closed configuration when the
engagement member is engaged with the profile at a first
position, and the valve being in the open configuration when
the engagement member is engaged with the profile at a
25 second position.

18. The well cementing system of claim 17, wherein the
profile comprises a plurality of the first and second
positions.

30

- 20 -

19. The well cementing system of claim 15, wherein the valve comprises a seat and a closure device including a stem, wherein longitudinal flow through the valve is prevented when the closure device is sealingly engaged with the seat, wherein longitudinal flow through the valve is permitted when the closure device is spaced apart from the seat, and wherein the valve further comprises an engagement member engaged with a profile formed on the stem.

20. The well cementing system of claim 15, wherein the valve comprises a selection mechanism including an engagement member engaged with a profile, and wherein the engagement member engages the profile in both of the open and closed configurations of the valve.

15

1/6

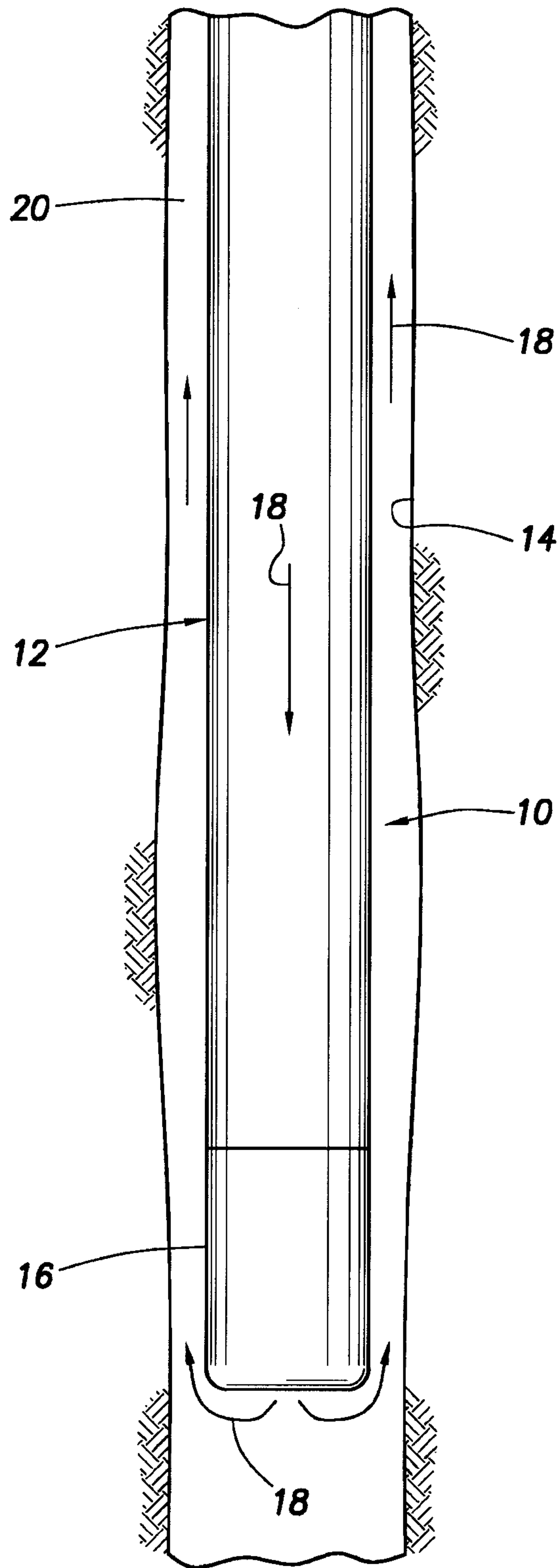

FIG. 1

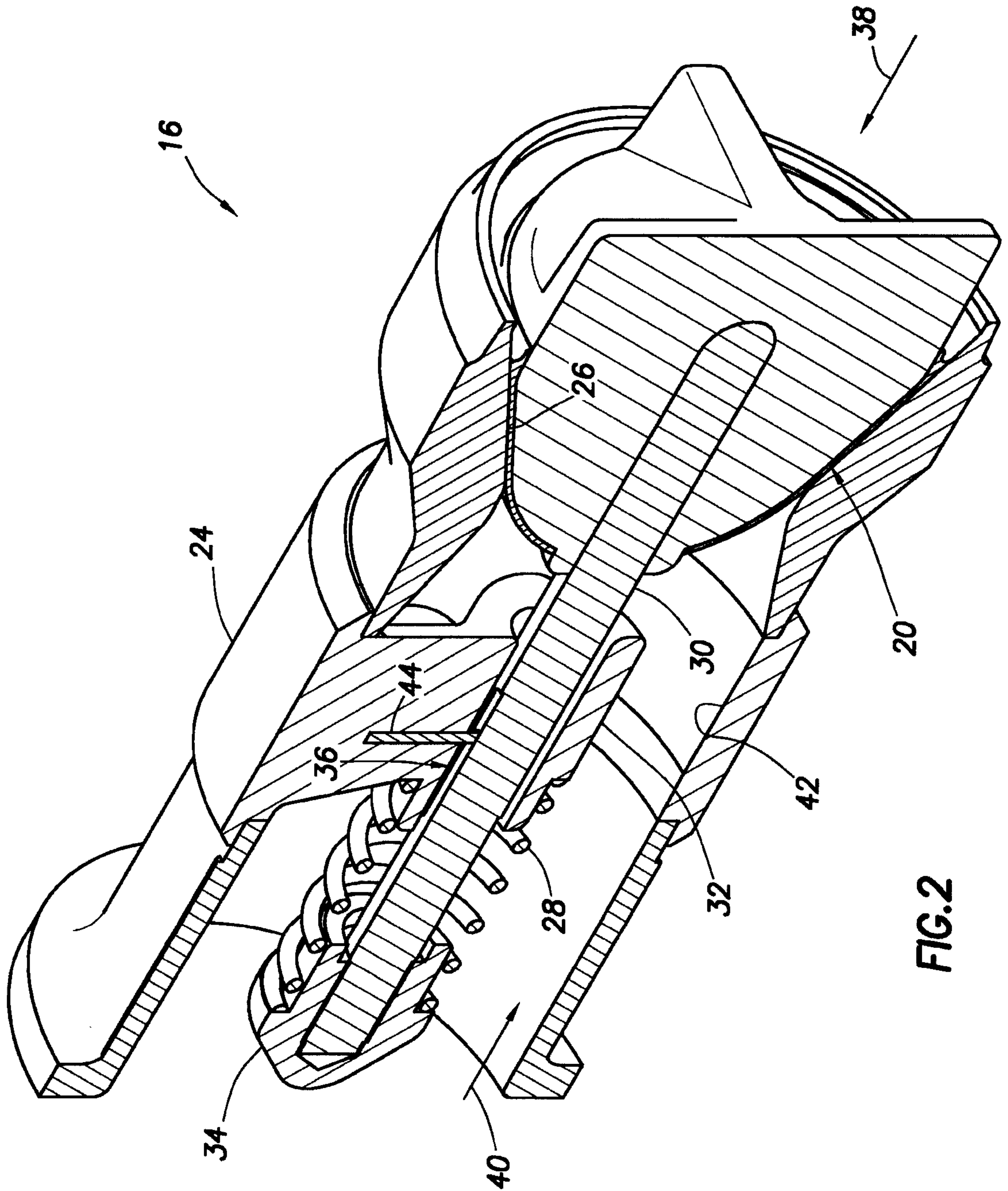

FIG. 2

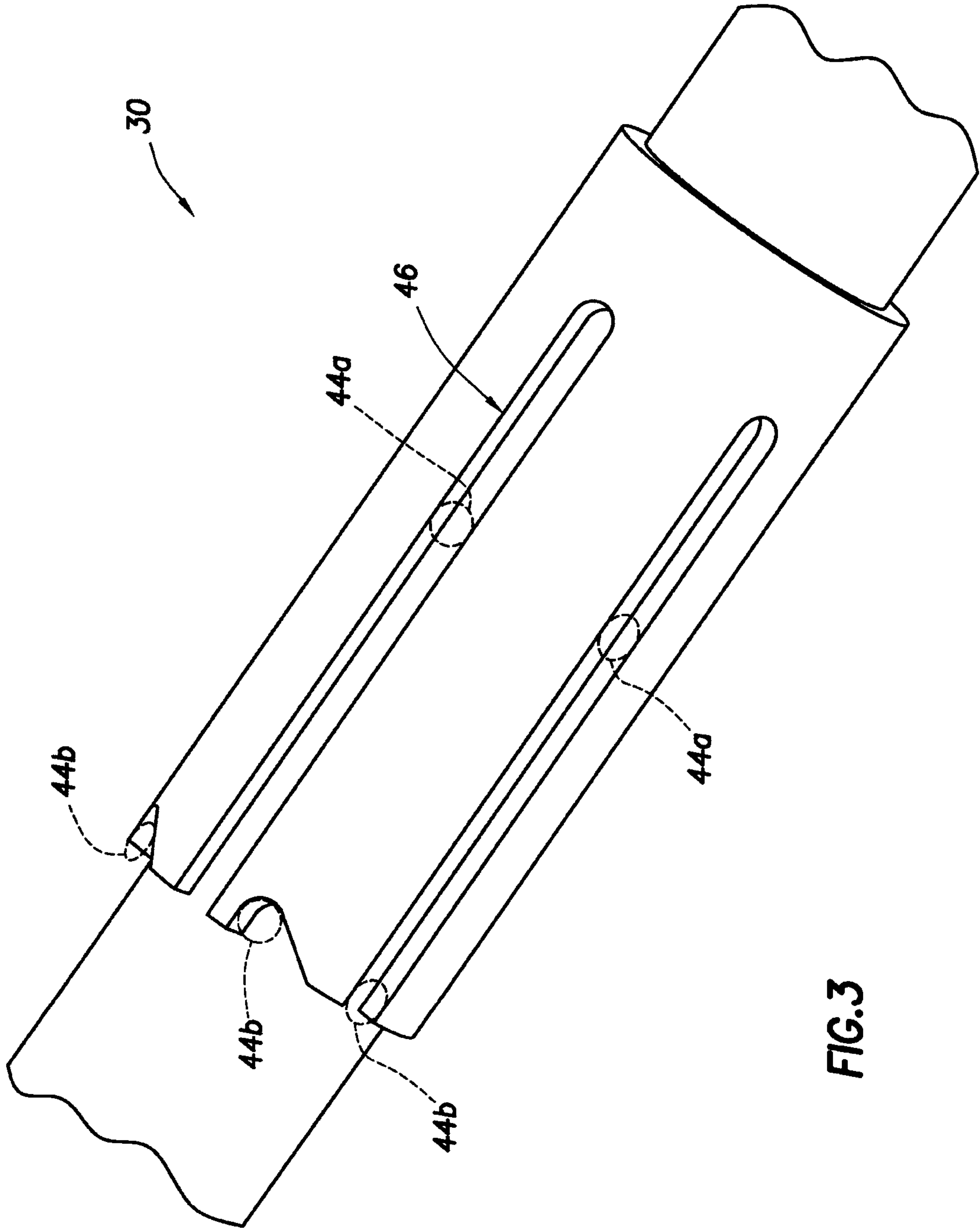

FIG.3

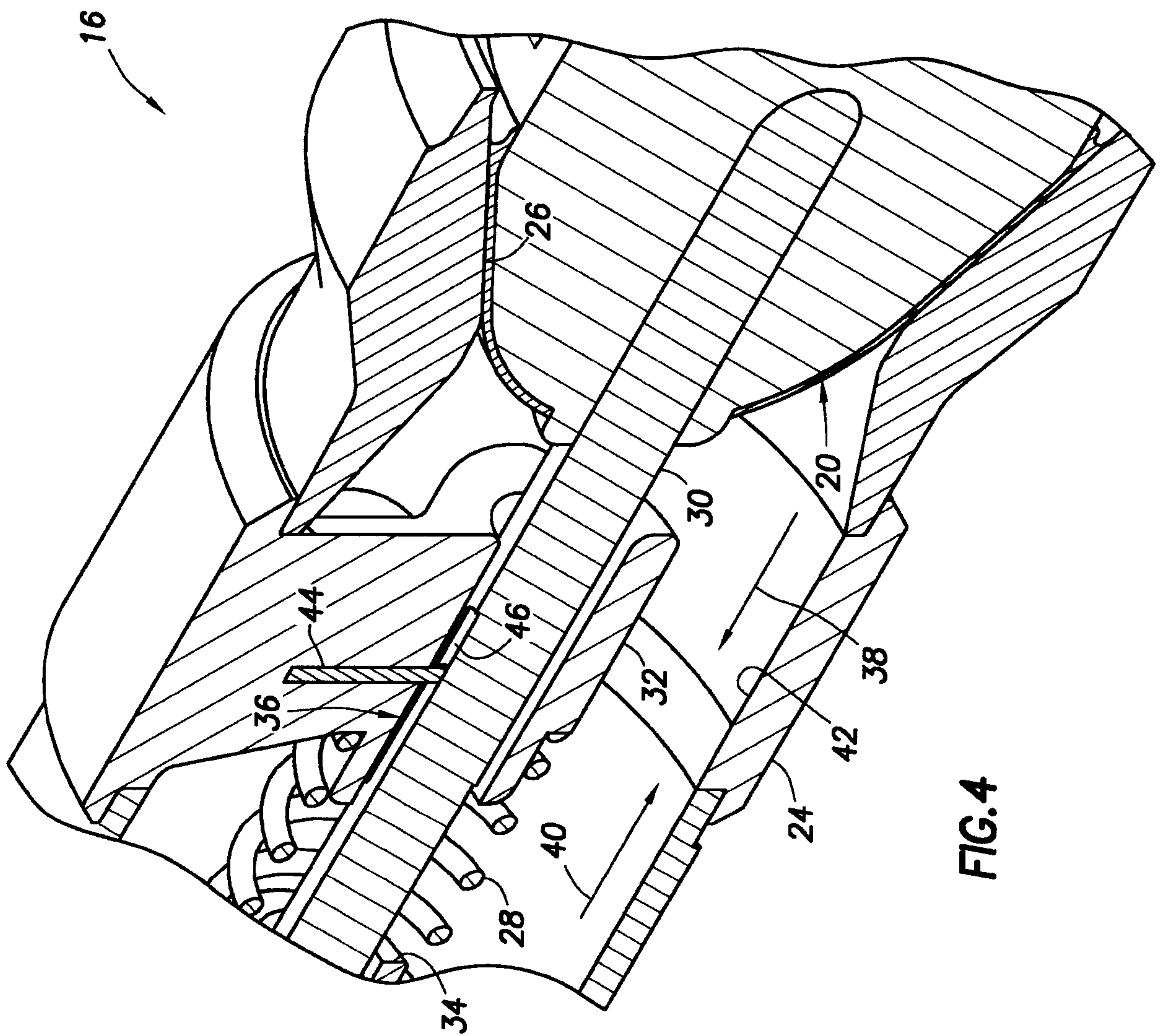

FIG. 4

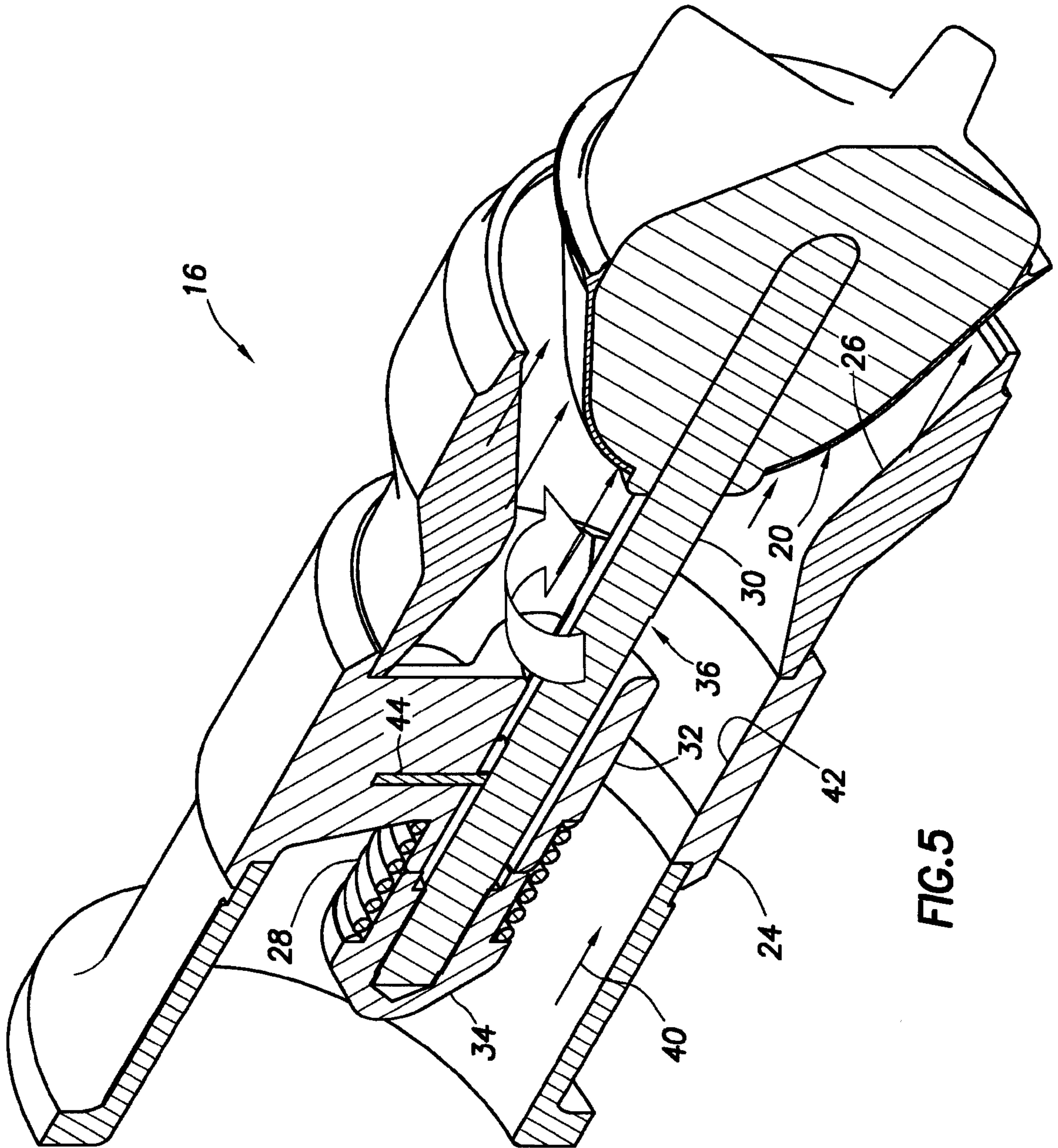

FIG. 5

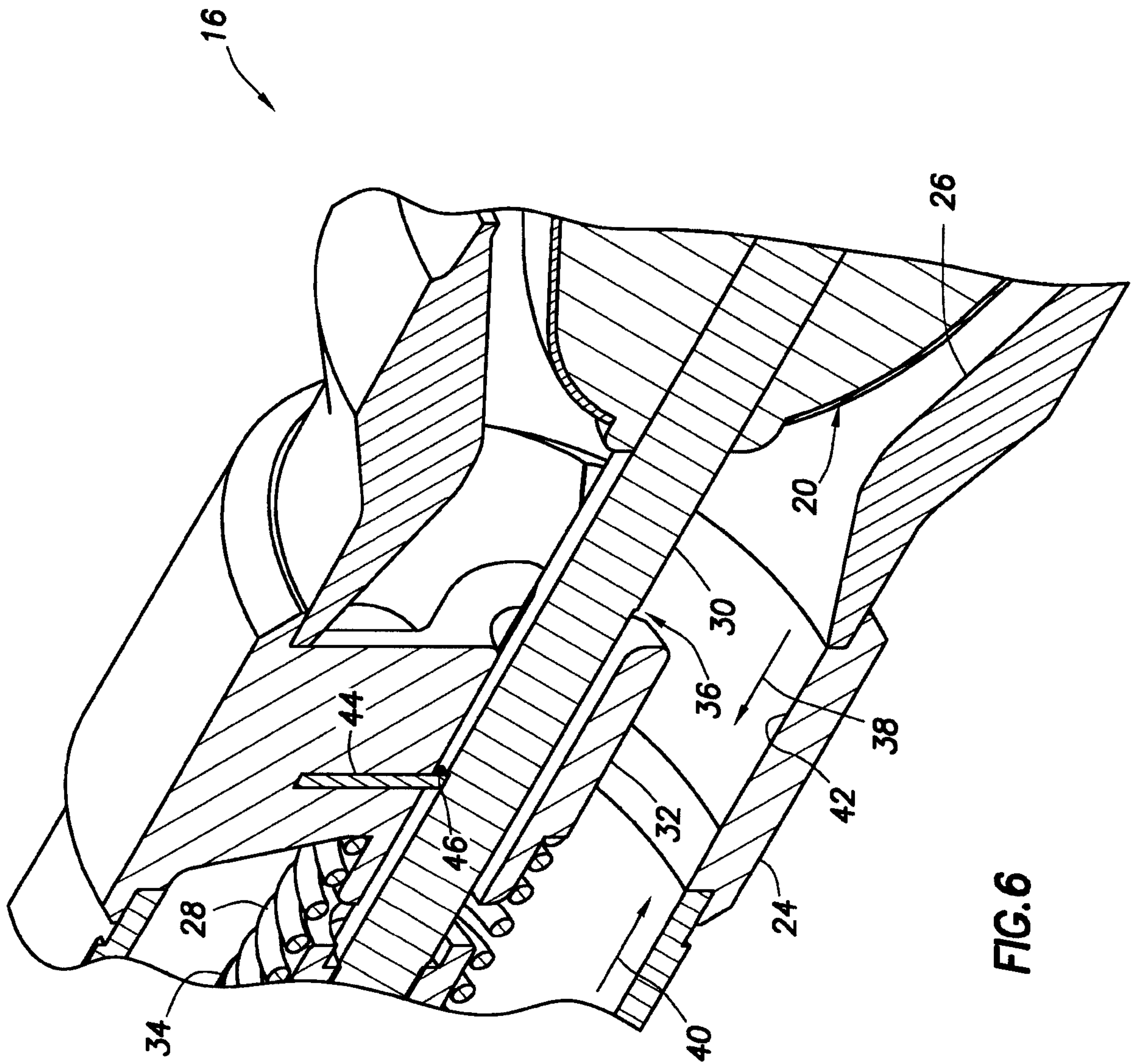

FIG. 6

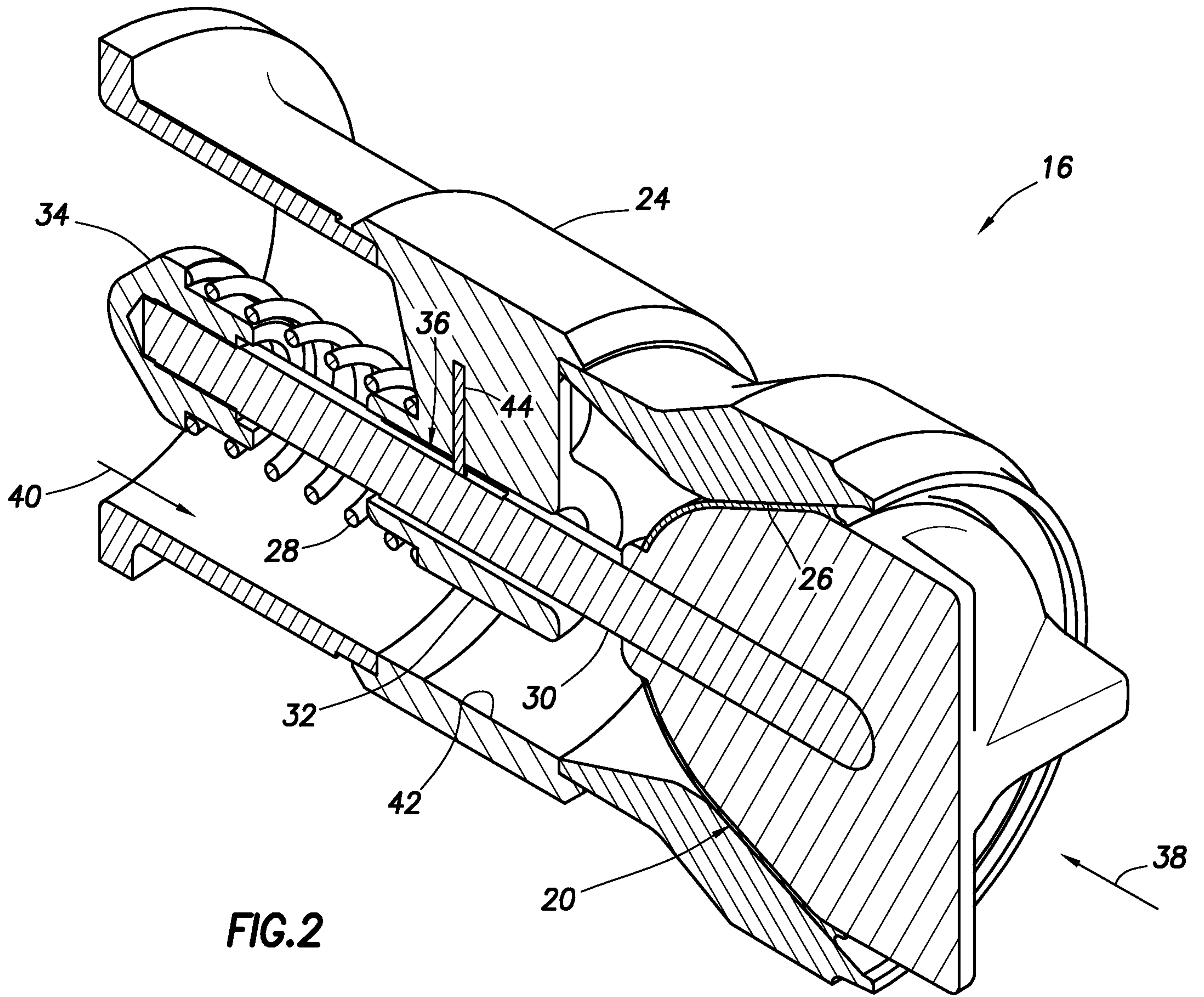

FIG.2