

F. Lamoureux,

Traveling Bag,

N^o 19,896.

Patented Sep. 12, 1865.

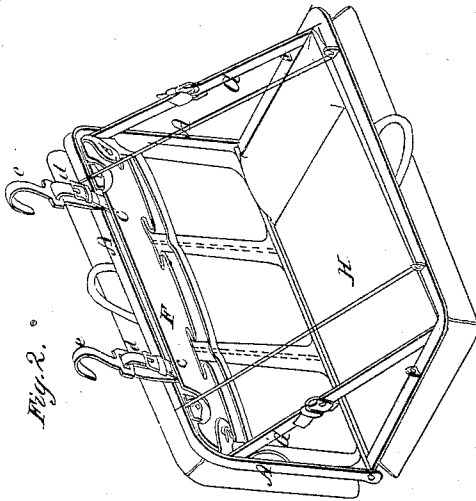

Fig. 2.

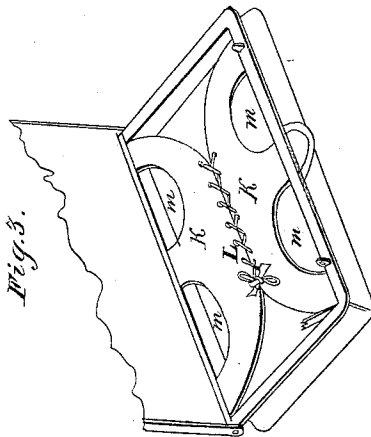

Fig. 3.

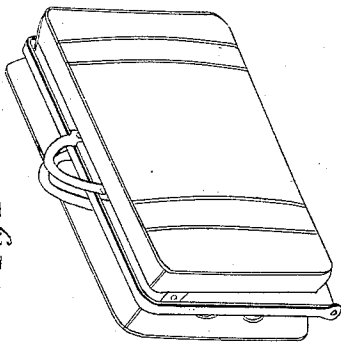

Fig. 1.

Witnesses.

John Clapp
[Signature]

Inventor.

Frederick Lamoureux

UNITED STATES PATENT OFFICE.

FREDERICK L'AMOUREUX, OF BINGHAMTON, NEW YORK.

IMPROVED TRAVELING-VALISE.

Specification forming part of Letters Patent No. **49,896**, dated September 12, 1865.

To all whom it may concern:

Be it known that I, FREDERICK L'AMOUREUX, of Binghamton, Broome county, and State of New York, have invented a new and Improved Traveling-Valise; and I do hereby declare that the following is a full and exact description thereof, reference being had to the accompanying drawings, and to the letters of reference marked thereon.

The nature of my invention consists in so constructing a traveling-valise that it can be used for the purposes of an ordinary traveling-bag, or readily converted into a bed or couch upon which a child can be placed while traveling, thus adding much to its comfort, as well as contributing to the convenience of the attendant.

To enable others skilled in the art to make and use my invention, I will proceed to describe its construction and mode of use.

I construct my valise in all respects as the ordinary bags, which are divided in two equal parts, are constructed, except that the proportions are somewhat changed as regards width and length to adapt the same to the additional use of the couch, and the frame is made sufficiently strong to avoid accident.

In making the frame A A of my valise, Figure 2, I have two loops, *c c*, made thereon, each inside of the locks; or I leave spaces at that point, around which I can pass straps *d d*, of any length desired, having buckles thereon to regulate the said length, and the straps *d d*, I pass through hooks *e e*, provided with loops, which hooks are for the purpose of hanging the valise upon the back of the car-seat, or any other place where it may be desired to hang said valise.

The hooks *e e* can be turned inside the bag and put under the lid F when not wanted for use, and thus be kept entirely out of sight. In the lid F, which keeps the two parts separated, I put two or more pockets for the convenience of the attendant, in which bottles or other necessary articles can be placed.

To the frame A A, I attach the straps G G in any convenient or proper manner, which straps prevent the valise from opening more than the required distance.

It will be readily seen that by suspending the valise by means of the hooks *e e* upon the back of a car-seat the half of the same marked H can be used for a couch for a child, or, by turning the lid F down, for a table.

In the part H, I place at convenient points loops or their equivalents, to which I can attach webbing or canvas K, Fig. 3, which may have elastic attachments; or springs may be placed under this canvas, which constitutes the bottom of the bed or couch, and which may be laced in the center, as shown at L.

Through the openings *m m m m* the air can be circulated freely, and any articles can be put that may be desired. An air bed and pillow can be used, which can be easily packed when not wanted for use and the canvas unlaced. The whole can be put entirely out of sight, and the valise resemble the bag in common use, as shown in Fig. 1.

It will be seen that with my valise a thin gauze could be attached, covering the child and entirely excluding insects, dust, &c.; and, should it be important, a few small cords or their equivalents could be attached to the frames, so as to avoid all danger to the child by falling out from any sudden motion of the vehicle or from other causes. (See red lines, Fig. 2.)

What I claim as my invention, and desire to secure by Letters Patent, is—

1. A traveling-valise so constructed that it can be readily converted into a couch or bed, for the purposes shown and described.
2. In combination with a convertible valise, the hooks or their equivalents, for the uses and purposes set forth.
3. In combination with the convertible valise and the suspending-hooks, the straps G G, for keeping the lower half in proper position.
4. The canvas bottom, constructed as shown, when used in connection with the convertible valise for the purposes described.

FREDERICK L'AMOUREUX.

Witnesses:

JOHN CLAPP,
T. R. MORGAN.