



(51) International Patent Classification:
A61M 16/06 (2006.01)

(21) International Application Number:
PCT/IB2010/053905

(22) International Filing Date:
31 August 2010 (31.08.2010)

(25) Filing Language: English

(26) Publication Language: English

(30) Priority Data:
61/254,272 23 October 2009 (23.10.2009) US

(71) Applicant (for all designated States except US): **KONINKLIJKE PHILIPS ELECTRONICS N.V.** [NL/NL]; Groenewoudseweg 1, NL-5621 BA Eindhoven (NL).

(72) Inventors; and

(75) Inventors/Applicants (for US only): **SMITH, David, W.** [US/US]; P.O. Box 3001 345 Scarborough Road, Briarcliff Manor, New York 10510-8001 (US). **JABLONSKI, Gregory, John** [US/US]; P.O. Box 3001 345 Scarborough Road, Briarcliff Manor, New York 10510-8001 (US). **ANDREWS, Derrick, Blake** [US/US]; P.O. Box 3001 345 Scarborough Road, Briarcliff Manor, New York 10510-8001 (US). **LOCKHART, Harold, Allen** [US/US]; P.O. Box 3001 345 Scarborough Road, Briarcliff Manor, New York 10510-8001 (US).

(74) Agent: **DAMEN, Daniel, M.**; Philips Intellectual Property & Standards, High Tech Campus 44, P.O. Box 220, NL-5600 AE Eindhoven (NL).

(81) Designated States (unless otherwise indicated, for every kind of national protection available): AE, AG, AL, AM, AO, AT, AU, AZ, BA, BB, BG, BH, BR, BW, BY, BZ, CA, CH, CL, CN, CO, CR, CU, CZ, DE, DK, DM, DO, DZ, EC, EE, EG, ES, FI, GB, GD, GE, GH, GM, GT, HN, HR, HU, ID, IL, IN, IS, JP, KE, KG, KM, KN, KP, KR, KZ, LA, LC, LK, LR, LS, LT, LU, LY, MA, MD, ME, MG, MK, MN, MW, MX, MY, MZ, NA, NG, NI, NO, NZ, OM, PE, PG, PH, PL, PT, RO, RS, RU, SC, SD, SE, SG, SK, SL, SM, ST, SV, SY, TH, TJ, TM, TN, TR, TT, TZ, UA, UG, US, UZ, VC, VN, ZA, ZM, ZW.

(84) Designated States (unless otherwise indicated, for every kind of regional protection available): ARIPO (BW, GH, GM, KE, LR, LS, MW, MZ, NA, SD, SL, SZ, TZ, UG, ZM, ZW), Eurasian (AM, AZ, BY, KG, KZ, MD, RU, TJ, TM), European (AL, AT, BE, BG, CH, CY, CZ, DE, DK, EE, ES, FI, FR, GB, GR, HR, HU, IE, IS, IT, LT, LU, LV, MC, MK, MT, NL, NO, PL, PT, RO, SE, SI, SK, SM, TR), OAPI (BF, BJ, CF, CG, CI, CM, GA, GN, GQ, GW, ML, MR, NE, SN, TD, TG).

Declarations under Rule 4.17:

— as to applicant's entitlement to apply for and be granted a patent (Rule 4.17(ii))

[Continued on next page]

(54) Title: PATIENT INTERFACE DEVICE WITH ADJUSTABLE HEADGEAR AND FRAME

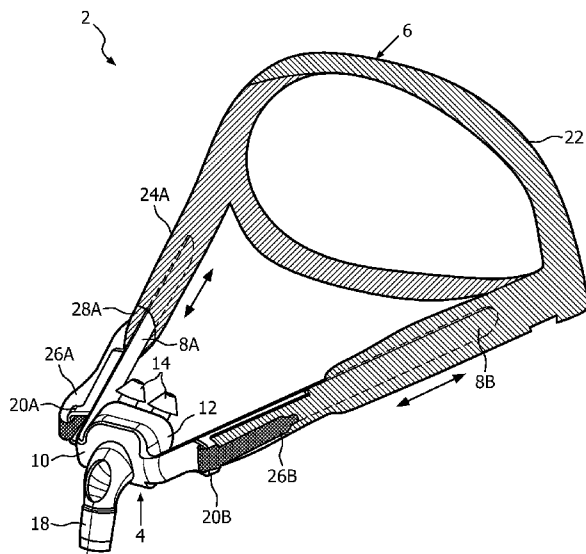

FIG. 1

(57) Abstract: A patient interface device (2) includes a main frame (4) and a headgear (6). The main frame includes a central support portion (10) for supporting a cushion component (12) and first and second arms (8A, 8B) extending from the central support portion. The headgear includes a support portion (21), and first and second straps (24A, 24B) extending therefrom. The first strap has a first pocket (28A) and the second strap has a second pocket (28B), wherein the first arm is received and moveable within the first pocket along a longitudinal axis of the first strap and the second arm is received and moveable within the second pocket along a longitudinal axis of the second strap. The headgear also includes first and second fastening mechanisms (20A, 20B, 26A, 26B) for securing the headgear to the main frame, holding the first arm in a selected position within the first pocket and holding the second arm in a selected position within the second pocket.



- *as to the applicant's entitlement to claim the priority of the earlier application (Rule 4.17(iii))*
- Published:**
- *with international search report (Art. 21(3))*

PATIENT INTERFACE DEVICE WITH ADJUSTABLE HEADGEAR AND FRAME

This patent application claims the priority benefit under 35 U.S.C. § 119(e) of U.S. Provisional Application No. 61/254,272 filed on October 23, 2009, the contents of which are herein incorporated by reference.

The present invention relates to patient interface devices, and, in particular, to a patient interface device having an adjustable, integrated headgear and frame for allowing the fit of the patient interface device to be selectively adjusted.

There are numerous situations where it is necessary or desirable to deliver a flow of breathing gas non-invasively to the airway of a patient, i.e., without intubating the patient or surgically inserting a tracheal tube in their esophagus. For example, it is known to ventilate a patient using a technique known as non-invasive ventilation. It is also known to deliver continuous positive airway pressure (CPAP) or variable airway pressure, which varies with the patient's respiratory cycle, to treat a medical disorder, such as sleep apnea syndrome, in particular, obstructive sleep apnea (OSA), or congestive heart failure.

Non-invasive ventilation and pressure support therapies involve the placement of a patient interface device including a cushion component on the face of a patient. The cushion component may be, without limitation, a nasal mask that covers the patient's nose, a nasal cushion having nasal prongs that are received within the patient's nares, a nasal/oral mask that covers the nose and mouth, or full face mask that covers the patient's face. The patient interface device interfaces the ventilator or pressure support device with the airway of the patient, so that a flow of breathing gas can be delivered from the pressure/flow generating device to the airway of the patient. It is known to maintain such devices on the face of a wearer by a headgear having one or more straps adapted to fit over/around the patient's head. Because such patient interface devices are typically worn for an extended period of time, it is important for the headgear to maintain the cushion component of the device in a tight enough seal against the patient's face without discomfort.

For patient interface devices, a key engineering challenge is to balance patient comfort against stability of the device as well as minimize unintentional gas

leakage at the patient-cushion interface. As a patient changes sleeping positions through the course of the night, the mask portions of patient interface devices may become dislodged, and the seal against the patient's may be broken. A dislodged mask portion can be stabilized by the increasing strapping force provided by the headgear, but increased strapping force tends to reduce patient comfort. This design conflict is further complicated by the widely varying facial geometries that a given patient interface device design needs to accommodate. Such wide variation in facial geometry is demonstrated in Table 1 below (source: PeopleSize2008 database, OpenErgonomics Ltd.).

	5% US population	95% US population	
	Min (mm)	Max (mm)	Variation (mm)
Nose Tip Depth	15	23	8
Nose Length	44	57	13
Eye corner to back of head	151	184	33
Nose base to back of head	182	216	34
Cheekbone width	126	150	24
Head Breadth	140	167	27

TABLE 1

[06] To further complicate this issue, individual tolerances for comfort also vary widely. For instance, given the same level of mechanical pressure on a specific area of the face, one person may develop significant marks, blisters, or open sores, while another person may feel no effects at all.

[07] One known patient interface device is the Swift LT available from ResMed Inc. In that device, a plastic stiffener is fixedly stitched to the fabric headgear extensions. This allows for stability of the mask, but does not allow for relative motion between the fabric and the stiffener. Therefore, a patient cannot properly adjust this to their specific needs.

- [08] Another known patient interface device is the ComfortGel nasal mask available from Philips Respironics. That device includes four attachment points between the fabric headgear and the plastic mask that allow for relative motion between the fabric headgear and the plastic mask. However, in this device, the mask is free to move in many degrees of freedom, which can lead to instability (especially for a pillows style masks).
- [09] In one embodiment, a patient interface device is provided that includes a main frame having a central support portion for supporting a cushion component and a first arm and a second arm extending from the central support portion, and a headgear. The headgear includes a support portion, a first strap extending from a first side of the support portion and a second strap extending from a second side of the support portion. The first strap has a first pocket and the second strap has a second pocket, wherein the first arm is received and moveable within the first pocket along a longitudinal axis of the first strap and the second arm is received and moveable within the second pocket along a longitudinal axis of the second strap. Also, the headgear includes a first fastening mechanism for securing the headgear to the main frame and holding the first arm in a selected position within the first pocket and a second fastening mechanism for securing the headgear to the main frame and holding the second arm in a selected position within the second pocket.
- [10] The first fastening mechanism may include a first strap loop provided on the first arm that receives an end of the first strap therethrough, and the second fastening mechanism may include a second strap loop provided on the second arm that receives an end of the second strap therethrough. The first fastening mechanism may further include a first hook and loop fastener system provided on the first strap for securing the end of the first strap to an exterior of the first strap after the first strap is inserted through the first strap loop, and the second fastening mechanism may further include a second hook and loop fastener system provided on the second strap for securing the end of the second strap to an exterior of the second strap after the first strap is inserted through the second strap loop.

- [11] In an exemplary embodiment, the headgear is made of a soft, flexible material, such as fabric, and the main frame is made of a stiff material, such as a thermoplastic material.
- [12] A method of fitting a patient interface device is also provided. The method includes receiving the patient interface device, wherein the patient interface device includes: (i) a main frame, the main frame having a central support portion for supporting a cushion component and a first arm and a second arm extending from the central support portion; and (ii) a headgear, the headgear including a support portion, a first strap extending from a first side of the support portion and a second strap extending from a second side of the support portion, the first strap having a first pocket and the second strap having a second pocket, inserting the first arm into the first pocket, inserting the second arm into the second pocket, moving the first arm within the first pocket along a longitudinal axis of the first strap to a first selected position within the first pocket and securing the headgear to the main frame and securing the first arm in the first selected position, and moving the second arm within the second pocket along a longitudinal axis of the second strap to a second selected position within the second pocket and securing the headgear to the main frame and securing the second arm in the second selected position.
- [13] These and other objects, features, and characteristics of the present invention, as well as the methods of operation and functions of the related elements of structure and the combination of parts and economies of manufacture, will become more apparent upon consideration of the following description and the appended claims with reference to the accompanying drawings, all of which form a part of this specification, wherein like reference numerals designate corresponding parts in the various figures. It is to be expressly understood, however, that the drawings are for the purpose of illustration and description only and are not intended as a definition of the limits of the invention. As used in the specification and in the claims, the singular form of “a”, “an”, and “the” include plural referents unless the context clearly dictates otherwise.
- [14] FIG. 1 is an isometric view of a patient interface device according to one particular embodiment of the present invention;

- [15] FIG. 2 is an isometric view of the main frame of the patient interface device of FIG. 1; and
- [16] FIG. 3 is an isometric view of the headgear of the patient interface device of FIG. 1.
- [17] Directional phrases used herein, such as, for example and without limitation, top, bottom, left, right, upper, lower, front, back, and derivatives thereof, relate to the orientation of the elements shown in the drawings and are not limiting upon the claims unless expressly recited therein. As employed, herein, the statement that two or more parts or components are “coupled” together shall mean that the parts are joined or operate together either directly or through one or more intermediate parts or components. As employed herein, the statement that two or more parts or components “engage” one another shall mean that the parts exert a force against one another either directly or through one or more intermediate parts or components. As employed herein, the term “number” shall mean one or an integer greater than one (i.e., a plurality).
- [18] FIG. 1 is an isometric view of a patient interface device 2 according to one particular embodiment of the present invention. Patient interface device 2 includes a main frame 4 and headgear 6. Main frame 4 is preferably made of a stiff material such as a thermoplastic, and headgear is preferably made of a soft, flexible material such as a fabric material. As described in greater detail herein, main frame 4 is coupled to headgear 6 in a manner that allows main frame 4 to be selectively moved relative to headgear 6 in order to adjust the fit of patient interface device 2.
- [19] FIG. 2 is an isometric view of main frame 4. Main frame 4 includes arms 8A and 8B and a cushion support portion 10. Arms 8A and 8B extend outwardly from cushion support portion 10 of main frame 4 and serve as stiffening elements for patient interface device 2. Cushion support portion 10 receives and holds a nasal cushion 12 having nasal prongs 14. It is to be understood that nasal cushion 12 having nasal prongs 14 is but one example of a cushion component that may be used with main frame 4, and that other cushion components, such as, without limitation, a nasal/oral mask, may also be used. Cushion support portion 10 includes an opening 16 to which there is attached a fluid coupling device 18, such as a swivel conduit as shown, for carrying fluid, such as a

breathing gas, to nasal cushion 12 from an external gas source (not shown), such as a blower or other suitable device. It is to be understood that the present invention contemplates a variety of different fluid coupling devices 18 that could be attached, either permanently or selectively, to opening 16 to carry fluid to or from nasal cushion 10.

[20] Arm 8A of main frame 4 includes a strap loop 20A and arm 8B of main frame 4 includes a strap loop 20B. Strap loops 20A and 20B are structured to cooperate with headgear 6 as described below.

[21] Referring to FIG. 3, headgear 6 includes a rear support portion 22 that is structured to engage the back of the patient's head. Headgear 6 also includes strap 24A and strap 24B extending from rear support portion 22. Strap 24A includes an end portion 26A and has a pocket 28A formed therein, with the entrance to pocket 28A being on the inner side of strap 24A as seen in FIG. 3. Similarly, strap 24B includes an end portion 26B and has a pocket 28B formed therein, with the entrance to pocket 28B being on the inner side of strap 24B as seen in FIG. 3.

[22] When patient interface device 2 is assembled, arm 8A of main frame 4 is inserted into pocket 28A and arm 8B of main frame 4 inserted into pocket 28B as seen in FIG. 1. Arms 8A and 8B are able to move freely within pockets 28A, 28B along the respective longitudinal axes of straps 24A and 24B as shown by the arrows in FIG. 1. As will be appreciated, the position of arms 8A and 8B within pockets 28A, 28B will determine the size of patient interface device 2.

[23] A fastening system is provided for securing main frame 4 to headgear 6 once the desired position of arms 8A and 8B within pockets 28A, 28B is determined and achieved. In the illustrated embodiment, fastening system 18 is a hook and loop fastener, such as VELCRO®. In particular, the exterior of each of strap 24A and 24B includes a loop fastener portion, and a corresponding hook fastener portion is provided on the exterior of each of end portions 26A, 26B. Thus, strap 24A may be threaded through strap loop 20A and then bent back on itself to adhere the hook fastener portion of end portion 26A of strap 24A to the loop fastener portion provided on the exterior of strap 24A. Similarly, strap 24B may be threaded through strap loop 20B and then bent back on itself to adhere the hook fastener portion of end portion 26B of strap 24B to the loop

fastener portion provided on the exterior of strap 24B. Of course, the present invention contemplates that the fastening system may use other forms of connection other than hook and loop fasteners such as snaps or buckles.

[24] Thus, in the embodiment just described, the tension of straps 24A and 24B may be adjusted for a specific facial anatomy and comfort level. As the tension of straps 24A and 24B is adjusted, straps 24A, 24B move through strap loops 20A, 20B. This action will tend to pull main frame 4 further into the pockets 28A and 28B when applying tension, and allow main frame 4 to extend from pockets 28A and 28B when tension is released. In either case, main frame 4, through arms 8A and 8B, is always providing support around the patient's head, and the soft cushioning sections of headgear 6 are always in contact with the patient's skin. The present invention is thus advantageous as it allows for both stability and adjustability by allowing arms 8A and 8B to slide longitudinally/axially within pockets 28A and 28B while at the same time restricting movement of arms 8A and 8B in other directions.

[25] Furthermore, ease of use is another advantage of present invention. By providing the fastening system by way of cooperation between end portions 26A and 26B and strap loops 18A and 18B, the primary means of adjustment is near the cheeks of the patient. This is a natural position for a primary adjustment and does not require complex hand motions or ranges of motion from the patient.

[26] In short, in the present invention, the position of main frame 4 relative to headgear 6 may be selectively altered and secured as just described in order to allow the size of patient interface device 2 to be selectively adjusted by the patient or a caregiver to optimize the comfort and stability of patient interface device 2 for the patient's particular facial anatomy. This adjustment mechanism is particularly advantageous as it allows for a broad range of motion for the main dimension of patient interface device 2 to be adjusted by the patient. In addition, as noted elsewhere herein, arms 8A and 8B of main frame 4, which are not permanently affixed to headgear 6, extend far along the side of the patient's head when patient interface device 2 is worn and act as stiffening elements which also assist in optimizing the comfort and stability of patient interface device 2.

[27] Although the invention has been described in detail for the purpose of illustration based on what is currently considered to be the most practical and preferred embodiments, it is to be understood that such detail is solely for that purpose and that the invention is not limited to the disclosed embodiments, but, on the contrary, is intended to cover modifications and equivalent arrangements that are within the spirit and scope of the appended claims. For example, it is to be understood that the present invention contemplates that, to the extent possible, one or more features of any embodiment can be combined with one or more features of any other embodiment.

What is Claimed is:

1. A patient interface device (2), comprising:
a main frame (4) comprising a central support portion (10) for supporting a cushion component, a first arm (8A) extending from the central support portion, and a second arm (8B) extending from the central support portion; and
a headgear (6) including a support portion (22), a first strap (24A) extending from a first side of the support portion, and a second strap (24B) extending from a second side of the support portion, the first strap having a first pocket (28A) and the second strap having a second pocket (28B), wherein the first arm is received and moveable within the first pocket along a longitudinal axis of the first strap and the second arm is received and moveable within the second pocket along a longitudinal axis of the second strap, the headgear including a first fastening mechanism for securing the headgear to the main frame and holding the first arm in a selected position within the first pocket and a second fastening mechanism for securing the headgear to the main frame and holding the second arm in a selected position within the second pocket.

2. The patient interface device of claim 1, wherein the first fastening mechanism includes a first strap loop provided on the first arm, the first strap loop receiving an end of the first strap therethrough, wherein the second fastening mechanism includes a second strap loop provided on the second arm, the second strap loop receiving an end of the second strap therethrough.

3. The patient interface device of claim 2, the first fastening mechanism further including a first hook and loop fastener system provided on the first strap for securing the end of the first strap to an exterior of the first strap after the first strap is inserted through the first strap loop, and the second fastening mechanism further including a second hook and loop fastener system provided on the second strap for securing the end of the second strap to an exterior of the second strap after the first strap is inserted through the second strap loop.

4. The patient interface device of claim 1, wherein the headgear is made of a soft, flexible material and the main frame is made of a stiff material.

5. The patient interface device of claim 4, wherein the headgear is made of a fabric material.

6. The patient interface device of claim 4, wherein the main frame is made of a thermoplastic material.

7. A method of fitting a patient interface device (2), comprising:
providing a patient interface device comprising: (i) a main frame (4) comprising a central support portion (10) for supporting a cushion component, a first arm (8A) extending from the central support portion, and a second arm (8B) extending from the central support portion, and (ii) a headgear (6), the headgear including a support portion (22), a first strap (24A) extending from a first side of the support portion and a second strap (24B) extending from a second side of the support portion, the first strap having a first pocket (28A) and the second strap having a second pocket (28B);

inserting the first arm into the first pocket;

inserting the second arm into the second pocket;

moving the first arm within the first pocket along a longitudinal axis of the first strap to a first selected position within the first pocket and securing the headgear to the main frame and securing the first arm in the first selected position; and

moving the second arm within the second pocket along a longitudinal axis of the second strap to a second selected position within the second pocket and securing the headgear to the main frame and securing the second arm in the second selected position.

8. The method according to claim 7, wherein the securing the first arm in the first selected position comprises inserting a first end of the first strap through a first

strap loop provided on the first arm, and wherein the securing the second arm in the second selected position comprises inserting a second end of the second strap through a second strap loop provided on the second arm.

9. The method according to claim 8, wherein the securing the first arm in the first selected position further comprises securing the first arm in the first selected position with a first hook and loop fastener system, and wherein the securing the second arm in the second selected position further comprises securing the second arm in the second selected position with a second hook and loop fastener system.

10. The method according to claim 7, wherein the moving and securing steps are performed after the patient interface device is donned by a patient.

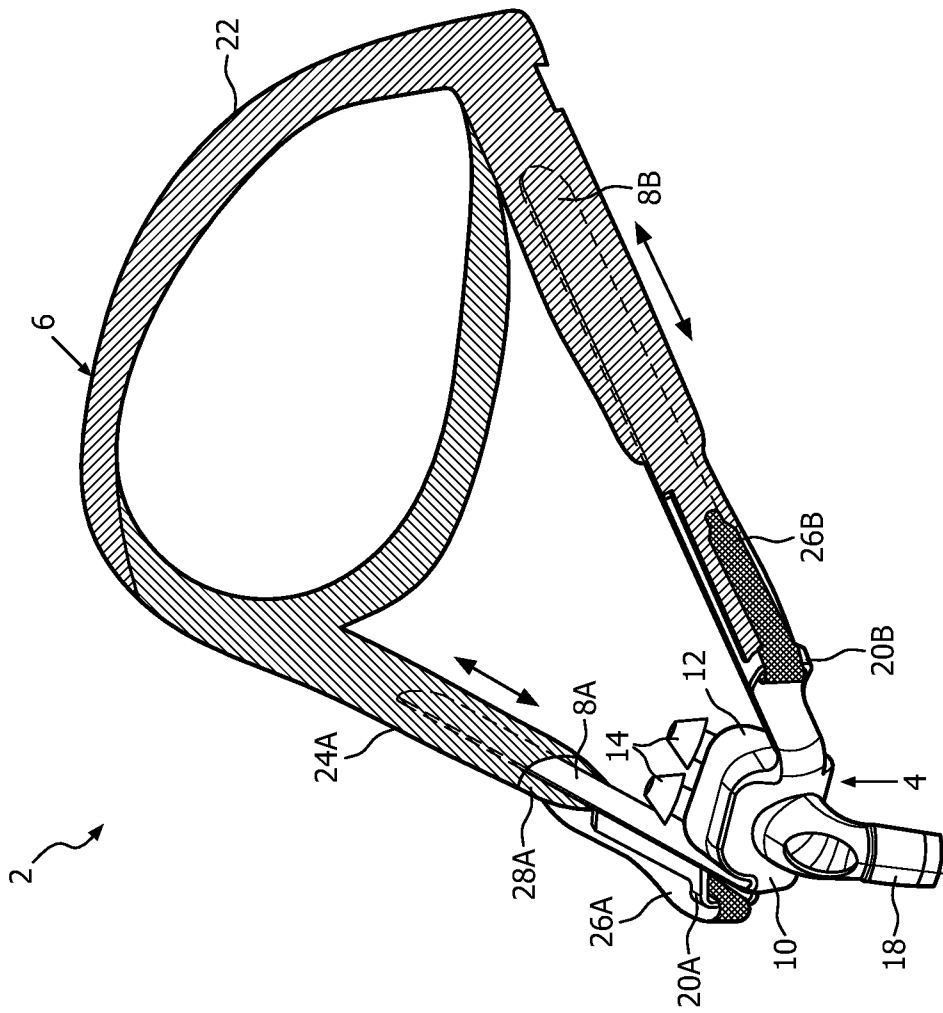

FIG. 1

2/3

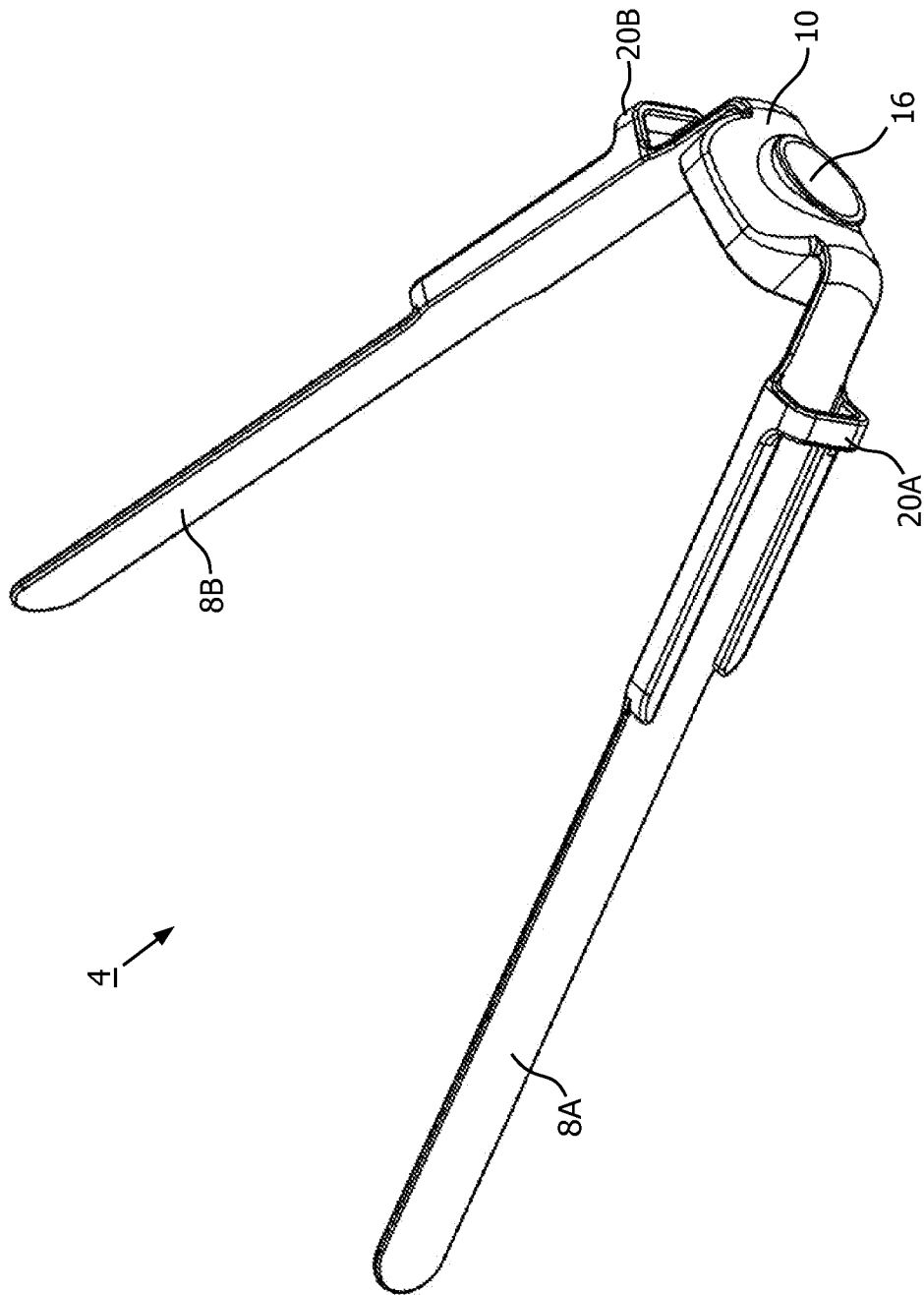

FIG. 2

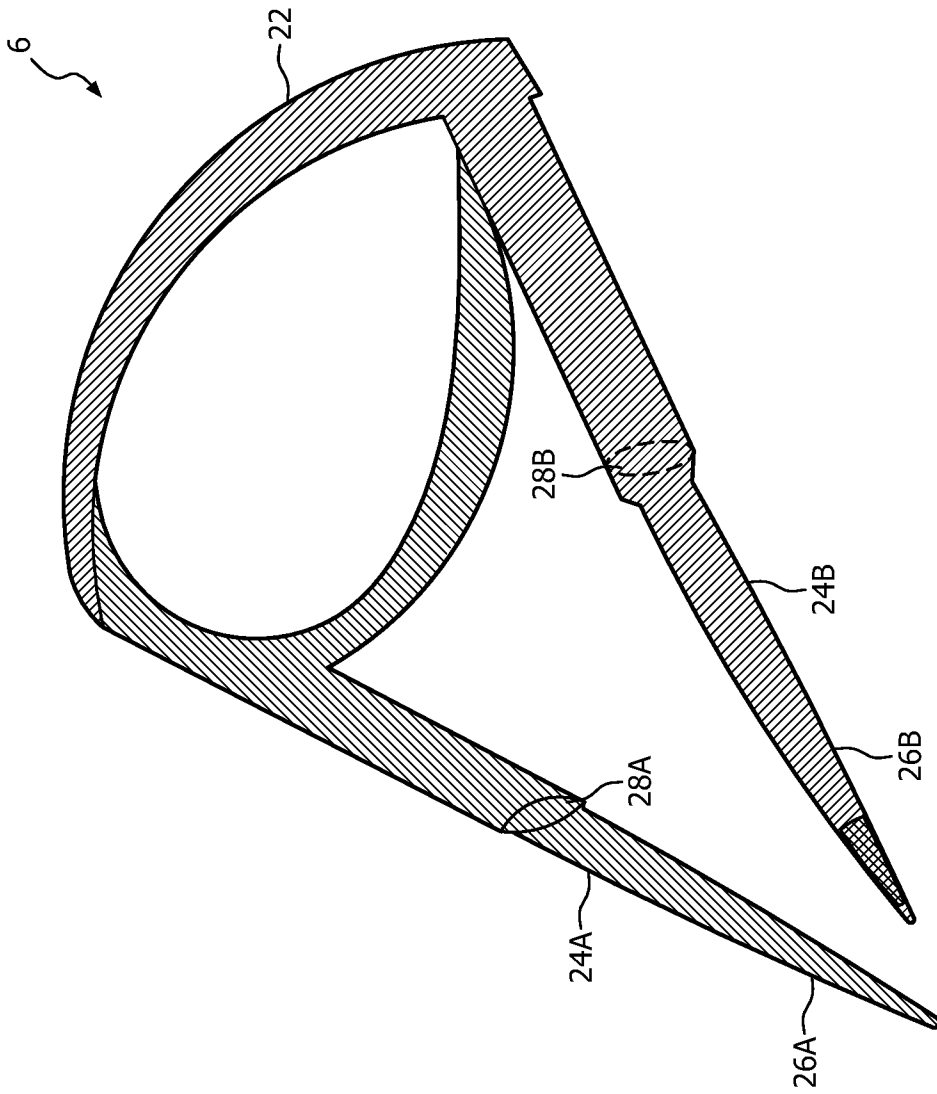

FIG. 3

INTERNATIONAL SEARCH REPORT

International application No
PCT/IB2010/053905

A. CLASSIFICATION OF SUBJECT MATTER INV. A61M16/06 ADD.				
According to International Patent Classification (IPC) or to both national classification and IPC				
B. FIELDS SEARCHED				
Minimum documentation searched (classification system followed by classification symbols) A61M				
Documentation searched other than minimum documentation to the extent that such documents are included in the fields searched				
Electronic data base consulted during the international search (name of data base and, where practical, search terms used) EPO-Internal				
C. DOCUMENTS CONSIDERED TO BE RELEVANT				
Category*	Citation of document, with indication, where appropriate, of the relevant passages	Relevant to claim No.		
X	US 2004/226566 A1 (GUNARATNAM MICHAEL K [AU] ET AL) 18 November 2004 (2004-11-18) paragraphs [0259] - [0264], [0282] - [0285]; figures 38-45,52,53	1-10		
X	EP 2 022 528 A2 (RESMED LTD [AU]) 11 February 2009 (2009-02-11) paragraph [0689]; figures 12-26-1,12-26-2	1,4-7,10		
A	US 2006/196511 A1 (LAU GREG Y [US] ET AL) 7 September 2006 (2006-09-07) the whole document	1,7		
----- -/--				
<input checked="" type="checkbox"/> Further documents are listed in the continuation of Box C.				
<input checked="" type="checkbox"/> See patent family annex.				
* Special categories of cited documents :				
<table style="width: 100%; border: none;"> <tr> <td style="width: 50%; border: none; vertical-align: top;"> "A" document defining the general state of the art which is not considered to be of particular relevance "E" earlier document but published on or after the international filing date "L" document which may throw doubts on priority claim(s) or which is cited to establish the publication date of another citation or other special reason (as specified) "O" document referring to an oral disclosure, use, exhibition or other means "P" document published prior to the international filing date but later than the priority date claimed </td> <td style="width: 50%; border: none; vertical-align: top;"> "T" later document published after the international filing date or priority date and not in conflict with the application but cited to understand the principle or theory underlying the invention "X" document of particular relevance; the claimed invention cannot be considered novel or cannot be considered to involve an inventive step when the document is taken alone "Y" document of particular relevance; the claimed invention cannot be considered to involve an inventive step when the document is combined with one or more other such documents, such combination being obvious to a person skilled in the art. "&" document member of the same patent family </td> </tr> </table>			"A" document defining the general state of the art which is not considered to be of particular relevance "E" earlier document but published on or after the international filing date "L" document which may throw doubts on priority claim(s) or which is cited to establish the publication date of another citation or other special reason (as specified) "O" document referring to an oral disclosure, use, exhibition or other means "P" document published prior to the international filing date but later than the priority date claimed	"T" later document published after the international filing date or priority date and not in conflict with the application but cited to understand the principle or theory underlying the invention "X" document of particular relevance; the claimed invention cannot be considered novel or cannot be considered to involve an inventive step when the document is taken alone "Y" document of particular relevance; the claimed invention cannot be considered to involve an inventive step when the document is combined with one or more other such documents, such combination being obvious to a person skilled in the art. "&" document member of the same patent family
"A" document defining the general state of the art which is not considered to be of particular relevance "E" earlier document but published on or after the international filing date "L" document which may throw doubts on priority claim(s) or which is cited to establish the publication date of another citation or other special reason (as specified) "O" document referring to an oral disclosure, use, exhibition or other means "P" document published prior to the international filing date but later than the priority date claimed	"T" later document published after the international filing date or priority date and not in conflict with the application but cited to understand the principle or theory underlying the invention "X" document of particular relevance; the claimed invention cannot be considered novel or cannot be considered to involve an inventive step when the document is taken alone "Y" document of particular relevance; the claimed invention cannot be considered to involve an inventive step when the document is combined with one or more other such documents, such combination being obvious to a person skilled in the art. "&" document member of the same patent family			
Date of the actual completion of the international search	Date of mailing of the international search report			
18 November 2010	03/12/2010			
Name and mailing address of the ISA/ European Patent Office, P.B. 5818 Patentlaan 2 NL - 2280 HV Rijswijk Tel. (+31-70) 340-2040, Fax: (+31-70) 340-3016	Authorized officer <p style="text-align: center; font-weight: bold;">Borowski, Aleksander</p>			

INTERNATIONAL SEARCH REPORT

International application No
PCT/IB2010/053905

C(Continuation). DOCUMENTS CONSIDERED TO BE RELEVANT		
Category*	Citation of document, with indication, where appropriate, of the relevant passages	Relevant to claim No.
A	<p>WO 2008/007985 A1 (FISHER & PAYKEL HEALTHCARE LTD [NZ]; MCAULEY ALASTAIR EDWIN [NZ]; ERST) 17 January 2008 (2008-01-17) page 9, line 24 - page 10, line 17; figures 9-16</p> <p style="text-align: center;">-----</p>	1,7
A	<p>WO 2009/059353 A1 (RESMED LTD [AU]; DOHERTY RENEE FRANCES [AU]; BRAMBILLA ENRICO [AU]; GI) 14 May 2009 (2009-05-14) the whole document</p> <p style="text-align: center;">-----</p>	1,7

INTERNATIONAL SEARCH REPORT

Information on patent family members

International application No PCT/IB2010/053905

Patent document cited in search report	A1	Publication date	Patent family member(s)	Publication date
US 2004226566	A1	18-11-2004	US 2009095298 A1	16-04-2009
			US 2007062539 A1	22-03-2007
			US 2008092904 A1	24-04-2008
			US 2008092905 A1	24-04-2008
			US 2008092906 A1	24-04-2008
			US 2008099027 A1	01-05-2008
			US 2008105264 A1	08-05-2008
			US 2008099024 A1	01-05-2008
<hr style="border-top: 1px dashed black;"/>				
EP 2022528	A2	11-02-2009	AU 2008203372 A1	19-02-2009
			JP 2009039528 A	26-02-2009
			NZ 570059 A	27-08-2010
			US 2009044808 A1	19-02-2009
<hr style="border-top: 1px dashed black;"/>				
US 2006196511	A1	07-09-2006	NONE	
<hr style="border-top: 1px dashed black;"/>				
WO 2008007985	A1	17-01-2008	AU 2007273324 A1	17-01-2008
			AU 2008101251 A4	05-02-2009
			AU 2008101252 A4	05-02-2009
			AU 2008101254 A4	05-02-2009
			AU 2008101256 A4	05-02-2009
			AU 2008101257 A4	05-02-2009
			AU 2008101258 A4	05-02-2009
			AU 2009100074 A4	26-02-2009
			CA 2655839 A1	17-01-2008
			EP 2051762 A1	29-04-2009
			US 2010000537 A1	07-01-2010
			US 2009241961 A1	01-10-2009
			US 2010083961 A1	08-04-2010
<hr style="border-top: 1px dashed black;"/>				
WO 2009059353	A1	14-05-2009	US 2010258136 A1	14-10-2010
<hr style="border-top: 1px dashed black;"/>				