

(12) INTERNATIONAL APPLICATION PUBLISHED UNDER THE PATENT COOPERATION TREATY (PCT)

(19) World Intellectual Property Organization  
International Bureau



(43) International Publication Date  
5 June 2003 (05.06.2003)

PCT

(10) International Publication Number  
WO 03/045683 A1

- (51) International Patent Classification<sup>7</sup>: B32B 3/02, 33/00, 27/04, 27/12 (74) Agent: MYERS, BIGEL, SIBLEY & SAJOVEC; P.O. Box 37428, Raleigh, NC 27627 (US).
- (21) International Application Number: PCT/US02/35819 (81) Designated States (national): AE, AG, AL, AM, AT, AU, AZ, BA, BB, BG, BR, BY, BZ, CA, CH, CN, CO, CR, CU, CZ, DE, DK, DM, DZ, EC, EE, ES, FI, GB, GD, GE, GH, GM, HR, HU, ID, IL, IN, IS, JP, KE, KG, KP, KR, KZ, LC, LK, LR, LS, LT, LU, LV, MA, MD, MG, MK, MN, MW, MX, MZ, NO, NZ, OM, PH, PL, PT, RO, RU, SD, SE, SG, SI, SK, SL, TJ, TM, TN, TR, TT, TZ, UA, UG, US, UZ, VC, VN, YU, ZA, ZM, ZW.
- (22) International Filing Date: 7 November 2002 (07.11.2002)
- (25) Filing Language: English
- (26) Publication Language: English
- (30) Priority Data: 09/990,115 21 November 2001 (21.11.2001) US
- (71) Applicant (for all designated States except US): COLLINS & AIKMAN PRODUCTS CO. [US/US]; 250 Stephenson Highway, Troy, MI 48083 (US).
- (84) Designated States (regional): ARIPO patent (GH, GM, KE, LS, MW, MZ, SD, SL, SZ, TZ, UG, ZM, ZW), Eurasian patent (AM, AZ, BY, KG, KZ, MD, RU, TJ, TM), European patent (AT, BE, BG, CH, CY, CZ, DE, DK, EE, ES, FI, FR, GB, GR, IE, IT, LU, MC, NL, PT, SE, SK, TR), OAPI patent (BF, BJ, CF, CG, CI, CM, GA, GN, GQ, GW, ML, MR, NE, SN, TD, TG).

- (72) Inventors; and  
(75) Inventors/Applicants (for US only): GEBRESELISSIE, Girma [US/US]; 21180 Potomac, Southfield, MI 48076 (US). KHAMBETE, Surendra [IN/US]; 2482 Wickfield, West Bloomfield, MI 48323 (US). MESSINA, Anthony [US/US]; 3303 Ellwood, Royal Oak, MI 48073 (US).

Published:  
— with international search report

For two-letter codes and other abbreviations, refer to the "Guidance Notes on Codes and Abbreviations" appearing at the beginning of each regular issue of the PCT Gazette.

(54) Title: SOUND ATTENUATING/ABSORBING LAMINATES AND METHODS OF MAKING SAME

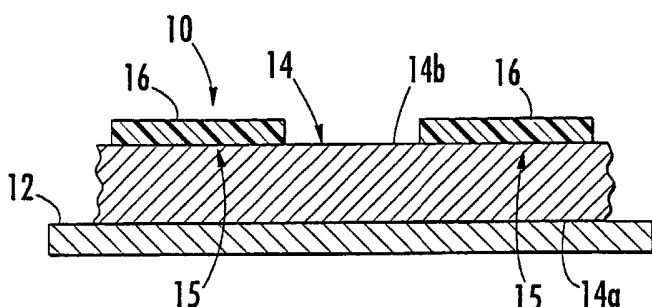

(57) Abstract: Sound attenuating laminates (40,140,240,340) for use within vehicles are provided that include a substrate (44) and polyurethane (16) attached to selected portions of the substrate (15). The polyurethane is non-porous and serves as a barrier to attenuate sound passing through the substrate. Additional non-porous polyurethane may be added to one or more selected portions of the polyurethane layer to enhance sound attenuation characteristics in the one or more selected portions. The polyurethane serves as an absorber of sound.



WO 03/045683 A1

## SOUND ATTENUATING/ABSORBING LAMINATES AND METHODS OF MAKING SAME

### FIELD OF THE INVENTION

The present invention relates generally to vehicles and, more particularly, to trim components utilized within vehicles.

5

### BACKGROUND OF THE INVENTION

It is generally considered desirable to reduce the level of noise within a vehicle passenger compartment. External noises, such as road noise, engine noise, vibrations, etc., as well as noises emanating from within passenger compartments, may be attenuated through the use of various acoustical materials. Accordingly, sound attenuating materials for vehicles, such as automobiles, are conventionally used in the dashboard, in conjunction with carpeting for floor panels, in the wheel wells, in the trunk compartment, under the hood, and as part of the headliner.

10

15

The attenuation of external noise is conventionally referred to as sound transmission loss (STL). The attenuation of internal noise is conventionally referred to as sound absorption. The acoustic impedance of a material is defined as material density times acoustic velocity, and is expressed in units of Rayls (Newton-seconds/meter<sup>3</sup>). Acoustic impedance defines how easy it is for air to move through a material. Thus, for fibrous materials, acoustic impedance

20

25

depends upon the density of the fibrous material and fiber diameter. Generally, the heavier the blanket and the finer the fibers, the higher the acoustic impedance. Moreover, thicker layers typically have more acoustic impedance than thin layers. The ability of a material to attenuate noise is conventionally defined by the material's STL, acoustic impedance, and absorption characteristics.

Carpeting used to cover the floor areas of vehicles, such as automobiles, is conventionally molded into a non-planar three dimensional contoured configuration which conforms to the contours of the vehicle floor so as to fit properly. In order to make the carpeting moldable and shape-sustaining, it is conventionally provided with a backing of thermoplastic polymer composition. The thermoplastic polymer backing also serves as a barrier to improve the sound deadening properties of the carpet assembly.

Dash insulators are often mounted to a vehicle firewall which separates the passenger compartment from an engine compartment. Dash insulators are designed to reduce the transmission of noise and heat from the engine compartment into the passenger compartment. Conventional dash insulators consist of an acoustical absorber such as an open-cell polyurethane foam or a resinated fiber pad which faces the fire wall, and a barrier sheet such as a heavily filled thermoplastic material. Dash insulator barriers are conventionally produced in a compounding process followed by an extrusion or calendaring process or by an injection molding process to achieve a barrier sheet of desired thickness and width.

Conventional carpet systems and dash insulators typically include an ethylene-vinylacetate (EVA), polyethylene (PE), or polyvinylchloride (PVC) layer which serves as a barrier sheet. Unfortunately, there are several drawbacks associated with the use of EVA, PE, and

PVC layers in these vehicle applications. For example, EVA, PE, and PVC are non-porous materials which can be relatively heavy when applied to carpeting, dash insulators, and other interior trim components. In addition, EVA, PE, and PVC are conventionally applied in layers have a non-varying thickness. As such, some material may be wasted in areas where sound transmission is not problematic, thereby increasing weight unnecessarily.

Various sound attenuating materials have been developed for use in reducing noise levels within passenger compartments of vehicles. For example, U.S. Patent No. 4,851,283 to Holtrop et al., proposes a thermoformable laminate for use in headliners. The headliner comprises a non-woven fabric bonded to a foamed polymer sheet. The fabric is formed from a blend of low melting staple fibers and high melting staple fibers.

U.S. Patent No. 5,298,694 to Thompson proposes a non-woven acoustical insulation web. The web comprises thermoplastic fibers, and particularly a blend of melt-blown microfibers and crimped bulking fibers.

U.S. Patent No. 5,677,027 to Masuda et al., proposes a sound insulating structure comprising a covering layer, a panel, and a cushioning layer. The cushioning layer comprises a first fiber such as polyethylene terephthalate (PET) and a second fiber that is of a shell-core construction wherein the majority of the core is PET.

U.S. Patent No. 5,817,408 to Orimo et al., proposes a sound insulating structure which includes low and high density thermoplastic fibers. PET is preferred as a thermoplastic synthetic fiber.

U.S. Patent No. 4,529,639 to Peoples, Jr. et al. proposes a molded foam-backed carpet assembly which includes a carpet layer, a moldable thermoplastic polymer layer and one or more foam pads fusibly bonded to the

thermoplastic layer and extending over less than the entire surface of the thermoplastic polymer layer to provide desired cushioning and sound and thermal insulation only in preselected areas of the carpet.

5 In general, the ability of conventional materials to attenuate sound increases as the amount of material increases. Unfortunately, increased materials often increases the weight of sound attenuating material, which may be undesirable. Accordingly, there is a  
10 continuing need for acoustical insulation materials for use within vehicles that exhibit superior sound attenuating properties, while also being lightweight and low in cost.

#### 15 SUMMARY OF THE INVENTION

In view of the above discussion, sound attenuating and/or absorption laminates for use within vehicles such as floor coverings and other interior trim components, and methods of producing same, are provided.  
20 According to embodiments of the present invention, a sound attenuating laminate configured to be attached to an article, such as a vehicle panel, includes a substrate having a shape of the article, and polyurethane attached to selected portions of the substrate. The polyurethane  
25 is non-porous and serves as a barrier to attenuate sound passing through the substrate. Additional non-porous polyurethane may be added to one or more selected portions of the polyurethane layer to enhance sound attenuation characteristics in the one or more selected  
30 portions. According to embodiments of the present invention, one or more of the substrate surfaces may have recessed portions formed therein, and additional non-porous polyurethane may be applied in the one or more recessed portions to further enhance sound attenuation  
35 characteristics. According to embodiments of the present invention, one or more secondary articles (e.g., plastic

pass-throughs, etc.) may be molded-in with the substrate and additional non-porous polyurethane may be applied over the one or more molded-in articles to further enhance sound attenuation characteristics.

5           According to embodiments of the present invention, a sound absorption laminate configured to be attached to an article, such as a vehicle panel, includes a substrate having a shape of the article, and breathable polyurethane attached to selected portions of the  
10           substrate. The polyurethane serves as an absorber of sound (e.g., sound generated within a vehicle compartment). Additional breathable polyurethane may be added to one or more selected portions of the polyurethane layer to enhance sound absorption  
15           characteristics in the one or more selected portions. According to embodiments of the present invention, one or more of the substrate surfaces may have recessed portions formed therein, and additional breathable polyurethane may be applied in the one or more recessed portions to  
20           further enhance sound absorption characteristics.

          According to embodiments of the present invention, a porous, breathable carpet assembly (or dash insulator) for use in vehicles, is provided and includes a substrate and a porous carpet layer secured to the  
25           substrate. The substrate has opposite first and second surfaces and the porous carpet layer is adhesively secured to the substrate via a breathable polyurethane layer. The substrate first surface is configured to be attached to a vehicle panel in contacting face-to-face  
30           relationship therewith. The substrate may be formed into the shape of a vehicle floor panel (or vehicle firewall) such that the substrate first surface attaches to the vehicle floor panel (or firewall) in contacting face-to-face relationship therewith.

35           Breathable polyurethane may be applied onto the substrate second surface in one or more areas to enhance

sound absorption characteristics of the carpet assembly. Alternatively, or in addition to, non-porous polyurethane may be applied onto the substrate second surface in one or more areas to enhance sound attenuation characteristics of the carpet assembly (or dash insulator).

Sound attenuating and/or absorption laminates, sound absorbing carpet assemblies, and sound absorbing dash insulators, according to embodiments of the present invention, can provide desired sound deadening and absorption properties in selected vehicle locations, such as floor pans, door panels, firewalls, headliners, spare tire covers, etc. Moreover, sound attenuating and/or absorption laminates according to embodiments of the present invention may have reduced overall weight without sacrificing soundproofing properties.

#### BRIEF DESCRIPTION OF THE DRAWINGS

The accompanying drawings, which form a part of the specification, illustrate key embodiments of the present invention. The drawings and description together serve to fully explain the invention.

Fig. 1 is cross-sectional view of a portion of a sound attenuating laminate according to embodiments of the present invention.

Fig. 2 is cross-sectional view of a portion of a sound attenuating laminate according to other embodiments of the present invention.

Fig. 3 is cross-sectional view of a portion of a sound attenuating laminate according to other embodiments of the present invention.

Fig. 4 is cross-sectional view of a portion of a sound attenuating laminate according to other embodiments of the present invention.

Fig. 5 is cross-sectional view of a portion of a sound attenuating laminate according to other embodiments of the present invention.

5 Fig. 6 is a flowchart of operations for producing sound attenuating laminates of Figs. 1-4, according to embodiments of the present invention.

Fig. 7A is cross-sectional view of a portion of a sound absorption laminate according to embodiments of the present invention.

10 Fig. 7B is cross-sectional view of a portion of a sound absorption laminate according to other embodiments of the present invention.

15 Fig. 7C is cross-sectional view of a portion of a sound absorption laminate according to other embodiments of the present invention.

Fig. 8 is cross-sectional view of a portion of a sound absorbing laminate according to other embodiments of the present invention.

20 Fig. 9 is a flowchart of operations for producing sound attenuating laminates of Figs. 7A-7C, according to embodiments of the present invention.

Fig. 10 is cross-sectional view of a portion of a porous, breathable carpet assembly according to embodiments of the present invention.

25 Figs. 11-12 are perspective views of an exemplary carpet assembly for a vehicle according to embodiments of the present invention.

30 Fig. 13 is a perspective view of an exemplary dashboard insulator for a vehicle according to embodiments of the present invention.

Fig. 14 is a flowchart of operations for producing the carpet assembly of Figs. 10-12, according to embodiments of the present invention.

## DETAILED DESCRIPTION OF THE INVENTION

The present invention now is described more fully hereinafter with reference to the accompanying drawings, in which preferred embodiments of the invention are shown. This invention may, however, be embodied in many different forms and should not be construed as limited to the embodiments set forth herein; rather, these embodiments are provided so that this disclosure will be thorough and complete, and will fully convey the scope of the invention to those skilled in the art.

In the drawings, the thickness of lines, layers and regions may be exaggerated for clarity. It will be understood that when an element such as a layer, region, substrate, or panel is referred to as being "on" another element, it can be directly on the other element or intervening elements may also be present. In contrast, when an element is referred to as being "directly on" another element, there are no intervening elements present. It will be understood that when an element is referred to as being "connected" or "attached" to another element, it can be directly connected or attached to the other element or intervening elements may also be present. In contrast, when an element is referred to as being "directly connected" or "directly attached" to another element, there are no intervening elements present. The terms "upwardly", "downwardly", "vertical", "horizontal" and the like when used herein are for the purpose of explanation only.

Embodiments of the present invention provide sound attenuating and/or absorbing laminates and carpet assemblies for use in various applications, particularly automotive applications. Exemplary automotive applications within which sound attenuating and/or absorbing laminates and carpet assemblies according to embodiments of the present invention may be utilized

include, but are not limited to, floor coverings, door panels, dash insulators, trunk liners headliners, various interior trim components, etc.

Referring to Fig. 1, a section view of a portion of a sound attenuating laminate 10 that is configured to attenuate noise according to embodiments of the present invention, is illustrated. The sound attenuating laminate 10 includes a substrate 14 having opposite first and second surfaces 14a, 14b. The first surface 14a is attached to an article 12, such as a vehicle panel, in contacting face-to-face relationship therewith. A polyurethane barrier layer 16 is applied to selected portions 15 of the substrate second surface 14b, as illustrated. The polyurethane barrier layer 16 may also be applied to the entire second surface 14b of the substrate. The polyurethane barrier layer 16 is non-porous and is configured to attenuate sound passing through the article (e.g., vehicle panel) and through the substrate 14.

The polyurethane barrier layer 16 has a density of about 1.0 to 3.0 pcf and a thickness of about 15 to 30 mm. The polyurethane barrier layer 16 comprises an isocyanate, a polyol and various additives such as crosslinking agents, catalysts, blowing agents and the like, the selection of which will be within the skill of one in the art. For example, the isocyanate component of the polyurethane includes one or more compounds selected from the group consisting of diphenylmethane-4, 4'-diisocyanate, diphenyldimethylmethane-4, 4'-diisocyanate, phenylene-1, 4-diisocyanate, 2,2',6,6'-tetramethyldiphenylmethane-4,4'-diisocyanate, diphenyl-4, 4'diisocyanate, diphenylether-4, 4'-diisocyanate or its alkyl-, alkoxy- or halogen-substituted derivatives, toluylene-2, 4- and -2,6-diisocyanates or their commercially available mixture, 2,4-

diisocyclopropylphenylene-1, 3-diisocyanate, m-xylylenediisocyanate, and p-xylylenediisocyanate.

Further, in the practice of the present invention, any desired types of polyester polyols and polyether polyols may be used as a polyol component of the polyurethane prepolymer solution. Examples of the crosslinking agent usable in the present invention include trifunctional or more functional polyisocyanate or hydroxyl compounds, for example, one or more compounds selected from the group consisting of ethylene glycol, propylene glycol, butane-1, 4-diol, hexane-2, 5-diol, 2,2-dimethylpropane-1, 3-diol, hexane-1,6-diol, 2-methylhexane-1,6-diol, 2,2-dimethylhexane-1,3-diol, p-bishydroxymethyl cyclohexane, 3-methylpentane-1, 4-diol, 2,2-diethylpropane-1, 3-diol and the like. As the catalyst, tertiary amines, organic tin compounds, organic lead compounds and the like may be used. As the solvent capable of dissolving polyols and isocyanates, methyl ethyl ketone, ethyl acetate, toluene, xylene, dimethylformamide, methyl isobutyl ketone, butyl acetate, acetone or the like may be used alone or in combination. The polyurethane barrier layer 16 can be in the form of a slab foam, cast foam or a thermoformable foam.

According to embodiments of the present invention, the polyurethane may include a filler, such as calcium carbonate, calcium hydroxide, aluminum trihydrate, talc, bentonite, barytes, silica, clay and mica.

An exemplary unfilled polyurethane barrier material that may be used in accordance with embodiments of the present invention is Bayer Elastomer (Bayer AG, Pittsburgh, PA). An exemplary filled polyurethane barrier material that may be used in accordance with embodiments of the present invention is Huntsman Rimline SH 80309 (Huntsman Corporation, Salt Lake City, Utah).

The substrate 14 may be formed from any type of

material including, but not limited to foam (e.g., polyurethane foam, thermoplastic foam, etc.), massback, and other thermoformable fibrous materials including those derived from natural and synthetic fibers. Massback is a relatively dense material, normally impermeable to air and thermoformable. Massback can be formed from virtually any plastic or rubber material which contains a high-mass filler material. An exemplary massback includes ethylene-vinylacetate (EVA) copolymer, polyethylene, or polyvinyl-chloride (PVC), and a high-mass filler material, such as glass, calcium carbonate or barium sulfate, added to increase the mass. Other suitable materials for the substrate include thermoformable stiff thermoplastic materials such as polystyrene, polyphenyl sulfide and polycarbonate, fiber-reinforced thermoplastics and fiber-reinforced thermosets such as epoxies, phenolics and the like.

The substrate 14 may be formed into a three-dimensional shape of the article 12 such that the substrate first surface 14a attaches to the article 12 in contacting face-to-face relationship therewith. The substrate 14 can have form retention characteristics such that it maintains a form imposed upon it. Alternatively, the substrate 14 may have elastic memory such that it is unable to maintain an unassisted non-flat configuration. For substrate materials having elastic memory, the polyurethane barrier layer 16 also serves the function of a binder such that the substrate 14 can maintain a shape imposed upon it via molding and other operations.

The article 12 may be virtually any type of vehicle panel (e.g., floor panel, firewall, door panel, wheel well, trunk compartment panel, etc.). For example, a sound attenuating laminate 10 according to embodiments of the present invention may be utilized as a dash insulator when attached to a vehicle firewall, may be

utilized as a floor covering when attached to vehicle floor panels, and may be utilized as virtually any type of vehicle interior trim component.

Vehicle panels to which sound attenuating laminates according to the present invention may be attached may have various shapes, configurations, and sizes, and may be formed of various materials including, but not limited to metals, polymers, and combinations thereof. For example, a vehicle panel may be sheet metal having a three-dimensional configuration. Alternatively, a vehicle panel may be a substantially flat piece of sheet metal.

Referring to Fig. 2, a sound attenuating laminate 110 according to other embodiments of the present invention is illustrated. The illustrated sound attenuating laminate 110 includes a substrate 14 having opposite first and second surfaces 14a, 14b. The first surface 14a is attached to an article 12, such as a vehicle panel, as illustrated. A polyurethane barrier layer 16 is applied to the substrate second surface 14b, and additional polyurethane 16' is added to a selected portion 17 of the polyurethane layer 16. Both the polyurethane barrier layer 16 and the additional polyurethane 16' are preferably non-porous polyurethane and are configured to attenuate sound passing through the article 12 and through the substrate 14. The additional polyurethane 16' is added to a specific location determined to require additional sound attenuation.

Referring to Fig. 3, a sound attenuating laminate 210 according to other embodiments of the present invention is illustrated. The illustrated sound attenuating laminate 210 includes a substrate 14 having opposite first and second surfaces 14a, 14b. The first surface 14a is attached to an article 12, such as a vehicle panel, as illustrated. A polyurethane barrier

layer 16 is applied to the substrate second surface 14b, and additional polyurethane 16' is disposed within a recess 19 formed within the substrate first surface 14a. Both the polyurethane barrier layer 16 and the additional polyurethane 16' are non-porous polyurethane and are configured to attenuate sound passing through the article 12 and through the substrate 14. The additional polyurethane 16' is added to the recess 19 to enhance sound attenuation characteristics of the sound attenuating laminate 210 in the area of the recess 19.

Referring to Fig. 4, a sound attenuating laminate 310 according to other embodiments of the present invention is illustrated. The illustrated sound attenuating laminate 310 includes a substrate 14 having opposite first and second surfaces 14a, 14b. A recess 21 is formed within the substrate second surface 14b. The first surface 14a is attached to an article 12, such as a vehicle panel, as illustrated. A polyurethane barrier layer 16 is applied to the substrate second surface 14b such that it also fills the recess 21 formed within the substrate second surface 14b. The polyurethane barrier layer 16 is a non-porous polyurethane and is configured to attenuate sound passing through the article 12 and through the substrate 14. The additional polyurethane 16 due to the recess 21 enhances sound attenuation characteristics of the sound attenuating laminate 310 in the area of the recess 21.

Sound attenuating laminates according to embodiments of the present invention illustrated in Figs. 3-4 can have various numbers of recesses filled with non-porous polyurethane. Moreover, recesses filled with non-porous polyurethane may have various configurations and/or sizes.

Referring to Fig. 5, a sound attenuating

laminates 410 according to other embodiments of the present invention is illustrated. The illustrated sound attenuating laminate 410 includes a substrate 14 having opposite first and second surfaces 14a, 14b. A secondary article (e.g., a plastic pass-through) 23 is molded-in with the substrate 410. The first surface 14a is attached to an article 12, such as a vehicle panel, as illustrated. In the illustrated embodiment, the article 12 includes an aperture that is in communication with the aperture in the secondary article 23. Accordingly, an item, such as a cable, can be extended through the article aperture and through the sound attenuating laminate 410.

A polyurethane barrier layer 16 is applied to the substrate second surface 14b such that it overlies the molded-in secondary article 23 and surrounding area. The polyurethane barrier layer 16 is a non-porous polyurethane and is configured to attenuate sound passing through the article 12 and through the substrate 14. The additional polyurethane 16 enhances sound attenuation characteristics of the sound attenuating laminate 410 in the area of the molded-in secondary article 23. Secondary articles molded-in with substrates according to embodiments of the present invention can have various sizes, shapes, and configurations.

Referring now to Fig. 6, operations for forming sound attenuating laminates, according to embodiments of the present invention, are illustrated. The acoustic properties of an article, such as a vehicle panel, on which a sound attenuating laminate is to be placed are ascertained to identify areas requiring additional sound attenuation characteristics. (Block 1000). Acoustic properties of an article may be ascertained by identifying areas of an article through which sound within a predetermined frequency range passes at an

intensity level that exceeds a threshold intensity level. Identifying areas of an article through which sound within a predetermined frequency range passes at an intensity level that exceeds a threshold intensity level may include generating a sound intensity map of the article. Sound intensity maps are well understood by those skilled in the art and need not be described further herein.

A substrate configured to be attached to the article in face-to-face contacting relationship is formed into a shape corresponding to that of the article (Block 1010). Areas of the substrate in which apertures are to be formed therethrough may be identified (Block 1020). Polyurethane is then applied (e.g., via spraying or other application techniques) to the substrate in areas identified as requiring enhanced sound attenuation characteristics (Block 1030). Areas of the substrate in which apertures are to be formed therethrough are preferably avoided during the application of the polyurethane barrier layer. Additional polyurethane may be added to areas identified as requiring additional sound attenuation characteristics (Block 1040). This may encompass applying additional polyurethane directly onto an existing polyurethane barrier layer and/or into one or more recessed portions formed within the substrate.

According to embodiments of the present invention, various ones of the operations illustrated in Fig. 6 may be performed out of the illustrated order. For example, polyurethane may be added to various portions of a substrate prior to forming (*i.e.*, molding) operations. As another example, a substrate may be formed prior to the application of any polyurethane. As another example, polyurethane may be applied within a mold and additional polyurethane added in selected locations. A substrate may then be attached to the polyurethane and the composite article formed via the mold into a desired shape.

Furthermore, operations represented by Blocks 1030 and 1040 may be performed substantially simultaneously. For example, additional polyurethane can be added by adjusting processing speeds and/or by  
5 adjusting dispensing pressure, as would be understood by those skilled in the art.

Referring now to Figs. 7A-7C, section views of portions of sound absorbing laminates, according to embodiments of the present invention, are illustrated. In  
10 Fig. 7A, a sound absorbing laminate 40 includes a substrate 44 having opposite first and second surfaces 44a, 44b, and a layer of breathable polyurethane 46 disposed on the substrate second surface 44b. In the illustrated embodiment, the substrate first surface 44a  
15 is attached to an article 42 (e.g., a vehicle panel) in face-to-face relationship therewith. The breathable polyurethane layer 46 is configured to enhance sound absorption characteristics. For example, sound generated within a vehicle can be absorbed by the sound absorbing  
20 laminate 40 to provide a quieter environment within the vehicle.

The breathable polyurethane layer 46 has a density of about 1.0 to 3.0 pcf and a thickness of about 15 to 30 mm. The breathable polyurethane layer 46  
25 comprises an isocyanate, a polyol and various additives such as crosslinking agents, catalysts, blowing agents and the like, the selection of which will be within the skill of one in the art. For example, the isocyanate component of the polyurethane includes one or more  
30 compounds selected from the group consisting of diphenylmethane-4, 4'-diisocyanate, diphenyldimethylmethane-4, 4'-diisocyanate, phenylene-1, 4-diisocyanate, 2,2',6,6'-tetramethyldiphenylmethane-4,4'-diisocyanate, diphenyl-4, 4'diisocyanate,  
35 diphenylether-4, 4'-diisocyanate or its alkyl-, alkoxy-

or halogen-substituted derivatives, toluylene-2, 4- and -  
2,6-diisocyanates or their commercially available  
mixture, 2,4-diisocyclopropylphenylene-1, 3-diisocyanate, m-  
xylylenediisocyanate, and p-xylylenediisocyanate.

5 Further, in the practice of the present  
invention, any desired types of polyester polyols and  
polyether polyols may be used as a polyol component of  
the polyurethane prepolymer solution. Examples of the  
crosslinking agent usable in the present invention  
10 include trifunctional or more functional polyisocyanate  
or hydroxyl compounds, for example, one or more compounds  
selected from the group consisting of ethylene glycol,  
propylene glycol, butane-1, 4-diol, hexane-2, 5-diol,  
2,2-dimethylpropane-1, 3-diol, hexane-1,6-diol, 2-  
15 methylhexane-1,6-diol, 2,2-dimethylhexane-1,3-diol, p-  
bishydroxymethyl cyclohexane, 3-methylpentane-1, 4-diol,  
2,2-diethylpropane-1, 3-diol and the like. As the  
catalyst, tertiary amines, organic tin compounds, organic  
lead compounds and the like may be used. As the solvent  
20 capable of dissolving polyols and isocyanates, methyl  
ethyl ketone, ethyl acetate, toluene, xylene,  
dimethylformamide, methyl isobutyl ketone, butyl acetate,  
acetone or the like may be used alone or in combination.  
The breathable polyurethane layer 46 can be in the form  
25 of a slab foam, cast foam or a thermoformable foam.

According to embodiments of the present  
invention, the breathable polyurethane layer 46 may  
include a filler such as calcium carbonate, calcium  
hydroxide, aluminum trihydrate, talc, bentonite, barytes,  
30 silica, clay and mica.

An exemplary breathable polyurethane material  
that may be used in accordance with embodiments of the  
present invention is Bayer Baypreg SA (Bayer AG,  
Pittsburgh, PA).

35 The substrate 44 may be formed from any type of  
material including, but not limited to foam (e.g.,

polyurethane foam, thermoplastic foam, etc.), massback, and other thermoformable fibrous materials including those derived from natural and synthetic fibers. Massback is a relatively dense material, normally impermeable to air and thermoformable. Massback can be formed from virtually any plastic or rubber material which contains a high-mass filler material. An exemplary massback includes ethylene-vinylacetate (EVA) copolymer, polyethylene, or polyvinyl-chloride (PVC), and a high-mass filler material, such as glass, calcium carbonate or barium sulfate, added to increase the mass. Other suitable materials for the substrate include thermoformable stiff thermoplastic materials such as polystyrene, polyphenyl sulfide and polycarbonate, fiber-reinforced thermoplastics and fiber-reinforced thermosets such as epoxies, phenolics and the like.

The substrate 44 may be formed into the shape of the article 42 such that the substrate first surface 44a attaches to the article 42 in contacting face-to-face relationship therewith. The substrate 44 can have form retention characteristics such that it maintains a form imposed upon it. Alternatively, the substrate 44 may have elastic memory such that it is unable to maintain an unassisted non-flat configuration. For substrate materials having elastic memory, the layer of breathable polyurethane 46 also serves the function of a binder such that the substrate 44 can maintain a shape imposed upon it via molding and other operations.

As illustrated in Fig. 7B, a sound absorbing laminate 140, according to embodiments of the present invention may include additional breathable polyurethane 46' added to one or more selected portions 47 of the layer of breathable polyurethane 46. Both the layer of breathable polyurethane 46 and the additional polyurethane 46' are configured to absorb sound. The

additional polyurethane 46' is added to a specific location determined to require additional sound absorption.

5 As illustrated in Fig. 7C, a sound absorbing laminate 240, according to embodiments of the present invention may include upholstery material 48 attached to the polyurethane layer 46 in face-to-face contacting relationship therewith.

10 According to embodiments of the present invention, the sound absorbing laminates of Figs. 7A-7C may include one or more recessed portions formed within the substrate and additional breathable polyurethane is disposed therewithin as described above with respect to the sound attenuating laminate embodiments of Figs. 1-4.  
15 In addition, according to embodiments of the present invention, the sound absorbing laminates of Figs. 7A-7C may include one or more molded-in secondary articles within the substrate and additional breathable polyurethane may be disposed thereon and/or therearound  
20 as described above with respect to the sound attenuating laminate embodiments of Figs. 1-4.

The article 42 to which sound absorbing laminates 40, 140, 240 according to the embodiments of Figs. 7A-7C may be attached may be virtually any type of  
25 vehicle panel (e.g., floor panels, firewalls, door panels, wheel wells, trunk compartment panels, spare tire covers, headliners, etc.): For example, a sound absorbing laminate according to embodiments of the present invention may be utilized as a dash insulator when  
30 attached to a vehicle firewall, may be utilized as a floor covering when attached to vehicle floor panels, and may be utilized as virtually any type of vehicle interior trim component. Vehicle panels to which sound absorbing laminates illustrated in Figs. 7A-7C may be attached may  
35 have various shapes, configurations, and sizes, and may

be formed of various materials including, but not limited to metals, polymers, and combinations thereof. For example, a vehicle panel may be sheet metal having a three-dimensional configuration. Alternatively, a vehicle panel may be a substantially flat piece of sheet metal.

Referring to **Fig. 8**, a sound absorbing laminate 340 according to other embodiments of the present invention is illustrated. The illustrated sound absorbing laminate 340 includes a substrate 44 having opposite first and second surfaces 44a, 44b, and a layer of breathable polyurethane 46 disposed on the substrate second surface 44b. A secondary article (e.g., a plastic pass-through) 23 is molded-in with the substrate 340. In the illustrated embodiment, the article 42 includes an aperture that is in communication with the aperture in the secondary article 23. Accordingly, an item, such as a cable, can be extended through the article aperture and through the sound absorbing laminate 340. The breathable polyurethane layer 46 overlies the molded-in secondary article 23 and surrounding area and is configured to enhance sound absorption characteristics. For example, sound generated within a vehicle can be absorbed by the sound absorbing laminate 40 to provide a quieter environment within the vehicle. Secondary articles molded-in with substrates according to embodiments of the present invention can have various sizes, shapes, and configurations.

Referring now to **Fig. 9**, operations for forming sound absorbing laminates, according to embodiments of the present invention, are illustrated. The acoustic properties of a vehicle within which a sound absorbing laminate is to be placed are ascertained to identify areas that require additional sound absorption characteristics. (Block 2000).

A substrate configured to be attached to the

article in face-to-face contacting relationship is formed into a shape corresponding to that of the article. (Block 2010). Areas of the substrate in which apertures are to be formed therethrough may be identified. (Block 2020).

5 Breathable polyurethane is then applied (e.g., via spraying or other application techniques) to the substrate in areas identified as requiring enhanced sound absorption characteristics. (Block 2030). Areas of the substrate in which apertures are to be formed  
10 therethrough are preferably avoided during the application of the polyurethane barrier layer. Additional polyurethane may be added to areas identified as requiring additional sound absorption characteristics (Block 2040). This may encompass applying additional  
15 breathable polyurethane directly onto an existing layer of breathable polyurethane and/or into one or more recessed portions formed within the substrate.

According to embodiments of the present invention, various ones of the operations illustrated in  
20 Fig. 9 may be performed out of the illustrated order. For example, polyurethane may be added to various portions of a substrate prior to forming (*i.e.*, molding) operations. As another example, a substrate may be formed prior to the application of any polyurethane. As another example,  
25 polyurethane may be applied within a mold and additional polyurethane added in selected locations. A substrate may then be attached to the polyurethane and the composite article formed via the mold into a desired shape.

Furthermore, operations represented by Blocks  
30 2030 and 2040 may be performed substantially simultaneously. For example, additional polyurethane can be added by adjusting processing speeds and/or by adjusting dispensing pressure, as would be understood by those skilled in the art.

35 Referring now to Fig. 10, a section view of a

portion of sound absorbing carpet assembly 50, according to embodiments of the present invention, are illustrated. The sound absorbing carpet assembly 50 includes a substrate 54 having opposite first and second surfaces 54a, 54b. A porous carpet layer 58 is adhesively secured to the substrate, either via a breathable polyurethane layer 56, or via another adhesive layer (not shown). The illustrated carpet layer 58 includes a backing 60 and carpet tufts 62 extending from the backing 60. The backing 60 is in contacting face-to-face relationship with the breathable polyurethane layer 56.

The substrate first surface 54a is configured to be attached to a vehicle floor panel 52 in contacting face-to-face relationship therewith. The substrate 54 may be formed from any type of material including, but not limited to foam (e.g., polyurethane foam, thermoplastic foam, etc.), massback, and other thermoformable fibrous materials including those derived from natural fibers, man-made fibers, and/or blends of natural fiber and man-made fibers.

The substrate 54 may be formed into the shape of a vehicle floor panel 52 such that the substrate first surface 54a attaches to the vehicle floor panel 52 in contacting face-to-face relationship therewith. The substrate 54 can have form retention characteristics such that it maintains a form imposed upon it. Alternatively, the substrate 54 may have elastic memory such that it is unable to maintain an unassisted non-flat configuration. For substrate materials having elastic memory, the breathable polyurethane layer 56 also serves the function of a binder such that the substrate 54 can maintain a shape imposed upon it via molding and other operations.

An exemplary porous, breathable carpet assembly 50 is illustrated in Fig. 11. The illustrated carpet assembly 50 has a non-planar three dimensional molded

configuration adapted to fit the front seat compartment floor of a vehicle and includes a raised medial portion 61 adapted to conform to the transmission hump, generally vertically extending side portions 62 adapted to fit  
5 beneath each door opening, and a front portion 63 adapted to fit along the inclined floorboard and vertical firewall areas of a vehicle. Various openings or cut-outs are provided, as indicated at 64, to receive air conditioning equipment, the steering column, pedals and  
10 the like. It is to be understood that the particular three dimensional configuration illustrated is merely for purposes of illustration. Carpet assemblies according to embodiments of the present invention may have various configurations and shapes depending on the floor  
15 configuration of a vehicle.

Referring to Fig. 12, additional polyurethane 70 is added to one or more selected portions of the substrate first surface 54a of the carpet assembly 50. The additional polyurethane 70 may be a breathable  
20 polyurethane such that sound absorption characteristics of the carpet assembly 50 are enhanced. Alternatively, The additional polyurethane 70 may be a non-porous polyurethane such that sound attenuation characteristics of the carpet assembly 50 are enhanced. Moreover, there  
25 may be a combination of breathable polyurethane and non-porous polyurethane such that both sound absorption and sound attenuation characteristics of the carpet assembly 50 are enhanced.

An exemplary porous, breathable dashboard  
30 insulator 80 is illustrated in Fig. 13. The illustrated dashboard insulator 80 has a non-planar three dimensional molded configuration adapted to fit the firewall of a vehicle. Various openings or cut-outs are provided, as indicated at 64, to receive air conditioning equipment,  
35 the steering column, pedals and the like. It is to be

understood that the particular three dimensional configuration illustrated is merely for purposes of illustration. Dashboard insulators according to embodiments of the present invention may have various configurations and shapes depending on the firewall configuration of a vehicle. Additional polyurethane may be added to one or more selected portions of the dashboard insulator as described above. The additional polyurethane may be a breathable polyurethane such that sound absorption characteristics of the dashboard insulator 80 are enhanced. Alternatively, the additional polyurethane may be a non-porous polyurethane such that sound attenuation characteristics of the dashboard insulator 80 are enhanced. Moreover, there may be a combination of breathable polyurethane and non-porous polyurethane such that both sound absorption and sound attenuation characteristics of the dashboard insulator 80 are enhanced.

Referring now to Fig. 14, operations for producing a carpet assembly 50 (Figs. 10-12) for use in vehicles, according to embodiments of the present invention, are illustrated. The acoustic properties of a vehicle within which a carpet assembly is to be utilized are ascertained. (Block 3000). A substrate having opposite first and second surfaces is provided, wherein the substrate first surface is configured to be attached to a vehicle panel in contacting face-to-face relationship therewith (Block 3010). A layer of uncured, breathable polyurethane is applied onto the substrate second surface (Block 3020). A porous carpet layer is attached to the substrate such that the carpet layer backing is in contacting face-to-face relationship with the breathable polyurethane layer (Block 3030). The carpet layer and substrate are then formed into a desired shape (Block 3040). The breathable polyurethane layer is

then subjected to conditions sufficient to cure breathable polyurethane layer such that the substrate and carpet layer are bonded together to form a porous, breathable carpet assembly having the desired shape (Block 3050). For example, heat and/or other energy forms (e.g., microwave energy) may be applied to cure the polyurethane layer.

Breathable polyurethane may be applied onto the substrate second surface in one or more areas to enhance sound absorption characteristics of the carpet assembly (Block 3060). Alternatively, or in addition to, non-porous polyurethane may be applied onto the substrate second surface in one or more areas to enhance sound attenuation characteristics of the carpet assembly (Block 3070).

Sound attenuating laminates and sound absorbing laminates according to the various embodiments of the present invention facilitate acoustical "tuning" wherein acoustical "hot spots" can be identified and additional material (i.e., non-porous polyurethane to provide a barrier to sound, and/or breathable polyurethane to absorb sound) can be added to attenuate sound. Sound attenuating laminates according to embodiments of the present invention can be "tuned" to provide desired sound attenuating characteristics in selected vehicle locations, such as floor panels, firewalls, door panels, wheel wells, trunk compartment panels, etc. The term "tuned" means that portions of a sound attenuating and/or absorbing laminate can be formed to have a specific acoustic impedance designed to attenuate sound in one or more frequencies or frequency bands, and/or to have a specific absorption characteristic designed to absorb sound in one or more frequencies or frequency bands. Moreover, sound attenuating/absorption laminates according to embodiments of the present invention may have reduced overall weight compared with conventional

sound proofing materials, and without sacrificing sound attenuation properties.

The foregoing is illustrative of the present invention and is not to be construed as limiting thereof.

5 Although a few exemplary embodiments of this invention have been described, those skilled in the art will readily appreciate that many modifications are possible in the exemplary embodiments without materially departing from the novel teachings and advantages of this  
10 invention. Accordingly, all such modifications are intended to be included within the scope of this invention as defined in the claims. Therefore, it is to be understood that the foregoing is illustrative of the present invention and is not to be construed as limited  
15 to the specific embodiments disclosed, and that modifications to the disclosed embodiments, as well as other embodiments, are intended to be included within the scope of the appended claims. The invention is defined by the following claims, with equivalents of the claims to  
20 be included therein.

## THAT WHICH IS CLAIMED IS:

1. A method of forming a sound attenuating laminate, comprising:

ascertaining acoustic properties of an article on which the sound attenuating laminate is to be placed  
5 to identify areas wherein additional sound attenuation characteristics are necessary;

forming a substrate in the shape of the article; and

10 applying polyurethane on the substrate, wherein the polyurethane is applied substantially only in the identified areas wherein enhanced sound attenuation characteristics are required.

2. The method of Claim 1, wherein the substrate comprises thermoformable fibrous material.

3. The method of Claim 1, wherein the polyurethane is applied by spraying.

4. The method of Claim 3, wherein the polyurethane comprises a filler selected from the group consisting of calcium carbonate, calcium hydroxide, aluminum trihydrate, talc, bentonite, barytes, silica,  
5 clay and mica.

5. The method of Claim 1, wherein the article is a firewall and the sound attenuating laminate is a dashboard insulator.

6. The method of Claim 1, wherein the article is a vehicle floor and the sound attenuating laminate is a floor covering.

7. The method of Claim 1, wherein the article is a vehicle panel and the sound attenuating laminate is a vehicle interior trim component.

8. The method of Claim 1, wherein ascertaining acoustic properties of an article comprises identifying areas of the article through which sound within a predetermined frequency range passes at an intensity level that exceeds a threshold intensity level.

9. The method of Claim 8, wherein the substrate comprises opposite first and second surfaces and is configured to be attached to the article in face-to-face relationship therewith, and wherein applying polyurethane on the substrate comprises applying polyurethane onto the substrate first surface.

10. The method of Claim 1, wherein applying polyurethane on the substrate comprises:  
applying polyurethane on the substrate to form a polyurethane layer having a substantially constant thickness; and  
spraying additional polyurethane on one or more selected portions of the polyurethane layer.

11. The method of Claim 1, wherein applying polyurethane on the substrate comprises applying polyurethane on the substrate to form a polyurethane layer having a first thickness in a first portion and a second thickness greater than the first thickness in a second portion.

12. The method of Claim 1, wherein ascertaining acoustic properties of an article on which the sound attenuating laminate is to be placed to identify areas wherein enhanced sound attenuation

5 characteristics are required comprises generating a sound intensity map of the article.

13. The method of Claim 1, wherein applying polyurethane on the substrate comprises:

identifying areas of the substrate in which apertures are to be formed; and

5 avoiding the identified areas when applying the polyurethane onto the substrate.

14. The method of Claim 1, wherein the substrate has one or more recessed portions formed therein, and wherein applying polyurethane onto the substrate comprises applying polyurethane into the one or

5 more recessed portions.

15. The method of Claim 1, wherein forming a substrate in the shape of the article comprises integrally forming a secondary article with the substrate, and wherein applying polyurethane onto the

5 substrate comprises applying polyurethane into areas adjacent the secondary article.

16. A method of forming a sound attenuating laminate, comprising:

ascertaining acoustic properties of an article on which the sound attenuating laminate is to be placed

5 to identify areas wherein additional sound attenuation characteristics are necessary;

applying a layer of polyurethane within a mold; applying additional polyurethane to the polyurethane layer at selected locations where enhanced

10 sound attenuation characteristics are required;

attaching a substrate to the layer of polyurethane; and

forming the substrate and polyurethane into a

sound attenuating laminate having a shape of the article.

17 The method of Claim 16, wherein the substrate comprises thermoformable fibrous material.

18. The method of Claim 16, wherein the polyurethane is applied by spraying.

19. The method of Claim 18, wherein the polyurethane comprises a filler selected from the group consisting of calcium carbonate, calcium hydroxide, aluminum trihydrate, talc, bentonite, barytes, silica, clay and mica.

20. The method of Claim 16, wherein the article is a firewall and the sound attenuating laminate is a dashboard insulator.

21. The method of Claim 16, wherein the article is a vehicle floor and the sound attenuating laminate is a floor covering.

22. The method of Claim 16, wherein the article is a vehicle panel and the sound attenuating laminate is a vehicle interior trim component.

23. The method of Claim 16, wherein ascertaining acoustic properties of an article comprises identifying areas of the article through which sound within a predetermined frequency range passes at an intensity level that exceeds a threshold intensity level.

24. The method of Claim 23, wherein the substrate comprises opposite first and second surfaces and is configured to be attached to the article in face-to-face relationship therewith, and wherein applying

5 polyurethane on the substrate comprises applying  
polyurethane onto the substrate first surface.

25. The method of Claim 16, wherein  
ascertaining acoustic properties of an article on which  
the sound attenuating laminate is to be placed to  
identify areas wherein enhanced sound attenuation  
5 characteristics are required comprises generating a sound  
intensity map of the article.

26. The method of Claim 16, wherein forming  
the substrate and polyurethane into a sound attenuating  
laminate having a shape of the article comprises  
integrally forming a secondary article within the  
5 substrate.

27. A sound attenuating laminate configured to  
be attached to an article, comprising:  
a substrate having a shape of the article; and  
polyurethane attached to selected portions of  
5 the substrate, wherein the polyurethane is non-porous and  
is configured to attenuate sound passing through the  
substrate.

28. The sound attenuating laminate of Claim  
27, wherein the substrate comprises thermoformable  
fibrous material.

29. The sound attenuating laminate of Claim  
27, wherein the polyurethane comprises a filler selected  
from the group consisting of calcium carbonate, calcium  
hydroxide, aluminum trihydrate, talc, bentonite, barytes,  
5 silica, clay and mica.

30. The sound attenuating laminate of Claim  
27, wherein the polyurethane comprises:

a layer of polyurethane having a substantially constant thickness; and

5 additional non-porous polyurethane added to one or more selected portions of the polyurethane layer.

31. The sound attenuating laminate of Claim 27, wherein the polyurethane comprises a layer of polyurethane having a first thickness in a first portion and a second thickness greater than the first thickness  
5 in a second portion.

32. The sound attenuating laminate of Claim 27, wherein the substrate comprises opposite first and second surfaces, wherein the first surface is configured to be attached to the article in contacting face-to-face  
5 relationship therewith, and wherein the polyurethane is attached to selected portions of the substrate second surface.

33. The sound attenuating laminate of Claim 32, further comprising additional non-porous polyurethane added to one or more selected portions of the polyurethane.

34. The sound attenuating laminate of Claim 32, wherein the substrate first surface has one or more recessed portions formed therein, and wherein polyurethane is applied in the one or more recessed  
5 portions.

35. The sound attenuating laminate of Claim 32, wherein the substrate second surface has one or more recessed portions formed therein, and wherein polyurethane is applied in the one or more recessed  
5 portions.

36. The sound attenuating laminate of Claim 32, wherein the substrate comprises a secondary article integrally formed therewithin and further comprising polyurethane applied to the substrate at one or more areas adjacent the secondary article.

37. The sound attenuating laminate of Claim 27, wherein the article is a firewall and the sound attenuating laminate is a dashboard insulator.

38. The sound attenuating laminate of Claim 27, wherein the article is a vehicle floor and the sound attenuating laminate is a floor covering.

39. The sound attenuating laminate of Claim 27, wherein the article is a vehicle panel and the sound attenuating laminate is a vehicle interior trim component.

40. A vehicle, comprising:  
a panel; and  
a sound attenuating laminate attached to the panel, wherein the sound attenuating laminate comprises:  
a substrate having a shape of the panel;  
and  
polyurethane attached to selected portions of the substrate, wherein the polyurethane is non-porous and is configured to attenuate sound passing through the vehicle panel and substrate.

41. The vehicle of Claim 40, wherein the substrate comprises thermoformable fibrous material.

42. The vehicle of Claim 40, wherein the polyurethane comprises a filler selected from the group

consisting of calcium carbonate, calcium hydroxide,  
aluminum trihydrate, talc, bentonite, barytes, silica,  
5 clay and mica.

43. The vehicle of Claim 40, wherein the  
polyurethane comprises:

a layer of polyurethane having a substantially  
constant thickness; and

5 additional non-porous polyurethane added to one  
or more selected portions of the polyurethane layer.

44. The vehicle of Claim 40, wherein the  
polyurethane comprises a layer of polyurethane having a  
first thickness in a first portion and a second thickness  
greater than the first thickness in a second portion.

45. The vehicle of Claim 40, wherein the  
substrate comprises opposite first and second surfaces,  
wherein the first surface is configured to be attached to  
the panel in contacting face-to-face relationship  
5 therewith, and wherein the polyurethane is attached to  
selected portions of the substrate second surface.

46. The vehicle of Claim 45, further  
comprising additional non-porous polyurethane added to  
one or more selected portions of the polyurethane.

47. The vehicle of Claim 45, wherein the  
substrate first surface has one or more recessed portions  
formed therein, and wherein polyurethane is applied in  
the one or more recessed portions.

48. The vehicle of Claim 45, wherein the  
substrate second surface has one or more recessed  
portions formed therein, and wherein polyurethane is  
applied in the one or more recessed portions.

49. The vehicle of Claim 45, wherein the substrate comprises a secondary article integrally formed therewithin and further comprising polyurethane applied to the substrate at one or more areas adjacent the secondary article.

50. The vehicle of Claim 40, wherein the panel is a firewall and the sound attenuating laminate is a dashboard insulator.

51. The vehicle of Claim 40, wherein the panel is a vehicle floor and the sound attenuating laminate is a floor covering.

52. A method of forming a sound absorbing laminate, comprising:

ascertaining acoustic properties of an article on which the sound absorbing laminate is to be placed to identify areas wherein additional sound absorption characteristics are necessary;

forming a substrate in the shape of the article, wherein the substrate comprises opposite first and second surfaces, and wherein the substrate first surface is configured to be attached to the article in face-to-face relationship therewith; and

applying a layer of breathable polyurethane on the substrate second surface, wherein the polyurethane is applied substantially only in the identified areas wherein enhanced sound absorption characteristics are required.

53. The method of Claim 52, further comprising attaching upholstery material to the polyurethane layer.

54. The method of Claim 52, wherein the substrate comprises thermoformable fibrous material.

55. The method of Claim 52, wherein the polyurethane is applied by spraying.

56. The method of Claim 52, wherein the polyurethane comprises a filler selected from the group consisting of calcium carbonate, calcium hydroxide, aluminum trihydrate, talc, bentonite, barytes, silica, clay and mica.

57. The method of Claim 52, wherein the article is a vehicle firewall and the sound absorbing laminate is a dashboard insulator.

58. The method of Claim 52, wherein the article is a vehicle floor and the sound absorbing laminate is a floor covering.

59. The method of Claim 52, wherein the article is a vehicle panel and the sound absorbing laminate is a vehicle interior trim component.

60. The method of Claim 52, wherein applying polyurethane on the substrate comprises:

5 applying polyurethane on the substrate to form a polyurethane layer having a substantially constant thickness; and

spraying additional polyurethane on one or more selected portions of the polyurethane layer.

61. The method of Claim 52, wherein applying polyurethane on the substrate comprises applying polyurethane on the substrate to form a polyurethane layer having a first thickness in a first portion and a second thickness greater than the first thickness in a second portion.

62. The method of Claim 52, wherein applying polyurethane on the substrate comprises:

identifying areas of the substrate in which apertures are to be formed; and

5 avoiding the identified areas when applying the polyurethane onto the substrate.

63. The method of Claim 52, wherein the substrate has one or more recessed portions formed therein, and wherein applying polyurethane onto the substrate comprises applying polyurethane into the one or  
5 more recessed portions.

64. The method of Claim 52, wherein forming a substrate in the shape of the article comprises integrally forming a secondary article with the substrate, and wherein applying polyurethane onto the  
5 substrate comprises applying polyurethane into areas adjacent the secondary article.

65. A method of forming a sound absorbing laminate, comprising:

ascertaining acoustic properties of an article on which the sound absorbing laminate is to be placed to  
5 identify areas wherein additional sound absorption characteristics are necessary;

applying a layer of breathable polyurethane within a mold;

10 applying additional breathable polyurethane to the breathable polyurethane layer at selected locations where enhanced sound absorption characteristics are required;

attaching a substrate to the layer of breathable polyurethane; and

15 forming the substrate and breathable polyurethane via the mold into a sound absorbing laminate

having a shape of the article, wherein the substrate is configured to be attached to the article in face-to-face relationship therewith.

66. The method of Claim 65, further comprising attaching upholstery material to the sound absorbing laminate.

67. The method of Claim 65, wherein the substrate comprises thermoformable fibrous material.

68. The method of Claim 65, wherein the polyurethane is applied by spraying.

69. The method of Claim 65, wherein the polyurethane comprises a filler selected from the group consisting of calcium carbonate, calcium hydroxide, aluminum trihydrate, talc, bentonite, barytes, silica, clay and mica.

70. The method of Claim 65, wherein the article is a vehicle firewall and the sound absorbing laminate is a dashboard insulator.

71. The method of Claim 65, wherein the article is a vehicle floor and the sound absorbing laminate is a floor covering.

72. The method of Claim 65, wherein the article is a vehicle panel and the sound absorbing laminate is a vehicle interior trim component.

73. A sound absorbing laminate, comprising:  
a substrate in the shape of an article, wherein the substrate comprises opposite first and second surfaces, and wherein the substrate first surface is

5 configured to be attached to the article in face-to-face relationship therewith; and

a layer of breathable polyurethane on the substrate second surface, wherein the polyurethane is configured to enhance sound absorption characteristics.

74. The sound absorbing laminate of Claim 73, further comprising upholstery material attached to the polyurethane layer in face-to-face contacting relationship therewith.

75. The sound absorbing laminate of Claim 73, wherein the substrate comprises thermoformable fibrous material.

76. The sound absorbing laminate of Claim 73, wherein the polyurethane comprises a filler selected from the group consisting of calcium carbonate, calcium hydroxide, aluminum trihydrate, talc, bentonite, barytes, 5 silica, clay and mica.

77. The sound absorbing laminate of Claim 73, wherein the article is a vehicle firewall and the sound absorbing laminate is a dashboard insulator.

78. The sound absorbing laminate of Claim 73, wherein the article is a vehicle floor and the sound absorbing laminate is a floor covering.

79. The sound absorbing laminate of Claim 73, wherein the article is a vehicle panel and the sound absorbing laminate is a vehicle interior trim component.

80. The sound absorbing laminate of Claim 73, wherein the polyurethane has a non-constant thickness on the substrate.

81. The sound absorbing laminate of Claim 73, wherein the substrate has one or more recessed portions formed therein, and wherein polyurethane is disposed within the one or more recessed portions.

82. The sound absorbing laminate of Claim 73, wherein the substrate comprises a secondary article integrally formed therewithin and further comprising polyurethane applied to the substrate at one or more areas adjacent the secondary article.

83. A vehicle, comprising:  
a panel; and  
a sound absorbing laminate attached to the panel, wherein the sound absorbing laminate comprises:  
a substrate in the shape of the panel,  
wherein the substrate comprises opposite first and second surfaces, and wherein the substrate first surface is configured to be attached to the panel in face-to-face relationship therewith; and  
a layer of breathable polyurethane on the substrate second surface, wherein the polyurethane is configured to enhance sound absorption characteristics.

84. The vehicle of Claim 83 further comprising upholstery material attached to the polyurethane layer in face-to-face contacting relationship therewith.

85. The vehicle of Claim 83, wherein the substrate comprises thermoformable fibrous material.

86. The vehicle of Claim 83 wherein the polyurethane comprises a filler selected from the group consisting of calcium carbonate, calcium hydroxide,

5 aluminum trihydrate, talc, bentonite, barytes, silica,  
clay and mica.

87. The vehicle of Claim 83, wherein the panel is a firewall and the sound absorbing laminate is a dashboard insulator.

88. The vehicle of Claim 83, wherein the panel is a vehicle floor and the sound absorbing laminate is a floor covering.

89. The vehicle of Claim 83, wherein the polyurethane has a non-constant thickness on the substrate.

90. The vehicle of Claim 83, wherein the substrate has one or more recessed portions formed therein, and wherein polyurethane is disposed within the one or more recessed portions.

5 91. The vehicle of Claim 83, wherein the substrate comprises a secondary article integrally formed therewithin and further comprising polyurethane applied to the substrate at one or more areas adjacent the secondary article.

92. A method of producing a carpet assembly for use in vehicles, comprising:

5 providing a substrate having opposite first and second surfaces; wherein the substrate first surface is configured to be attached to a vehicle panel in contacting face-to-face relationship therewith, and wherein the substrate has elastic memory such that the substrate is unable to maintain an unassisted non-flat configuration;

10 applying a layer of uncured, breathable

polyurethane onto the substrate second surface such that the substrate becomes moldable;

attaching a porous carpet layer to the substrate, wherein the carpet layer comprises a backing, and wherein the backing is in contacting face-to-face relationship with the breathable polyurethane layer;

forming the carpet layer and substrate into a desired shape; and

subjecting the breathable polyurethane layer to conditions sufficient to cure breathable polyurethane layer such that the substrate and carpet layer are bonded together to form a porous, breathable carpet assembly having the desired shape.

93. The method of Claim 92, wherein applying a layer of uncured, breathable polyurethane onto the substrate second surface comprises spraying uncured, breathable polyurethane onto the substrate second surface.

94. The method of Claim 92, wherein the substrate comprises thermoformable fibrous material selected from the group consisting of natural fibers, man-made fibers, and blends of natural fiber and man-made fibers.

95. The method of Claim 92, further comprising applying additional breathable polyurethane on one or more selected portions of the substrate first surface to enhance sound absorption characteristics of the carpet assembly.

96. The method of Claim 92, further comprising applying polyurethane on one or more selected portions of the substrate first surface, wherein the polyurethane is non-porous and is configured to enhance sound attenuation

5 characteristics of the carpet assembly.

97. A porous, breathable carpet assembly for use in vehicles, comprising:

a substrate having opposite first and second surfaces, wherein the substrate first surface is  
5 configured to be attached to a vehicle panel in contacting face-to-face relationship therewith, and wherein the substrate has elastic memory such that the substrate is unable to maintain an unassisted non-flat configuration; and

10 a porous carpet layer adhesively secured to the substrate via a breathable polyurethane layer, wherein the carpet layer comprises a backing, and wherein the backing is in contacting face-to-face relationship with the breathable polyurethane layer.

98. The porous, breathable carpet assembly of Claim 97, wherein the substrate comprises thermoformable fibrous material selected from the group consisting of natural fibers, man-made fibers, and blends of natural  
5 fiber and man-made fibers.

99. The porous, breathable carpet assembly of Claim 97, further comprising additional breathable polyurethane on one or more selected portions of the substrate first surface, wherein the additional  
5 breathable polyurethane enhances sound absorption characteristics of the carpet assembly.

100. The porous, breathable carpet assembly of Claim 97, further comprising additional polyurethane on one or more selected portions of the substrate first surface, wherein the additional polyurethane is non-  
5 porous and is configured to enhance sound attenuation characteristics of the carpet assembly.

101. The porous, breathable carpet assembly of Claim 97, wherein the substrate first surface has one or more recessed portions formed therein, and further comprising polyurethane applied within the one or more recessed portions.

5

102. A vehicle, comprising:  
a floor panel; and  
a porous, breathable carpet assembly attached to the floor panel, wherein the porous, breathable carpet assembly comprises:

5

a substrate having opposite first and second surfaces, wherein the substrate first surface is configured to be attached to a vehicle panel in contacting face-to-face relationship therewith, and wherein the substrate has elastic memory such that the substrate is unable to maintain an unassisted non-flat configuration; and

10

a porous carpet layer adhesively secured to the substrate via a breathable polyurethane layer, wherein the carpet layer comprises a backing, and wherein the backing is in contacting face-to-face relationship with the breathable polyurethane layer.

15

103. The vehicle of Claim 102, wherein the substrate comprises thermoformable fibrous material selected from the group consisting of natural fibers, man-made fibers, and blends of natural fiber and man-made fibers.

5

104. The vehicle of Claim 102, further comprising additional breathable polyurethane on one or more selected portions of the substrate first surface, wherein the additional breathable polyurethane enhances

5 sound absorption characteristics of the carpet assembly.

105. The vehicle of Claim 102, further comprising additional polyurethane on one or more selected portions of the substrate first surface, wherein the additional polyurethane is non-porous and is  
5 configured to enhance sound attenuation characteristics of the carpet assembly.

106. The vehicle of Claim 102, wherein the substrate first surface has one or more recessed portions formed therein, and further comprising polyurethane applied within the one or more recessed portions.

1/7

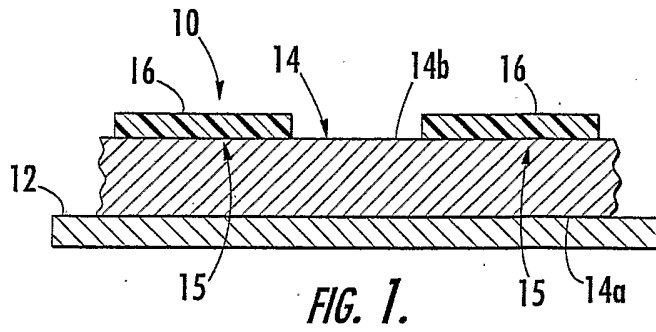

FIG. 1.

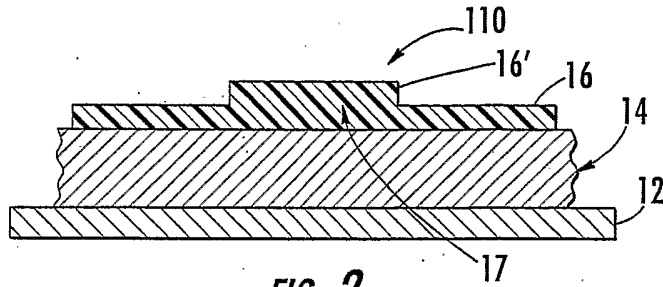

FIG. 2.

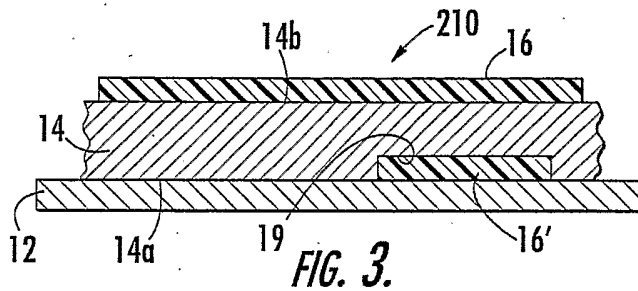

FIG. 3.

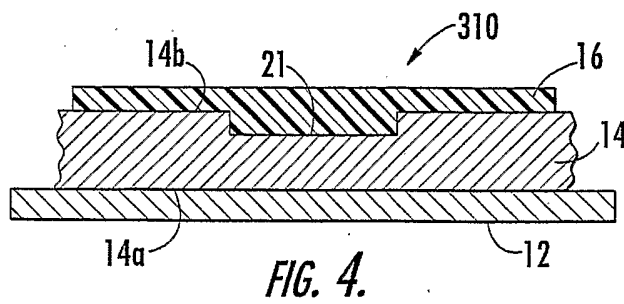

FIG. 4.

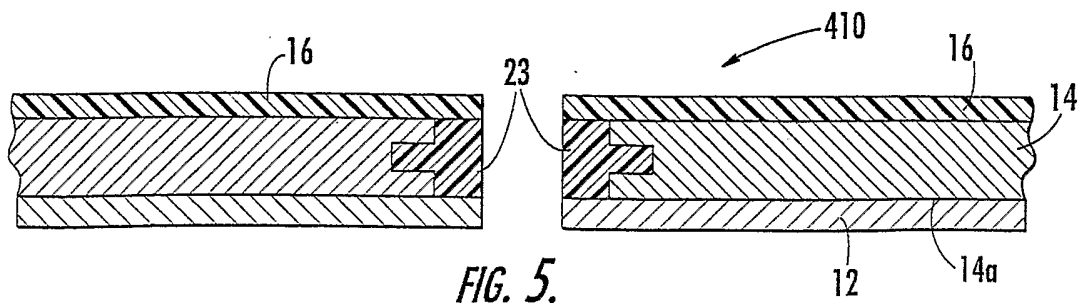

FIG. 5.

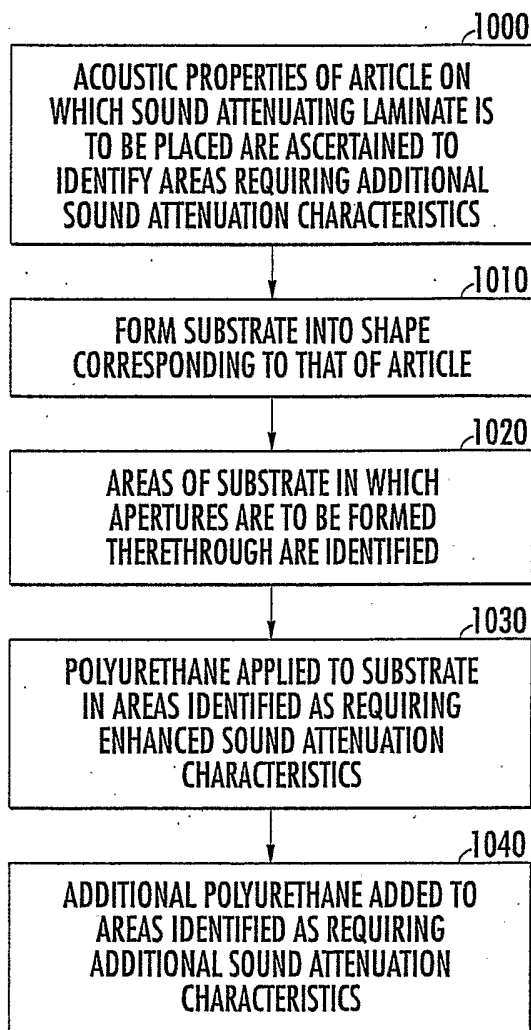

FIG. 6.

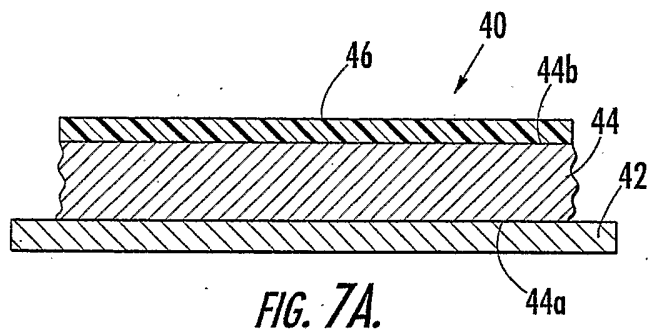

FIG. 7A.

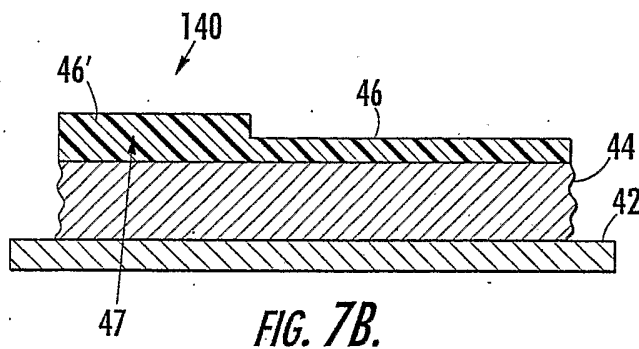

FIG. 7B.

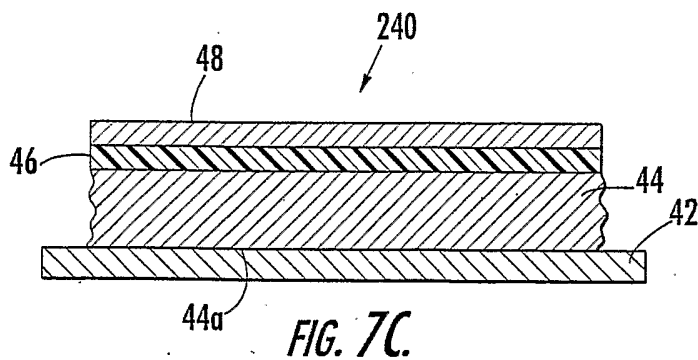

FIG. 7C.

4/7

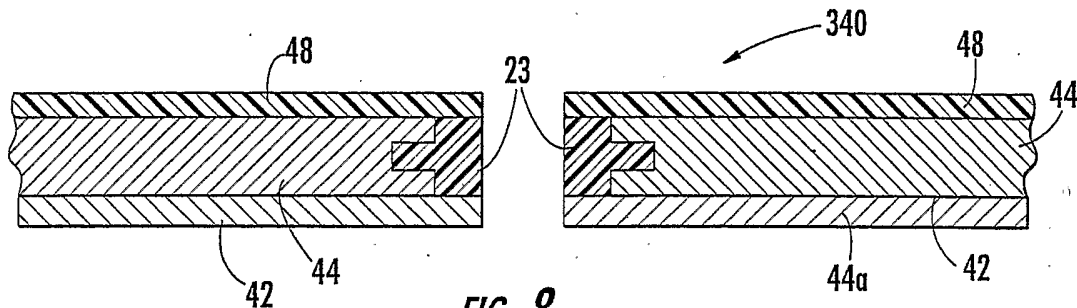

FIG. 8.

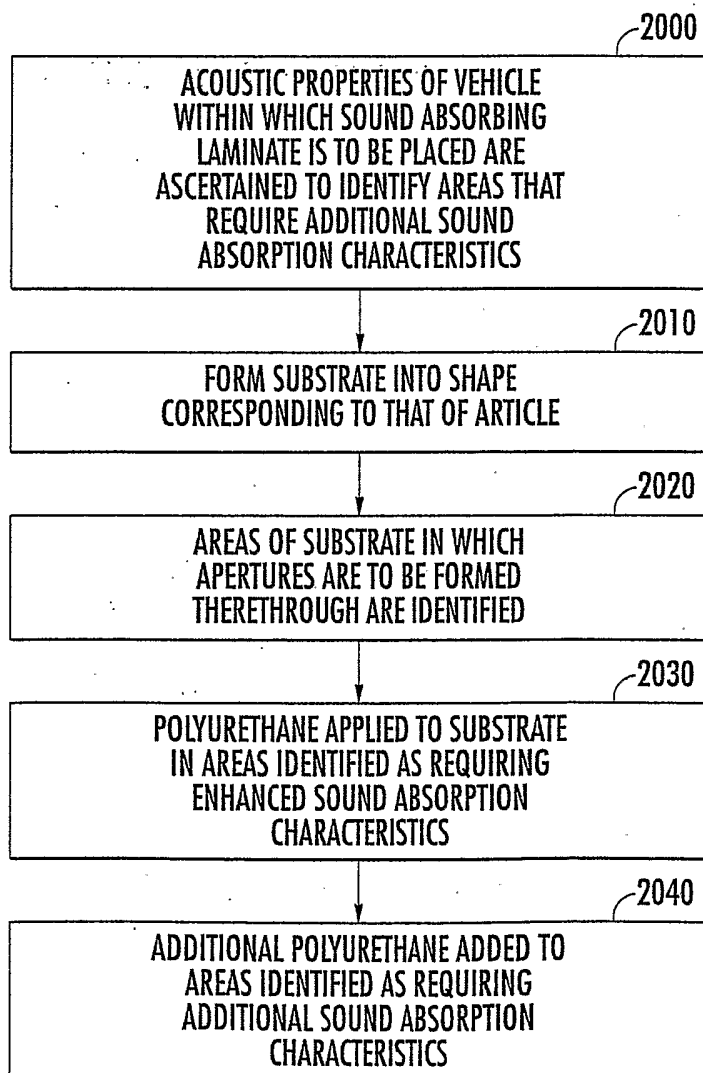
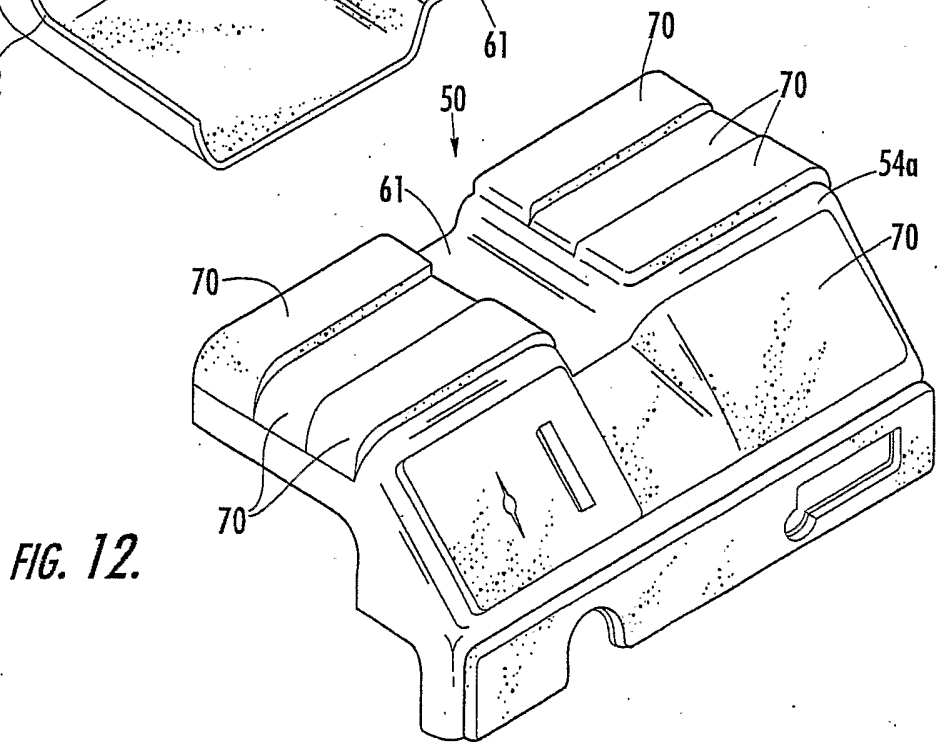
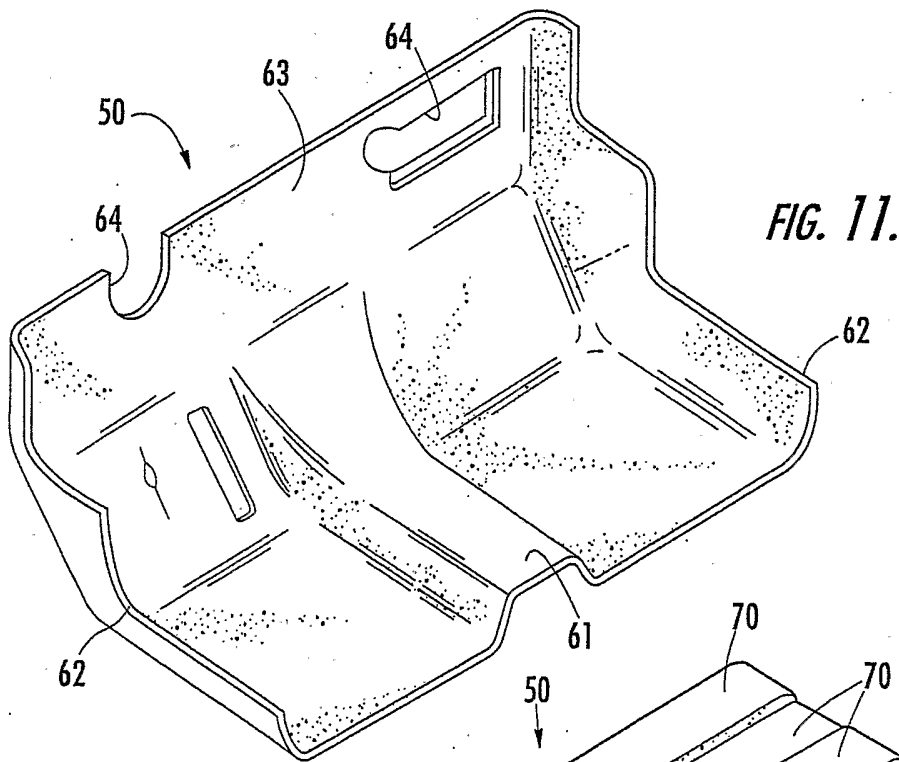
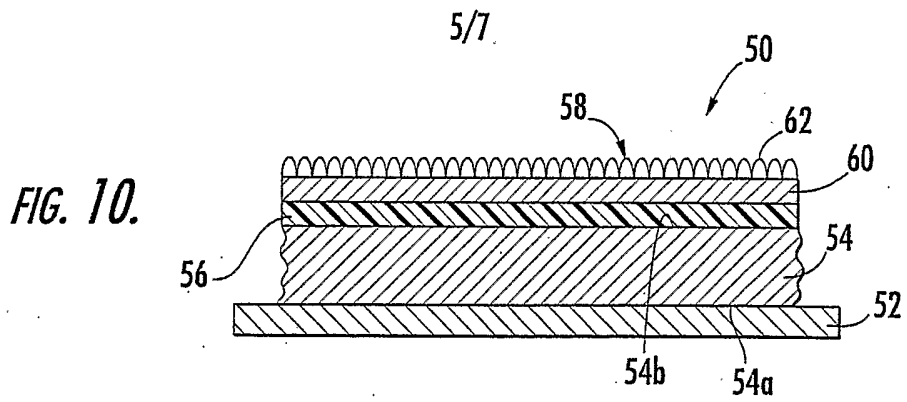
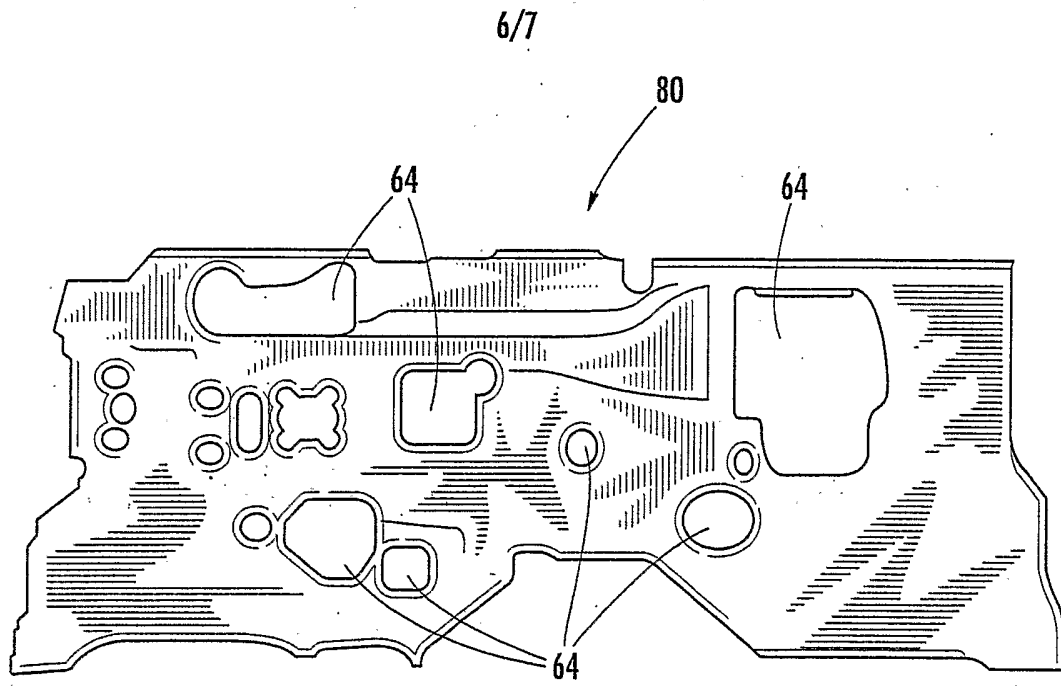

FIG. 9.





*FIG. 13.*

7/7

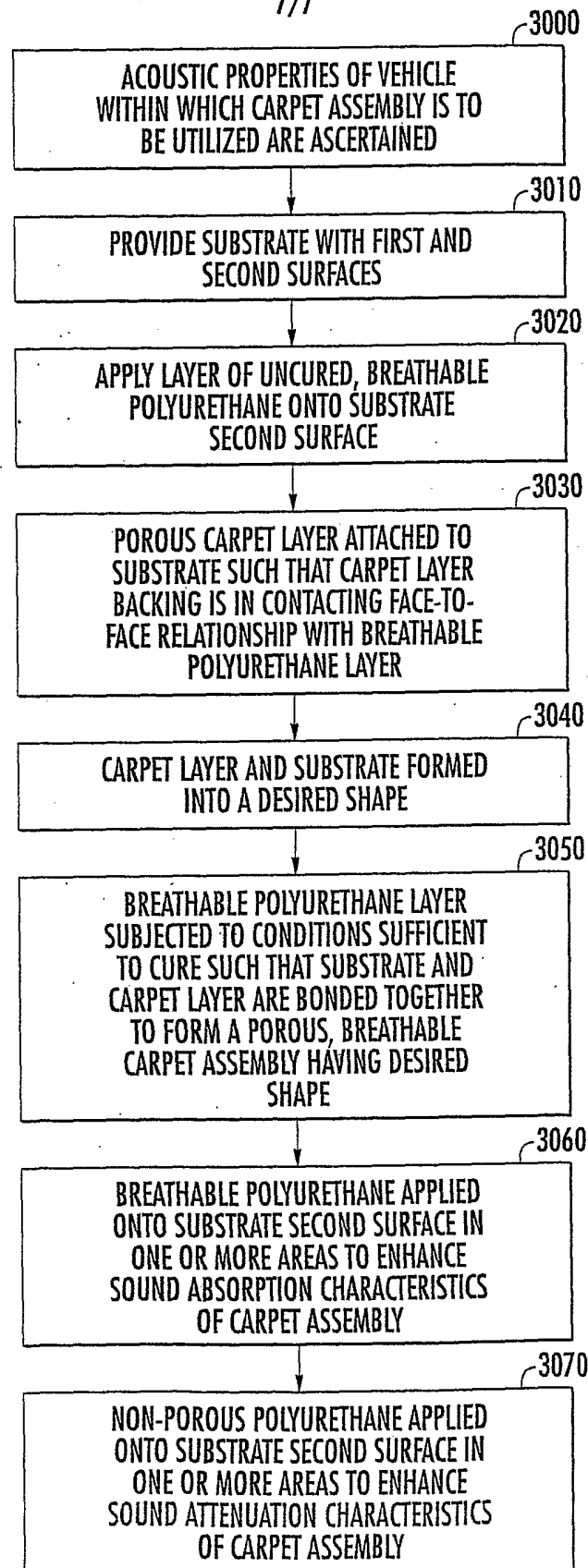

FIG. 14.

## INTERNATIONAL SEARCH REPORT

International application No.  
PCT/US02/35819**A. CLASSIFICATION OF SUBJECT MATTER**

IPC(7) :B32B 3/02, 33/00, 27/04, 27/12

US CL :442/120; 428/85, 96

According to International Patent Classification (IPC) or to both national classification and IPC

**B. FIELDS SEARCHED**

Minimum documentation searched (classification system followed by classification symbols)

U.S. : 442/120; 428/85, 96

Documentation searched other than minimum documentation to the extent that such documents are included in the fields searched

Electronic data base consulted during the international search (name of data base and, where practicable, search terms used)

**C. DOCUMENTS CONSIDERED TO BE RELEVANT**

Category*	Citation of document, with indication, where appropriate, of the relevant passages	Relevant to claim No.
A,P	US 6,335,379 B1 (LEENSLAG et al) 01 January 2002, see entire document	1-106
A	US 5,942,321 A (ROMESBERG et al) 24 August 1999, see entire document.	1-106
A	US 5,082,716 A (SATTERFIELD et al) 21 January 1992, see entire document.	1-106

 Further documents are listed in the continuation of Box C.
  See patent family annex.

* Special categories of cited documents:	"T"	later document published after the international filing date or priority date and not in conflict with the application but cited to understand the principle or theory underlying the invention
"A" document defining the general state of the art which is not considered to be of particular relevance	"X"	document of particular relevance; the claimed invention cannot be considered novel or cannot be considered to involve an inventive step when the document is taken alone
"E" earlier document published on or after the international filing date	"Y"	document of particular relevance; the claimed invention cannot be considered to involve an inventive step when the document is combined with one or more other such documents, such combination being obvious to a person skilled in the art
"L" document which may throw doubts on priority claim(s) or which is cited to establish the publication date of another citation or other special reason (as specified)	"&"	document member of the same patent family
"O" document referring to an oral disclosure, use, exhibition or other means		
"P" document published prior to the international filing date but later than the priority date claimed		

Date of the actual completion of the international search

16 DECEMBER 2002

Date of mailing of the international search report

14 JAN 2003

Name and mailing address of the ISA/US  
Commissioner of Patents and Trademarks  
Box PCT  
Washington, D.C. 20231

Facsimile No. (703) 305-3230

Authorized officer

CHRISTOPHER C. PRATT

Telephone No. (703) 305-3257