

E. E. BROCK.
ORGAN.

No. 523,322.

Patented July 24, 1894.

Fig. 1.

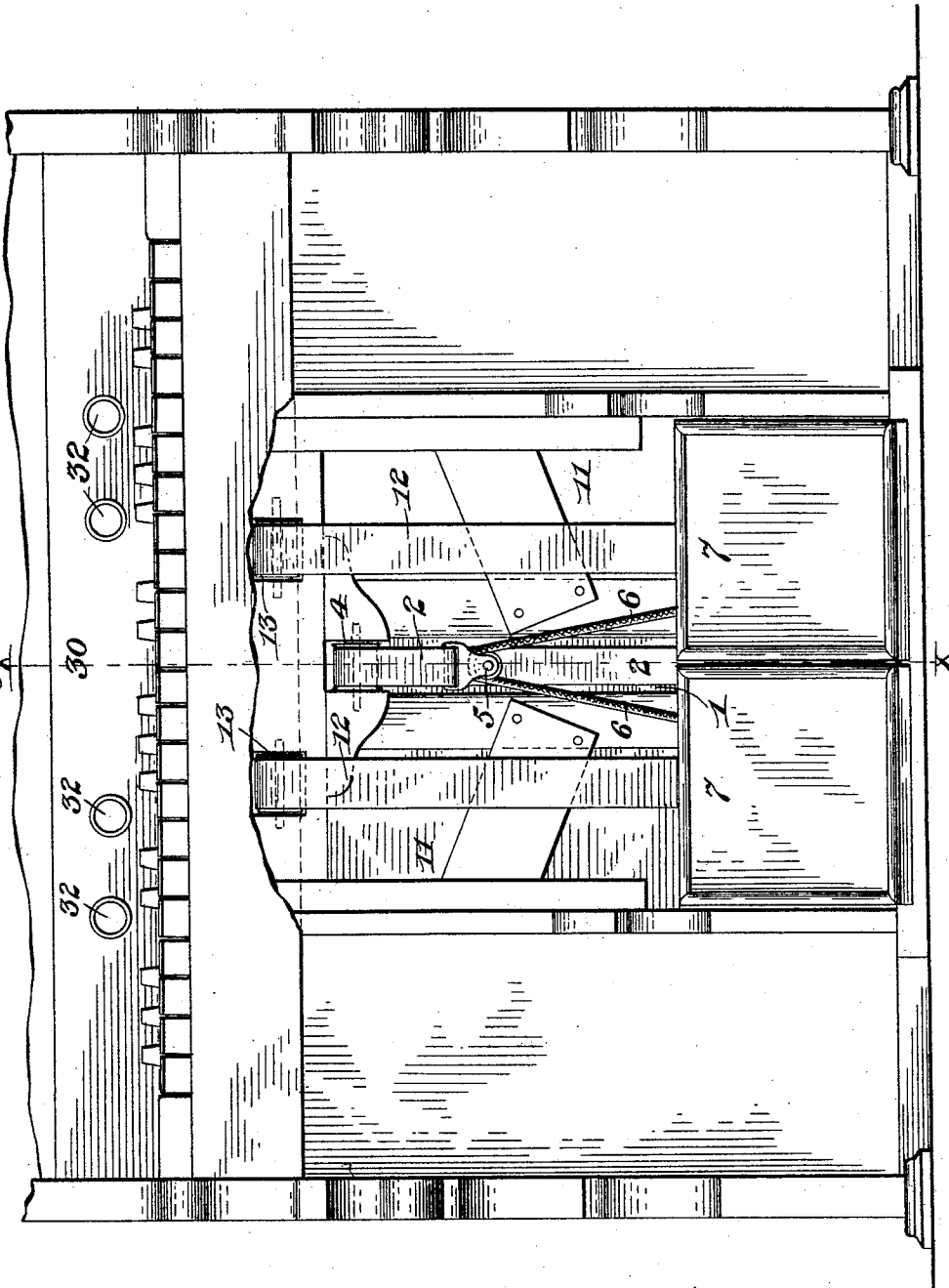

Witnesses

A. Leverance
W. Harvey Muzzey

Inventor

Edward E. Brock,
By *J. B. Lawyer*
Attorney

E. E. BROCK.
ORGAN.

No. 523,322.

Patented July 24, 1894.

Fig. 2.

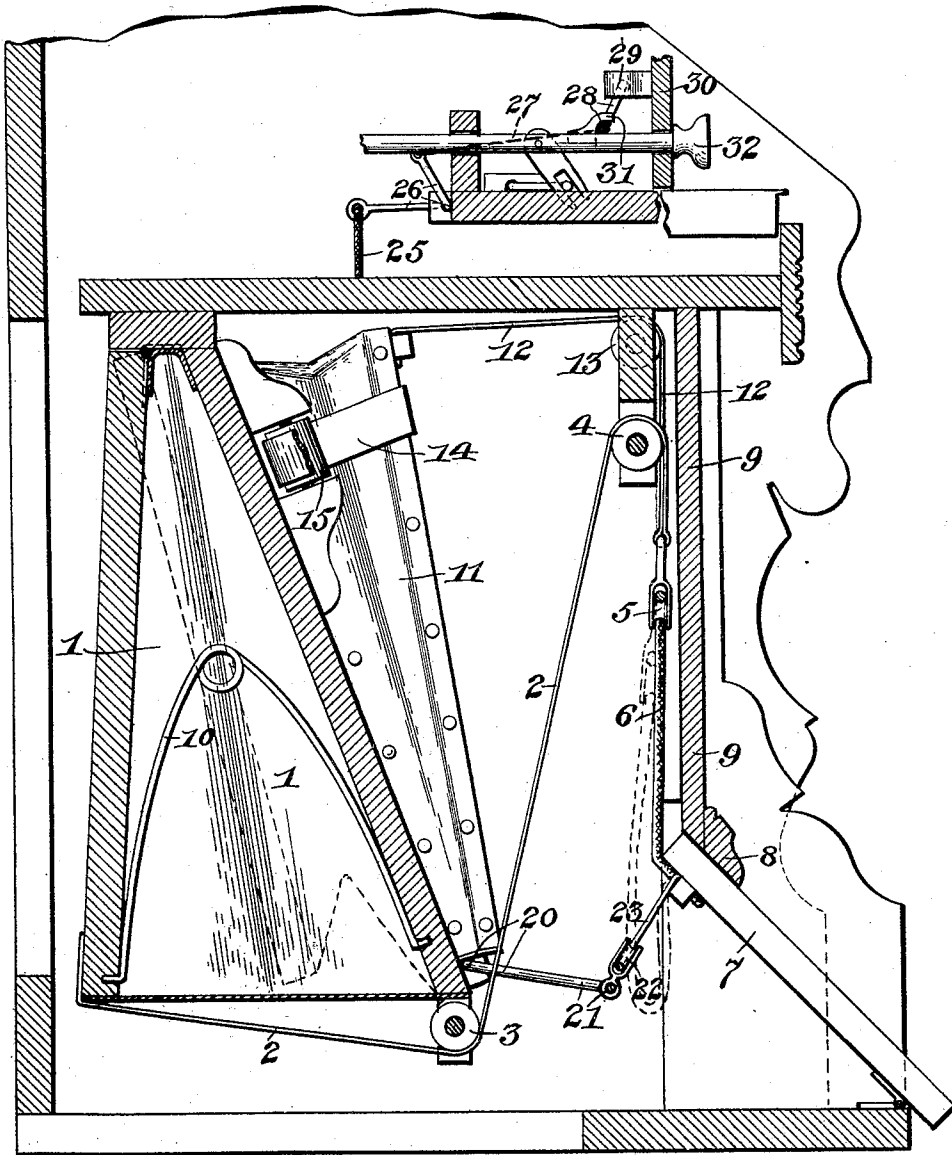

Witnesses

Everance
W. Harvey Muzzey

Inventor

Edward C. Brock,
By *J. B. Lawyer,*
Attorney

E. E. BROCK.
ORGAN.

No. 523,322.

Patented July 24, 1894.

Fig. 3.

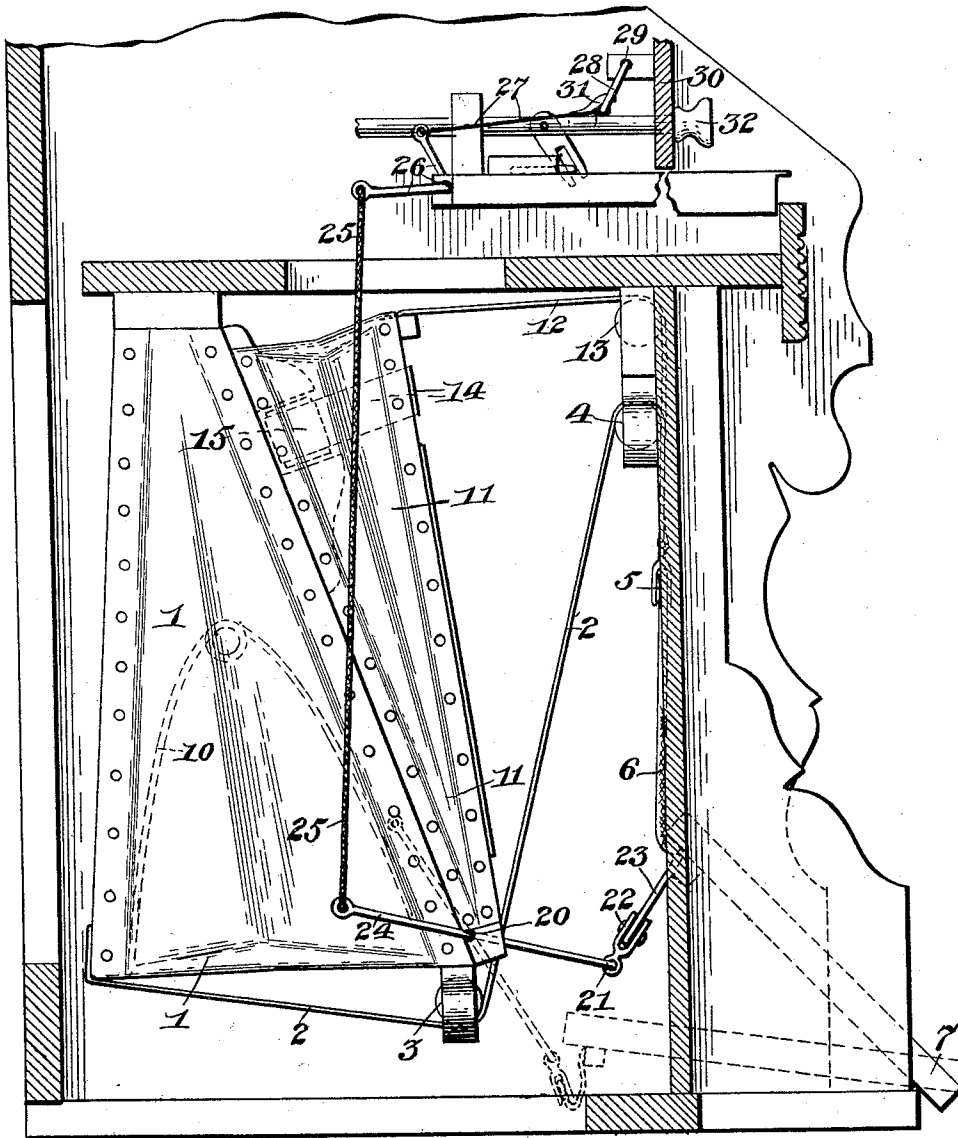

Witnesses

A. Everance
W. Harry Muzzy

Inventor

Edward E. Brock,

By *J. B. Lawyer*
Attorney

E. E. BROCK.
ORGAN.

No. 523,322.

Patented July 24, 1894.

Fig. 4.

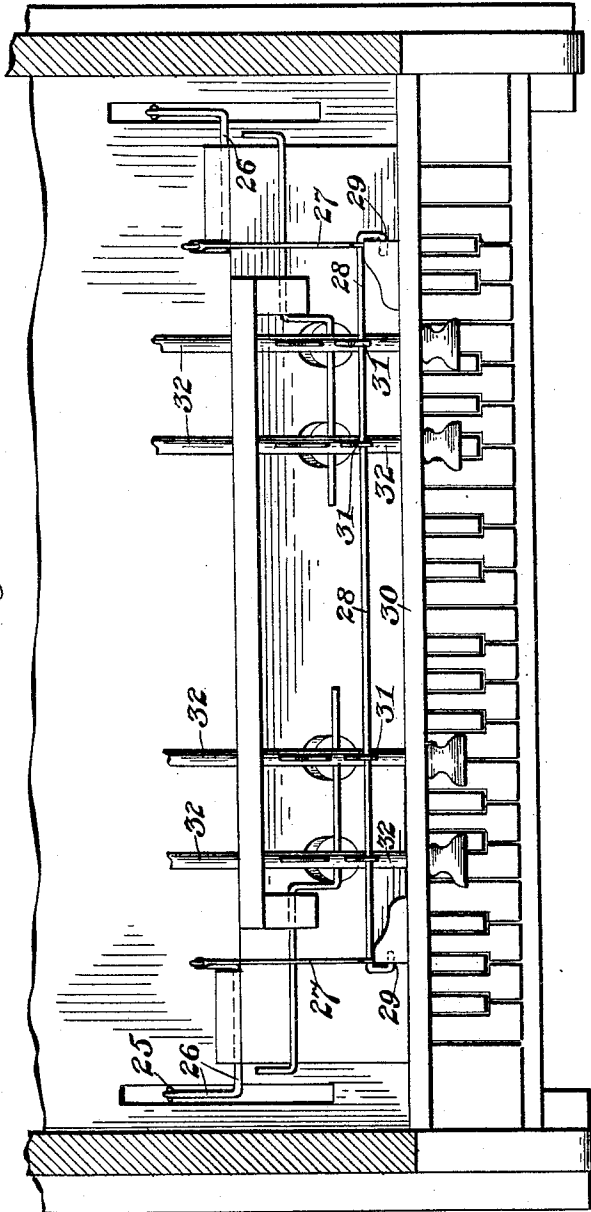
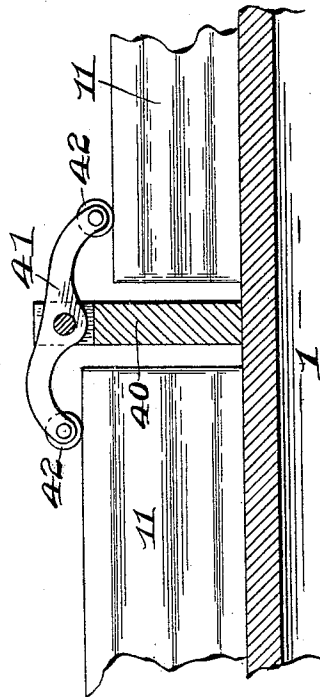

Fig. 5.



Witnesses

Everance
W. Harry Muff

Inventor

Edward E. Brock

By *J. B. Lawyer*
Attorney

UNITED STATES PATENT OFFICE.

EDWARD E. BROCK, OF BENTONVILLE, ARKANSAS, ASSIGNOR OF ONE-HALF
TO JOHN K. PARTMAN, OF SAME PLACE.

ORGAN.

SPECIFICATION forming part of Letters Patent No. 523,322, dated July 24, 1894.

Application filed April 9, 1894. Serial No. 506,923. (No model.)

To all whom it may concern:

Be it known that I, EDWARD E. BROCK, a citizen of the United States, residing at Bentonville, in the county of Benton and State of Arkansas, have invented certain new and useful Improvements in Organs; and I do declare the following to be a full, clear, and exact description of the invention, such as will enable others skilled in the art to which it appertains to make and use the same, reference being had to the accompanying drawings, and to the figures of reference marked thereon, which form a part of this specification.

My invention relates to certain new and useful improvements in reed organs, it having for its object to provide a construction whereby the pedal opening will be normally kept closed, preventing the entrance of dust or noxious animals; whereby a constant exhaustion of air from the reservoir may be obtained without the use of springs to collapse the bellows, and whereby the mouth of the reeds will be automatically closed upon the release of the pedals, and it also consists in the construction, arrangement and combination of the several parts as will be hereinafter more fully described and claimed.

The first object of my invention, namely, the closing of the pedal opening I accomplish by securing to the back of the large bellows or reservoir a strap, which, after passing over properly located guides or pulleys, is brought down from the upper part of the front of the organ case and is secured to the pedals, preferably, by an elastic cord or webbing, the central portion of which passes over a pulley secured on the forward end of the strap, the opposite ends of the said cord or webbing being secured to the opposite pedals. The length of the connection thus formed between the pedals and the movable back of the reservoir by means of the strap and webbing is such that when the reservoir is expanded and the elastic webbing contracted that the pedals will be held up against the front panel of the organ case. While, when the reservoir is collapsed, as is the case when in use, the connection before mentioned hangs loose and permits the ready movements of the pedals.

I accomplish the second object of my invention by securing the opposite ends of a

strap to the movable fronts of oppositely arranged bellows, the central portion of the said strap being carried to the rear and around a suitable guide or roller. Thus, when the front of either bellows is drawn forwardly by the movement of the corresponding pedal, the front of the opposite bellows will be drawn rearwardly by the said strap, whereby the pedal corresponding to the last named bellows will be raised, ready to be depressed in turn, raising the first named pedal.

The third object of my invention, namely, the automatic closing of the mouths of the reeds I accomplish by securing to each one end of a cord or chain, the central portion of which is carried downwardly, and passed around a pulley mounted on a crank shaft, the said lever being connected with a rocking rod mounted in the reed case immediately above the stop action, with all or any of the stops of which it engages. Thus, upon depressing one of the pedals, whereby the other pedal will be raised (when the reservoir is collapsed or in case the said pedals are not connected with the reservoir) the cord or chain will pass freely around the pulley without altering or changing the position thereof or of the crank shaft upon which it is carried. Upon the pedals rising to the position which they normally have, and in which they close the pedal opening, as hereinbefore described, the pulley, and with it, the crank of the shaft will be raised, drawing back the rocking rod and moving the stops, whereby the mouths of the reeds or reed cells will be closed, as is now the case when the several stops are pushed in by hand.

Referring to the accompanying drawings in which corresponding parts are designated by similar marks of reference: Figure 1 is a front elevation of an organ having my improvements applied thereto, the front panel and a part of the stop board being removed for the purpose of better illustrations. Figure 2 is a central vertical section taken on line X—X of Fig. 1, the front panel being shown in place. Fig. 3 is an end elevation of the invention shown in Fig. 1, the end of the organ case being removed. Fig. 4 is a plan view with the cover removed. Fig. 5 is a detail view showing a modified form of mechanism

for connecting the two bellows to cause them to work alternately.

The reservoir or main bellows 1 is of the usual construction and is secured within the base of the casing of the organ, and has secured to the bottom portion of its movable back a strap 2 of any suitable material, the said strap passing over a roller 3 mounted upon the bottom of the front of the said reservoir, and passing upwardly and over a roller 4, mounted in suitable bearings in the forward portion of the organ case, below the key-board. To the forward end of the strap 2, which depends from the said roller 4, is secured a pulley 5, over which pulley the central portion of an elastic cord or web 6 passes, each end of the said web being connected to the rear and upper edge of one of the pedals 7, the forward and lower edges of the said pedals being hinged to the bottom of the case of the organ. The combined length of the strap 2 and the cord or webbing 6 is such that when the reservoir 1 is expanded and its back moved to the rear to its full extent, and the cord 6 contracted, the upper and rear edges of the pedals 7 will be drawn up tightly against the incline flange 8, provided to receive them on the bottom of the front panel 9, thus making a dust and insect proof joint at this point. By this means the pedals will be retained when the organ is not in use in the above described position, and will be automatically moved into that position upon the stopping of the movement of the pedals by the expansion of the reservoir caused by the springs 10, provided for that purpose, as is well known in the art. The use of the elastic cord 6 is to permit the initial depression of the pedals to actuate the auxiliary bellows without moving the rear or back of the reservoir, which as before stated is normally in its expanded position, and retained therein by the aforesaid springs 10, the cord expanding to permit this result.

The auxiliary bellows or bellows proper 11 are two in number, one of them being mounted on the front of the reservoir on each side of its medial line. A belt 12 leads from the rear and upper edge of each pedal over a roller 13 mounted in the forward portion of the case below the key-board to the front leaf of the corresponding bellows. A strap 14 has its opposite ends connected to the adjacent edges of the said bellows, and has its central portion passed around a roller 15 secured on the front of the reservoir, between the said bellows 11. Thus by depressing one pedal and moving the leaf of the corresponding bellows forwardly, the leaf of the opposite bellows will be drawn to the rear, and the pedal corresponding thereto will be raised, while upon depressing the last named pedal, the reverse will be the case.

It will thus be seen that the pedals must be alternately depressed, the one rising upon the depression of the other, and that while one bellows is expanding, the opposite bellows is

collapsing, thereby producing a uniform exhaust from the reservoir, and producing a uniformity in tone.

The auxiliary bellows are connected with the reservoir and are provided with inlet and outlet valves in the manner well known in the art, and these form no part of this invention.

It will be noticed that by connecting the auxiliary bellows together in the manner before explained the use of springs to collapse the bellows is rendered unnecessary, thus doing away with the part which frequently breaks when in use and reducing by a large amount the force or labor of pumping.

A crank shaft 20 is suitably mounted on the lower portion of the front of the reservoir, the central crank portion 21 thereof projecting forwardly, and carrying a pulley 22, while the ends of the said shaft are bent rearwardly on each side of the said reservoir. A flexible cord or chain 23 has its opposite ends secured to the rearward and upper portions of the pedals, the central portion thereof passing under and around the pulley 22.

It will be seen that upon depressing either of the pedals, whereby the other pedal will be raised, that no motion will be imparted to the crank 21, the cord simply moving around the pulley. This is true only when the pedals are in the slightly depressed position which they are free to assume upon the collapse of the reservoir or upon the expansion of the elastic cord or web 6, for when both the pedals are drawn up against the flange 8 by the expansion of the reservoir, as has been hereinbefore explained, the pulley and crank carrying it, will be raised, whereby the shaft 20 will be partially turned in its bearings, and its arms 24 depressed. Each of these arms 24 is connected by a rod 25 with one end of a double crank lever 26, the opposite end or crank of the said lever being connected by the link 27 with the one end of the rocking rod 28, which is pivoted in bearings 29 on the rear of the stop board 30, although it is obvious that if desired, only one end of the shaft 20 need be provided with the arm 24, and that only one crank lever need be used.

The stop action may be of any approved construction, and each of the stops 32 is provided with a lug 31, in front of which rests the rocking rod 28. This rod is normally in its rearward position, and bears against the forward faces of the lugs 31, it being held in the position just named by the pedals, which, as before stated, are normally at the extreme limit of their upward movement. However, when the pedals have been depressed by the weight of the feet of the operator upon them, before the movement of the bellows has commenced, the crank 21 of the shaft 20 will be lowered sufficiently to raise the arms 24 thereof to an extent sufficient to permit the forward movement of the rocking rod by the operator in moving or pulling outwardly any or all of the stops, and the rocking rod will remain in this position as long as the pedals

are moved or as long as the weight of the feet of the operator retain the pedals or one of them in a slightly depressed condition, in which position the reservoir may be collapsed, and the cord 6 contracted, or the reservoir may be expanded and the cord extended.

When the operator by removing his feet from off the pedals permits the latter to be drawn to the limit of their upward motion by means of the expansion of the bellows, as hereinbefore described, the crank 21, and pulley 22 thereon, will be raised by means of the flexible cord or chain 23, and at the same time the rearwardly extending arm or arms 24 of the shaft will be depressed, moving the crank lever or levers 26 and drawing the rocking rod 28 rearwardly, which by bearing upon the lugs 31 on the stops 32, will draw the latter in and close the mouths of the reeds or reed cells, as is now the case when the stops are pushed in by hand.

As in practice the expansion of the reservoir will not take place until a minute or more after the motion of the pedals has ceased, no inconvenience will result by the automatic closing of the mouths of the cells in the manner just explained, upon a temporary or occasional cessation of the movement of the pedals, but on the contrary the cells will not be closed until the vacuum within the instrument has so far disappeared as to cease to cause sound.

In lieu of using the strap 14, as hereinbefore described, to cause the alternate motion of the opposite bellows, I may, if I so desire, use the construction shown in Fig. 5, in which a bracket 40 is secured to the front of the reservoir between the bellows, and projecting forwardly therefrom carries in its forward end a pivoted lever 41, the opposite ends or arms of which are provided with rollers 42, which work upon the movable leaves of the opposite bellows. It will be seen that by this construction the same result will be obtained as by the use of the strap 14, and this without departing from the spirit of my invention.

Having thus described my invention, what I claim, and desire to secure by Letters Patent of the United States, is—

1. In an organ, the combination with the expansible reservoir and pedals thereof, of an elastic connection between the said reservoir and pedals, whereby upon an expansion of the said reservoir the pedals are drawn against the top of the pedal opening, substantially as described.

2. In an organ, the combination, with the expansible reservoir and pedals thereof, of a strap secured to the movable leaf of the said reservoir and being brought down from the front of the organ case, a pulley mounted on the front end of the said strap, and an elastic cord having its opposite ends secured to the opposite pedals and having its central portion passing over the said pulley, substantially as described.

3. In an organ, the combination with bel-

lows, and with pedals for expanding the said bellows, of a connection between the movable leaves of the opposite bellows, whereby they are caused to move in opposite directions, a reservoir, and an elastical connection between the said reservoir and pedals, whereby upon an expansion of the said reservoir the pedals are drawn against the top of the pedal opening, substantially as described.

4. In an organ, the combination, with a plurality of bellows, and with mechanism for imparting motion to the movable members thereof, of a roller located behind and between the movable members of the said bellows, and a flexible connection passing over the said roller, and having its opposite ends secured to the movable members of the opposite bellows, substantially as described.

5. In an organ, the combination, with the stop action and with pedals for producing the air current, of mechanism connecting the pedals and stop action, whereby the reed cells will be closed by the rising of the pedals, substantially as described.

6. In an organ, the combination, with the stop action, and with pedals for producing the air current, of a crank, a flexible connection having its central portion movably connected with the said crank, and its ends connected with the pedals, and mechanism connecting the said crank and stop action, whereby the latter will be thrown in upon the rising of both pedals, substantially as described.

7. In an organ, the combination with the stops of the stop action, having lugs thereon, and with the pedals for producing the air current, of a rocking rod adapted to bear against the lugs upon the said stop, a crank having a pulley thereon, a flexible connection having its opposite ends secured to the opposite pedal, and its central portion passing around the said pulley, and a connection between the said crank and rocking rod, whereby the stops will be thrown in upon the rising of both pedals, substantially as described.

8. In an organ, the combination, with the stops of the stop action, with the pedals for producing the air current, and with an expansible reservoir, of a connection between the movable member of the said reservoir and the said pedals, whereby upon an expansion of the said reservoir the latter will be raised, a crank, a flexible cord having its opposite ends secured to the said pedal, and its central portion movably connected with the said crank, a rocking rod adapted to engage the stops of the stop action to close the reed cells, and a connection between the said crank and rocking rod, whereby the reed cells will be closed upon the rising of both pedals, substantially as described.

In testimony whereof I affix my signature in presence of two witnesses.

EDWARD E. BROCK.

Witnesses:

VERNON M. DORSEY,
J. B. LAWYER.