

(No Model.)

2 Sheets—Sheet 1.

C. K. LONGENECKER.
STEAM ENGINE GOVERNOR.

No. 457,322.

Patented Aug. 4, 1891.

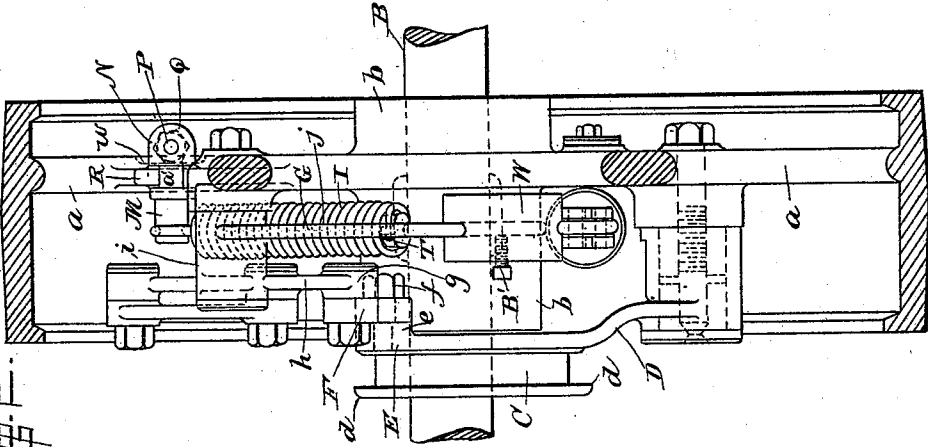

7747

7747

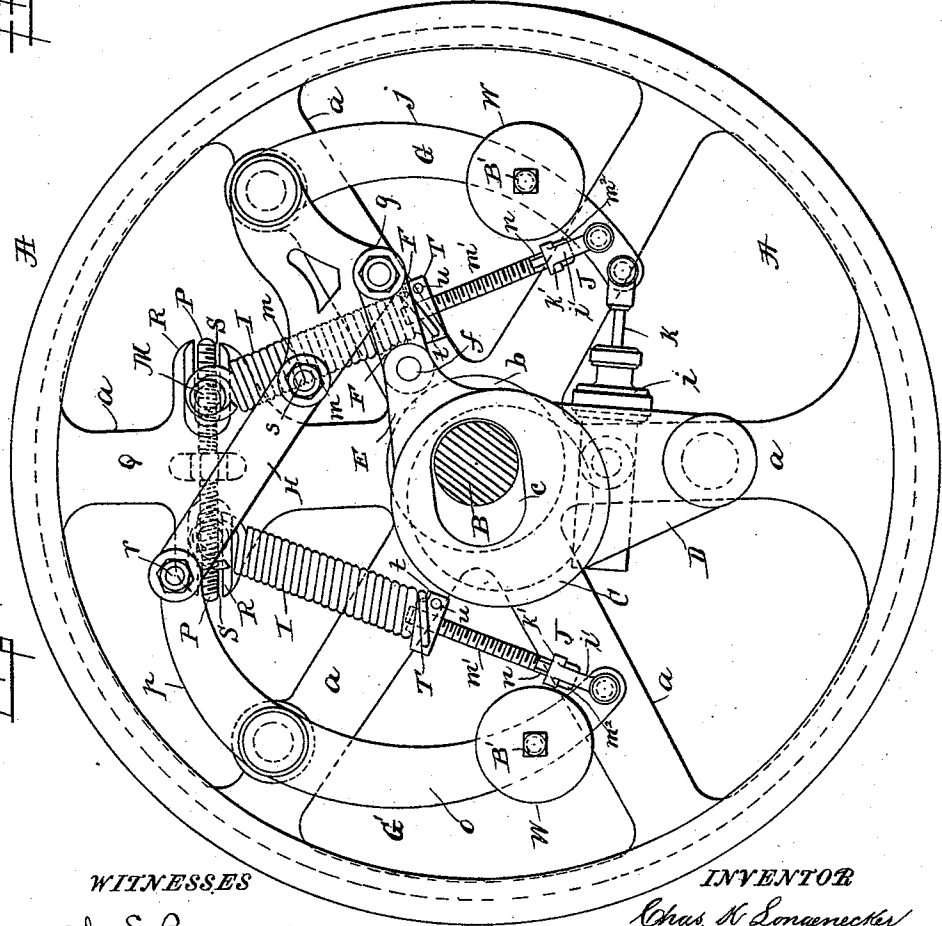

WITNESSES

H. E. Bowen
G. M. Coppenhaver

INVENTOR

Chas. K. Longenecker
by W. A. Redwood Attorney

C. K. LONGENECKER.
STEAM ENGINE GOVERNOR.

No. 457,322.

Patented Aug. 4, 1891.

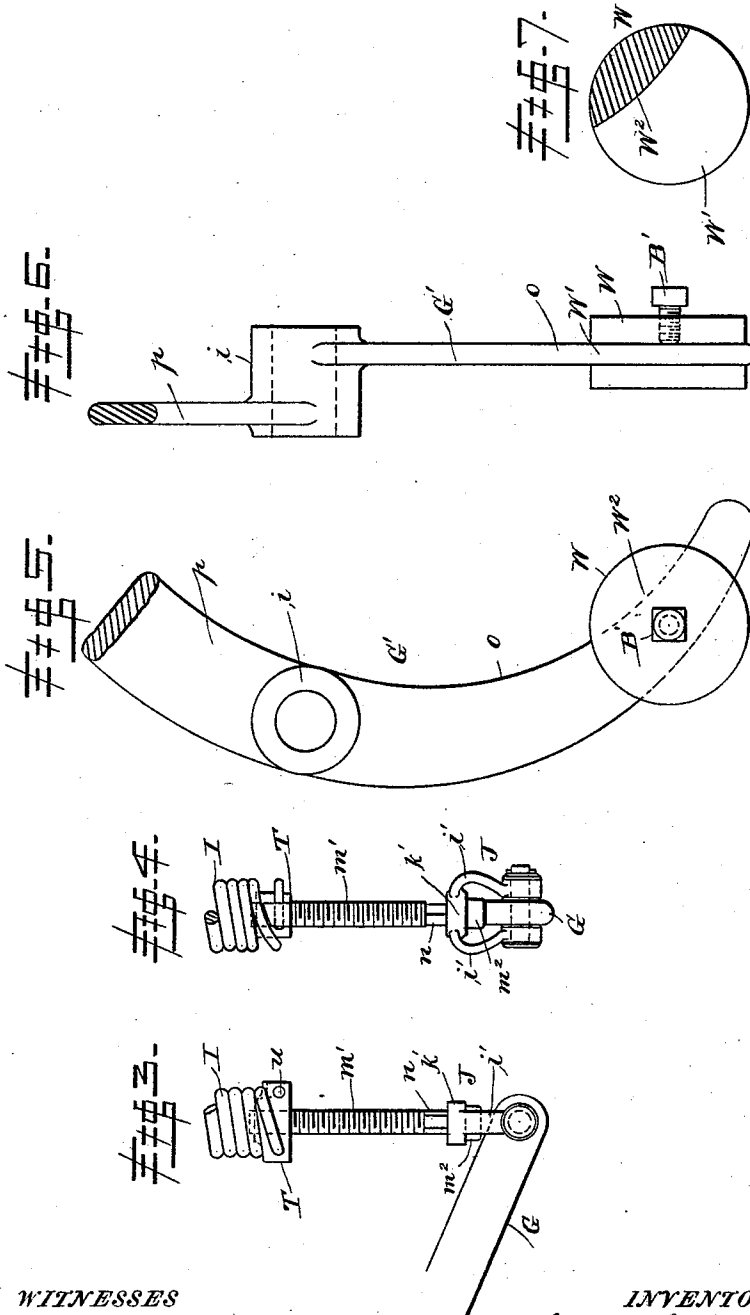

WITNESSES
H. E. Bomen
J. M. Coppenhafer,

INVENTOR
Chas. K. Longenecker,
 by *W. A. Redmond*
 Attorney

UNITED STATES PATENT OFFICE.

CHARLES K. LONGENECKER, OF PAINTED POST, NEW YORK, ASSIGNOR TO
THE WESTON ENGINE COMPANY, OF SAME PLACE.

STEAM-ENGINE GOVERNOR.

SPECIFICATION forming part of Letters Patent No. 457,322, dated August 4, 1891.

Application filed May 29, 1891. Serial No. 394,553. (No model.)

To all whom it may concern:

Be it known that I, CHARLES K. LONGENECKER, a citizen of the United States, residing at Painted Post, in the county of Steuben and State of New York, have invented certain new and useful Improvements in Steam-Engine Governors; and I do hereby declare the following to be a full, clear, and exact description of the invention, such as will enable others skilled in the art to which it appertains to make and use the same.

This invention relates generally to steam-engine governors, and particularly to that class of governors known as "fly-wheel" governors, such as have a laterally-movable eccentric surrounding the crank-shaft of the engine, and connected by a rod to the valve-stem, by which the admission of steam to cylinder is regulated through the variation of its throw, this variation being effected by the movements of centrifugally-acting weights secured to levers, which are connected to the eccentric, while the centrifugal motion of these weights is resisted by centripetally-acting springs, the free ends of which are attached to weight-levers, the other ends being attached in an adjustable manner to the fly-wheel.

It has been usual heretofore in this class of governors when supplied with sensitizing devices to accomplish adjustment of the springs from two points of the wheel diametrically opposite. This arrangement is necessarily awkward, as it necessitates the turning over of engine one-half revolution before adjustment can be effected, which is often almost impossible. A further disadvantage of the usual device is in the unequal tension given to the springs, which often causes one of the springs to break from having been made to overcome a larger proportion of the centrifugal force than the other; and a further objection is found in the possibility of incompetent engineers adjusting that end of one of the springs which is attached to wheel nearer to or farther from the pivotal point of its lever than the end of the other, thus destroying the governor's sensitiveness according to the degree of error, which is practically without limit. I overcome all these objectionable features by a simple arrangement of parts,

which allows both springs to have their attachment to the wheel on the same side, and admits the use of one screw for the manipulation of both springs to accomplish the sensitive regulation of governors.

The invention further consists in providing for the application of a thoroughly effective governor to a wheel of much smaller size than has been heretofore accomplished, and also to make possible, from the use of a peculiar form of centrifugally-acting weights, the correct design of weight-lever; and it consists in the parts and combinations of parts hereinafter described and claimed.

In the accompanying drawings, forming part of this specification, Figure 1 is a front elevation of my governor, showing the arrangement of connecting-links, springs, &c. Fig. 2 is a vertical cross-section of the same. Figs. 3 and 4 are respectively detail front and side views of my device for regulating the tension of the springs. Figs. 5 and 6 are respectively side and edge views of lever and weight, and Fig. 7 a vertical longitudinal section through weight.

Similar letters refer to similar parts throughout all the views.

A represents a skeleton pulley or balance-wheel having spokes *a* connecting its rim with a central hub *b*, rigidly secured or mounted on the main shaft B of the engine.

C is an eccentric having an elongated slot or opening *c* formed therein, through which the main shaft is inserted, said eccentric being formed or provided with flanges *d*, between which an eccentric-strap (not shown) surrounds the body of the eccentric and connects the same with the valve-rod. The eccentric is provided with a projecting arm D, pivoted at its end to one of the spokes near the rim of the wheel, so as to support said eccentric and permit it to have a free lateral movement within the compass of its slot *c*. To the upper edge of the eccentric at its rear side an arm E is attached or formed, which projects from said edge at an angle greater than a right angle with the arm D, and the end of said arm having formed thereon a boss *e*, drilled and tapped to receive a pivot-pin *f*, to which is pivoted at the rear side of said arm D one end of a connecting-link F, the

other end of said link being pivotally secured to the front face of the heel *g* of the short arm *h* of the weight-lever *G*. The lever *G*, as clearly shown in Fig. 2, is cast with a boss or hub *i*, through which it is pivoted to one of the spokes near the rim of the wheel, and from near the outer end of this hub the short arm *h* of the lever *G* projects at an angle to the weight-arm *j* of the lever and inwardly or toward the center of the wheel. By this construction of the lever its arms are caused to operate or swing in vertical planes distinct from each other, and the short arm *h* traveling in a path outside of that of the weight-arm *j*. The weight-arm *j* is formed on an accurate curve of gradual approach to the pivotal point of the eccentric and has its free end connected with the end of the piston-rod *k* of the piston of a dash-pot *l*, centrally pivoted to that one of the spokes *a* to which the projecting arm *D* of the eccentric is pivoted and between its pivotal point and the eccentric. The short arm *h* of the lever *G* is formed with a heel *g* at the lower corner of its outer or free end and with a toe *m* at the other or upper corner. At the opposite side of the eccentric—that is, the side most remote from lever *G*—a lever *G'* is pivoted through a boss or hub similar to hub *i* of lever *G* to one of the spokes of the wheel at a point near its rim and directly, but not diametrically, opposite the pivotal point of lever *G*, the weight-arm *o* of which lever is in all respects similar to weight-arm *j* of lever *G* and extends in a curved line toward the end of said arm *j*. From near the outer end of the hub of lever *G'* a short arm *p* extends upwardly and away from the arm *o*, but in a line corresponding in curvature with the curve of said arm *o* and in a vertical plane outside the plane of said arm. The end of arm *p* is formed with a boss drilled to receive a pivot-pin *r*, which connects with said arm one end of a link *H*, the other end of said link extending to and being pivotally connected with the toe *m* of the short arm *h* of the lever *G* by means of the pivot-pin *s*. The lever-arms *j* and *o* are each provided with an adjustable weight, which will be presently described.

From the above description, and upon reference to the drawings, it will be observed that the weight-arms project from their hubs and pivotal points in the same general direction and toward each other, causing them when in operation or when thrown out by centrifugal force to swing away from each other and upward instead of, as is customarily the case in this class of governors, one swinging in one direction and the other in another, or one up and the other down, in order to shift the eccentric, which is connected directly to the levers or weight-arms by rods, so that the centrifugal force of one arm or lever is exerted to pull and the other to push the eccentric in the same direction at the same time.

With my construction and arrangement of the parts both lever or weight arms act upon

the eccentric to move it in the same direction; but only one of the levers *G* is connected with the eccentric directly, and that by means of a link *F*, pivoted to the short arm projecting from the hub of a lever at an angle, the other lever *G'* being connected to the rigid short arm or lever *G* by a link whose tendency is to push said short arm downwardly, and thus cause its lower corner or heel to be forced away from the eccentric and in the same direction in which said arm is being moved or swung by its weight-arm *j*, thus rendering the movements of both weight-arms uniform and steady and relieving the engine from the effects of sudden jerks consequent upon change of load or variation in speed.

To the free ends of the weight-arms of the levers *G* *G'*, *I* pivotally attach spiral springs *I*, at points equally distant from the fulcra of said levers, by means of the clevises or yokes *J*. These yokes are formed with an annular collar or ring *k'*, connecting its arms *l'*, through each of which a screw-rod *m'* is inserted, said rods being formed with a head *m²* and having a hexagonal nut *n* cut or formed thereon at such distance from its head as will cause said nut to stand outside of the collar or ring when the rod is in place. On the other end of the screw-rod a nut *T* is applied, said nut having wings or lateral extensions *t* formed thereon and provided with perforations *u*, through which one end of the spring *I* is passed and then riveted over, thus rigidly connecting the spring and nut together, so that the latter will be held immovable against rotation on the screw-rod *m'* when the latter is turned in the ring of the clevis. The other ends of the springs are fitted over the ends of the adjustable pins *M* and in grooves formed therein, said pins being cast with heads or lugs *N*, having tapped openings therein to receive one end of a right and left threaded screw-rod *P*, formed with a hexagonal nut *Q* at its center, said nut, when the parts are in position, lying in a recess *w*, formed or cored in the rear side of the spoke *a*, to which the pins *M* are adjustably attached. This spoke is cast with the projecting lugs *R* at each side or edge thereof, in which are formed the longitudinal slots *S*, adapted to receive and form a sliding surface for the pins *M*, which are moved back and forth in said slots by the right and left threaded screw-rod *P* when the latter is revolved. The pins *M* are reduced at a suitable point, as at *a'*, between their ends to adapt them to fit in said slotted lugs, and the walls of said reduced portion fitting snugly against the sides of the lugs act as guides for the pins in their movements and prevent them being withdrawn longitudinally from or wobbling in the slots.

From the above description it is obvious that upon turning the nut *Q* the screw-rod will move the pins *M* simultaneously away from or toward each other in their respective slots *S*, according to the direction of revolution of screw-rod, and consequently said pins,

with the ends of the springs attached there-
to, will be moved nearer to or farther from the
pivotal points of the levers G G' , and that
each pin will be moved an equal distance,
5 whether that distance be great or small, thus
assuring the accuracy of the adjustment of
the springs relative to the pivotal points of
the levers to equalize the resistance thereof
to the centrifugal force of the weights. As
10 springs of equal size and proportion do not
always possess the same resilience, owing to
difference in temper and other causes, it is
necessary, in order to adjust them with accu-
racy to the centrifugal force exerted by the
15 weights, to provide means for adjusting the
length of the springs to equalize their resis-
tance to the weights at all parts of their
movement, such adjustment being required
as will cause an extreme movement of the
20 weights when a slight variation in the speed
of the wheel occurs. This adjustment I ac-
complish by simply turning the nut n of screw-
rod m' , and thereby turning said rod in the
nut T , attached to end of spring and length-
25 ening or shortening the same, according to
the direction in which the rod is turned, and
thus increasing or decreasing its resistance to
the centrifugal force of the weights, as de-
sired or found necessary in operation.

30 The object of the recess w in the spoke to
which the pins are attached is to prevent any
tendency of the screw-rod to move from its
set position when regulating the governor,
the sides of the hexagon fitting against the
35 walls of the recess, preventing any longitudi-
nal movement of the screw-rod, and were not
the recess or some equivalent therefor em-
ployed one of the pins would not be affected
by the movement of the screw-rod, and would
40 remain stationary, thus destroying the object
sought—equally-divided adjustment of the
springs.

My construction of the device for adjust-
ing the tension of the springs by lengthen-
45 ing and shortening the same enables me to
use the same on wheels of less diameter than
is possible with any of the usual devices em-
ployed for this purpose, and the range of ex-
tension of the spring by my device may be as
50 great as the length of the spring itself with-
out requiring extra space for the operation of
the same, as the screw-rods enter the spring
and pass into the same as it is turned to ex-
tend the spring.

55 In Figs. 5 and 6 I have shown my improved
weight W in connection with a weight-arm to
illustrate the advantage of the same over
weights of different construction. The weight,
which may be of any desired external shape
60 or form—the shape shown, a disk, being
preferred—is formed with a central slot W' ,
in width equal to the thickness of the arm
which extends from the periphery into said
weight for a distance beyond the center of
65 the same equal to about one-half the width
of the weight-arm, and has its bottom W^2
formed on the arc of a circle corresponding to

the curve given the inner edge of the weight-
arm. A set-screw B' enters a screw-threaded
opening formed in the center of the weight 70
and impinges against the side of the lever to
hold the weight in place. It will be noticed
that although over one-half of the edge of
the weight is open and that the weight may
75 be removed without disturbing or disengag-
ing the spring there is no liability of the
weight becoming disengaged from the lever
when the governor is in operation, as the
closed or bottom portion of the slot comes in
80 contact with the edge of the lever-arm near-
est center of gyration, and that consequently
the centrifugal force of the weight tends to
make contact between itself and the arm all
the more positive.

Another advantage I gain by the construc- 85
tion of weight described lies in the fact that
I am able to design the weight-arms to cor-
rect lines, as a gradual increase in width of
arm toward its fulcrum will not interfere
90 either with the attachment of the weight
thereto or with its adjustment longitudinally
thereon for adjustment of speed.

While I have described and illustrated the
preferred construction and arrangement of 95
the different parts of my invention, I do not
desire to be limited to the exact construction
shown and described for adjusting the ends
of the springs simultaneously an equal dis-
tance nearer to or farther from the pivotal
100 points of the lever, as many means may be
employed for accomplishing this adjustment
without departure from the spirit of my in-
vention; nor do I desire to be limited to
the exact construction of the means here-
105 in described for accomplishing the correct ad-
justment of tension of springs in a limited
space, as different forms of nuts, yokes, and
screws may be used for the same purpose
without departure from the scope of my in-
110 vention; nor do I desire to be restricted to the
form of weight nor the means for attaching
the weights to the levers herein described, as
these may be varied to suit the circumstances
and yet be within the spirit and scope of my
115 invention.

Having thus described my invention, what
I claim as new, and desire to secure by Let-
ters Patent, is—

1. The combination, with a fly-wheel, a lat-
erally-movable eccentric, and pivoted weight- 120
levers, one of which has an arm connected
with said eccentric, of springs connected to
the free ends of said levers at one end and to
the fly-wheel at their other ends, and means
for simultaneously moving said latter-named 125
spring ends in opposite directions, substan-
tially as described.

2. The combination, with a fly-wheel, a lat-
erally-movable eccentric having an arm piv- 130
otally secured to said wheel, an arm pro-
jecting at an angle greater than a right angle
with said pivoted arm from said eccentric,
and weight-levers pivoted to the wheel at
points on the same side of the eccentric, of

springs adjustably attached at one end to the wheel on the same side thereof and having their other ends connected with the free ends of the levers, and means for simultaneously
5 adjusting the ends of the springs that are connected to the wheel an equal distance apart, substantially as described.

3. The combination, with a fly-wheel, a laterally-movable eccentric, and pivoted weight-
10 levers, one of which is connected with said eccentric, of springs adjustably connected with said wheel at one end, and means for connecting the other ends of said springs to the free ends of the levers and adapted to adjust the
15 tension of the springs without change of point of connection to lever, substantially as described.

4. The combination, with a fly-wheel, a laterally-movable eccentric, pivoted weight-levers, one of which is provided with a short
20 arm at an angle thereto, a link connecting said arm and the eccentric, and a link connecting said levers, of springs connected at one end to the free ends of the levers and at their
25 opposite ends to the wheel, and means for simultaneously adjusting said last-named ends of the springs an equal distance apart, substantially as described.

5. The combination, with a fly-wheel, a laterally-movable eccentric, pivoted weight-levers, one of which is provided with a short
30 arm projecting at an angle therefrom and the other with a short arm projecting in a curved line corresponding with the curve of the lever, a link connecting said short arms, and a link
35 connecting said eccentric and one of said arms, of springs attached at one end to the free ends of the weight-levers and at their other ends to said wheel, substantially as described.

6. The combination, with a fly-wheel, a laterally-movable eccentric, pivoted weight-levers having short arms, a link connecting
40 said arms, and a link connecting one of said arms and the eccentric, of springs adjustably attached at one end to the wheel at the same side of its center and at their other ends to the free ends of the weight-levers, and means
45 for increasing or decreasing the tension of said springs without changing their points of attachment to the levers or to the wheel, substantially as described.

7. The combination, with a fly-wheel, a laterally-movable eccentric, and pivoted weight-levers, of springs connected at one end to the
55 wheel, nuts secured to the other ends of said springs, screw-rods having hexagons formed thereon entering said nuts, and yokes pivotally secured to the free ends of the levers and adapted to receive one end of said screw-rods, substantially as described.

8. The combination, with a fly-wheel, a laterally-movable eccentric, and pivoted weight-levers, of springs pivotally connected at one
60 end to the free ends of the levers, pins adjustably secured to said wheel, and means for moving said pins simultaneously in opposite directions, substantially as described.

9. The combination, with a fly-wheel, a laterally-movable eccentric, and pivoted weight-levers, of pins adjustably secured to said
70 wheel and having lugs formed with screw-threaded perforations, a rod having right and left screw-threads cut thereon, and a hexagon at its center of length, and springs having one end connected to the free ends of the levers
75 and the other ends to said pins, substantially as described.

10. The combination, with a fly-wheel having a recess and slotted lugs formed on one of the spokes, a laterally-movable eccentric,
80 and pivoted weight-levers, of pins having a reduced portion adapted to fit in said slots, and lugs having screw-threaded perforations, a rod having right and left screw-threads cut thereon and provided with a hexagon, whereby
85 said rod may be revolved, and springs connected with the free ends of said levers and with said pins, substantially as described.

11. The combination, with the curved weight-lever of gradually-increasing width,
90 of a weight having a slot formed therein extending from the periphery beyond the center of said weight and formed with a curved bottom portion, and a screw adapted to secure said weight to said lever, substantially
95 as described.

In testimony whereof I affix my signature in presence of two witnesses.

CHARLES K. LONGENECKER.

Witnesses:

JULIAN SCHOLL,
FRANK E. BRONSON.