



US 20080033395A1

(19) **United States**

(12) **Patent Application Publication**

Alchas

(10) **Pub. No.: US 2008/0033395 A1**

(43) **Pub. Date: Feb. 7, 2008**

(54) **INTRADERMAL DELIVERY DEVICE INCLUDING A NEEDLE ASSEMBLY**

Publication Classification

(76) Inventor: **Paul G. Alchas**, Wayne, NJ (US)

(51) **Int. Cl.**
A61M 5/46 (2006.01)

(52) **U.S. Cl.** **604/506; 604/117**

Correspondence Address:
Richard J. Rodrick, Esq.
Becton Dickinson and Company
1 Becton Drive
Franklin Lakes, NJ 07417 (US)

(57) **ABSTRACT**

(21) Appl. No.: **11/871,012**

A drug delivery device including a needle assembly facilitates making intradermal injections using a variety of drug container types such as a syringe. A hub supports the needle while a limiter surrounds the needle. The limiter includes a skin engaging surface that is adapted to be received against the skin of an animal to be intradermally injected. A forward end of the needle extends beyond the skin engaging surface a selected distance to limit a depth that the needle penetrates into the animal's skin.

(22) Filed: **Oct. 11, 2007**

Related U.S. Application Data

(60) Continuation of application No. 09/825,017, filed on Apr. 3, 2001, which is a division of application No. 09/417,671, filed on Oct. 14, 1999, now Pat. No. 6,494,865.

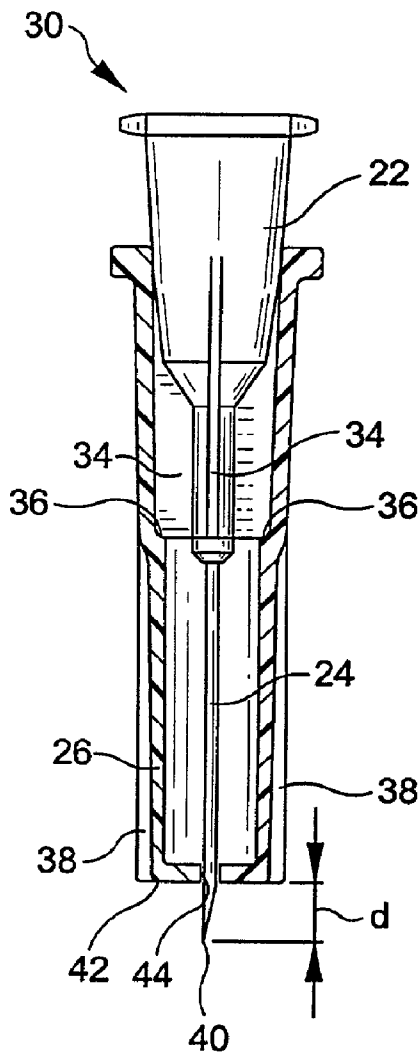

FIG. 1

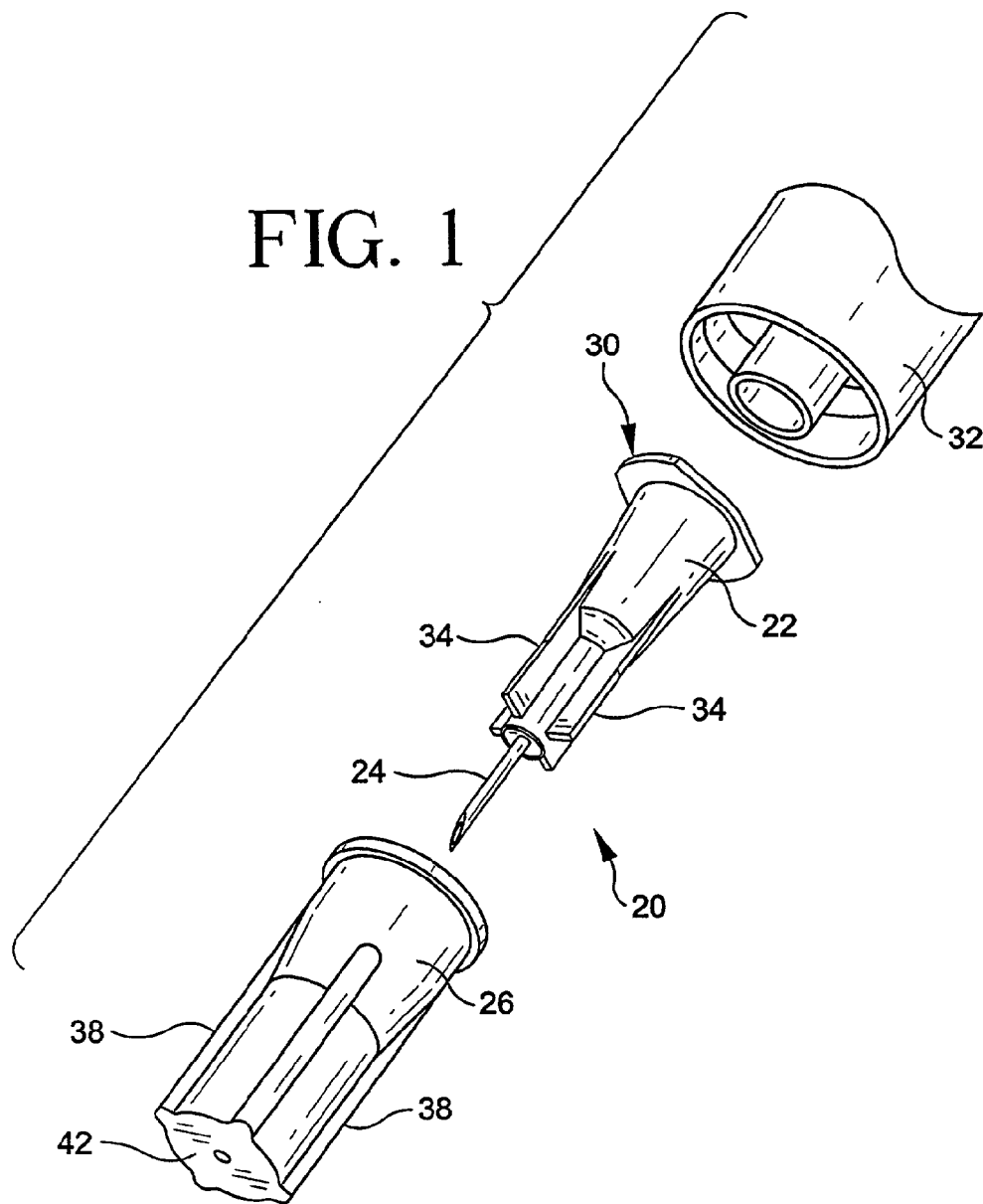
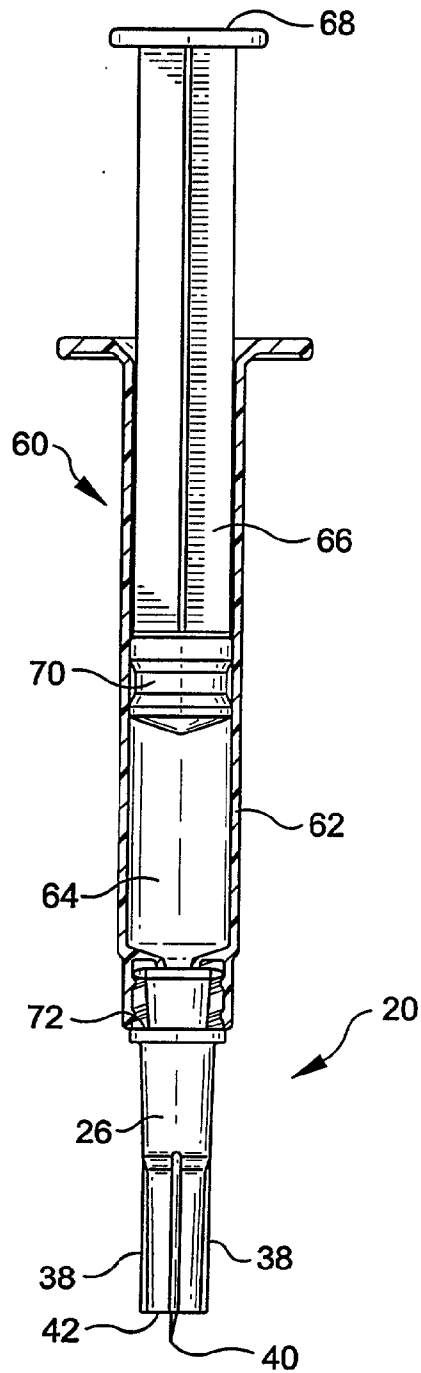
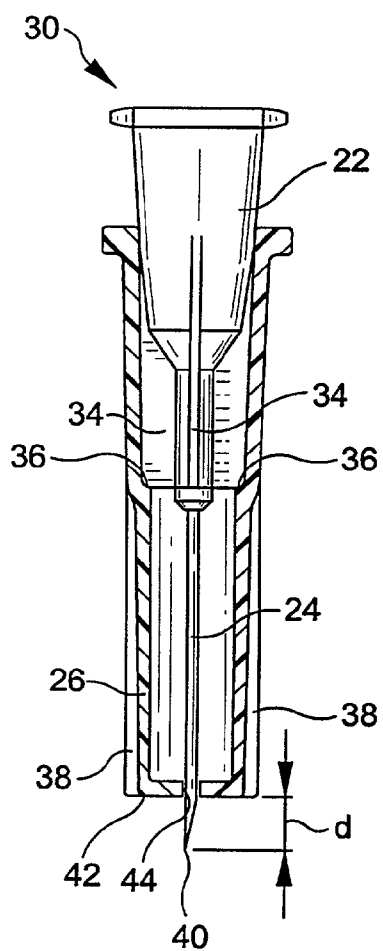

FIG. 3

FIG. 2



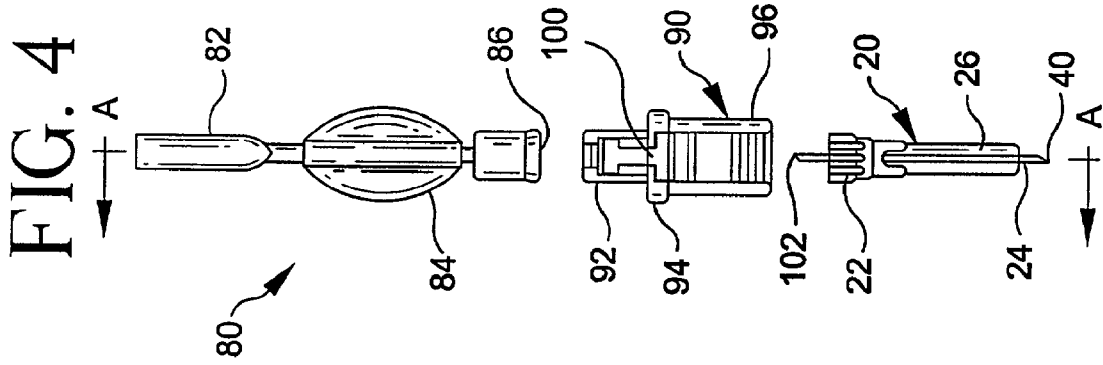
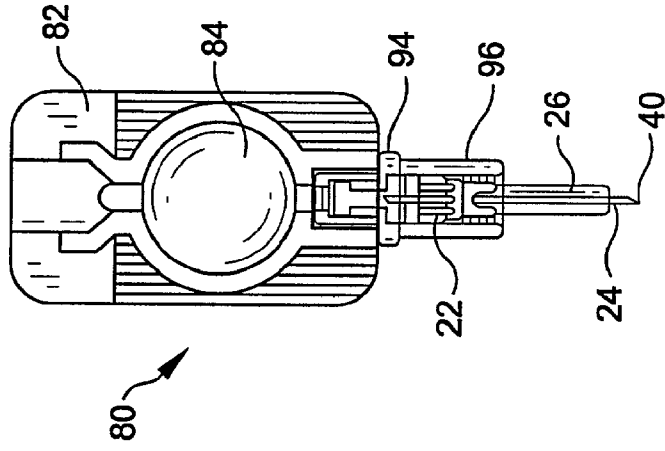

FIG. 5



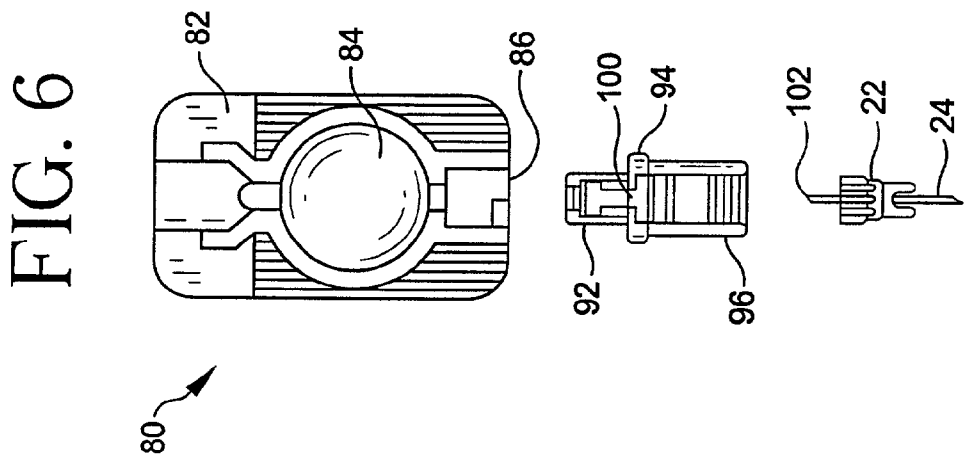
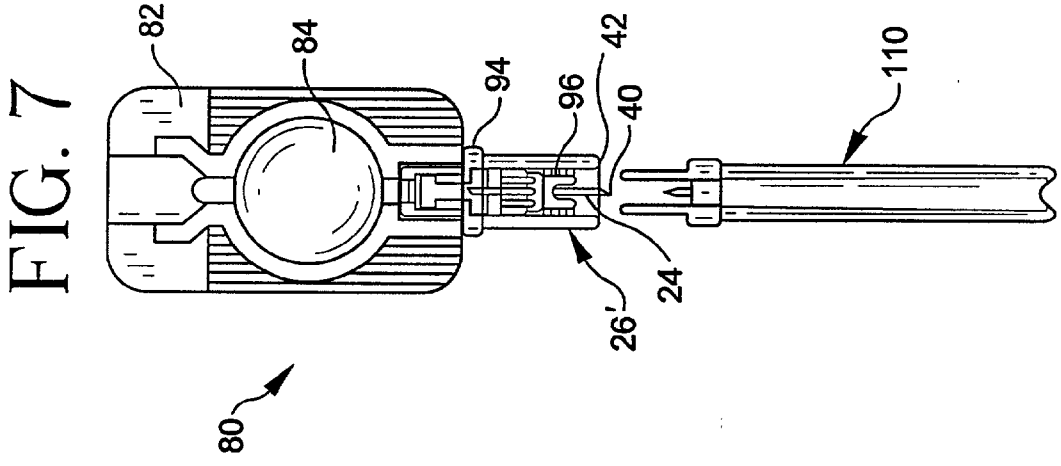
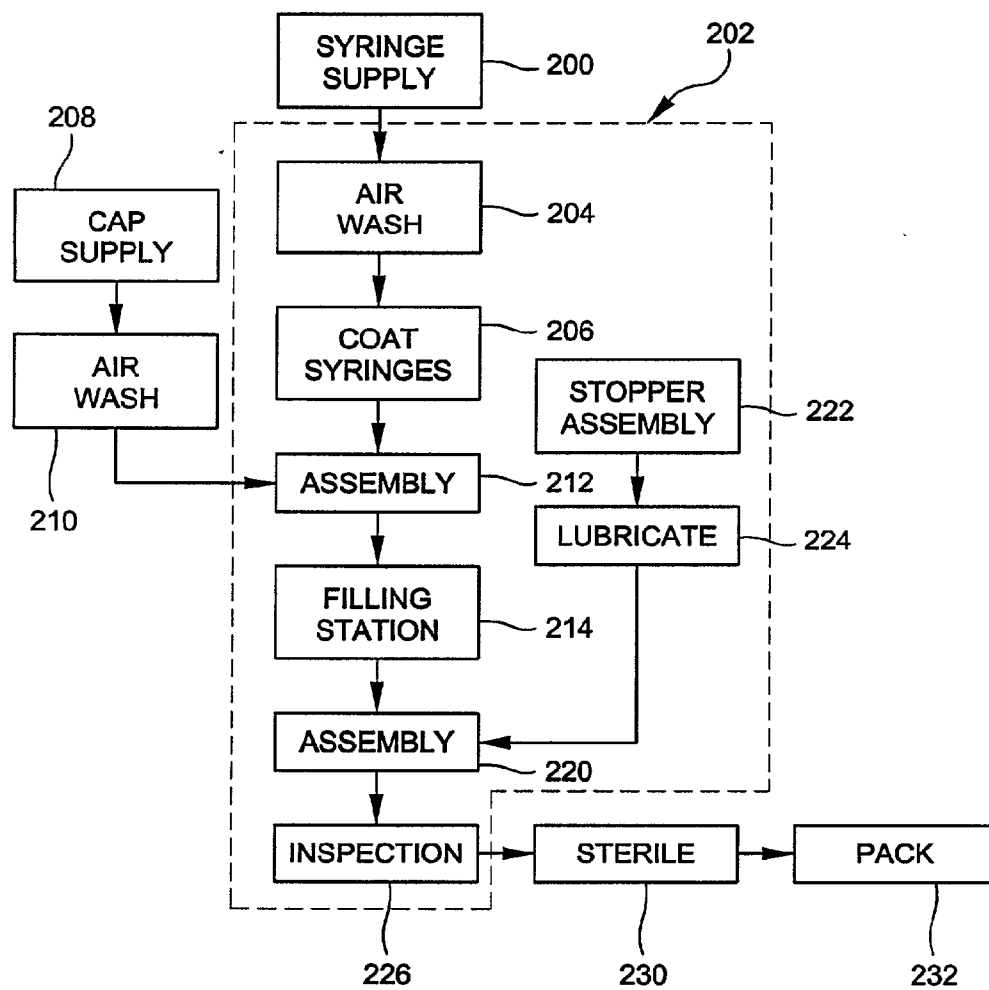

FIG. 8



INTRADERMAL DELIVERY DEVICE INCLUDING A NEEDLE ASSEMBLY

CROSS-REFERENCE TO RELATED APPLICATIONS

[0001] This application is a continuation of Ser. No. 09/825,017, filed Apr. 3, 2001, which is a divisional application of Ser. No. 09/417,671 filed Oct. 14, 1999, now patented as U.S. Pat. No. 6,494,865.

FIELD OF THE INVENTION

[0002] The present invention generally relates to delivery devices for delivering substances such as drugs, vaccines and the like, and more specifically relates to a drug delivery device for injecting such substances intradermally, i.e., into the skin. In addition, the present invention relates to a needle assembly that is adaptable for use with a variety of drug containers such as syringes for making intradermal injections.

BACKGROUND OF THE INVENTION

[0003] A wide variety of hypodermic injection devices are commercially available. Most hypodermic injections are intended to be intramuscular so that the hypodermic needle penetrates through an individual's skin layer and subcutaneous tissue and into the muscle tissue. Under some circumstances, however, limited needle penetration is desired. Under some circumstances, for example, an intradermal injection is desired where the needle does not penetrate beyond the dermis layer.

[0004] One technique for administering intradermal injections is known as the Mantoux procedure. A Mantoux procedure is relatively complicated and requires technical skill from the medical professional or individual administering the injection. Additionally, the Mantoux procedure can prove painful for the individual receiving the injection, especially when somebody without experience is administering the injection.

[0005] Devices have been proposed for providing intradermal injections, which include shortened needles compared to conventional needle sizes. The smaller needles are not intended to penetrate beyond the dermis layer of the individual. Such devices are shown in U.S. Pat. No. 5,527,288, which issued on Jun. 18, 1996; U.S. Pat. No. 4,886,499, which issued on Dec. 12, 1989; and U.S. Pat. No. 5,328,483, which issued on Jul. 12, 1994. The proposed devices, however are not without shortcomings and drawbacks.

[0006] For example, the devices shown in U.S. Pat. Nos. 5,527,288 and 4,886,499 are highly specialized injectors. The designs for these injectors include relatively complex arrangements of components that cannot be economically manufactured on a mass production scale. Therefore, such devices have limited applicability and use.

[0007] Similarly, the device shown in U.S. Pat. No. 5,328,483 requires a specially designed injector and, therefore, it is not readily adapted to be used with a variety of syringe types. Additionally, the assembly of that patent is not conducive to economical mass production.

[0008] There is need for an intradermal injection device that is suitable for use with a variety of syringe bodies.

Additionally, there is a need for an intradermal injection device that can be economically manufactured on a mass production scale. This invention addresses those needs and avoids the shortcomings and drawbacks discussed above.

SUMMARY OF THE INVENTION

[0009] In contrast to the prior devices discussed above, it has been found that a drug delivery device particularly suited for use in intradermally injecting substances such as drugs, vaccines and the like can be constructed in accordance with the present invention. Specifically, the present invention is directed to a drug delivery device including a needle assembly for use in making intradermal injections. The needle assembly has an adapter that is attachable to prefillable containers such as syringes and the like. The needle assembly is supported by the adapter and has a hollow body with a forward end extending away from the adapter. A limiter surrounds the needle and extends away from the adapter toward the forward end of the needle. The limiter has a skin engaging surface that is adapted to be received against the skin of an animal such as a human. The needle forward end extends away from the skin engaging surface a selected distance such that the limiter limits the amount or depth that the needle is able to penetrate through the skin of an animal.

[0010] In addition, the present invention is directed to a method of intradermally injecting at least one substance into the skin including the steps of pressing the needle perpendicularly to the skin of the person to receive an injection, injecting the substance into skin of the person with the depth of penetration of the needle being mechanically limited to the intradermal space by the limiter that surrounds the needle. Also, in the preferred embodiment, the step of pressing the needle perpendicularly to the skin of the person includes orienting the needle perpendicularly to the skin, and the step of injecting the substance either includes moving a plunger that is received within the reservoir or deflecting two sheets of thermoplastic material forming the reservoir toward each other to expel the substance from the reservoir during an injection.

[0011] The various features and advantages of this invention will become apparent to those skilled in the art from the following detailed description of the currently preferred embodiments. The drawings that accompany the detailed description can be briefly described as follows.

BRIEF DESCRIPTION OF THE DRAWINGS

[0012] FIG. 1 is an exploded, perspective illustration of a needle assembly designed according to this invention.

[0013] FIG. 2 is a partial cross-sectional illustration of the embodiment of FIG. 1.

[0014] FIG. 3 shows the embodiment of FIG. 2 attached to a syringe body to form an injection device.

[0015] FIG. 4 is an exploded, side view of another embodiment of an injection device designed according to this invention.

[0016] FIG. 5 is a cross-sectional illustration taken along the lines A-A in FIG. 4 but showing the components in an assembled condition.

[0017] FIG. 6 is an exploded, cross-sectional view similar to that shown in FIG. 5 showing an alternative embodiment.

[0018] FIG. 7 shows the embodiment of FIG. 6 in an assembled condition.

[0019] FIG. 8 is a flow chart diagram that schematically illustrates a method of filling a device designed according to this invention.

DETAILED DESCRIPTION OF THE PREFERRED EMBODIMENTS

[0020] FIGS. 1 and 2 diagrammatically illustrate the needle assembly 20 of the present invention that is designed to be used for making intradermal injections, FIG. 3 illustrates the drug container such as syringe 60 for use with the needle assembly 20, and FIGS. 4-7 illustrated the intradermal delivery device 80 of the present invention for making intradermal injections. Intradermal injections include administering substances such as drugs, vaccines and the like into the skin of an animal such as a human.

[0021] The needle assembly 20 includes a hub 22 that supports a needle 24. The limiter 26 receives at least a portion of the hub 22 so that the limiter 26 generally surrounds the needle 24 as best seen in FIG. 2.

[0022] One end 30 of the hub 22 is able to be secured to a receiver 32 of a syringe. A variety of syringe types can be used with a needle assembly designed according to this invention, with several examples being given below. The opposite end of the hub 22 preferably includes extensions 34 that are nestingly received against abutment surfaces 36 within the limiter 26. A plurality of ribs 38 preferably are provided on the limiter 26 to provide structural integrity and to facilitate handling the needle assembly 20.

[0023] By appropriately designing the size of the components, a distance d between a forward end or tip 40 of the needle 24 and a skin engaging surface 42 on the limiter 26 can be tightly controlled. The distance d preferably is in a range from approximately 0.5 millimeters to approximately 3 millimeters. When the forward end 40 of the needle 24 extends beyond the skin engaging surface 42 a distance within that range, an intradermal injection is ensured because the needle is unable to penetrate any further than the typical dermis layer of an animal. Typical tissue layers include an epidermis between 50 and 100 micrometers, a dermis layer between 2 and 3 mm then subcutaneous tissue followed by muscle tissue.

[0024] As can be best seen in FIG. 2, the limiter 26 includes an opening 44 through which the forward end 40 of the needle 24 protrudes. The dimensional relationship between the opening 44 and the needle 40 can be controlled depending on the needs of a particular situation. For example, the skin engaging surface 42 surrounding the needle 24 has a thickness defined between an inner diameter and an outer diameter and the inner diameter is at least five times greater than an outside diameter of the needle 24. In the illustrated embodiment, the skin engaging surface 42 is generally planar and continuous and provides a stable placement of the needle assembly 20 against an animal's skin. Although not specifically illustrated, it may be advantageous to have the skin engaging surface be slightly concave or convex in order to facilitate stretching or gathering the animal's skin in the vicinity of the needle tip 40 to facilitate

making an injection. Additionally, the ribs 38 may be extended beyond the skin engaging surface 42 to further facilitate manipulating the skin in the vicinity where the injection is to be given.

[0025] Regardless of the shape or contour of the skin engaging surface 42, the preferred embodiment includes enough of a surface area that contacts the skin to facilitate stabilizing the injector relative to the animal's skin. In the most preferred arrangement, the skin engaging surface 42 facilitates maintaining the injector in a generally perpendicular orientation relative to the skin surface.

[0026] It is important to note that although FIGS. 1 and 2 illustrate a two-piece assembly where the hub 22 is made separate from the limiter 26, this invention is not limited to such an arrangement. Forming the hub 22 and limiter 26 integrally from a single piece of plastic material is an alternative to the example shown in FIGS. 1 and 2. Additionally, it is possible to adhesively or otherwise secure the hub 22 to the limiter 26 in the position illustrated in FIG. 2 so that the needle assembly 20 becomes a single piece unit upon assembly.

[0027] Having a hub 22 and limiter 26 provides the advantage of making an intradermal needle practical to manufacture. The preferred needle size is a small gauge hypodermic needle, commonly known as a 30 gauge or 31 gauge needle. Having such a small diameter needle presents a challenge to make a needle short enough to prevent undue penetration beyond the dermis layer of an animal. The limiter 26 and the hub 22 facilitate utilizing a needle 24 that has an overall length that is much greater than the effective length of the needle, which penetrates the individual's tissue during an injection. With a needle assembly designed according to this invention, manufacturing is enhanced because larger length needles can be handled during the manufacturing and assembly processes while still obtaining the advantages of having a short needle for purposes of completing an intradermal injection.

[0028] FIG. 3 illustrates a needle assembly 20 secured to a drug container such as a syringe 60. A generally cylindrical syringe body 62 can be made of plastic or glass as is known in the art. The syringe body 62 provides a reservoir 64 for containing a substance to be administered during an injection. A plunger 66 has a manual activation flange 68 at one end with a stopper 70 at an opposite end as known in the art. Manual movement of the plunger 66 through the reservoir 64 forces the substance within the reservoir 64 out of the end 40 of the needle as desired.

[0029] The hub 22 can be secured to the syringe body 62 in a variety of known manners. In one example, an interference fit is provided between the interior of the hub 22 and the exterior of the outlet port portion 72 of the syringe body 62. In another example, a conventional luer fit arrangement is provided to secure the hub 22 on the end of the syringe 60. As can be appreciated from FIG. 3, a needle assembly designed according to this invention is readily adaptable to a wide variety of conventional syringe styles.

[0030] FIGS. 4 and 5 illustrate an alternative embodiment of an intradermal delivery device 80 that includes a syringe made from two sheets of thermoplastic material. The syringe includes a body portion 82 that is generally flat and surrounds a reservoir 84. An outlet port 86 allows fluid sub-

stance within the reservoir **84** to be communicated out of the reservoir to administer an injection. The syringe body preferably is formed using a thermoforming process as is known in the art.

[0031] A receiver **90** includes a generally cylindrical neck portion **92** that preferably is secured to the outlet port **86** using a heating or welding process as known in the art. A flange **94** preferably rests against the body portion **82** of the syringe to provide structural integrity. An extension **96** extends away from the flange **94** in a direction opposite from the cylindrical portion **92**. The needle assembly **20** preferably is received within the extension **96** as shown in FIG. 5.

[0032] The receiver **90** preferably supports a sealing membrane **100** that closes off the outlet port **86** so that the syringe can be prefilled. The needle assembly **20** preferably includes a back end **102** of the needle that penetrates the sealing membrane **100** when the hub **22** is received within the extension **96**.

[0033] The side walls of the reservoir **84** preferably are squeezed between a thumb and index finger so that the side walls collapse towards each other and the substance within the reservoir **84** is expelled through the opening in the forward end **40** of the needle **24**. In the embodiment of FIGS. 4 and 5, the hub **22** and limiter **26** preferably are integrally molded as a single piece of plastic material. A snap fit arrangement secures the hub **22** within the extension **96** of the receiver **90**. Another alternative is illustrated in FIGS. 6 and 7. In this embodiment, the hub **22** is molded separately from the limiter **26'**, which is integrated with the extension **96**. A difference between the embodiments of FIGS. 6 and 7 compared to that of FIGS. 4 and 5 includes an elongated extension **96** so that the side wall of the extension **96** provides the skin engaging surface **42'** of the limiter **26'**. In this embodiment, the limiter is supported by the syringe body. By appropriately choosing the dimensions of the needle **24** and the length of the extension **96**, the desired distance *d* between the skin engaging surface **42** and the needle tip **40** can be achieved.

[0034] FIG. 7 also illustrates a needle shield **110**, which preferably is provided on the hub **22** and needle **24**. The needle shield **110** facilitates inserting the hub **22** within the receiver **90** until the hub **22** is appropriately received within the extension **96** so that the intradermal delivery device **80** is ready for use. The needle shield **110** can be discarded after the hub **22** is in position. Alternatively, the needle shield **110** can be replaced over the needle **24** after an injection is complete to avoid the possibility for a needle stick while handling the intradermal delivery device **80** after it has been used. Although the shield **110** is only shown in FIG. 7, it preferably is utilized with the embodiments of FIGS. 4-7.

[0035] This invention provides an intradermal needle injector that is adaptable to be used with a variety of syringe types. Therefore, this invention provides the significant advantage of facilitating manufacture and assembly of intradermal needles on a mass production scale in an economical fashion.

Operation and Use

[0036] Having described the preferred embodiments of the intradermal delivery device **80** of the present, including the needle assembly **20** and drug container **60**, its operation and use is described below.

[0037] Use of the delivery device to administer substances such as drugs, vaccines and the like into the intradermal layer is significantly easier than with a traditional syringe and needle. Using a traditional syringe and needle is technique-dependent and requires considerable skill to develop an acceptable skin wheal. In particular, the needle must be carefully guided at a shallow angle under the skin while maintaining correct orientation of the needle bevel. In contrast, with a prefilled intradermal delivery device of the present invention, the user simply presses the device perpendicularly on to the skin and injects the substance. The depth of penetration of the needle is mechanically limited to the intradermal space. In this way, there is no need to orient the needle bevel during injection. Orienting the device, particularly the needle, perpendicularly to the skin, as well as stability while injecting the substance, is facilitated by the design of the device.

[0038] Referring now to FIG. 8, an example method of filling devices designed according to this invention is schematically illustrated in flow chart format. When the device includes a syringe of the style illustrated in FIG. 3, the following basic procedure is useful for prefilling the syringes with a desired substance.

[0039] A supply of syringe barrels **200** includes the desired form of syringe, such as those illustrated and discussed above. A locally controlled environment **202** preferably is maintained in a known manner. The locally controlled environment **202** preferably is situated to immediately accept the syringes without requiring any intermediate cleaning or sterilizing steps between the supply **200** and the environment **202**.

[0040] In one example, the syringe barrels are washed with air at **204** to remove any particulates from the syringes. The syringes preferably are then coated at **206** with a lubricant such as a lubricating silicone oil on the inner surface. The lubricant facilitates moving the stopper **70** and plunger rod **66** through the syringe during actual use of the device.

[0041] The end of syringes that eventually will need needle assembly **20** may be capped with a tip cap within the environment **202**. In one example, tip caps are supplied at **208**. The tip caps are air washed at **210**. The cleaned tip caps and syringe barrels are conveyed to an assembly device **212** where the tip caps are secured onto the syringes. The syringe barrel assemblies are then conveyed to a filling station **214** to be filled with the desired substance.

[0042] Once filled as desired, the stoppers **70** are inserted into the open end of the syringes at **220**. Prior to inserting the stoppers **70**, they preferably are assembled with the plunger rods **66** at **222** and lubricated at **224** with a conventional lubricant in a known manner. The assembled, filled syringes preferably are inspected at **226** for defects and discharged from the locally controlled environment.

[0043] The syringes typically will be sterilized at **230** and packaged at **232** into individual packages or into bulk packaging depending on the needs of a particular situation. Suitable sterilization techniques are known and will be chosen by those skilled in the art depending on the needs of a particular situation or to accommodate the properties of a given substance. Sterilizing a device designed according to this invention can be completed before or after packaging.

[0044] Variations of the filling steps are within the scope of this invention. For example, the stopper can be inserted first, then fill the syringe, followed by applying a tip cap. Additionally, when the device includes a syringe body of the type shown in FIGS. 4 and 5, for example, the filling operation obviously does not include insertion of a stopper nor the lubrication steps described above. Instead, appropriate filling techniques that are known are utilized.

[0045] The actual insertion of the desired substance into the syringe body can be accomplished in any of several known manners. Example filling techniques are disclosed in U.S. Pat. No. 5,620,425 to Hefferman et al.; U.S. Pat. No. 5,597,530 to Smith et al.; U.S. Pat. No. 5,537,042 to DeHaen; U.S. Pat. No. 5,531,255 to Vacca; U.S. Pat. No. 5,519,984 to Veussink et al.; U.S. Pat. No. 5,373,684 to Veussink et al.; U.S. Pat. No. 5,265,154 to Liebert et al.; U.S. Pat. No. 5,287,983 to Liebert et al.; and U.S. Pat. No. 4,718,463 to Jurgens, Jr. et al., each of which is incorporated by reference into this specification.

[0046] The description given above provides example implementations of this invention. Variations and modifications may become apparent to those skilled in the art that do not necessarily depart from the basis of this invention. The scope of legal protection given to this invention can only be determined by studying the following claims.

What is claimed is:

1. A hypodermic needle assembly for use in making intradermal injections, comprising:

a hub portion that is able to be attached to a drug container;

a needle supported by the hub portion, the needle having a hollow body with a forward end extending away from the hub portion; and

a limiter portion that that is non-movable with respect to said hub portion and said limiter surrounds the needle and extends away from the hub portion toward the forward end of the needle, the limiter portion having a skin engaging surface that is adapted to be received against skin of an animal to receive an intradermal injection, the needle forward end extending beyond the skin engaging surface a selected distance such that the limiter portion limits an amount that the needle is able to penetrate through the skin of an animal.

2. The assembly of claim 1, wherein the hub portion and the limiter portion are integrally formed as a single piece made from a plastic material.

3. The assembly of claim 1, wherein the hub portion and the limiter portion are formed as separate pieces.

4. The assembly of claim 3, wherein the limiter portion includes an inner cavity that receives at least a portion of the hub portion and the inner cavity includes an abutment surface that engages corresponding structure on the hub portion to thereby limit the amount that the needle forward end extends beyond the skin engaging surface.

5. The assembly of claim 3, wherein the limiter portion is integrally formed as part of the syringe and the hub portion is received within the limiter portion.

6. The assembly of claim 5, wherein the skin engaging surface surrounds the needle, and has a thickness defined between an inner diameter and an outer diameter and

wherein the inner diameter is at least five times greater than an outside diameter of the needle.

7. The assembly of claim 6, wherein the skin engaging surface is generally circular.

8. The assembly of claim 1, wherein the skin engaging surface includes a central opening that is slightly larger than an outside dimension of the needle and the skin engaging surface is continuous.

9. The assembly of claim 1, wherein the skin engaging surface is generally flat and defines a plane that is generally perpendicular to an axis of the needle and that is adapted to be received against skin of an animal to limit the penetration depth of the forward end of the needle and to maintain the needle in generally perpendicular orientation relative to the skin of the animal during the intradermal injection, the needle forward end extending beyond the skin engaging surface a preselected distance such that the penetration depth of the needle into the skin of the animal is limited to the dermis layer of the skin of the animal.

10. The needle assembly of claim 1, wherein the selected distance that the forward end of the needle extends beyond the skin engaging surface is fixed.

11. The assembly of claim 1, wherein the selected distance is in the range from approximately 0.5 mm to approximately 3 mm.

12. The assembly of claim 1, wherein the skin engaging surface includes a contact surface area that is large enough to stabilize the assembly in a desired orientation relative to the skin.

13. The assembly of claim 12, wherein the desired orientation is generally perpendicular to the skin.

14. The assembly of claim 1, wherein the drug container is a syringe and the animal is human.

15. An intradermal delivery device for use in making intradermal injections, comprising:

a drug container having a reservoir adapted to contain a selected substance and an outlet port that allows the substance to exit the reservoir during an injection, wherein said drug container comprises a syringe having a generally flat body portion that at least partially surrounds the reservoir, the body portion and the reservoir being made from two sheets of thermoplastic material such that side walls of the reservoir are selectively deflectable toward each other to expel a substance from the reservoir during an injection;

a needle in fluid communication with the outlet port, the needle having a forward end that is adapted to penetrate the skin of an animal; and

a limiter that is non-movable with respect to said hub portion and said limiter surrounds the needle and has a skin engaging surface that is adapted to be placed against the skin of the animal to receive an intradermal injection, the needle forward end extending away from the skin engaging surface a selected distance such that the limiter limits an amount that the needle forward end penetrates the skin, wherein said limiter is non-movable and limits penetration of the needle into the dermis layer of skin of the animal so that the substance is injected into the dermis layer of the animal.

16. The device of claim 15, wherein the drug container is a syringe including a generally hollow, cylindrical body portion and a plunger that is received within the reservoir,

the plunger being selectively movable within the reservoir to cause the substance to be forced out of the outlet port during an injection.

17. The device of claim 15, including a hub portion that supports the needle and the hub portion is selectively secured to the drug container near the outlet port.

18. The device of claim 15, wherein the drug container is a syringe includes a generally flat body portion that at least partially surrounds the reservoir, the body portion and the reservoir are made from two sheets of thermoplastic material such that side walls of the reservoir are selectively deflected toward each other to expel a substance from the reservoir during an injection.

19. The device of claim 18, including a hub that supports the needle and is selectively secured to the syringe near the outlet port and a receiver adjacent the outlet port that is generally circular and the hub is completely received within the receiver and wherein the limiter is integrally formed with the receiver such that the limiter is permanently supported by the body portion adjacent the outlet port.

20. The device of claim 19, wherein the skin engaging surface surrounds the needle, and has a thickness defined between an inner diameter and an outer diameter and wherein the inner diameter is at least five times greater than an outside diameter of the needle.

21. The device of claim 20, wherein the skin engaging surface is generally circular.

22. The device of claim 19, wherein the needle forward end extends away from the hub in a first direction and a needle back end extends away from the hub in a second direction, and including a sealing membrane that closes off the outlet port and wherein the needle back end pierces the sealing membrane when the hub is received by the receiver.

23. The device of claim 18, including a hub that supports the needle and is selectively secured to the syringe near the outlet port and a receiver adjacent the outlet port that is generally circular and the hub is completely received within the receiver and wherein the limiter is formed separately from the receiver and is at least partially received by the receiver.

24. The device of claim 23, wherein the limiter and the hub are integrally formed into a single piece structure.

25. The device of claim 15, wherein the needle has a length and wherein the selected distance is much less than the needle length.

26. The device of claim 25, wherein the selected distance is fixed and is in the range from approximately 0.5 mm to approximately 3 mm.

27. The device of claim 15, wherein the skin engaging surface is generally flat and defines a plane that is generally perpendicular to an axis of the needle and that is adapted to be received against skin of an animal to limit the penetration depth of the forward end of the needle and to maintain the needle in generally perpendicular orientation relative to the skin of the animal during the intradermal injection, the needle forward end extending beyond the skin engaging surface a preselected distance such that the penetration depth of the needle into the skin of the animal is limited to the dermis layer of the skin of the animal.

28. The device of claim 15, wherein the skin engaging surface includes a central opening that is slightly larger than an outside dimension of the needle and the skin engaging surface is continuous.

29. The device of claim 15, wherein the skin engaging surface includes a contact surface area that is large enough to stabilize the assembly in a desired orientation relative to the skin.

30. The device of claim 15, wherein the desired orientation is generally perpendicular to the skin.

31. The device of claim 15, wherein the drug container is prefilled with a substance.

32. A method of intradermally injecting at least one substance such as a drug, vaccine or the like into the skin, comprising the steps of:

pressing a needle perpendicularly to the skin, said needle in fluid communication with an outlet port of a drug container having a reservoir adapted to contain a selected substance and the outlet port providing an exit path for the substance from the reservoir during an intradermal injection;

injecting the substance into the skin with the depth of penetration of the needle being limited to the intradermal space of the skin by a non-movable limiter that surrounds the needle and has a skin engaging surface that is adapted to be placed against the skin and a forward end of the needle extending away from the skin engaging surface a selected distance such that the limiter limits penetration of the needle forward end to the dermis layer of the skin so that the substance is injected into the dermis layer of the skin, said step of injecting the substance comprising deflecting at least two sheets of thermoplastic material forming a generally flat body portion that at least partially surrounds the reservoir toward each other to expel the substance from the reservoir during an injection.

33. The method of claim 32, wherein the step of pressing the needle perpendicularly to the skin of the animal includes orienting the needle perpendicularly to the skin.

34. The method of claim 32, wherein the step of injecting the substance includes moving a plunger that is received within the reservoir, with the plunger being selectively movable within the reservoir to cause the substance to be forced out of the outlet port during the injection.

35. The method of claim 32, wherein the step of injecting the substance into the skin of the animal includes deflecting at least two sheets of thermoplastic material forming a generally flat body portion that at least partially surrounds the reservoir toward each other to expel the substance from the reservoir during an injection.

36. The method of claim 32, further comprising the step of filling the drug container with the substance to be intradermally injected.

37. The method of claim 32, wherein said drug container is a syringe and said animal is human.

* * * * *