



(11) **EP 2 105 401 A2**

(12) **EUROPEAN PATENT APPLICATION**

(43) Date of publication:
30.09.2009 Bulletin 2009/40

(51) Int Cl.:
B65H 67/08 (2006.01)

(21) Application number: **09003055.2**

(22) Date of filing: **03.03.2009**

(84) Designated Contracting States:
AT BE BG CH CY CZ DE DK EE ES FI FR GB GR HR HU IE IS IT LI LT LU LV MC MK MT NL NO PL PT RO SE SI SK TR
Designated Extension States:
AL BA RS

(72) Inventor: **NAKAGAWA, Takashi**
Kyoto-shi
Kyoto 612-8686 (JP)

(30) Priority: **28.03.2008 JP 2008088646**

(74) Representative: **Schoppe, Fritz et al**
Schoppe, Zimmermann, Stöckeler & Zinkler
Patentanwälte
Postfach 246
82043 Pullach bei München (DE)

(71) Applicant: **Murata Machinery, Ltd.**
Kyoto-shi,
Kyoto 6018326 (JP)

(54) **Yarn end retrieving apparatus**

(57) A yarn end retrieving apparatus includes a yarn releasing device (3) that sucks and releases a yarn end from a surface of a bobbin (1), a cutter device (10) that cuts the yarn (Y) sucked out by the yarn releasing device (3), and a cylinder elevating and lowering device (16) that elevates and lowers a suction cylinder (13). The cylinder elevating and lowering device (16) is composed of a guide member (17), a slider (19) that slidably elevates and lowers along the guide member, and a driving structure that uses a stepping motor (25) as a driving source. The suction cylinder (13) is fixed to the slider (19) so as to be movable together with the slider. Power of the stepping motor (25) is used to elevate and lower the suction cylinder (13).

FIGURE 1

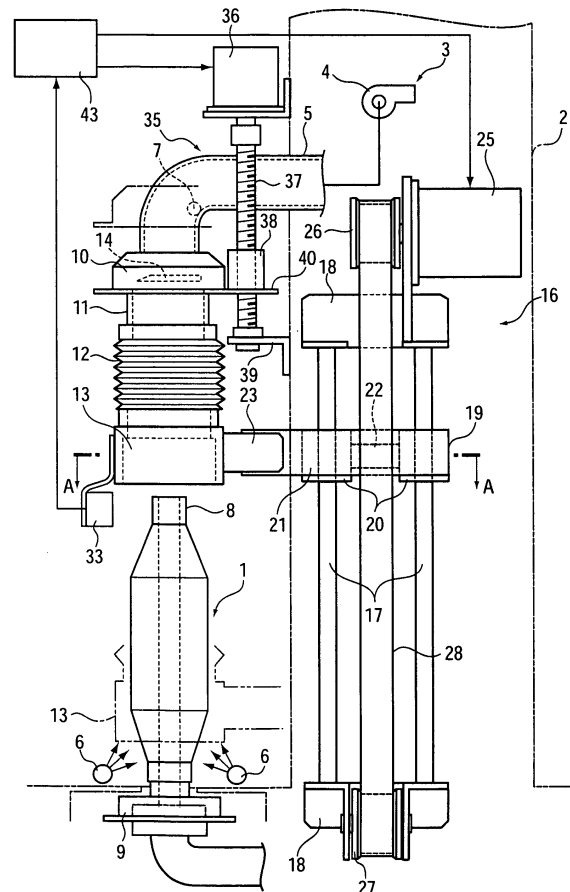

EP 2 105 401 A2

Description

BACKGROUND OF THE INVENTION

Field of the Invention

[0001] The present invention relates to a yarn end retrieving apparatus which releases a yarn end from a surface of a bobbin (spinning bobbin), cuts the released yarn to a given length, and sucks the cut yarn into a winding core of the bobbin.

Description of the Related Art

[0002] A yarn end retrieving apparatus of this kind is well known from the Unexamined Japanese Patent Application Publication (Tokkai-Hei) No. 7-97142. In the yarn end retrieving apparatus, an entire surface of a bobbin is covered with a suction cylinder. Suction air is applied to the suction cylinder to suck a yarn end from the bobbin surface. The suction cylinder is supported and guided so as to elevate and lower freely, by a guide structure provided in the yarn end retrieving apparatus. An operation cylinder can operate the suction cylinder so that the suction cylinder moves between a standby position above the bobbin and a lowered position where the suction cylinder covers the entire surface of the bobbin.

[0003] The suction cylinder is suspended by a cutter device via a flexible cylinder via a flexible cylinder that can be expanded and contracted in a vertical direction. A yarn sucked out via the suction cylinder can be cut to a predetermined length by the cutter device. The cutter device also serves as a shutter that blocks the suction air. The guide structure is composed of a pair of guide shafts, a slider slidably guided along the guide shafts, and others. The suction cylinder is fixed to the slider so as to be able to move together with the slider.

[0004] According to the present invention, an elevating and lowering mechanism using a stepping motor as a driving source elevates and lowers the suction cylinder. A similar elevating and lowering mechanism is described in the Unexamined Japanese Patent Application Publication (Tokkai-Hei) No. 8-324892. According to the Unexamined Japanese Patent Application Publication (Tokkai-Hei) No. 8-324892, the elevating and lowering mechanism elevates and lowers a yarn end releasing member and is composed of, for example, a vertical pair of belt rollers, a belt wound around both belt rollers, and a reversible motor that rotationally drives one of the belt rollers. The yarn end releasing member is fixed to a straight traveling portion of the belt so as to be movable together with the belt via a carriage.

BRIEF SUMMARY OF THE INVENTION

[0005] In a yarn end retrieving apparatus of this kind, the standby position of the suction cylinder is changed depending on the vertical size of the bobbin. A lower end

of the suction cylinder is placed at a predetermined position above an upper end of the bobbin. In the yarn end retrieving apparatus in the Unexamined Japanese Patent Application Publication (Tokkai-Hei) No. 7-97142, since the operation cylinder elevates and lowers the suction cylinder, stoppers are provided in a middle part of a reciprocating stroke of the operation cylinder to allow the standby position of the suction cylinder to be changed.

[0006] Specifically, the stoppers are installed on the guide shafts of the guide structure. An elevation upper limit position of a slider can be changed by changing positions where the stoppers are fixed. Thus, the standby position of the suction cylinder can be changed in the vertical direction. As described above, in the yarn end retrieving apparatus in the Unexamined Japanese Patent Application Publication (Tokkai-Hei) No. 7-97142, the fixed positions of the stoppers are manually adjustably changed depending on the vertical size of the bobbin. Thus, much time and effort is required to change a lot. Furthermore, the result of the adjustment based on the manual adjustably changing operation is likely to vary. Since the operation cylinder is used to elevate and lower the suction cylinder, the suction cylinder needs to be operatively moved at the same speed both during elevation and during lowering. This is inconvenient.

[0007] Furthermore, in the Unexamined Japanese Patent Application Publication (Tokkai-Hei) No. 7-97142, the cutter device is fixed to an upper part of one side of the machine body. Thus, the yarn end sucked into the cutter device is always cut at a constant position regardless of a change in the standby position of the suction cylinder, that is, a change in the vertical size of the bobbin. Thus, the length of the yarn resulting from the cutting by the cutter device may be excessively long or short. For example, the length of the yarn inserted into the winding core which length is appropriate to a bobbin with a large vertical size may be excessively large for a bobbin with a small vertical size. When the length of the yarn inserted into the winding core is excessively long or short, an automatic winder device for the subsequent step into which the bobbin is to be fed may fail to properly catch the yarn end. Then, the automatic winder device may operate improperly.

[0008] An object of the present invention is to provide a yarn end retrieving apparatus that enables the standby position of the suction cylinder to be automatically changed depending on the vertical size of the bobbin, thus allowing the setup of the yarn end retrieving apparatus to be easily and accurately changed in association with a lot change. An object of the present invention is to provide a yarn end retrieving apparatus that allows the movement speed of the suction cylinder to be set to be suitable for elevation and for lowering, thus enabling a reduction in the time required for a whole yarn end retrieving process. An object of the present invention is to provide a yarn end retrieving apparatus that allows the length of the yarn resulting from the cutting by the cutter device to be suitably set depending on a change in the

vertical size of the bobbin.

[0009] A yarn end retrieving apparatus comprises a yarn releasing device sucking and releasing a yarn end from a surface of a bobbin together with suction air, via a suction cylinder surrounding a periphery of the bobbin, a cutter device cutting the yarn sucked out by the yarn releasing device, a cylinder elevating and lowering device including a driving source elevating and lowering the suction cylinder between a standby position above the bobbin and a lowered position where the suction cylinder covers the surface of the bobbin, and a control means for controlling an elevating position and a lowering position for the cylinder elevating and lowering device. Thus, the cylinder elevating and lowering device operated by the control means holds the suction cylinder at a predetermined position.

[0010] The predetermined position where the position of the suction cylinder is held includes the standby position of the suction cylinder.

[0011] Another yarn end retrieving apparatus according to the present invention comprises a yarn releasing device sucking and releasing a yarn end from a surface of a bobbin together with suction air, via a suction cylinder surrounding a periphery of the bobbin, a cutter device cutting the yarn sucked out by the yarn releasing device, a cutter elevating and lowering device including a driving source elevating and lowering the cutter device, and a control means for controlling an elevating position and a lowering position for the cutter elevating device.

[0012] A sensor sensing shape of the bobbin with the yarn wound therearound is provided so as to be movable together with the suction cylinder.

[0013] A driving source elevating and lowering the suction cylinder and the driving source elevating and lowering the cutter device are each composed of a stepping motor.

[0014] In the present invention, the yarn end retrieving apparatus comprises the yarn releasing device, the cutter device, the cylinder elevating and lowering device including the driving source elevating and lowering the suction cylinder, and the control means for controlling the elevating and lowering positions for the cylinder elevating and lowering device. According to the yarn end retrieving apparatus, the cylinder elevating and lowering device operated by the control means enables the suction cylinder to be held at the predetermined position. Thus, an elevating and lowering speed and an elevating and lowering stroke for the suction cylinder can be freely set to hold the suction cylinder at the position corresponding to the bobbin to be processed. Thus, compared to conventional yarn end retrieving apparatuses requiring manual change and adjustment of the suction cylinder, the present yarn end retrieving apparatus allows the setup thereof to be quickly and easily changed in association with a lot change. Furthermore, simply by inputting bobbin data to the control means, the standby position of the suction cylinder can be automatically determined. Additionally, the suction cylinder can be held at the predeter-

mined position. When the standby position of the suction cylinder is to be changed, for example, an expected result of the change is displayed on a display device. Then, the expected result of the change can be understood to determine whether or not the change is acceptable.

[0015] When the predetermined position where the position of the suction cylinder is held includes the standby position of the suction cylinder, the standby position of the suction cylinder can be automatically changed depending on the vertical size of the bobbin. Thus, the standby position of the suction cylinder can be accurately changed in association with a lot change.

[0016] The alternative yarn end retrieving apparatus according to the present invention comprises the yarn releasing device including the suction cylinder, the cutter device cutting the yarn sucked out by the yarn releasing device, the cutter elevating and lowering device elevating and lowering the cutter device, and the control means for controlling the elevating and lowering position for the cutter elevating and lowering device. According to the yarn end retrieving apparatus including the cutter elevating and lowering device elevating and lowering the cutter device, a yarn cutting position can be optimized according to the vertical size of the bobbin. This enables elimination of excess or shortage of the yarn sucked into a winding core, allowing a winder to reliably catch the yarn. Furthermore, simply pre-inputting bobbin data to the control means allows the control means to automatically determine a vertical position of the cutter device so that the cutter elevating and lowering device can elevate and lower the cutter device to appropriate positions. Thus, the setup of the yarn end retrieving apparatus can be quickly and easily changed in association with a lot change.

[0017] When the sensor moving together with the suction cylinder can sense the shape of the bobbin with the yarn wound there around, whether the bobbin to be processed is a full bobbin, a half bobbin, or a smaller bobbin (a bobbin with a small amount of remaining yarn). This enables the suction cylinder to be elevated and lowered in a manner compatible with each bobbin. For example, with the half bobbin, the suction cylinder is quickly lowered from the standby position to a height position where the yarn is to be sucked and released and then lowered at a speed suitable for the suction and release. Thus, the waste of time associated with the elevation and lowering of the suction cylinder can be avoided.

[0018] When the driving source elevating and lowering the suction cylinder and the driving source elevating and lowering the cutter device are each composed of the stepping motor, the elevating and lowering speeds for the suction cylinder and the cutter device can be freely set. Therefore, the suction cylinder and the cutter device can be elevated and lowered efficiently to allow a displacement operation to be suitably performed. Furthermore, the suction cylinder and the cutter device can be accurately moved to the predetermined positions.

[0019] Other features, elements, processes, steps, characteristics and advantages of the present invention

will become more apparent from the following detailed description of preferred embodiments of the present invention with reference to the attached drawings.

BRIEF DESCRIPTION OF THE DRAWINGS

[0020]

Figure 1 is a schematic side view of a yarn end retrieving apparatus.

Figure 2 is a diagram illustrating sequential operations of the yarn end retrieving apparatus.

Figure 3 is a sectional view taken along line A-A in Figure 1.

DETAILED DESCRIPTION OF PREFERRED EMBODIMENTS

[0021] Figures 1 to 3 show an embodiment of a yarn end retrieving apparatus according to the present invention. In Figure 1, the yarn end retrieving apparatus has a vertically long machine body 2 located so as to face a conveying path for a bobbin 1, and a yarn releasing device 3 extending from an upper front portion of the machine body 2 to the interior of the machine body 2. The yarn releasing device 3 is composed of, for example, a fan 4 that generates a suction air flow, a suction pipe 5 connected to an inlet port of the fan 4, and a pair of nozzles 6 that blows compressed air against the bobbin 1. The suction pipe 5, located in the upper front portion of the machine body 2, is bent into an inverse L shape. A yarn sensing sensor 7 is located in an inner corner of the folded portion of the suction pipe 5. The bobbin 1 includes a winding core 8 with vertically opposite open ends. A lower end of the winding core 8 is supported on a conveying tray 9 provided along a conveying path.

[0022] A cutter device 10 cutting a middle part of a yarn Y sucked out by the yarn releasing device 3 is located at a lower end of the suction pipe 5 which projects forward in the machine body 2. An upper end of a flexible cylinder 12 that can be expanded and contracted in a vertical direction is fixed to a cylinder wall 11 that is continuous with a lower end of the cutter device 10. A suction cylinder 13 is connected to a lower end of the flexible cylinder 12. The cutter device 10 includes a cutter blade 14 and a driving structure (not shown in the drawings) for the cutter blade 14. The cutter blade 14 also functions as a shutter that blocks a suction air flow acting on the suction pipe 5. The cutter blade 14 having cut the middle part of the yarn Y can block the suction air flow.

[0023] The suction cylinder 13 is formed of a cylinder larger than the size of the diameter of a yarn layer on the bobbin 1. The suction cylinder 13 is elevated and lowered between a standby position and a lowered position by a cylinder elevating and lowering device 16 provided inside the machine body 2. The cylinder elevating and lowering device 16 is composed of a guide structure and a driving structure that elevates and lowers the suction cylinder

13 along the guide structure.

[0024] The guide structure is composed of a pair of guide shafts (guide members) 17 arranged side by side in a front-back direction, brackets 18 that fixedly support an upper end and a lower end, respectively, of each of the guide shafts 17, and a slider 19 that is slidably guided along both guide shafts 17 so as to be able to elevate and lower. As shown in Figure 3, the slider 19 is composed of slide blocks 20 slidably guided along the guide shafts 17, a coupling plate 21 that connects the slide blocks 20 together, and a coupling block 22 fixed to the coupling plate 21 between the slide blocks 20. The suction cylinder 13 is joined and fixed to the coupling plate 21 via a joining arm 23 projecting from an outer surface of the suction cylinder 13.

[0025] A driving structure is composed of a stepping motor 25 located above the upper bracket 18 and serving as a driving source. Specifically, the driving structure is composed of an upper pulley 26 fixed to an output shaft of the stepping motor 25, a pulley 27 rotatably supported by the lower bracket 18, and a driving belt 28 wound around both pulleys 26, 27. Both pulleys 26, 27 are composed of timing pulleys, and the driving belt 28 is composed of a timing belt. The driving belt 28 is located so as to sandwich the coupling plate 21 between an upper part and a lower part of the belt. As shown in Figure 3, one straight-line transition portion of the belt is fixedly clamped to the coupling block 22 of the slider 19 via a seat plate 29 by means of a bolt 30.

[0026] The driving belt 28 is located parallel to the guide shafts 17. The straight-line transition portions of the driving belt 28 enable the slider 19 to be drivingly elevated and lowered along the guide shafts 17. Thus, the suction cylinder 13 is elevated and lowered between the standby position (the position shown in Figure 1) above the bobbin 1 and the lowered position (the position shown in Figure 2B) where the suction cylinder 13 covers the surface of a lower part of the bobbin 1.

[0027] The suction cylinder 13 is held at the standby position at a given distance from the position of an upper end of the bobbin 1 depending on the vertical size of the bobbin 1. Specifically, size data on the bobbin 1 to be processed is pre-input to a control circuit (control means) 43. This determines the standby position of the suction cylinder 13. By counting the number of steps from a reference position taken by the stepping motor 25, the suction cylinder 13 can be held at an appropriate standby position.

[0028] A sensor 33 sensing the shape of the bobbin 1 with the yarn wound therearound is installed on the suction cylinder 13. The sensor 33 senses the external shape of the yarn layer on the bobbin 1 to enable determination of whether the bobbin 1 is a full bobbin 1 around which the yarn Y has been fully wound, a half bobbin 1 from which a part of the yarn layer has been unwound by the winder, or a smaller bobbin 1 with a small amount of remaining yarn layer.

[0029] Based on pre-input bobbin data, the control cir-

cuit 43 automatically determines the standby position of the suction cylinder 13. Concurrently, the cutter device 10 is elevated and lowered by the cutter elevating and lowering device 35. Thus, a cutting position for the yarn Y can be optimized. Here, the standby position of the suction cylinder 13 is slightly higher than a position corresponding to the vertical size (height dimension) of the bobbin 1, which is conveyed in an upright condition. When the standby position is set to be sufficiently higher than the position corresponding to the height dimension of the bobbin 1, all bobbins 1 can be dealt with. However, if the bobbin 1 to be processed has a small vertical size, an unwanted elevating and lowering operation needs to be performed, thus reducing efficiency. In general, the standby position of the suction cylinder 13 is set to be higher than the upper end of the bobbin 1 to be processed, by about 10 mm. The cutter elevating and lowering device 35 is composed of a stepping motor 36 fixed to the machine body 2, a feed screw shaft 37 rotationally driven by the stepping motor 36, and a female threaded member 38 elevated and lowered by the feeding screw shaft 37. An upper end of the feed screw shaft 37 is coupled to the stepping motor 36 via a coupling. A lower end of the feed screw shaft 37 is supported by a bracket 39 fixed to the machine body 2. The female threaded member 38 is fixed to a coupling frame 40 fixed to the lower end of the cutter device 10. The stepping motor 36 is started or stopped based on an instruction signal output by the control circuit 43.

[0030] In the cutter elevating and lowering device 35, when the feed screw shaft 37 is rotationally driven forward or backward by the stepping motor 36, the female threaded member 38 is displaced upward or downward to elevate or lower the cutter device 10. Thus, the cutting position for the yarn Y can be optimized depending on a change in the vertical size of the bobbin 1. The cutting position for the yarn Y is set such that the total length of the yarn Y sucked into the winding core 8 is slightly smaller than the vertical size of the bobbin 1. When the cutter device 10 is displaced so as to elevate or lower, the suction pipe 5 is displaced so as to elevate and lower together with the cutter device 10.

[0031] Now, an operation of the yarn end retrieving apparatus will be described. When the full bobbin 1 is conveyed to the vicinity of a yarn setup portion together with the conveying tray 9, a cut device provided on the left side of the yarn end retrieving apparatus in a conveying direction is activated to cut the yarn Y fixedly wound around an upper end or a lower end of the winding core 8. Thereafter, the bobbin 1 is conveyed to the front of the yarn end retrieving apparatus. Then, the conveying tray 9 is stopped and held by a stopper (not shown in the drawings). Moreover, a lower part of the bobbin 1 is pressed and held by a presser lever (not shown in the drawings). Then, as shown in Figure 1, compressed air is blown out from nozzles 6 to blow the yarn Y cut by the cut device to above the bobbin 1.

[0032] In the above-described condition, the cutter

blade 14 is operatively displaced to a cutting standby position. The cutter blade 14 blocking the suction pipe 5 is thus displaced to a passage open position. Consequently, the suction pipe 5 and the suction cylinder 13 communicate with each other via the cutter device 10 and the flexible cylinder 12 so that a suction air flow can act on the suction cylinder 13.

[0033] In this condition, the stepping motor 25 is started based on an instruction signal output by the control circuit 43. The suction cylinder 13 is lowered via the slider 19 at a predetermined speed. As the suction cylinder 13 lowers, an upward suction air flow acts on a peripheral surface of the bobbin 1. Thus, the yarn end being blown upward by air through the nozzles 6 is sucked into the suction pipe 5 via the suction cylinder 13, the flexible cylinder 12, and the cutter device 10 as shown in Figure 2B.

[0034] The sensor 7 senses that the yarn Y has been sucked into the suction pipe 5. Then, as shown in Figure 2C, the stepping motor 25 is reversely driven to return the suction pipe 13 to the standby position. However, if the yarn Y cannot be sensed by the sensor 7 even though the lower end of the suction cylinder 13 has reached the lower end of the bobbin 1, the suction cylinder 13 is returned to the standby position and then lowered again to suck the yarn using a suction air flow. The suction cylinder 13 attempts to suck the yarn a plurality of times. If the attempts have failed to allow the sensor 7 to output a signal indicating that the yarn Y has been sensed, the stopper for the conveying tray 9 is released to allow the bobbin 1 to be discharged from the yarn setup position.

[0035] After the yarn Y is sensed by the sensor 7 and the suction cylinder 13 then returns to the standby position, a middle part of the yarn Y unwound from the bobbin 1 is pressed and held against the peripheral surface of an upper part of the winding core 8 by a presser lever 44 (see Figure 2C). In this condition, the cutter device 10 is actuated to cut the yarn Y and to allow the cutter blade 14 to close the lower end of the suction pipe 5 to block the suction air flow. Concurrently with the driving of the cutter device 10, a shutter of a yarn sucking device 45 provided below the conveying tray 9 is opened. Thus, a downward suction air flow acts on the interior of the winding core 8 to suck the end of the cut yarn Y into the winding core 8 of the bobbin 1 as shown in Figure 2D. Finally, the presser lever 44 and the presser lever 44 pressing and holding the lower part of the bobbin 1 are operatively returned. Moreover, the stopper stopping and holding the conveying tray 9 is returned to the standby position. The conveying tray 9 is fed to the winder.

[0036] When the half bobbin is conveyed to the front of the yarn end retrieving apparatus, the conveying tray 9 is stopped and held, and the lower part of the bobbin 1 is pressed and held by the presser lever as described above. Moreover, compressed air is blown out from the nozzles 6 to blow the yarn Y to above the bobbin 1. At this time, when the sensor 33 senses that the bobbin to be processed is a half bobbin, the suction cylinder 13 is

lowered quickly to a winding position for the yarn Y. The suction cylinder 13 is then lowered at the predetermined speed as is the case of the full bobbin 1 with a suction air flow acting on the surface of the bobbin 1. Subsequently, the following operations are performed according to the above-described procedure: suction of the yarn Y into the suction pipe 5, cutting of the yarn by the cutter device 10, and insertion of the yarn Y into the winding core 8 by the yarn sucking device 45. With the smaller bobbin, the series of operations are similarly performed.

[0037] According to the yarn end retrieving apparatus configured as described above, simply by pre-inputting the bobbin data to the control circuit 43, the standby position of the suction cylinder 13 can be automatically determined. Furthermore, the suction cylinder 13 can be accurately held at the standby position by the cylinder elevating and lowering device 16. The standby position can be accurately changed in association with a lot change. Thus, compared to the conventional yarn end retrieving apparatuses requiring manual change and adjustment of the suction cylinder 13, the present yarn end retrieving apparatus allows the setup thereof to be quickly and easily changed in association with the lot change.

[0038] Furthermore, since the stepping motor 25 is used as a driving source, an elevating and lowering speed and an elevating and lowering stroke for the suction cylinder 13 can be freely set. For example, the speed at which the suction cylinder 13 is elevated and returned to the standby position can be set to be higher than that at which the suction cylinder 13 is lowered to suck out the yarn Y. The cylinder elevating and lowering device 16 configured as described above enable a reduction in the time required for the yarn setup process. If required, the suction cylinder 13 can be stopped and held at a predetermined height to allow the suction air flow to concentrate on the surface of the bobbin 1.

[0039] Furthermore, in the yarn end retrieving apparatus configured as described above, the cutting position for the yarn Y can be optimized in association with the vertical size of the bobbin 1 by allowing the cutter elevating and lowering device 35 to elevate and lower the cutter device 10 concurrently with the automatic setting of the standby position of the suction cylinder 13. Thus, with a bobbin 1 with a small vertical size, the end of the yarn Y sucked into the winding core 8 can be reliably prevented from being sucked into the yarn sucking device 45. For a bobbin 1 with a large vertical size, the yarn Y sucked into the winding core 8 is prevented from sticking out from the winding core 8 during the conveyance of the bobbin as a result of the insufficient length of the sucked yarn Y.

[0040] In the above-described configuration, the driving structure for the cylinder elevating and lowering device 16 is composed of the vertical pair of pulleys 26, 27, the driving belt 28, and others. However, this is not necessary. The driving structure can be composed of a feed screw shaft, a female threaded member, and others as in the case of the cutter elevating and lowering device 35. Furthermore, the driving structure and the cutter el-

evating and lowering device can be composed of a rack supported and guided so as to be slidable in the vertical direction, a pinion that drives the rack in the vertical direction, and a stepping motor that rotationally drives the pinion.

[0041] While the present invention has been described with respect to preferred embodiments thereof, it will be apparent to those skilled in the art that the disclosed invention may be modified in numerous ways and may assume many embodiments other than those specifically set out and described above. Accordingly, it is intended by the appended claims to cover all modifications of the present invention that fall within the scope of the invention.

Claims

1. A yarn end retrieving apparatus comprising:

a yarn releasing device (3) sucking and releasing a yarn end from a surface of a bobbin (1) together with suction air, via a suction cylinder (13) surrounding a periphery of the bobbin (1), a cutter device (10) cutting the yarn sucked out by the yarn releasing device (3), a cylinder elevating and lowering device (16) including a driving source elevating and lowering the suction cylinder (13) between a standby position above the bobbin (1) and a lowered position where the suction cylinder (13) covers the surface of the bobbin (1), and a control means (43) for controlling an elevating position and a lowering position for the cylinder elevating and lowering device (16), the yarn end retrieving apparatus being **characterized:**

in that the cylinder elevating and lowering device (16) operated by the control means (43) holds the suction cylinder (13) at a predetermined position.

2. The yarn end retrieving apparatus according to Claim 1, **characterized in that** the predetermined position where the position of the suction cylinder (13) is held includes the standby position of the suction cylinder (13).

3. A yarn end retrieving apparatus **characterized by** comprising a yarn releasing device (3) sucking and releasing a yarn end from a surface of a bobbin (1) together with suction air, via a suction cylinder (13) surrounding a periphery of the bobbin (1), a cutter device (10) cutting the yarn sucked out by the yarn releasing device (3), a cutter elevating and lowering device (35) including a driving source elevating and lowering the cutter device (10), and a control means (43) for controlling an elevating position and a low-

ering position for the cutter elevating device (35).

4. The yarn end retrieving apparatus according to Claim 2 or Claim 3, **characterized in that** a sensor (33) sensing shape of the bobbin (1) with the yarn wound therearound is provided so as to be movable together with the suction cylinder (13).

5. The yarn end retrieving apparatus according to Claim 4, **characterized in that** a driving source elevating and lowering the suction cylinder (13) and the driving source elevating and lowering the cutter device (10) are stepping motors (25, 36).

5

10

15

20

25

30

35

40

45

50

55

FIGURE 1

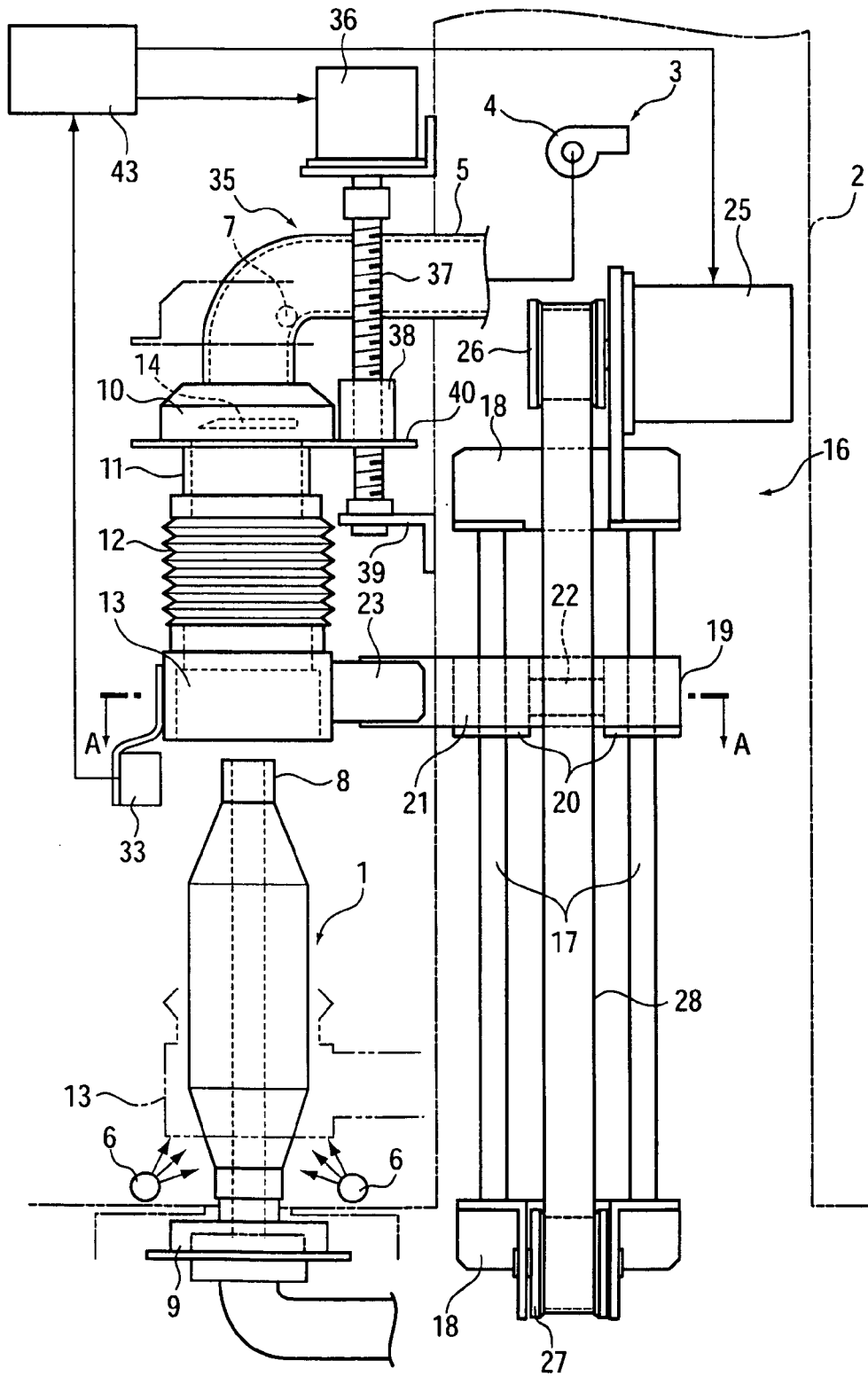

FIGURE 2D

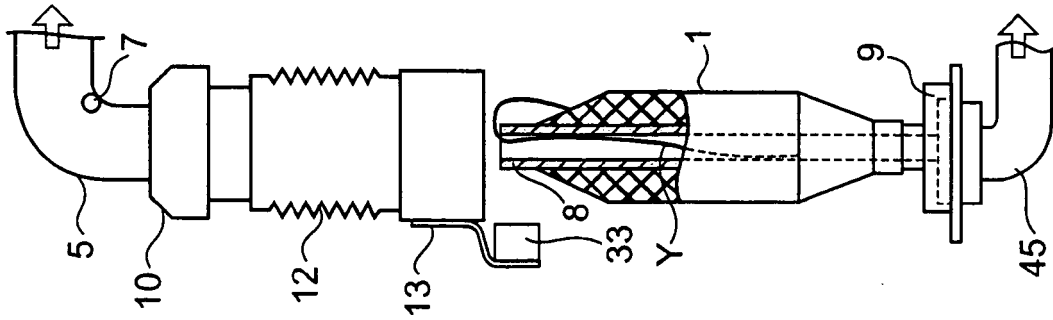

FIGURE 2C

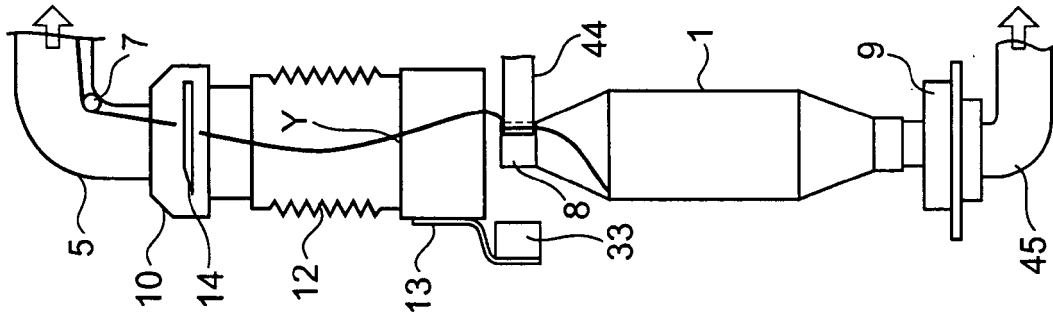

FIGURE 2B

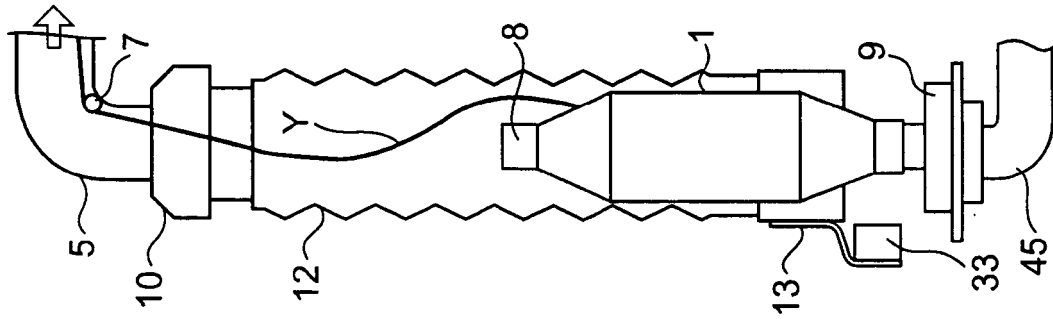

FIGURE 2A

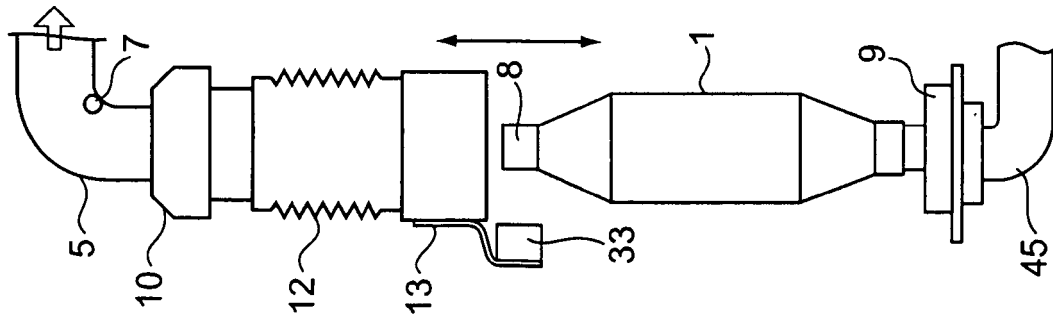
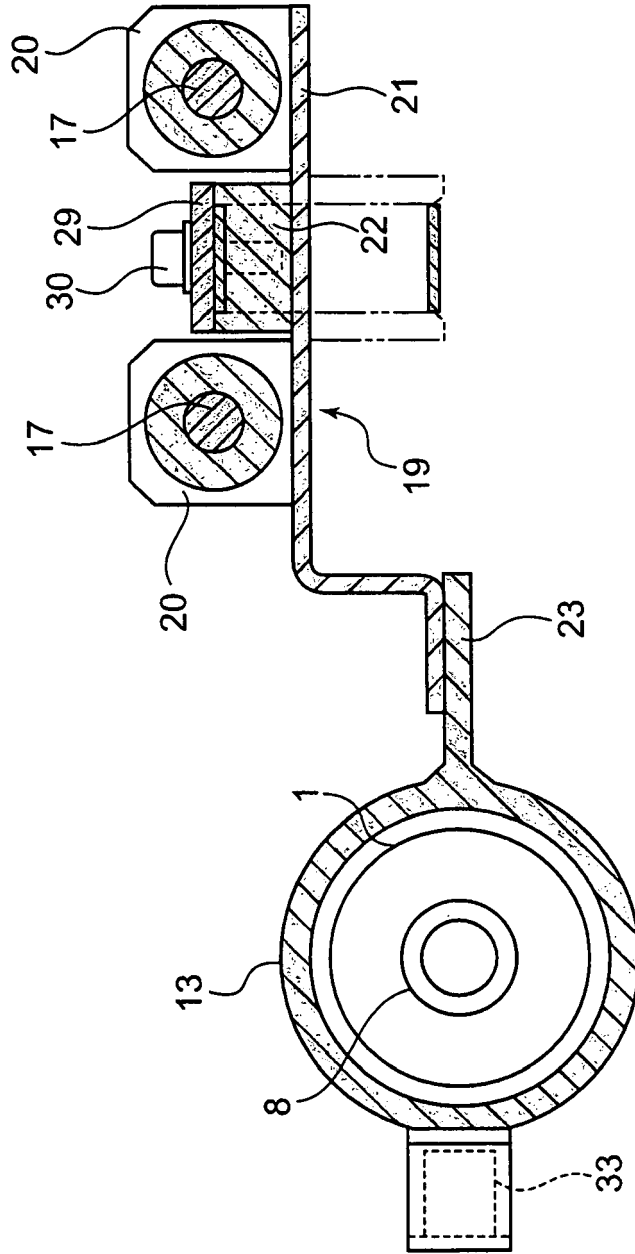

FIGURE 3



REFERENCES CITED IN THE DESCRIPTION

This list of references cited by the applicant is for the reader's convenience only. It does not form part of the European patent document. Even though great care has been taken in compiling the references, errors or omissions cannot be excluded and the EPO disclaims all liability in this regard.

Patent documents cited in the description

- JP 7097142 A [0002] [0005] [0006] [0007]
- JP 8324892 A [0004] [0004]