

(19) World Intellectual Property Organization
International Bureau



(43) International Publication Date
21 October 2010 (21.10.2010)

(10) International Publication Number
WO 2010/121076 A2

(51) International Patent Classification:

A61F 2/24 (2006.01) A61F 2/82 (2006.01)
A61M 29/00 (2006.01) A61F 2/84 (2006.01)

(21) International Application Number:

PCT/US2010/031313

(22) International Filing Date:

15 April 2010 (15.04.2010)

(25) Filing Language:

English

(26) Publication Language:

English

(30) Priority Data:

61/169,367 15 April 2009 (15.04.2009) US

(71) Applicant (for all designated States except US): **CARDIAQ VALVE TECHNOLOGIES, INC.** [US/US]; 1 Orient Street, Winchester, MA 01890 (US).

(72) Inventor: **QUADRI, Arshad**; 1 Orient Street, Winchester, MA 01890 (US).

(74) Agent: **DELANEY, Karoline, A.**; Knobbe, Martens, Olson & Bear, LLP, 2040 Main Street, 14th Floor, Irvine, CA 92614 (US).

(81) Designated States (unless otherwise indicated, for every

kind of national protection available): AE, AG, AL, AM, AO, AT, AU, AZ, BA, BB, BG, BH, BR, BW, BY, BZ, CA, CH, CL, CN, CO, CR, CU, CZ, DE, DK, DM, DO, DZ, EC, EE, EG, ES, FI, GB, GD, GE, GH, GM, GT, HN, HR, HU, ID, IL, IN, IS, JP, KE, KG, KM, KN, KP, KR, KZ, LA, LC, LK, LR, LS, LT, LU, LY, MA, MD, ME, MG, MK, MN, MW, MX, MY, MZ, NA, NG, NI, NO, NZ, OM, PE, PG, PH, PL, PT, RO, RS, RU, SC, SD, SE, SG, SK, SL, SM, ST, SV, SY, TH, TJ, TM, TN, TR, TT, TZ, UA, UG, US, UZ, VC, VN, ZA, ZM, ZW.

(84) Designated States (unless otherwise indicated, for every

kind of regional protection available): ARIPO (BW, GH, GM, KE, LR, LS, MW, MZ, NA, SD, SL, SZ, TZ, UG, ZM, ZW), Eurasian (AM, AZ, BY, KG, KZ, MD, RU, TJ, TM), European (AT, BE, BG, CH, CY, CZ, DE, DK, EE, ES, FI, FR, GB, GR, HR, HU, IE, IS, IT, LT, LU, LV, MC, MK, MT, NL, NO, PL, PT, RO, SE, SI, SK, SM, TR), OAPI (BF, BJ, CF, CG, CI, CM, GA, GN, GQ, GW, ML, MR, NE, SN, TD, TG).

Published:

— without international search report and to be republished upon receipt of that report (Rule 48.2(g))

(54) Title: VASCULAR IMPLANT AND DELIVERY SYSTEM

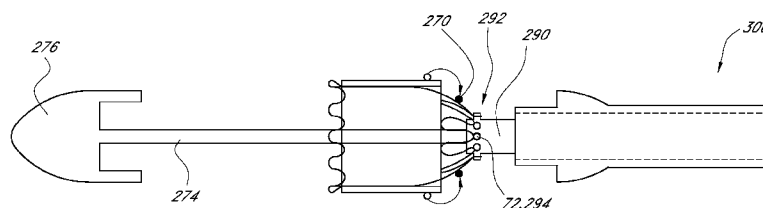

FIG. 15E

(57) Abstract: A vascular implant for replacing a native heart valve comprises a self expanding stent supporting a valve body having leaflets. The stent preferably comprises an anchoring structure configured to prevent the implant from passing through the valve annulus. For delivery, the implant is compacted within a delivery device and secured at one end. During delivery the implant is partially released from the delivery device, and positioning of the implant is verified prior to full release. The implant can be at least partially resheathed and repositioned if desired.



WO 2010/121076 A2

VASCULAR IMPLANT AND DELIVERY SYSTEM

CROSS-REFERENCE TO RELATED APPLICATIONS

[0001] This application claims priority to U.S. Provisional Application Serial No. 61/169,367, which was filed on April 15, 2009. The entirety of the Priority Application is hereby incorporated by reference. More particularly, paragraphs [0006]-[0008] and [00034]-[00046] and Figures 1-13 are incorporated by reference in connection with stent frame structure, and paragraphs [0009]-[00010] and [00047]-[00052] and Figures 14-19 are incorporated by reference in connection with delivery systems.

BACKGROUND

Field of the Invention

[0002] The present invention relates to replacement heart valves and systems for delivering replacement heart valves.

Description of the Related Art

[0003] Human heart valves, which include the aortic, pulmonary, mitral and tricuspid valves, function essentially as one-way valves operating in synchronization with the pumping heart. The valves allow blood to flow in a downstream direction, but block blood from flowing in an upstream direction. Diseased heart valves exhibit impairments such as narrowing of the valve or regurgitation. Such impairments reduce the heart's blood-pumping efficiency and can be a debilitating and life threatening condition. For example, valve insufficiency can lead to conditions such as heart hypertrophy and dilation of the ventricle. Thus, extensive efforts have been made to develop methods and apparatus to repair or replace impaired heart valves.

[0004] Prostheses exist to correct problems associated with impaired heart valves. For example, mechanical and tissue-based heart valve prostheses can be used to replace impaired native heart valves. More recently, substantial effort has been dedicated to developing replacement heart valves, particularly tissue-based replacement heart valves, that can be delivered with less trauma to the patient than through open heart surgery. Replacement valves are being designed to be delivered through minimally invasive procedures and even percutaneous procedures. Such replacement valves often include a

tissue-based valve body that is connected to an expandable stent that is then delivered to the native valve's annulus.

[0005] Development of replacement heart valves and associated delivery systems in which the heart valve is compacted for delivery and then controllably expanded for controlled placement has proven to be particularly challenging. Delivery systems that facilitate accurate positioning and reliable placement have also proven to be challenging to develop, particularly systems that enable repositioning of the valve after partial deployment if it is determined that the valve is not positioned correctly.

SUMMARY

[0006] Accordingly, there is in the need of the art for an improved replacement heart valve and an improved system for delivering such heart valves in a reliable and controlled manner.

[0007] In accordance with one embodiment, the present invention provides a method of loading a device for delivering a self-expanding vascular implant. The method may include drawing a relaxed, expanded vascular implant through an elongate form having a decreasing diameter to a load tube portion having a compacted diameter, engaging a locking end of the implant with a locking mechanism disposed on a support tube, advancing an outer sheath over the engaged locking end and support tube so as to capture the locking end between the sheath and support tube, and advancing the outer sheath over the compacted implant so as to transfer the implant from within the load tube to within the outer sheath.

[0008] In one such embodiment, transferring the implant from within the load tube to within the outer sheath comprises further compacting the implant.

[0009] In accordance with another embodiment, the present invention provides a vascular implant delivery device. The device comprises an elongate support tube having a distal end, a locking mechanism being disposed at or adjacent the distal end. An elongate sheath is adapted to slide over the support tube. A self-expanding vascular implant has a locking member. The support tube locking mechanism is configured to engage the implant locking member so as to block axial movement of the implant when the locking mechanism and locking member are engaged. The sheath has an inner lumen sized to block the implant

locking member from moving radially relative to the support tube locking mechanism sufficient to release from the support tube locking mechanism.

[0010] In one such embodiment, the self-expanding vascular implant remains connected to the support tube so long as the sheath extends distally past the support tube locking mechanism, and the device is configured so that when the sheath is moved proximally past the support tube locking mechanism, the implant locking member moves radially out of engagement with the support tube.

[0011] In accordance with yet another embodiment, the present invention provides a method of delivering a self-expanding vascular implant. The method may include advancing the implant within a patient's vasculature to a desired delivery location, the implant being advanced while maintained in a compacted configuration within a sheath, a first end of the implant being captured between the sheath and a support tube locking mechanism. The method further includes withdrawing the sheath proximally sufficient to enable a second end of the self-expanding implant to expand radially to a fully expanded size while the first end of the implant remains captured. The second end of the implant is positioned in a desired position and orientation while the first end of the implant remains captured. The method further includes withdrawing the sheath proximally sufficient to release the first end of the implant.

[0012] In once such embodiment, if it is determined that the second end of the implant is not positioned as desired, the method additionally comprises moving the sheath distally so as to at least partially recapture the implant within the sheath, repositioning the delivery device, and again withdrawing the sheath proximally sufficient to enable the second end of the implant to expand radially.

[0013] Other inventive embodiments and features are disclosed below.

BRIEF DESCRIPTION OF THE DRAWINGS

[0014] Figure 1 is a perspective view of a heart valve implant having features in accordance with one embodiment.

[0015] Figure 2A is a plan view of a stent frame of the implant of Figure 1 in a radially compacted configuration.

[0016] Figure 2B shows the stent frame of Figure 2A in a radially expanded configuration.

[0017] Figure 3 schematically shows an implant as in Figures 1-2 deployed in a native mitral annulus of a human heart.

[0018] Figure 4 is a plan view of a stent frame configured in accordance with another embodiment.

[0019] Figure 5 shows a flat cutting pattern for a stent frame as in Figure 4.

[0020] Figure 6 shows a plan view of a stent frame in accordance with yet another embodiment.

[0021] Figure 7 is a plan view of a stent frame configured in accordance with still another embodiment.

[0022] Figure 8 is a plan view of a stent frame configured in accordance with yet a further embodiment.

[0023] Figures 9A-E show exemplary embodiments of anchor portions for use with stent frame embodiments as discussed herein.

[0024] Figures 10A-D show exemplary embodiments of anchor tip portions for use with stent frame embodiments as discussed herein.

[0025] Figure 11A shows an embodiment of a delivery device for delivering a valve implant in accordance with one embodiment.

[0026] Figure 11B shows a distal portion of the delivery device of Figure 11A.

[0027] Figures 12A-I show a distal end of a delivery device at several stages during a delivery operation in accordance with a preferred embodiment.

[0028] Figures 13A-C show the delivery device of Figures 12A-I at selected stages of the deployment operation in connection with a human heart.

[0029] Figures 14A-L show an embodiment of a delivery device and an embodiment of a structure for loading an implant onto the delivery device, shown at several stages during a loading operation.

[0030] Figures 15A-H show another embodiment of a loading device and associated method shown at several stages during the operation of loading an implant onto a delivery device.

[0031] Figures 16A and 16B show an embodiment of a multi-piece loading device in an assembled and a disassembled configuration.

[0032] Figures 17A-F show another embodiment of a delivery device and an embodiment of a structure for loading an implant onto such a delivery device, shown at selected stages during a loading operation.

DETAILED DESCRIPTION OF PREFERRED EMBODIMENTS

[0033] The present specification and drawings disclose aspects and features of the invention in the context of embodiments of replacement heart valves and delivery systems for delivering replacement heart valves. For illustrative purposes the embodiments disclosed herein are discussed in connection with replacing the patient's mitral valve. However, it is to be understood that the context of a particular valve or particular features of a valve should not be taken as limiting, and features of any embodiment discussed herein can be employed in connection with prostheses and delivery systems for replacing other vascular valves, and features of any embodiment can be combined with features of other embodiments as desired and when appropriate.

[0034] With initial reference to Figures 1 and 2, an embodiment of a replacement heart valve 28 comprises a valve body 30 attached to a stent frame 40. In this embodiment, the heart valve body 30 is constructed of a tissue-based media such as bovine, equine and/or porcine pericardium. Vascular tissue, as well as other natural and manmade materials that are thin, flexible and durable, may also be employed for the heart valve body.

[0035] With particular reference to Figures 2A and 2B, the illustrated stent frame 40 embodiment supports the valve body 30 and can be expanded from a compacted state as shown in Figure 2A to an expanded state as shown in Figure 2B. The illustrated stent 40 preferably is a self-expanding stent constructed of a flexible material, preferably a shape memory material such as nitinol. As it is self-expanding, the stent 40 is in a fully opened state, as depicted in Figure 2B, when relaxed. The illustrated stent 40 preferably is elongate from a first end 42 to a second end 44 and is tubular with a longitudinal axis 46 and a generally circular cross section. It is to be understood that in other embodiments stents can have a non-circular cross section, such as a D-shape, an oval or an otherwise ovoid cross-sectional shape.

[0036] The illustrated stent frame 40 has a non-foreshortening portion 50 and a foreshortening portion 60. The portions are joined at a transition 62 between the first and second ends 42, 44. Foreshortening refers to a behavior in which the length of the stent 40 in the foreshortening portion 60 decreases as the radius of the stent increases from the compacted state to the expanded, deployed state. As such, in Figure 2A, which shows the stent frame 40 in a compacted state, the foreshortening portion 60 of the stent frame 40 is longer than when the stent is in the expanded state illustrated in Figure 2B.

[0037] With continued reference to Figure 2B, the non-foreshortening portion 50 of the illustrated stent 40 comprises a plurality of rows or rings 64a-c of circumferentially expandable elements, or struts 65, arranged in a zigzag pattern. The struts 65 are configured to expand and contract with a change in radius of the stent 40. In the illustrated embodiment, the stent has three such rings 64a-c. It is to be understood that more or fewer rings can be employed as desired to accomplish the purposes of this stent frame.

[0038] In the illustrated embodiment, the respective ends of each circumferential undulating strut 65 join an adjacent strut 65 at an apex 66, 68 which is, in at least some embodiments, an area of preferential bending. In the illustrated embodiment, the zigzag pattern of the rings 64a-c are generally in phase with one another. It is to be understood that, in other embodiments, all or most of the rings can be in phase with one another or out of phase as desired.

[0039] With continued reference to Figure 2B, longitudinal struts 70 extend transversely across the rings 64a-c of the nonforeshortening portion 50 from the first end 42 of the frame 40 to the transition 62. More particularly, each ring 64 shares a common longitudinal strut 70. The longitudinal struts 70 extend through apices 66 of adjacent rings 64, and preferably extend the entire length of the nonforeshortening portion 50. Preferably, the longitudinal struts 70 comprise a nonexpandable rod or bar. The apices 66 that are connected to the longitudinal struts 70 are referred to as "connected" apices 66. Apices 68 not connected to longitudinal struts 70 are referred to as "free" apices 68.

[0040] As noted above, the longitudinal struts 70 are not substantially expandable in a longitudinal direction. As such, even though the undulating struts 65 provide flexibility in radial expansion or compaction, as the stent 40 changes radial size between the compacted

and expanded states, the longitudinal length of the stent in the nonforeshortening portion 50 remains substantially unchanged. In other embodiments, the longitudinal struts may include expansible elements that may allow the struts to expand somewhat longitudinally. However, such longitudinal expansion would not be directly tied to any change in strut radius.

[0041] In the illustrated embodiment, a first ring 64a is disposed adjacent the first end 42 of the stent and a second ring 64b is disposed adjacent the first ring 64a. A set of first eyelets 72 is formed at the connected apices 66 of the second ring 64b. A set of second eyelets 74 is also formed at the second ends of each longitudinal strut 70, which in the illustrated embodiment is also at the transition 62. In a third ring 64c, the free apices 68 each comprise a protuberance 80 extending therefrom, which protuberance can also be referred to as an apical anchor 80. Preferably the apical anchor 80 terminates at a tip 82. Preferably the struts 65 in the third ring 64c are pre-shaped so as to flare radially outwardly when the stent frame 40 is in an expanded state as shown in Figures 1 and 2.

[0042] With continued reference to Figures 2A and 2B, the foreshortening portion 60 of the illustrated stent frame 40 comprises a ring 84 of generally diamond-shaped cells 86 connected to one another at connectors 88. A first end of each cell 86 is connected to the nonforeshortening portion 50 at the second eyelets 74. The shape of the foreshortening cells 86 is such that as the stent frame 40 is radially compacted, the foreshortening portion 60 of the stent becomes longitudinally longer and, correspondingly, when the stent frame 40 is expanded radially, the foreshortening portion 60 shortens.

[0043] A second end of each cell 86 in the foreshortening portion 60 defines the second end 44 of the stent 40 and also defines a base of an end anchor 90 that extends generally radially outwardly and toward the first end 42 of the stent. An anchor eyelet 92 is formed in each end anchor 90, preferably between the base and a tip 94 of each anchor 90.

[0044] A first distance is defined between the tips 82, 94 of opposing apical and end anchors 80, 90 when the stent 40 is in the compacted state, and a second distance is defined between the tips 82, 94 of opposing anchors 80, 90 when the stent 40 is in the expanded state. As shown, the second distance is substantially less than the first distance. As such, due to longitudinal shortening of the foreshortening portion 60, the anchors 80, 90 cooperate to grasp onto tissues so as to hold the stent in place.

[0045] In preferred embodiments, the stent 40 may be deployed into a heart valve annulus, and positioned when compacted so that the tips 82, 94 of the opposing anchors 80, 90 are disposed on opposite sides of the native annulus. As the stent is expanded, the opposing anchors are drawn closer together so as to grasp opposite sides of the native annulus and securely hold the stent in position. As such, the stent can be held securely in position without requiring a substantial radial force against the native annulus.

[0046] Applicant's copending U.S. Patent Application Serial No. 12/084,586, which was published on August 27, 2009 as U.S. Publication No. 2009/0216314, discusses embodiments of foreshortening stents with anchors, and can be referred to for further discussion of certain aspects of the illustrated stent embodiment. The discussion in this copending application concerning structure and operation of embodiments of a foreshortening stent, particularly a foreshortening stent having anchors, is expressly incorporated by reference herein.

[0047] Applicant's copending U.S. Patent Application Serial No. 12/569,856, which was published on April 1, 2010 as U.S. Publication No. 2010/0082094, discusses several additional embodiments of stents and associated valve bodies, and can be referred to for further explanation and discussion of additional features and embodiments thereof. The entirety of this copending application is also expressly incorporated by reference herein.

[0048] With particular reference again to Figure 1, in this embodiment the valve body 30 is disposed inside the stent 40. More specifically, a skirt portion 96 of the valve body 30 is sewn to the first eyelets 72 of the stent. A hemmed upstream end of the valve body 30 engages the first eyelets 72 in the nonforeshortening portion 50 of the stent 40. Valve leaflets are attached to the skirt portion and are configured to open and close during valve operation.

[0049] An elongate tubular portion 102 of flexible, longitudinally expandable fabric is attached to a downstream end 104 of the skirt portion 96 in the illustrated embodiment. More particularly, a first end of the fabric 102 is sewn to the downstream end 104 of the skirt portion about the circumference of the skirt portion by a downstream seam, which also connects to the second eyelets 74 of the stent frame 40. Preferably, the

fabric 102 is also sewn to the foreshortening cells 86 at several points by connector stitches 106.

[0050] In the illustrated embodiment, the fabric 102 curves around the second end of the stent frame 40, generally following the curvature of the end anchors 90. A second end of the fabric portion 102 is sewn to the anchor eyelets 92. Preferably, the flexible fabric 102 is sufficiently expandable to move with the foreshortening portion 60 as the stent 40 moves between the compacted state and the deployed, relaxed expanded state. As such, in the illustrated embodiment, the tissue valve body 30 is confined to the nonforeshortening portion 50 of the stent and the flexible fabric 102 spans the foreshortening portion 60 of the stent. Thus, the tissue valve body 30 is not subject to longitudinal expansion and contraction with the stent 40.

[0051] With reference next to Figure 3, a schematic representation of the heart valve 28 as discussed above in connection with Figures 1 and 2 is depicted installed in a human heart 110. The heart is shown in cross-section, and represents typical anatomy, including a left atrium 112 and left ventricle 114. The left ventricle 114 is defined by a muscular wall 116. The left atrium 112 and left ventricle 114 communicate with one another through a mitral annulus 120. Also shown schematically in Figure 3 is a native anterior mitral leaflet 122 having chordae tendinae 124 that connect a downstream end of the anterior mitral leaflet 122 to the muscle wall 116 of the left ventricle 114. A left ventricle outflow tract 126 extends toward the top of the left ventricle 114.

[0052] As shown in Figure 3, the valve 28 of Figures 1 and 2 is disposed so that the mitral annulus 120 is grasped between the end anchors 90 and apical anchors 80 in accordance with a method of aligning and deployment of the stent 40 discussed previously. As such, all or most of the stent 40 extends into the left atrium. The portion of the stent 40 disposed upstream of the annulus 120 can be referred to as being positioned supra-annularly. The portion generally within the annulus 120 is referred to as positioned intra-annularly. The portion downstream of the annulus is referred to as being positioned sub-annularly. In the illustrated embodiment, only a part of the foreshortening portion is positioned intra-annularly or sub-annularly, and the rest of the stent 40 is supra-annular.

[0053] In the illustrated embodiment, the anterior mitral leaflet 122 has not been removed prior to deploying the replacement valve 28. Preferably, the posterior mitral leaflet (not shown) also has not been removed prior to deploying the replacement valve. However, in other embodiments, one or both of these natural valve leaflets may be removed before deploying the replacement valve.

[0054] With reference next to Figure 4, another embodiment of a stent frame 140 is illustrated. The stent frame 140 is elongate and has opposing first and second ends 142, 144. A first circumferential ring 164a comprising undulating struts is arranged adjacent the first end 142. A second circumferential ring 164b of undulating struts is disposed adjacent the first circumferential ring 164a. A circumferential foreshortening ring 184 comprised of interconnected generally diamond-shaped foreshortening cells 186 is disposed generally adjacent the second end 144. A plurality of longitudinal struts 170 extend from the first end 142 toward the second end and terminate at a connection to corresponding foreshortening cells 186. Preferably, the longitudinal struts 170 pass through the undulating rings 164 and connect to apices of the rings 164. Preferably a locking member is formed on each longitudinal strut 170 at the first end 142. In the illustrated embodiment the locking members comprise eyelets. 72.

[0055] Anchors 190 extend from the foreshortening cells 186 at the second end 144 of the stent. In the illustrated embodiment, the anchors are bent so as to be directed generally toward the first end 142 and generally radially outwardly.

[0056] The elongate portion of the stent 140 through which the longitudinal struts extend is a nonforeshortening portion 150. The elongate portion of the stent made up of the foreshortening cells comprises a foreshortening portion of the stent. An elongate portion of the stent between the undulating rings 164 and the foreshortening ring 184 is referred to as a transition portion 194.

[0057] In a manner as discussed above in connection with other embodiments, when the stent 140 is radially compacted, the length of the longitudinal section will remain substantially constant, but the length of the foreshortening portion will increase. Correspondingly, when radially expanded from a compacted state to the expanded state as

shown in Figure 4, the length of the foreshortening portion will decrease, while the length of the nonforeshortening portion remains the same.

[0058] The stent frame 140 is configured to support a flexible valve body having valve leaflets so as to provide a prosthetic heart valve implant. Preferably the valve body is disposed on the inside of the stent frame. This specification presents multiple stent frame embodiments, which can support valve bodies of multiple shapes and configurations so as to provide valve implants. For ease of illustration, this specification and associated drawings will refer to a stent or implant without necessarily discussing or showing the valve body. However, it is to be understood that valve implants are to include a valve body having leaflets.

[0059] In the illustrated embodiment, each of the longitudinal struts bends radially inwardly in the transition portion 194 between the second ring 164b and the foreshortening ring 184 so as to define a shoulder 192 along which the outer diameter of the stent lessens. As such, and as shown in Figure 4, the diameter of the stent at the first end 142 is greater than the diameter of the stent 140 at the second end 144 when the stent is in the relaxed position. In the illustrated embodiment, the anchors 190 extend radially outwardly sufficient so that tips of the anchors are disposed diametrically about the same as or outwardly from the shoulder.

[0060] In a preferred embodiment, the stent frame is initially provided as a circular cross-section nitinol tube. The tube is laser cut according to a pattern corresponding to the struts, cells and the like. The cut tube preferably is electrochemically polished to as to remove rough edges. The cut and polished nitinol tube may be shaped in accordance with a desired manner, such as shaping the anchors to extend radially outwardly, and the nitinol stent frame may be heated-treated to both establish the shape memory and to obtain desired elasticity attributes.

[0061] With specific reference to Figure 5, a flat pattern for laser cutting a nitinol tube to form the stent 140 of Figure 4 is shown. As indicated, the rings 164 are formed near a first end of the flat pattern and the anchors 190 formed are at an opposite second end of the flat pattern. The rings 164 include the cuts for the undulating struts, and the foreshortening ring 184 includes the cells 186 in a flat configuration. The transition area 194 is shown

between the undulating rings 164 and the foreshortening ring 184. Although the stent is initially cut to the pattern shown in Figure 5, further shaping and manipulation is performed to form it into the shape shown in Figure 4. For example, the stent as a whole is stretched radially, the anchors 190 are bent backwardly, and the longitudinal struts 170 in the transition portion are deformed to form the shoulders 192. The stent is then heat treated, as appropriate, so as to take on the illustrated desired shape as its relaxed shape.

[0062] In the embodiment illustrated in Figure 4, there is no outwardly-extending anchor barb upstream from the anchors 190. Preferably, in practice, the stent 140 is placed so that the valve annulus is captured between the anchors 190 and the shoulder 192. As such, the shoulder 192 and anchors 190 cooperate to hold the stent 140 in place, preventing the stent from being forced either way through the native annulus.

[0063] With reference next to Figure 6, another embodiment of a stent 140a is shown, having structure similar to the stent 140. However, in the transition portion 194 of stent 140a, the longitudinal struts 170 bend along their length to extend radially outwardly, and then bend again to extend radially inwardly so as to define an outward flare 196. In the illustrated embodiment, at least portions of the undulating struts 65 of the second undulating ring 164b take on the curvature of the at least part of the flare 196.

[0064] In a manner similar to the embodiment of Figure 4, the flare portion 196 of the transition portion 194 effectually creates a shoulder 192. However, in the stent 140a embodiment illustrated in Figure 6, the diameter at the first end 142 of the stent 140a is substantially the same as the diameter of the stent at the second end 144. Preferably, and in a manner having similarities to the discussion above, during valve deployment, the native valve annulus will be captured in the area between the anchors 190 and the shoulder 192. In a preferred embodiment, the flat cut pattern as illustrated in Figure 5 can be formed into the shape of stent 140a. Thus, multiple stent shapes can be formed from the same cut pattern.

[0065] With reference next to Figure 7, yet another embodiment of a stent 140b has a structure much like that of stent 140. However, as shown, an upstream anchor 190b extends from each of the free apices 118 of the second ring 164. Preferably the upstream anchors 190b extend distally past the initial bend of the shoulder 192. In this embodiment,

during valve deployment, a native annulus preferably is captured between and engaged by the anchors 190, shoulders 192 and upstream anchors 190b.

[0066] With reference next to Figure 8, still another embodiment of a stent 140c having basic structure very similar to stent 140 of Figure 4 is illustrated. In the illustrated embodiment, the longitudinal struts 170 bend in a transition portion 194 so as to define a shoulder 192. However, as shown in the illustrated embodiment, at or near the beginning of the inward radial bend, the longitudinal struts each split into three arms 198a, 198b, 190c. First and second arms 198a, b cooperate to define a cell which preferably extends the length of the shoulder 192 from the point of bending to a foreshortening cell 186 of the foreshortening ring 184. A third arm 190c between the first and second arms 198a, b extends from the bend portion toward the second end 144 of the stent 140c and radially outwardly so as to define a strut anchor 190c generally opposing the corresponding downstream anchor 190. In a manner similar to other embodiments discussed above, during valve placement, preferably a native valve annulus is captured in the space between the downstream anchor 190 and the strut anchor 190c. The stent 140c is held securely in place by the opposing anchors 190, 190c, and shoulder 192.

[0067] In the embodiments discussed above, stent frames have been described in which upstream end of the stent has a diameter greater than a downstream end of the stent, and embodiments have been described in which the upstream and downstream ends have substantially the same diameter. It is also to be understood that other stent embodiments may have a downstream end having a greater diameter than an associated upstream end.

[0068] In the stent frame embodiments discussed above, the stents are cut from a tube having similarities to the embodiment shown in Figure 5, and the anchors are formed during processing by bending the anchor portions backwardly and radially outwardly. It should be understood that a plurality of anchor shapes may be employed as desired. For example, with reference next to Figure 9A, one embodiment of an anchor 90a comprises a relatively large base radius having a generally "U"-shaped bend. Figure 9B shows an anchor 90b also having a relatively large base radius but then continuing bending about the radius beyond 180° so as to define a bulged feature before bending again so as to extend toward the first end of the stent. Figure 9C presents an anchor 90c having a relatively tight base radius

leading to an outward bend and then another bend back inwardly so that the anchor tip is directed generally parallel to or slightly outwardly from a longitudinal axis of the stent. Figure 9D illustrates an anchor 90d with a relatively large base radius leading to an outward bend before bending back inwardly so that the anchor tip is directed generally parallel to or slightly outwardly from a longitudinal axis of the stent. Figure 9E shows an anchor 90e having a tight base radius that completes only about a 130°-160° turn, and then continues to curve slightly along its length having a very long bending radius so as to approach, but not necessarily complete, a 180° turn at its tip.

[0069] In the illustrated embodiment, the tips of the anchors have been shown as generally pointed or flat. It is to be understood that numerous tip configurations can be employed as desired to optimize the engagement and attachment of the replacement heart valve to the native valve annulus. For example, Figure 10a shows an anchor tip 92a having a smooth radius configured to limit trauma to the tissue. Figure 10b illustrates an embodiment of an anchor tip 92b having an expanded ball radius. Such a ball radius can be created as a two-dimensional circular shape during the laser cutting process, or can be a three-dimensional sphere attached to the anchor tip during, for example, a ball welding procedure. Figure 10c shows a pointed anchor tip 92c configured to provide some degree of penetration into the tissue of the valve annulus. Figure 10d illustrates a flared anchor tip 90d configured to distribute anchor forces over a surface area of tissue, but also comprising a serrated edge to penetratingly engage such tissue. In additional embodiments a flared tip may have a smooth edge. Additionally, further tip configurations can be employed as desired to optimize engagement and fixation for different valves and different disease morphologies. In further embodiments, different tip configurations can be combined within a single stent frame.

[0070] The embodiments as disclosed above in connection with replacement heart valves can be delivered to a patient's heart valve annulus in various ways, such as by open surgery, minimally-invasive surgery, and percutaneous, or transcatheter, delivery through the patient's vasculature. With reference next to Figures 11A and 11B, an embodiment of a delivery device 200 is shown in connection with a replacement heart valve. The illustrated embodiment comprises an elongate, steerable delivery catheter configured to be advanced through a patient's vasculature in a percutaneous delivery approach. The illustrated device

200 comprises an elongate inner tube 202 that is attached at its distal end to a nose cone 204. The inner tube 202 has a lumen sized and configured to slidably accommodate a guidewire 206 so that the device 200 can be advanced over the guidewire 206 through the vasculature. A support tube 208 concentrically encircles the inner tube 202 and is sized to be slidable over the inner tube. An outer sheath 210 is disposed so as to be slidable over the support tube 208. In the illustrated embodiment, and preferably, in a manner as discussed in embodiments presented below, the support tube 208 and outer sheath 210 cooperate to grasp onto an end of the replacement heart valve, which, for ease of illustration, is here represented by showing only a stent frame. For delivery, the valve is compacted and held within the outer sheath 210.

[0071] With reference next to Figures 12 and 13, delivery device 220 configured in accordance of one embodiment is shown at various steps along a sequence or method of valve implant deployment. More specifically, Figures 12A-12I demonstrate schematic views of various steps of a deployment process, and Figures 13A-13C show the state of the delivery device 220 relative to a native heart valve annulus 120 at certain stages of deployment. In the embodiment illustrated in Figure 13, the deployment device 220 deploys the heart valve implant 222 into a patient's native mitral annulus 120. It is to be understood, however, that features and aspects as discussed herein may be employed when employing valves elsewhere in a patient's heart or other vasculature.

[0072] With specific reference to Figure 13A, in use preferably the delivery device 220 is advanced into the patient's heart 110 so that a distal end including a nose cone 224 passes through the diseased native valve and through the native annulus 120. As such, the delivery device 220 preferably is positioned so that the anchor portions 226 of the valve implant 222, though still compacted within an outer sheath 230, are disposed generally on a side of the native annulus opposite an approach direction. Once the delivery device 220 is in place, and as next depicted in Figure 12A, the outer sheath 230 begins to be retracted thereby exposing the distal, or anchor end 232, of the valve implant 222. In the illustrated embodiment, barb-shaped anchors 226 are disposed at the anchor end 232. It is to be understood that other embodiments may employ other anchor structures. As the outer sheath 230 continues to be retracted as shown in Figure 12B, more of the stent 222 is exposed and

the anchor end of the stent begins to expand radially as progressively shown in Figures 12B, C and D. However, and as more particularly shown in Figure 12D, a proximal end 234 of the stent frame 222 is still held securely within the outer sheath 230, preferably by the outer sheath cooperating with a support tube so as to restrain the proximal end 234 of the stent 222 from being released from the delivery device 220. Nevertheless, since the distal portion 232 of the stent has been substantially released it is free to expand and, in the embodiment shown in Figure 12D, the distal end 232 of the stent can expand to its fully expanded state while the proximal end of the stent remains restrained within the outer sheath.

[0073] With additional reference now to Figure 13B, when the distal end 232 is fully expanded a slight back pressure preferably is applied to the entire delivery device 220 so as to pull the stent 222 proximally and seat the implant 222 and particularly the anchor features 226, against the native annulus. In the illustrated embodiment, the anchor features 226 are seated against the subvalvular side of the initial annulus 120. Proper seating of the implant can be confirmed via tactile feedback, external imaging, and/or other suitable methods.

[0074] With continued reference to Figures 12 and 13, if, for example, data indicates that the placement of the stent frame 222 should be modified, such as due to improper seating, alignment, engagement or the like. The implant 222 can be at least partially resheathed and repositioned. For example, with particular reference to Figures 12E and 12F, since the implant has not been fully deployed from the outer sheath 230, the outer sheath 230 can be moved distally, thus engaging and compacting the stent frame so as to force it back into the outer sheath. Such compaction will remove the implant 222 from its faulty positioning. The implant can then be repositioned and redeployed in a new position by again moving the outer sheath 230 proximally as depicted in Figure 12G.

[0075] Once it is determined that the implant 222 is correctly seated, with the anchors 226 disposed as desired in the subvalvular side of a native annulus, the implant can be completely released from the delivery device 220. Preferably, and with reference next to Figure 12H, such complete release comes when the outer sheath 230 continues to be retracted proximally, exposing the proximal end 230 of the stent frame 222 and disengaging the locking mechanism between the stent frame, support tube and outer sheath. As such, the

entire stent becomes free of any constraint by the delivery device and expands freely as depicted in Figures 12I and 13C so that the implant is fully deployed at the native annulus.

[0076] As shown in Figure 13C, preferably a foreshortening portion of the stent 222 is generally aligned with the native annulus 120 so that the annulus is captured between the anchor features 226 and an opposing anchor feature such as a shoulder portion of the stent. Of course, in other embodiments, other configurations of anchoring portions may or may not include a shoulder, may include upstream and downstream anchors, and/or may include other structure for engaging one or both sides of an annulus. Once the implant is fully deployed, preferably the sheath is again moved distally to re-engage the nose cone, and the delivery device is removed from the patient.

[0077] In the embodiment discussed and illustrated in connection with Figures 12 and 13, only a distal portion of the delivery device 220 is shown. It is to be understood that such a distal portion may be employed in multiple delivery device configurations. For example, a percutaneous, transcatheter-approach delivery device such as shown in Figures 11A and 11B can employ a distal portion similar to that in the embodiment shown in Figures 12 and 13. Also, delivery devices for use in minimally-invasive or even open surgical procedures may have similar structure and similar operation principles although such devices may advantageously have some different mechanical properties such as increased stiffness, than do embodiments used in trans-catheter approaches.

[0078] With reference next to Figures 14A-14L, an embodiment of a delivery device 238 and a method and apparatus for loading a heart valve implant 128 onto the delivery device is shown. With reference first to Figure 14A, the loading apparatus comprises a compacting device 240 which, in the illustrated embodiment, is generally funnel-shaped. The funnel 240 is elongate and comprises a first and second end 242, 244. The first end 242 has a comparatively large diameter and the second end 244 has a comparatively small diameter. A transition 246 progressively decreases the diameter between the first and second ends. Preferably, an elongate compaction portion 250 is disposed at and adjacent second end 244. Preferably, the diameter within the compacted portion 250 is generally constant along its length and approaches or matches the diameter of the second end 244.

[0079] A cap 252 is provided and is shaped to fit through the first or large end 242 of the funnel 240. Preferably an outer surface of the cap 252 is configured to fit generally complementarily against the inner surface of the funnel 240. A first end 254 of the cap 252 is configured to fit generally onto and hook onto the first end 242 of the funnel. A second end 256 of the cap 252 is configured to fit within the funnel and preferably proximal of the compacting portion 250 of the funnel 240. The second end of the cap preferably comprises a blocking structure.

[0080] With continued reference to Figure 14A, an example heart valve 128 is shown. In the illustrated embodiment, the heart valve comprises the stent frame 140 described above in connection with Figure 4. To aid in simplicity of illustration, only the stent frame, and not the valve body, is shown. It is to be understood, however, that in practice preferably a completely assembled heart valve implant is employed. Additionally, it is to be understood that implants and stents having configurations other than the specifically shown implant can make use of a compacting apparatus and delivery device having features in accordance with the features and principles discussed in connection with this embodiment. However, this structure and method are particularly preferred in connection with implants having self-expanding stents.

[0081] As shown in Figure 14A, preferably, the first end 242 of the funnel 240 has a diameter large enough to accommodate the fully expanded, at rest stent frame 140. Further, preferably, the stent frame is positioned so that its first end 142, at which the locking members 72 are disposed, is facing toward the funnel. In the illustrated embodiment, the locking members comprise eyelets. Other structures may be employed in other embodiments.

[0082] A pull member 260 or "octopus" preferably comprises a pull ring 262 that is connected to a plurality of elongate arms 264. Each of the arms preferably terminates in a hook 266 or other securing member that is configured to engage one of the locking members/eyelets 72. Preferably, there are the same number of arms 264 as there are eyelets 72. Additionally, preferably the arms are substantially flexible so as to appropriately distribute forces and to obtain secure purchase on the stent frame. In one embodiment, the arms 264 comprise a suture material, although various types of string and even semi-rigid plastics, wires or the like may be employed.

[0083] With additional reference to Figure 14B, an O-ring 270 is preferably disposed about the compacting portion 250 of the funnel 240 and generally adjacent the second end 244 of the funnel. In the illustrated embodiment, the O-ring 270 is an inwardly biased broken ring shape having a pair of tabs 272 adjacent the break in the ring. The tabs assist in placing the ring over the compacting portion 250 of the funnel and other side manipulating the O-ring. Preferably, the O-ring 270 is configured so that its at-rest position is at a diameter substantially less than the diameter of the compaction portion.

[0084] With reference next to Figure 14C, in operation preferably the octopus arms 264 are threaded through the open second end 244 of the funnel, out the first end 242 of the funnel, and engaged with the implant 128 so that each octopus hook 266 connects to one of the eyelets 72, on the stent frame 140. The pull ring 262 is then pulled so as to pull the implant into and through the first end of the funnel. As the pull ring continues to be pulled distally, the stent engages the inner surface of the funnel at the transition 246 and is forced to be radially compacted as the stent 140 is pulled through the funnel 240 until it is substantially compacted within the compaction portion 250 of the funnel and with the locking members 72 of the stent frame extending out of the second end of the funnel as shown in Figure 14D.

[0085] With continued reference to Figure 14D, once the implant has been pulled into the compaction portion 250 of the funnel so that the locking member portions of the frame are exposed and extend out of the second end of the funnel, the cap 252 preferably is inserted through the first end of the funnel so that its second end 256 is generally adjacent the second end 144 of the stent frame. The blocking structure at the second end of the cap 252 preferably is configured to prevent the stent frame from moving backwards out of the funnel. For example, the cap may have a thickness that substantially blocks such backwards movement. Other structures such as partial or full blocking of the funnel may also be employed. With the cap in place, the octopus arms are disengaged from the locking members as shown in Figure 14E.

[0086] With reference next to Figure 14F, additional structure of the delivery device is illustrated in connection with the funnel 240 and implant 128 in the configuration of Figure 15E. As shown, the delivery device 238 comprises an elongate inner tube 274 that is connected to a nose cone 276. Preferably, the inner tube 274 has a lumen sized and adapted

to accommodate a standard guidewire 278 extending therethrough. The nose cone 276 preferably has a generally atraumatic tip portion 280 at its distal end and has a cavity 282 formed in its proximal end. A circumferential skirt 284 extends from the proximal end of the nose cone 276 and an inner surface 286 of the circumferential skirt 284 defines the cavity 282.

[0087] An elongate support tube 290 has a lumen sized and configured to slidably accept and slide over the inner tube 274. A locking mechanism 292 comprising a plurality of locking features 294 is disposed adjacent a distal end of the support tube 290. In the illustrated embodiment, the locking features comprise bosses 294 extending radially outwardly from an outer surface of the support tube. The illustrated bosses 294 are sized and shaped to generally matingly fit the eyelets of the stent frame 140.

[0088] An outer sheath 300 is configured to fit slidably over the support tube 290. The outer sheath 300 has a thickness defined between an outer surface 302 and an inner surface 304. A diameter of a lumen of the outer sheath is defined by the inner surface 304 and preferably the lumen diameter 75 such that the inner surface just clears the locking bosses 294 of the support tube, as will be discussed and shown in more detail below. A raised portion 306 of the outer sheath 300 is disposed near but spaced from a distal end of the outer sheath, and a seat 308 is defined on the distal end of the raised portion 306. As will be discussed in more detail below, the raised portion and seat 308 are configured to engage a proximal end of the nose cone circumferential skirt 284.

[0089] Although the delivery device has just been introduced in connection with Figure 14F, it is to be understood that, in some embodiments, the funnel is threaded over the delivery device so that the funnel concentrically surrounds the inner tube and is disposed between the nose cone and the support tube before the heart valve implant is loaded into the funnel. Thus, in some embodiments, preferably the heart valve is loaded into and compacted within the funnel while the funnel is already disposed over the inner tube of the delivery device.

[0090] With reference next to Figure 14G, with the implant loaded into the compaction portion of the funnel, the support tube 290 preferably is advanced distally so that the eyelets 72 of the implant 140 are generally aligned with the bosses 294 of the support

tube. However, in the illustrated embodiment, the diameter of the compaction portion 250 of the funnel is greater than the diameter of the support tube 290, and thus the eyelets 72 are disposed radially outwardly from the bosses 294. With reference next to Figure 14H, preferably the inwardly biased O-ring 270 is slipped off of the end of the funnel and onto the exposed connecting portions of the stent frame so as to urge the eyelets inwardly and into engagement with the aligned bosses. The implant is thus connected to the support tube 220.

[0091] With reference next to Figure 14I, with the eyelets 72 and bosses 294 engaged, the outer sheath is then advanced distally over the support tube 290 so that the distal end of the outer sheath extends over and distally past the bosses. As discussed above, the lumen diameter of the outer sheath is chosen so that the inner surface 304 just clears the bosses 294 of the support tube. Thus, when the outer sheath is moved distally past the bosses when the bosses are engaged with the eyelets 72, the eyelets are captured between the outer sheath 300 and support tube 290, and the first end of the stent is securely held by the support tube. With the eyelets now fully captured, the O-ring is removed.

[0092] With reference next to Figure 14J, the outer sheath 300 continues to be moved distally relative to the support tube 290 and attached implant 140. In the illustrated embodiment, the outer sheath inner diameter is less than the diameter of the funnel compaction portion. Thus, as the outer sheath is moved distally, it progressively radially compacts the heart valve implant. As the implant is progressively compacted within the outer sheath, the funnel 240 preferably is also moved distally so that the implant is progressively transferred from being contained within the funnel to being contained within the outer sheath 300. Eventually, the funnel is completely removed from the implant and the outer sheath contains the implant from its first to its second end, as shown in Figure 14K.

[0093] In the embodiment illustrated in Figure 14K, the stent frame 140 of the implant has anchors 190 extending radially outward at the second end 144. Those anchors are not captured within the outer sheath in this embodiment, although the outer sheath preferably captures substantially the rest of the stent frame therewithin.

[0094] With the implant captured in the outer sheath, the funnel preferably can be removed from the delivery device. In the illustrated embodiment, the smallest diameter portion of the funnel is greater than the outer diameter of the nose cone. Thus, the funnel can

be removed by moving it distally over the nose cone. In other embodiments, the funnel may have a lesser diameter than the nose cone, and can be moved by other means such as by cutting the funnel. In still other embodiments, the funnel can have a multiple piece and/or hinged construction and may be held closed by a releasable clamp, clip, or the like. As such, once it has served its purpose and the implant is transferred to the outer sheath, the funnel can be disassembled and/or opened and removed without necessarily drawing the funnel over the nose cone.

[0095] With reference next to Figures 14K and 14L, with the funnel removed and the implant substantially captured within the outer sheath 300, the nose cone 276 is pulled proximally until as shown in Figure 14L, the skirt portion 284 of the nose cone engages and compacts the anchors 190, and eventually the proximal end of the nose cone skirt engages the seats 308 defined on the raised portion of the outer sheath. The anchors 190 are thus secured between the nose cone skirt inner surface 286 and the outer sheath outer surface 302. The implant is thus fully contained within the delivery device 238 which preferably maintains a substantially contiguous outer surface. The implant may be delivered to a native heart valve annulus in a manner having similarities to the embodiment discussed above in connection with the Figures 12 and 13.

[0096] In the embodiment discussed above in connection with Figures 14, the nose cone 276 is depicted as rigidly attached to the inner tube 274. In another embodiment, the nose cone may be selectively detachable from the inner tube so that the valve implant can be independently drawn into a funnel compaction apparatus, without the funnel being mounted over the delivery device. Thus, a loaded funnel as depicted in Figure 14E can be advanced over an inner tube, and then the nose cone may be attached to the inner tube. In such an embodiment, the funnel may have a smaller diameter than as shown and discussed above, as the funnel is not necessarily of large enough diameter to be drawn over the nose cone, and instead the nose cone may be removed in order to remove the funnel. In fact, in such an embodiment and in some options of such an embodiment, the nose cone is not attached to the inner tube until after the funnel is removed and the implant is substantially captured within the outer sheath.

[0097] With reference next to Figures 15A-H further embodiments of a device for loading a heart valve implant 128 onto a delivery device 238 are shown. For ease of illustration, the same implant 128/stent frame 140 used in connection with the embodiment described in Figure 14 is employed, as well as other similar structures, such as the pull member 260, and delivery device 238 structure such as the inner tube 274, nose cone 278, support tube 290 and outer sheath 300.

[0098] With particular reference to Figure 15A, the illustrated embodiment comprises a two-piece compaction device 310 comprising a funnel portion 315 and a loading tube portion 320. Preferably, the funnel portion 315 and the loading tube portion are detachably connected to one another. Further, preferably the loading tube portion 320 is elongate and has a substantially constant diameter. As with other embodiments, preferably the octopus arms 264 of the pull member 260 extend through the compaction device 310 to hook onto and engage portions of the implant 128, 140. In the illustrated embodiment, the hooks 266 engage the stent 140 at the second end 144 of the stent.

[0099] In practice, the pull ring 262 is pulled so as to pull the stent into the compaction device and through the funnel portion 315 to radially compact the stent 140. Preferably, however, a loading inner tube 328 is arranged concentrically within the stent 140 as it is being compacted. As shown in Figure 15B, the implant 128, 140 eventually is radially compacted within the loading tube 320 and concentrically surrounding the loading inner tube 328. As shown in Figure 15B, preferably the loading tube 320 has a length that is somewhat less than the total length of the stent 140 when the stent is in its compacted arrangement. As such, at least the eyelets 72 of the first end 142 extend beyond an end of the loading tube 320.

[0100] With reference next to Figure 15C, once the implant 128 is compacted within the loading tube 320, the pull member 260 may be detached from the implant and the loading tube may be detached from the funnel portion 315 so that the loading tube end associated compacted stent 140 and inner loading tube 328 can be independently moved and manipulated.

[0101] Figure 15C shows an embodiment in which the delivery device 238 is configured so that the nose cone 276 can be releasably detached from the inner tube 274. Preferably, the inner loading tube 328 defines an inner lumen having a diameter greater than

the outer diameter of the inner tube 274 so that the inner loading tube can be threaded over the inner tube so as to place the compacted implant 128, 140 on the delivery device 238 between the nose cone 276 and the support tube 290. In another embodiment, the nose cone is not detachable from the inner tube. Thus, in order to get the compacted implant disposed on the delivery device 238, the implant is threaded onto the inner tube 274 before the support tube 290 and outer sheath 300 are threaded over the inner tube 274.

[0102] In either case, however, once the support tube 320 with its accompanying compacted implant are threaded over the inner tube 274 as desired, the inner loading tube preferably is removed from within the compacted implant and removed from the delivery device. For example, in the embodiment illustrated in Figure 15C, the loading inner tube 328 can be removed distally off the end of the inner tube 274 when the nose cone 276 is detached. In other embodiments, the loading inner tube 328 can be slid off of the inner tube 274 before the support tube 290 and outer sheath 300 are advanced over the inner tube 274. As such, and as shown in Figure 15B, the loading tube 320 with its attendant compacted implant 128, 140 is disposed on the inner tube 274 between the nose cone 276 and the support tube 290.

[0103] With reference next to Figures 15E-15H, preferably the delivery device 238 is then manipulated and operated in a manner similar to that as discussed above in connection with Figures 14G-K so as to capture the first end 142, and more specifically the eyelets 72, of the stent frame 140 within the outer sheath 300 using a method of apparatus including the support tube 290 and bosses 294, although other configurations of locking mechanisms 292 may be employed as desired.

[0104] With specific reference next to Figure 15G, in one embodiment, after the implant has been captured within the outer sheath 300, the loading tube portion 320 preferably is removed from around the delivery device 238. In the embodiment illustrated in Figure 15G, the loading tube 320 can be moved proximally over the outer sheath 300 as the outer sheath engages the nose cone 276. In the embodiment illustrated in Figure 15H, the loading tube 320 is advanced distally so as to be removed over the nose cone 276 as the outer sheath also is distally to engage the nose cone 276.

[0105] In the illustrated embodiments, the loading tube 320 has a lumen diameter sufficiently large so that it can be removed over the nose cone 276, or at least clear the raised

portions 306 of the outer sheath 300. In other embodiments, however, the loading tube may have a lumen diameter more closely approaching the inner diameter of the outer sheath lumen. Removal of the loading tube 320 after the implant is sheathed within the outer sheath 300 may involve breaking or cutting the loading tube 320 or, in other embodiments, the loading tube comprises multiple pieces that can be disassembled or opened so as to remove the tube from the delivery device 238.

[0106] In one of the embodiments discussed above, the nose cone is detachable from the inner tube. It should be understood that, in one such embodiment, the nose cone is not reattached to the inner tube until after the compacted stent is at least partially pulled into the outer sheath, and the loading tube is removed from the delivery device 238. As such, in this embodiment, the loading tube can have a lumen diameter less than an outer diameter of other structures of the delivery device.

[0107] In the embodiments discussed above, an inwardly-biased O-ring 270 is employed to urge locking members 72 of the stent into engagement with locking bosses 294 of the support tube 290. It is to be understood, however, that other methods and structures can be employed to engage the locking members of the stent with the support tube. For example, a user can manually urge the locking members into engagement with the bosses. Additionally, other structures, such as a belt, specially-configured clamping pliers, or the like can be employed to urge the locking members into engagement with one another. It is contemplated that yet further structures can be employed for this purpose.

[0108] With reference next to Figure 16A and 16B, another embodiment of a multi-piece compaction device 410 comprises a funnel portion 415 and an elongate load tube 420 that are detachably connected to one another. The funnel portion and load tube preferably share at least some features with other embodiments discussed in this specification. In the illustrated embodiment, the smaller end of the funnel portion comprises an L-lock track 417 formed therein. The load tube 420 comprises an overlap portion 422 having a lock member 424. A diameter of the overlap portion 422 is reduced so that the overlap portion will fit within the end of the funnel portion 415 at the L-lock track 417. The lock member 424 is slidable within the track 417 so as to detachably secure the

funnel portion 415 and load tube 420 together. It is to be understood that other structures can be employed to detachably connect the funnel and load tube.

[0109] With reference next to Figures 17A-G, in another embodiment, an implant 400 is provided in which longitudinal struts 406 terminate in locking member 404 at a non-anchoring end of the stent 400. The illustrated locking members 404 have a generally arrowhead-type shape that is enlarged relative to the adjacent strut 406. Preferably a pull member 260a engages the stent 400 and pulls it through the compaction device 410 so that the implant 400 is compacted within the load tube 420. The load tube and implant can then be removed from the pull member 260a and funnel portion 415 and loaded onto an inner tube 274a of a delivery device.

[0110] With particular reference to Figure 17B, the delivery device preferably includes the inner tube 274a, which is attached to a nose cone 276a. A support tube 430 is slidably disposed over the inner tube, and an outer sheath 300a is slidably disposed over the inner tube. Preferably an inner lumen diameter of the outer sheath 300a is greater than, but very close to, an outer diameter of the support tube 430. A locking mechanism 432 is provided at the distal end of the support tube 430. The locking mechanism 432 preferably comprises a tapered surface 434 that leads to a circumferential capture slot 440. A plurality of guide slots 444 are provided and configured to generally align with struts 406 of the implant 400. Preferably, the load tube 420 is sized such that the radially compacted implant 400 has an outer diameter less than an outer diameter of a proximal ridge of the tapered surface 434 immediately adjacent the capture slot 440.

[0111] To load the compacted implant 400, the support tube 430 is advanced so that the tapered surface 434 engages and deflects the locking members 404 and associated struts 406 of the implant 400, as shown in Figure 17C. The support tube 430 continues to be advanced until the deflected locking members 404 clear the proximal edge of the tapered surface 434, at which point the locking members 404 are no longer deflected, and will spring into the capture slot 440, preferably with an audible "click". When properly aligned, the struts 406 correspondingly spring into the guide slots 444 as depicted in Figure 17D, and the stent 400 and support tube 430 are now engaged.

[0112] With reference next to Figure 17E, the outer sheath 300a is next advanced distally so as to cover the capture slot 440 and thus securely capture the locking members 404 within the sheath 300a. As the sheath 300a continues to be advanced distally, the compacted implant is transferred from the load tube 420 to the sheath 300a. Preferably a distal end of the sheath engages an end of the load tube 420 during such advancement, and thus anchor members that may in some embodiments be biased radially outwardly can be effectively transferred from within the load tube 420 to within the sheath 300a.

[0113] With additional reference to Figure 17F, preferably the nose cone 276a is sized so that the load tube 420 can be slid thereover and removed from the delivery device. In the illustrated embodiment the distal end of the sheath 300a at least partially overlaps the nose cone, and the sheath is shaped to provide a smooth transition from the distal end of the sheath to the nose cone. Of course, other embodiments may employ other structural interaction between the outer sheath and the nose cone, which may in some embodiments be removable.

[0114] In practice, the illustrated delivery device has operational features that may be similar to other embodiments discussed herein. For example, the implant can be partially deployed, but resheathed for repositioning. If necessary, the implant can also be resheathed for removal from the patient. In some such embodiments, in the event of complete resheathing, radially-outwardly-biased anchor members may not be able to be completely recaptured within the outer sheath 300a in the same position as originally provided. However, continued advancement of the sheath 300a after engagement of the anchor can have the effect of bending the anchor backwardly (distally) so that it is effectively captured between the sheath and nose cone. The delivery device can then be further manipulated, and even removed from the patient, with the entire implant, including anchor portions, fully resheathed.

[0115] Although this invention has been disclosed in the context of certain preferred embodiments and examples, it will be understood by those skilled in the art that the present invention extends beyond the specifically disclosed embodiments to other alternative embodiments and/or uses of the invention and obvious modifications and equivalents thereof. In addition, while a number of variations of the invention have been shown and described in

detail, other modifications, which are within the scope of this invention, will be readily apparent to those of skill in the art based upon this disclosure. In fact, the embodiments specifically disclosed herein have been used as a vehicle to describe certain inventive features that can be employed alone or in various combinations in multiple additional embodiments. Thus, it is contemplated that various combinations or subcombinations of the specific features and aspects of the embodiments may be made and still fall within the scope of the invention. For example, support tube embodiments such as in Figure 14 can be modified to capture locking members within a capture slot as disclosed in Figure 17, and vice versa. Further, even though the stents described herein have been configured to foreshorten, certain features such as the methods and apparatus for controlled delivery as discussed in connection with Figure 12 and 13, can be employed with self-expanding stents that don't necessarily foreshorten, and don't necessarily have anchoring features comparable to the embodiments disclosed herein. Further, the delivery device depicted in Figures 12 and 13 can be replaced with delivery devices employing principles as discussed in Figures 14, 15, 17 or the like. Accordingly, it should be understood that various features and aspects of the disclosed embodiments can be combined with or substituted for one another in order to form varying modes of the disclosed invention. Thus, it is intended that the scope of the present invention herein disclosed should not be limited by the particular disclosed embodiments described above, but should be determined only by a fair reading of the claims that follow.

WHAT IS CLAIMED IS:

1. A method of loading a device for delivering a self-expanding vascular implant, comprising:
 - drawing a relaxed, expanded vascular implant through an elongate form having a decreasing diameter to a load tube portion having a compacted diameter;
 - engaging a locking end of the implant with a locking mechanism disposed on a support tube;
 - advancing an outer sheath over the engaged locking end and support tube so as to capture the locking end between the sheath and support tube; and
 - advancing the outer sheath over the compacted implant so as to transfer the implant from within the load tube to within the outer sheath.
2. A method as in Claim 1, wherein transferring the implant from within the load tube to within the outer sheath comprises further compacting the implant.
3. A vascular implant delivery device, comprising:
 - an elongate support tube having a distal end, a locking mechanism being disposed at or adjacent the distal end;
 - an elongate sheath adapted to slide over the support tube; and
 - a self-expanding vascular implant having a locking member;wherein the support tube locking mechanism is configured to engage the implant locking member so as to block axial movement of the implant when the locking mechanism and locking member are engaged; and
 - wherein the sheath has an inner lumen sized to block the implant locking member from moving radially relative to the support tube locking mechanism sufficient to release from the support tube locking mechanism.
4. A vascular implant delivery device as in Claim 3, wherein the self-expanding vascular implant remains connected to the support tube so long as the sheath extends distally past the support tube locking mechanism, and wherein the device is configured so that when the sheath is moved proximally past the support tube locking mechanism, the implant locking member moves radially out of engagement with the support tube.

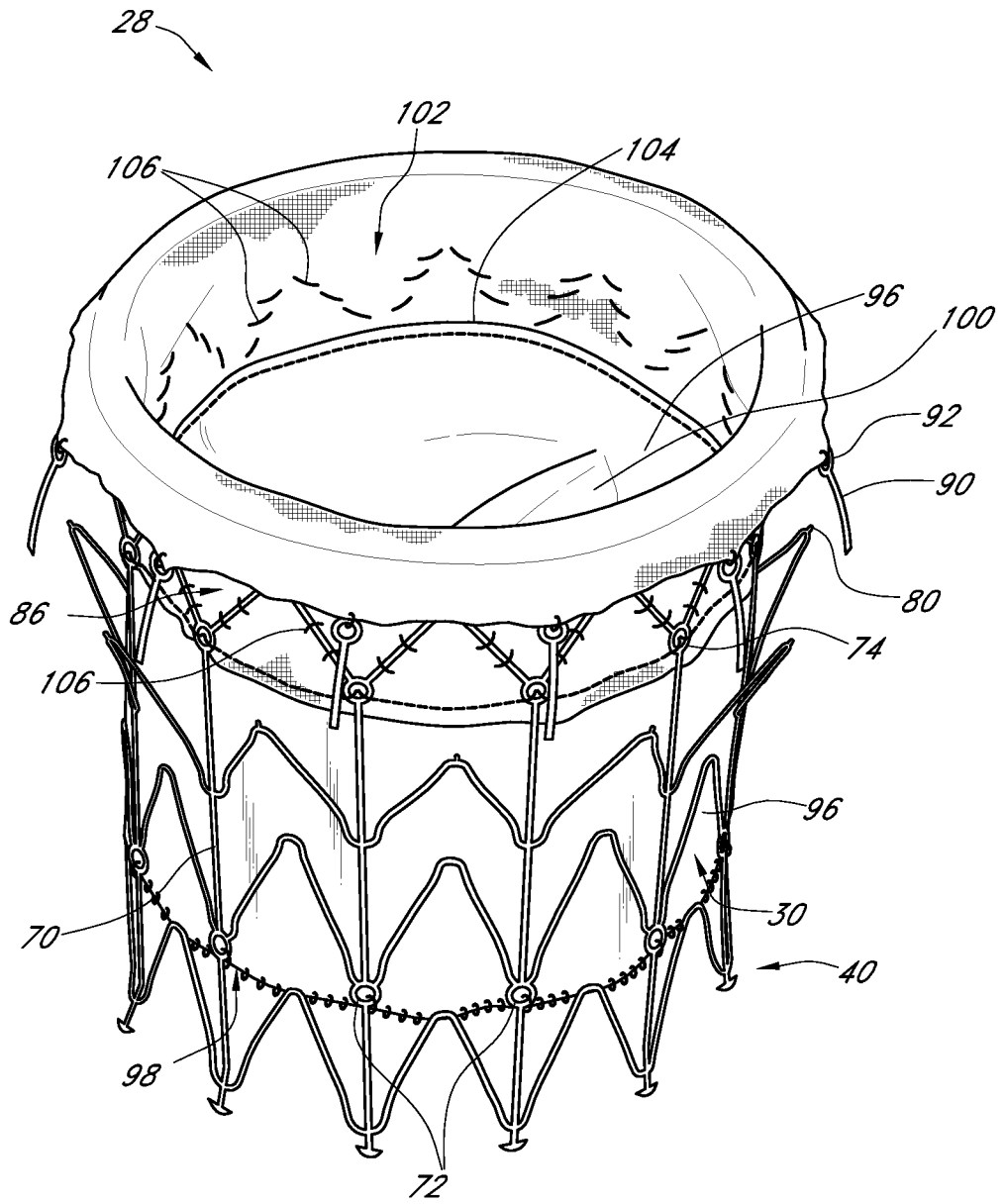

FIG. 1

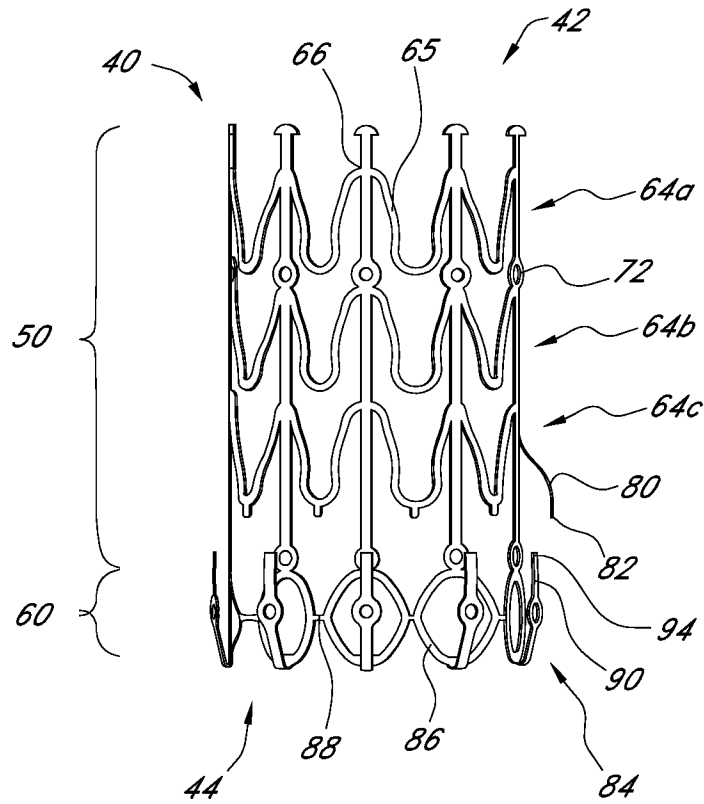

FIG. 2A

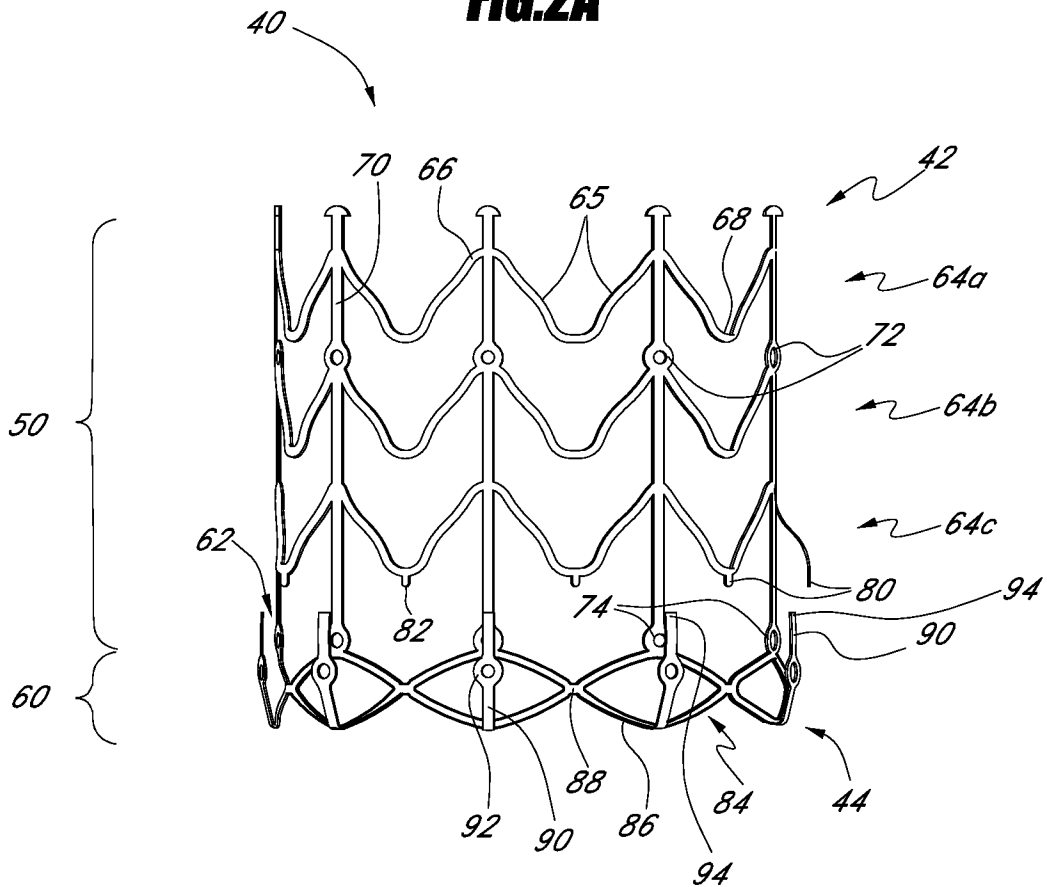

FIG. 2B

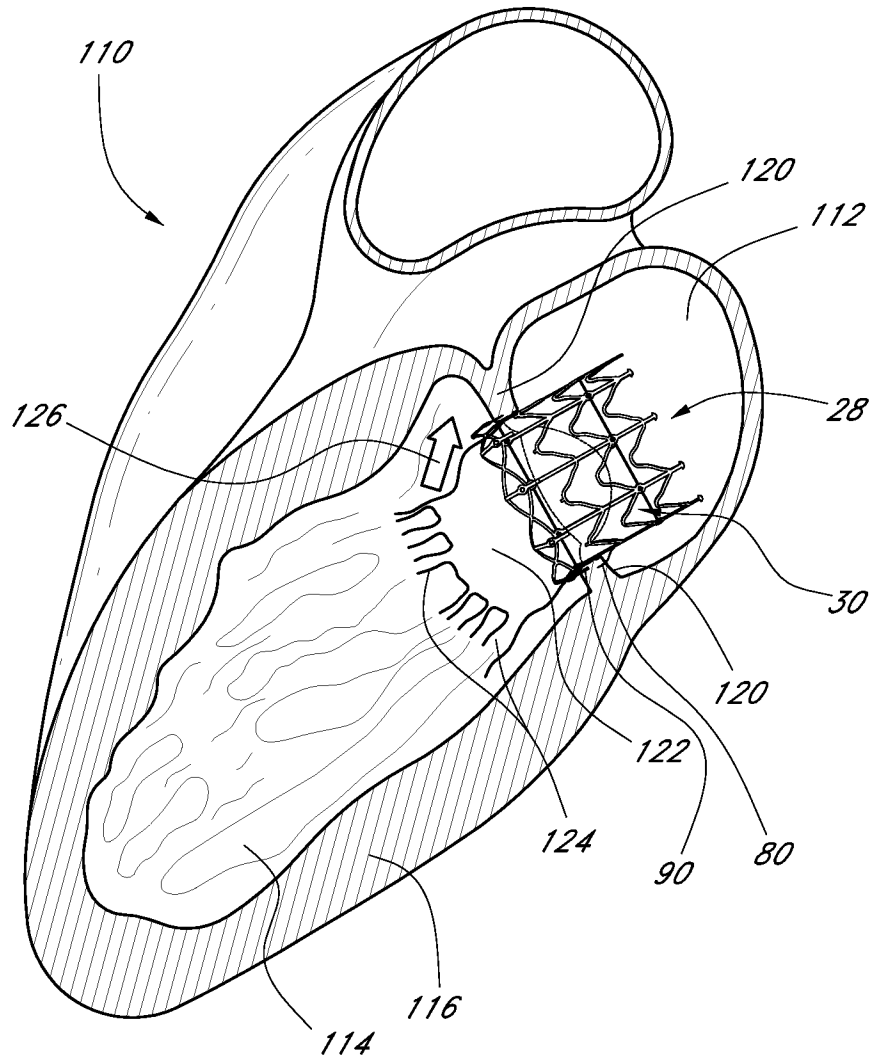

FIG.3

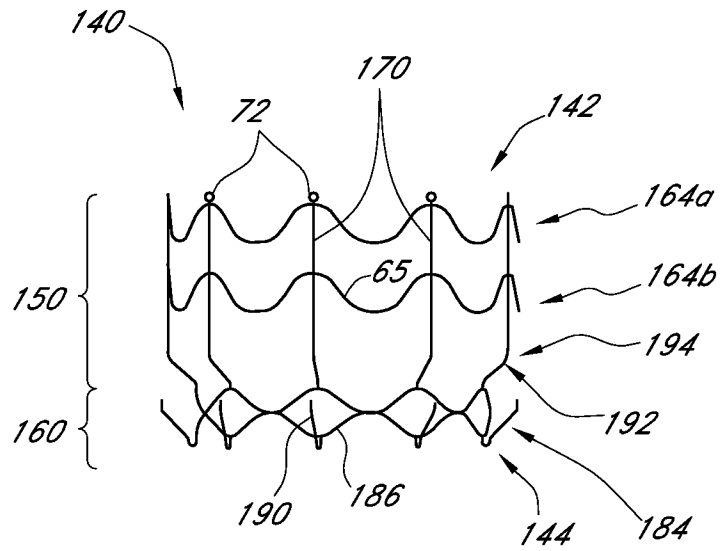

FIG. 4

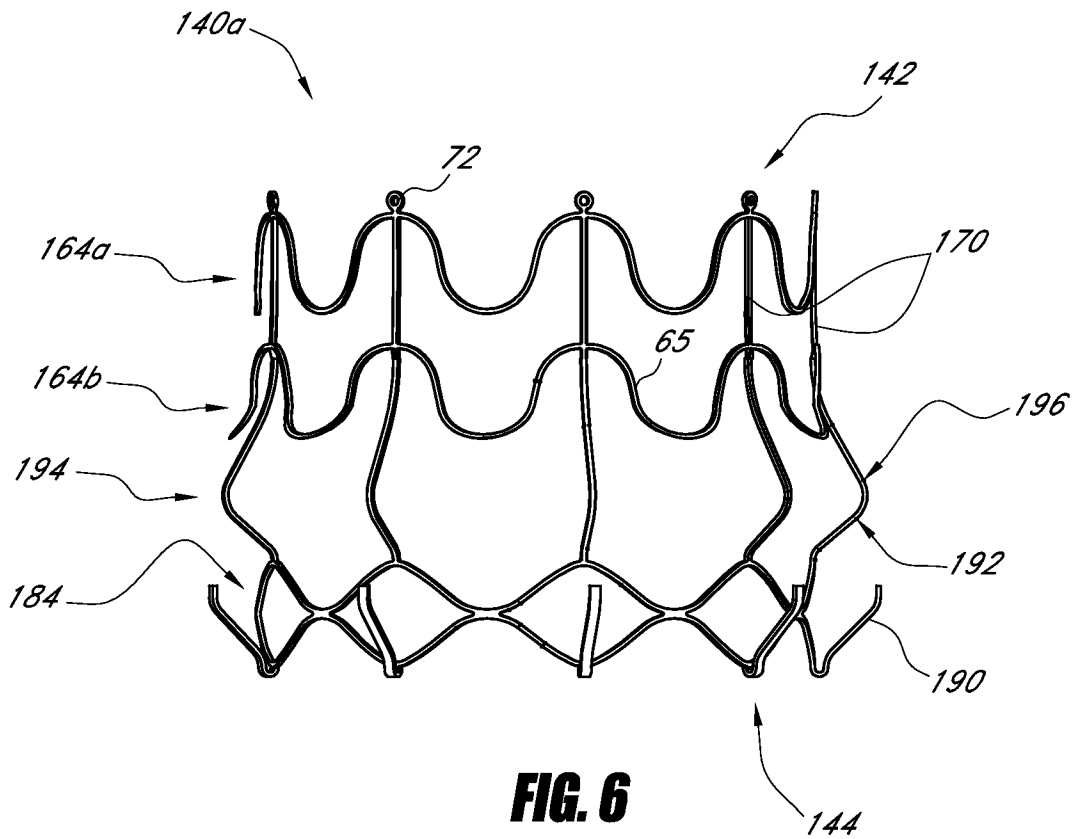

FIG. 6

5/26

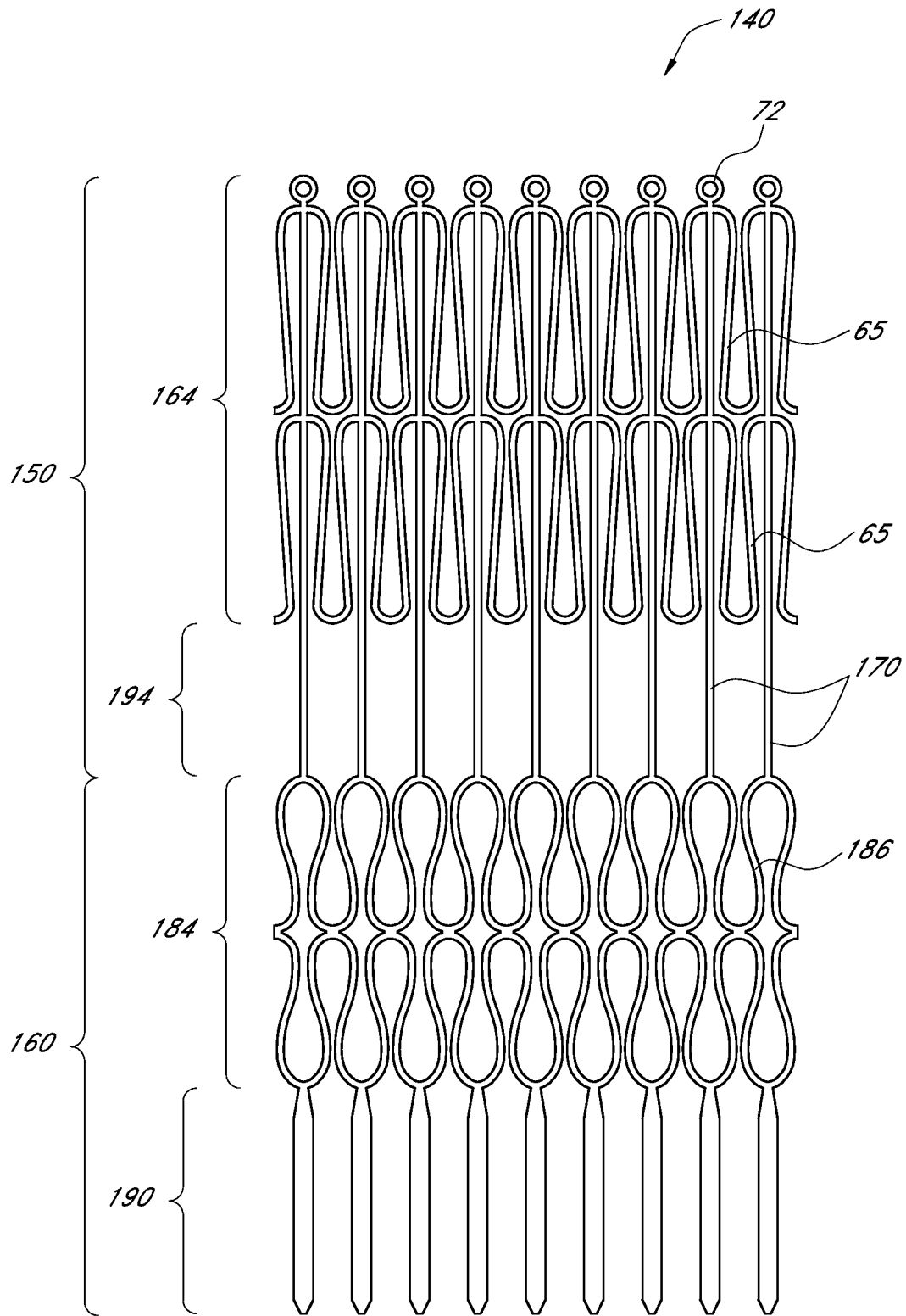

FIG. 5

6/26

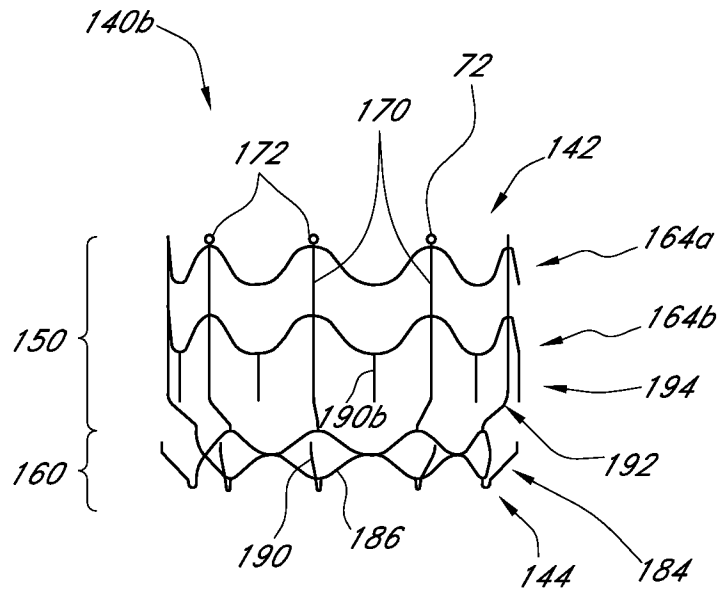

FIG. 7

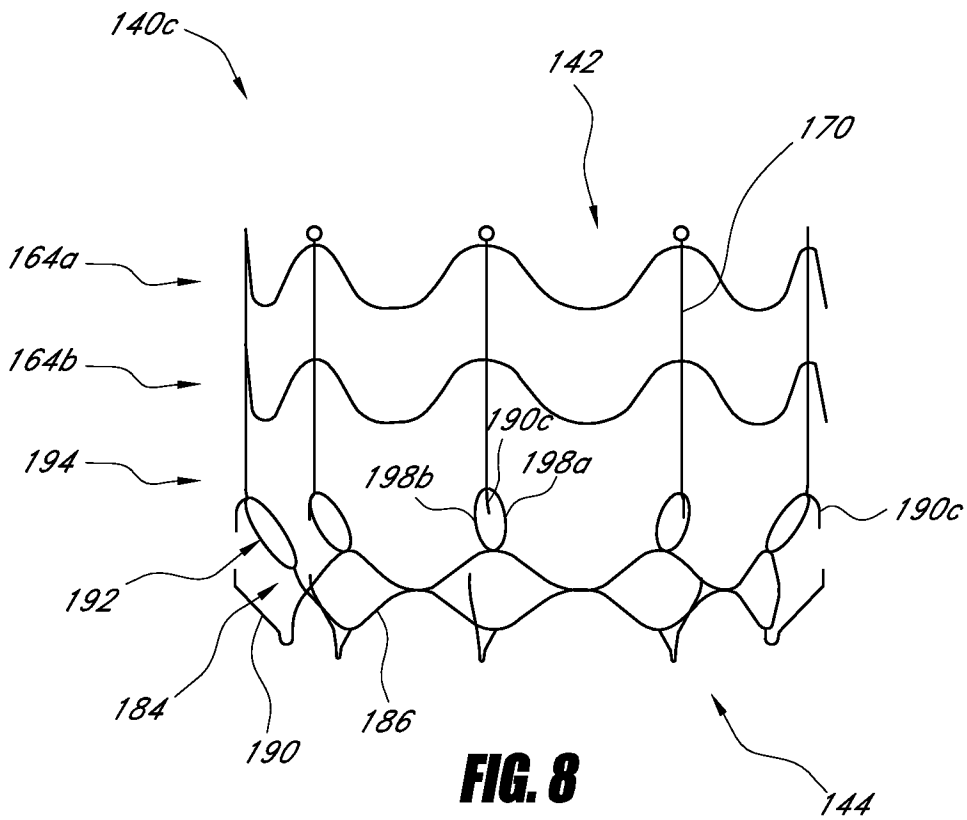

FIG. 8

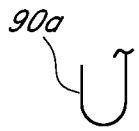

FIG. 9A

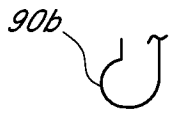

FIG. 9B

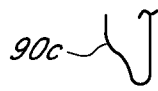

FIG. 9C



FIG. 9D



FIG. 9E

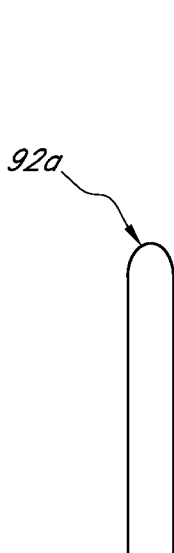

FIG. 10A

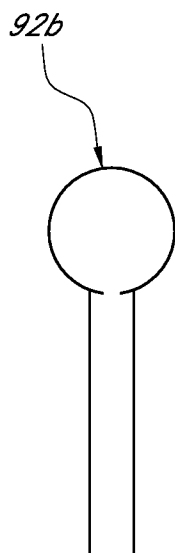

FIG. 10B



FIG. 10C

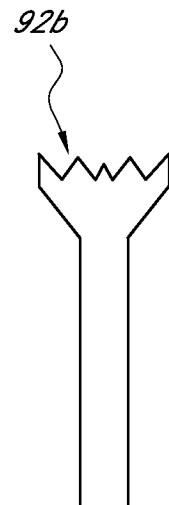

FIG. 10D

8/26

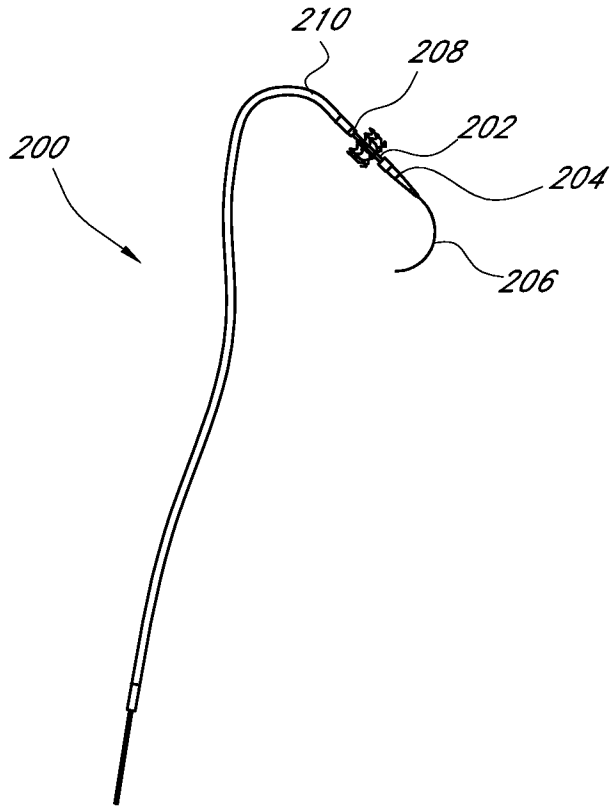

FIG. 11A

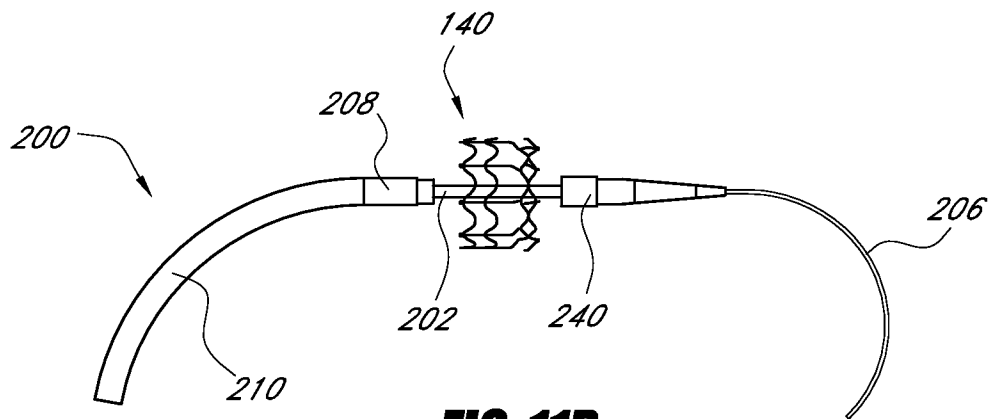

FIG. 11B

9/26

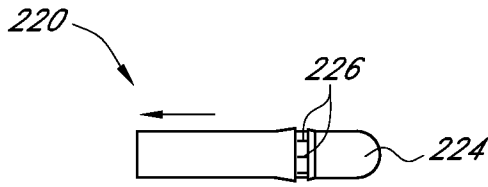

FIG. 12A

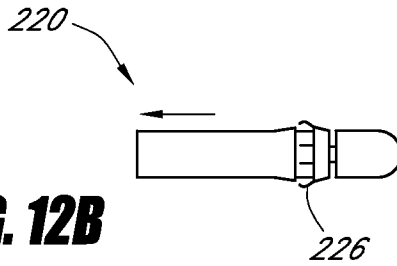

FIG. 12B

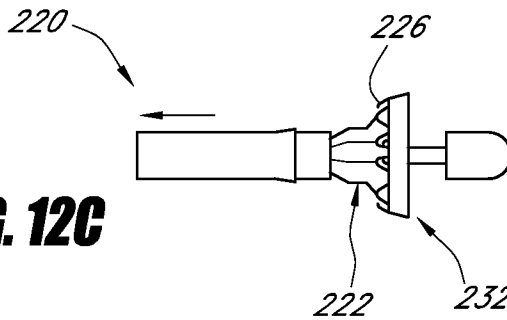

FIG. 12C

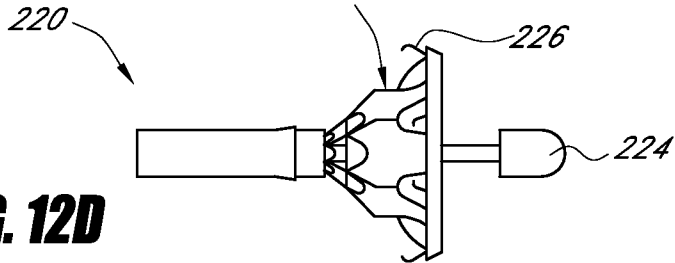

FIG. 12D

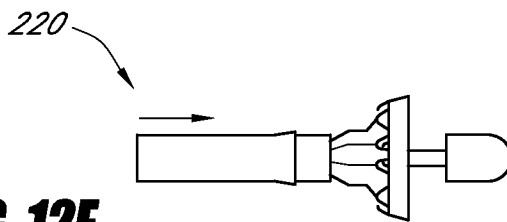

FIG. 12E

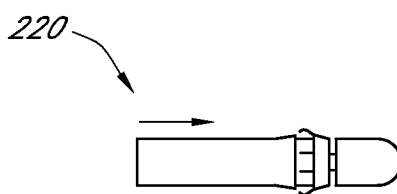
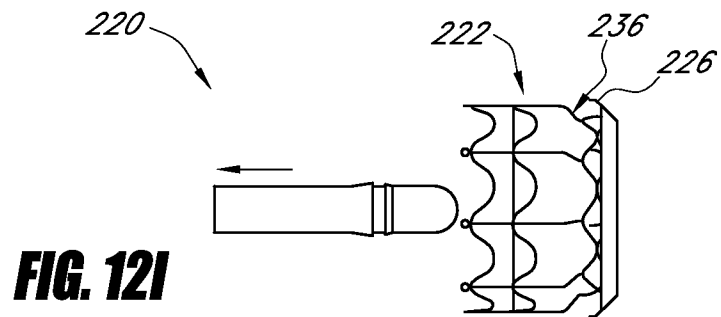
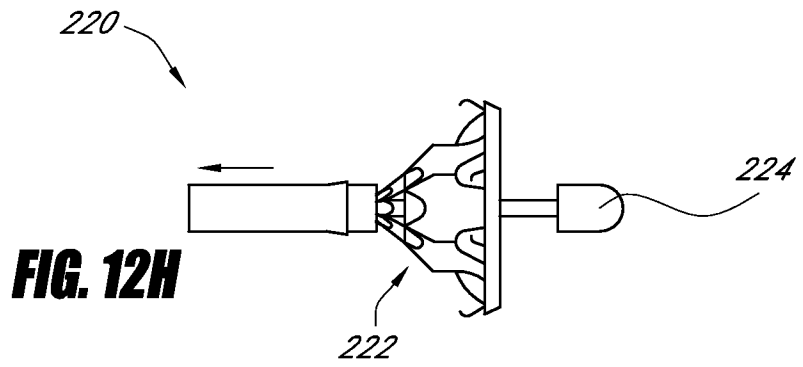
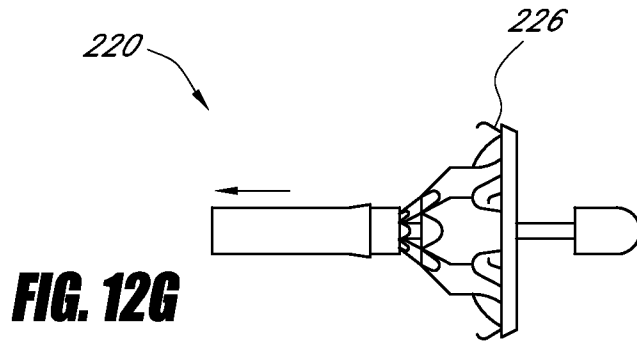
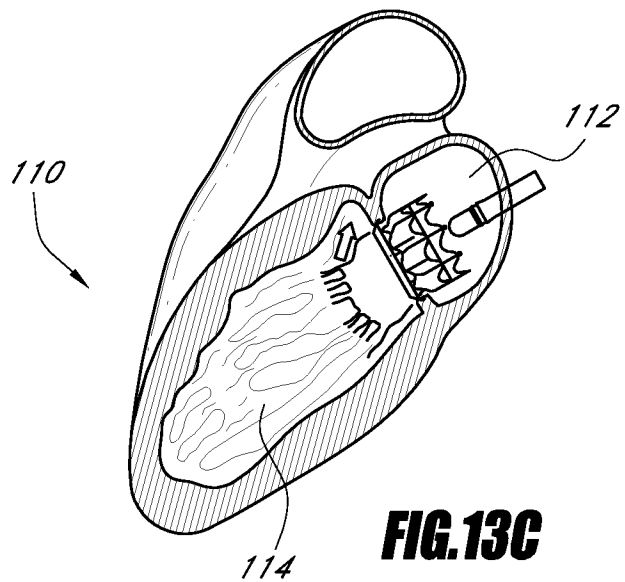
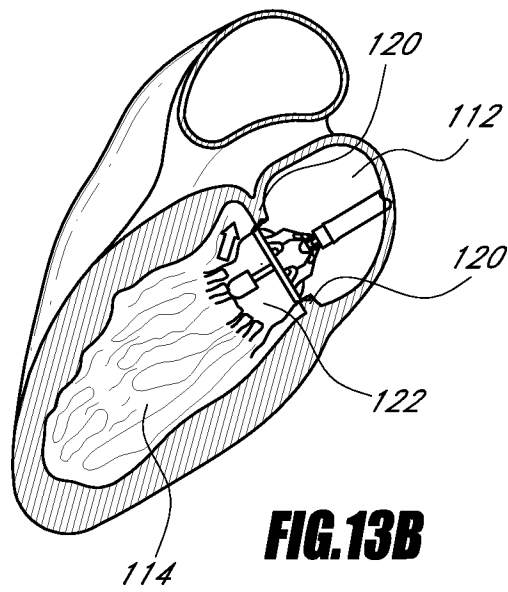
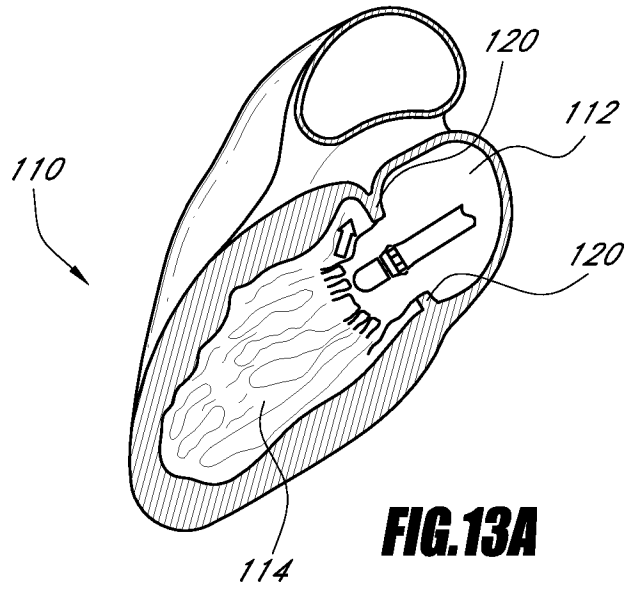
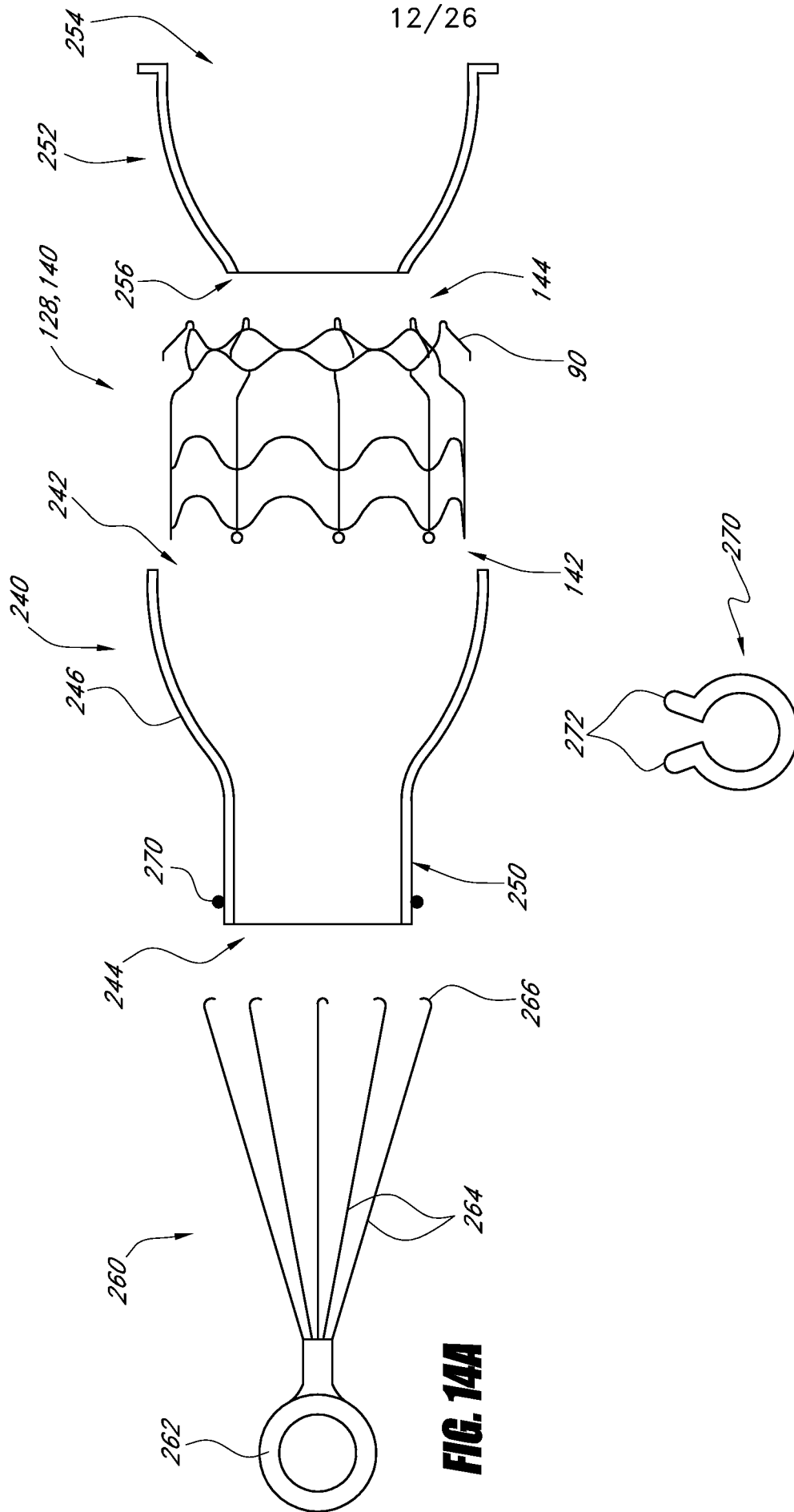

FIG. 12F



11/26





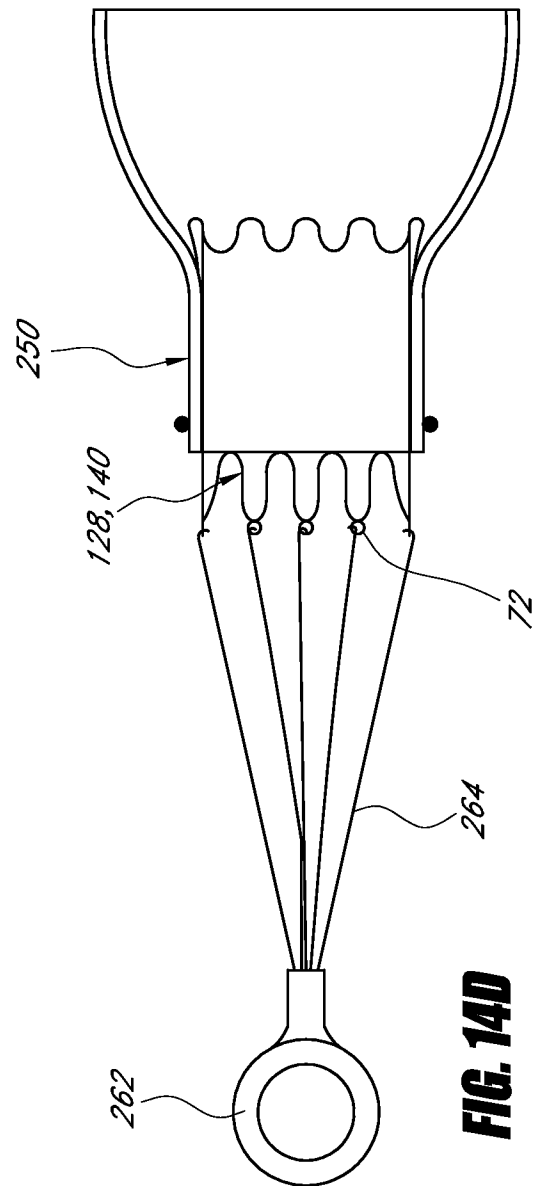
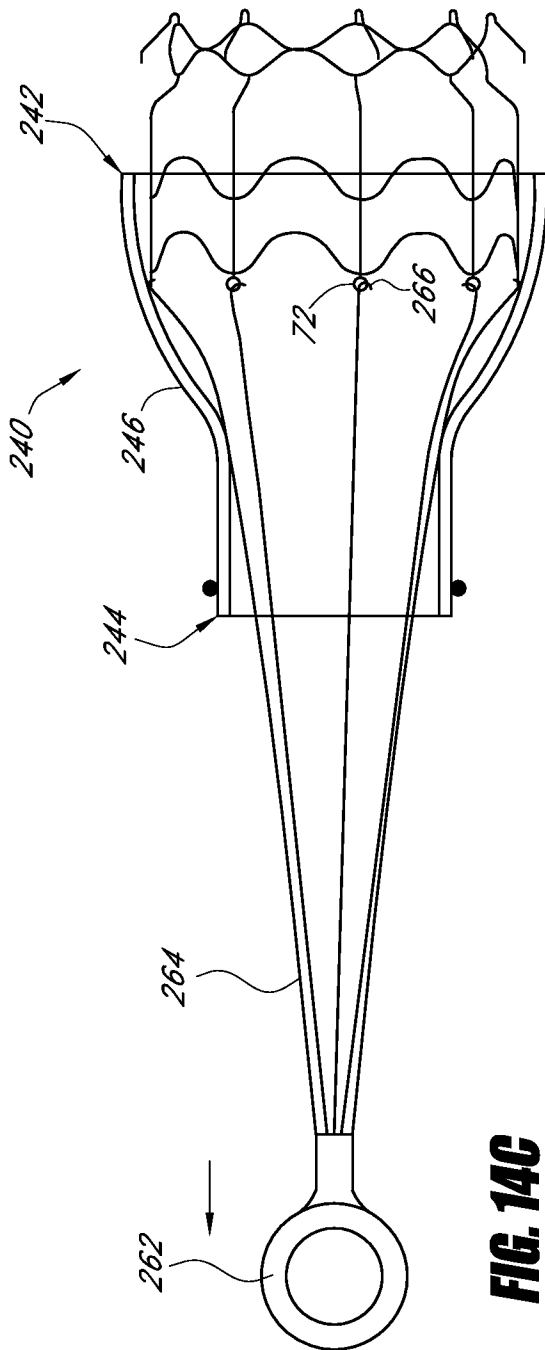

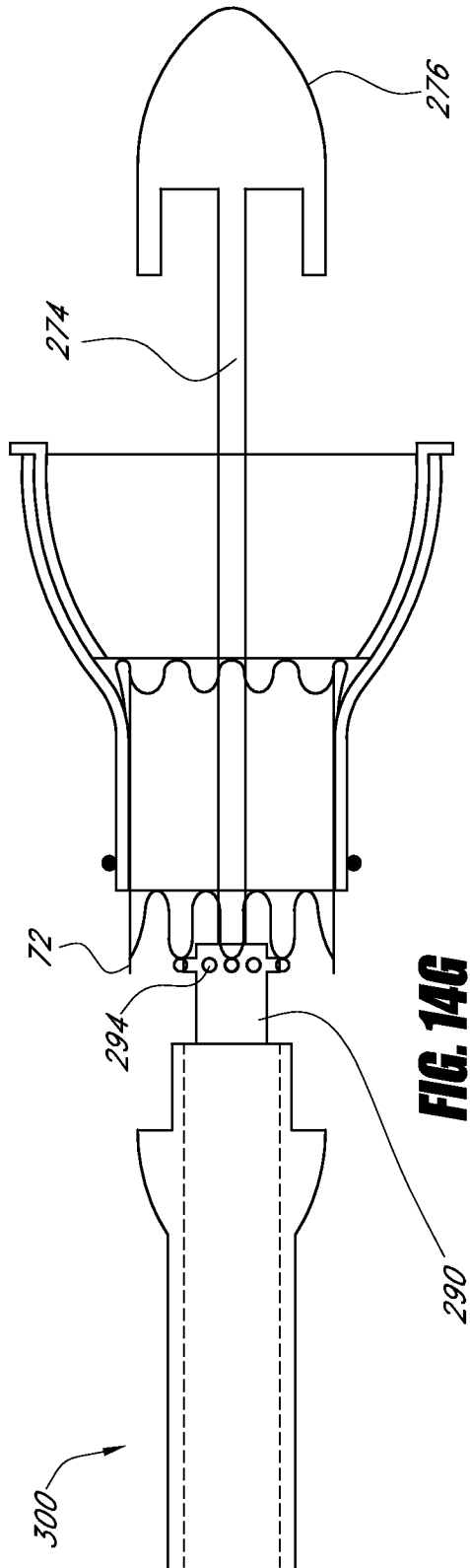

FIG. 14G

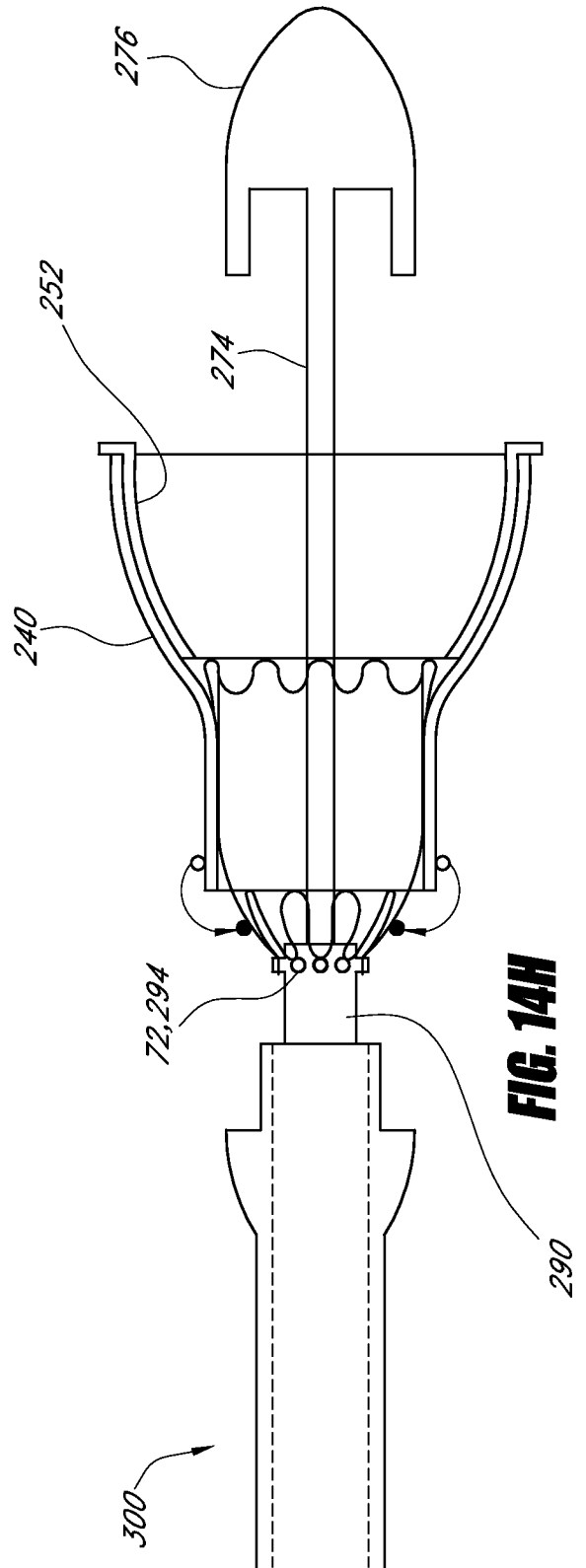

FIG. 14H

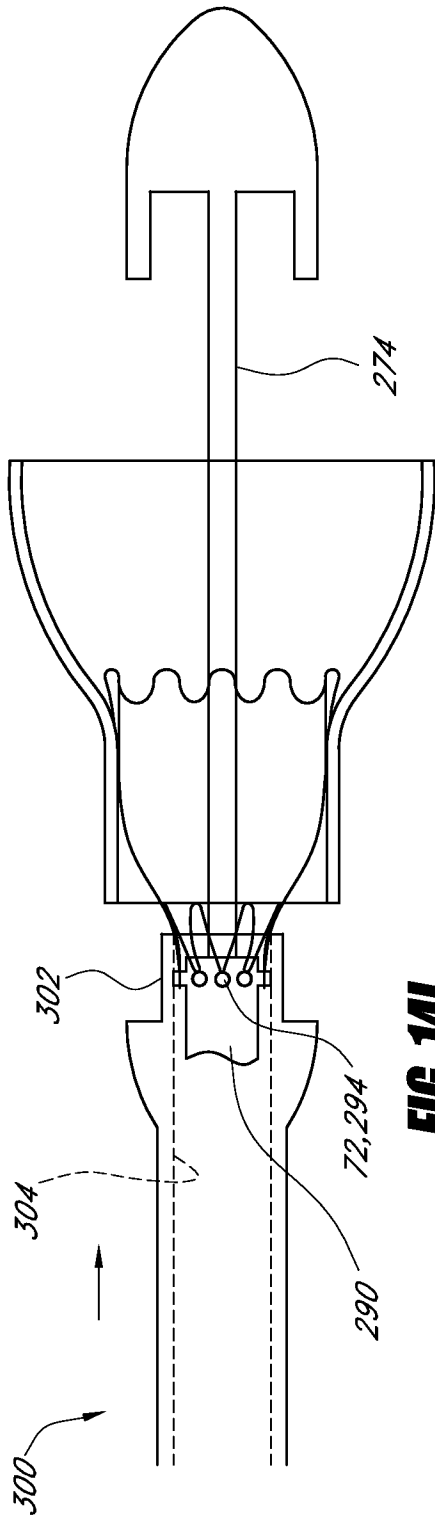

FIG. 14I

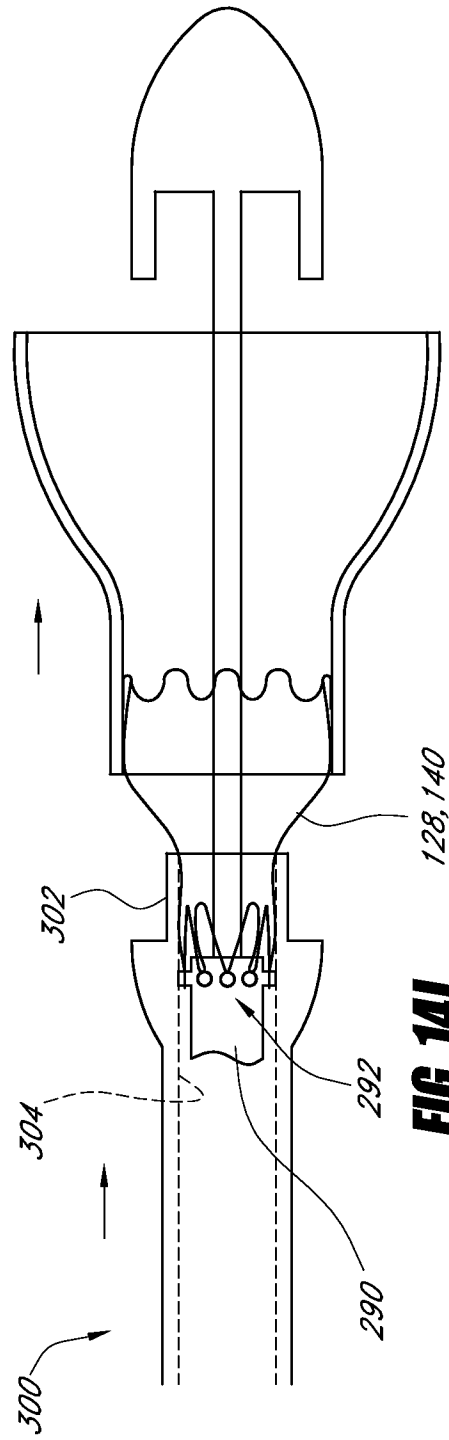
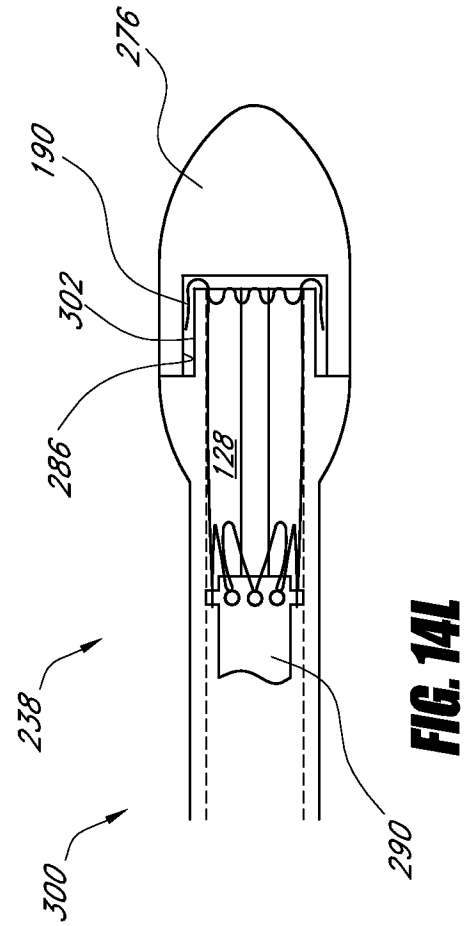
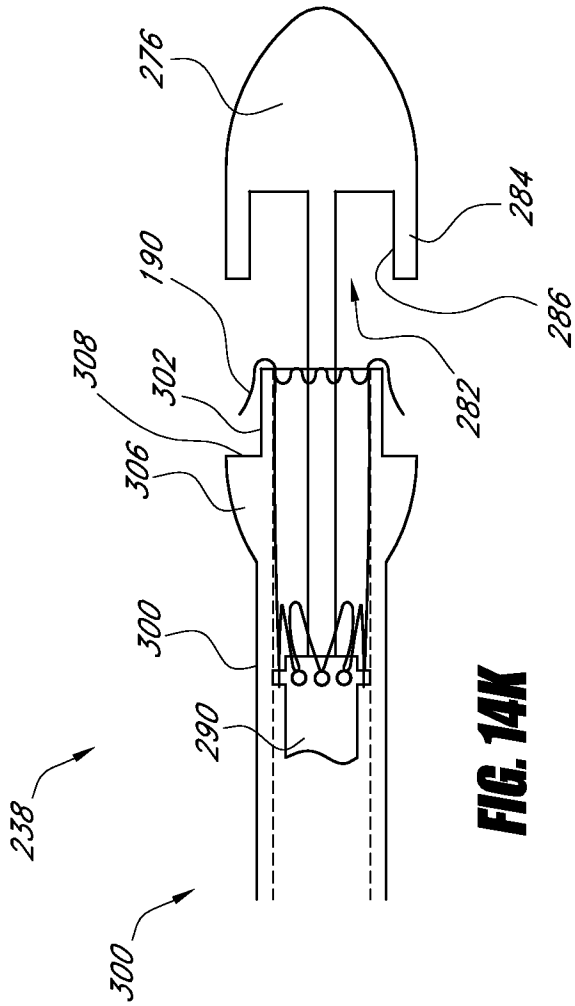

FIG. 14J



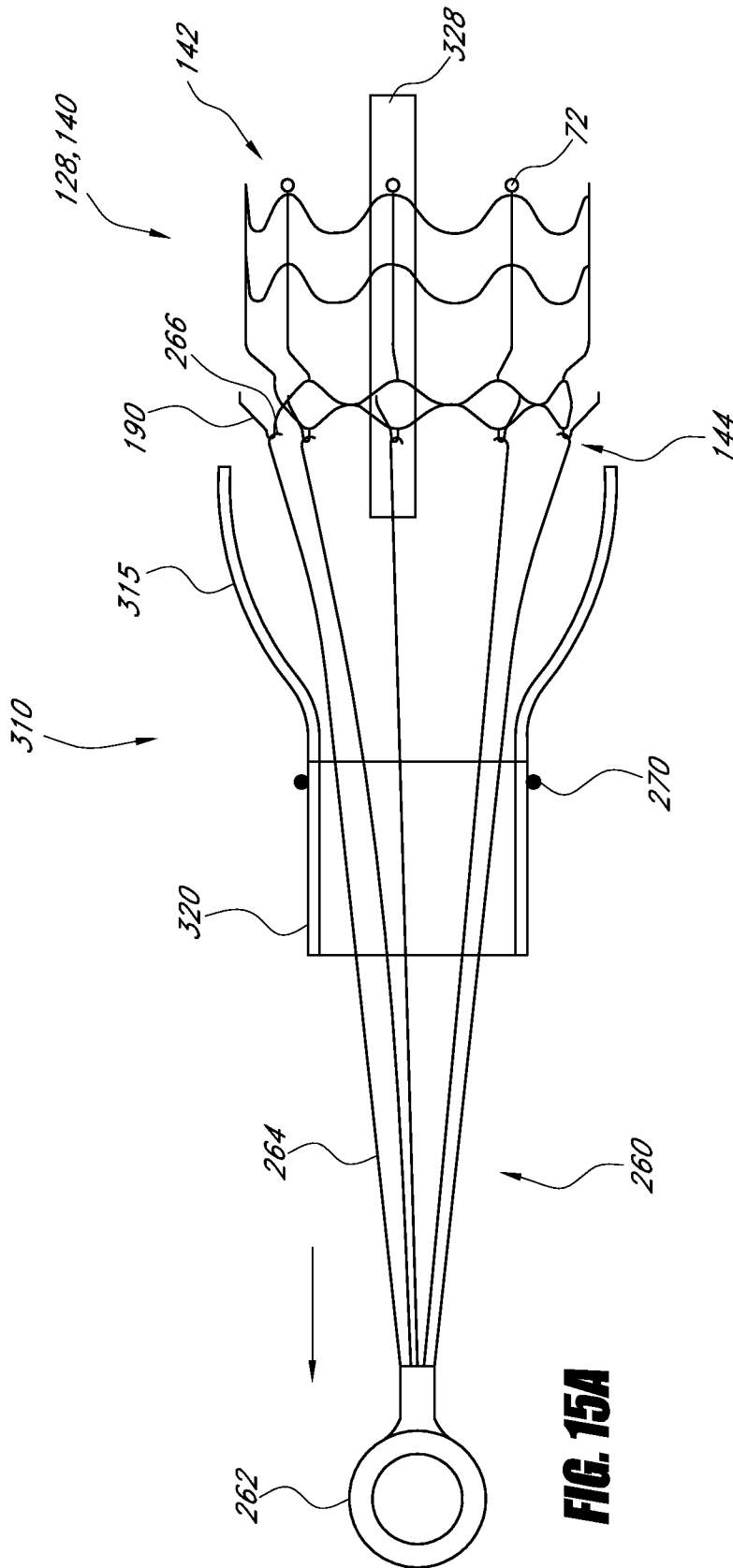

FIG. 15A

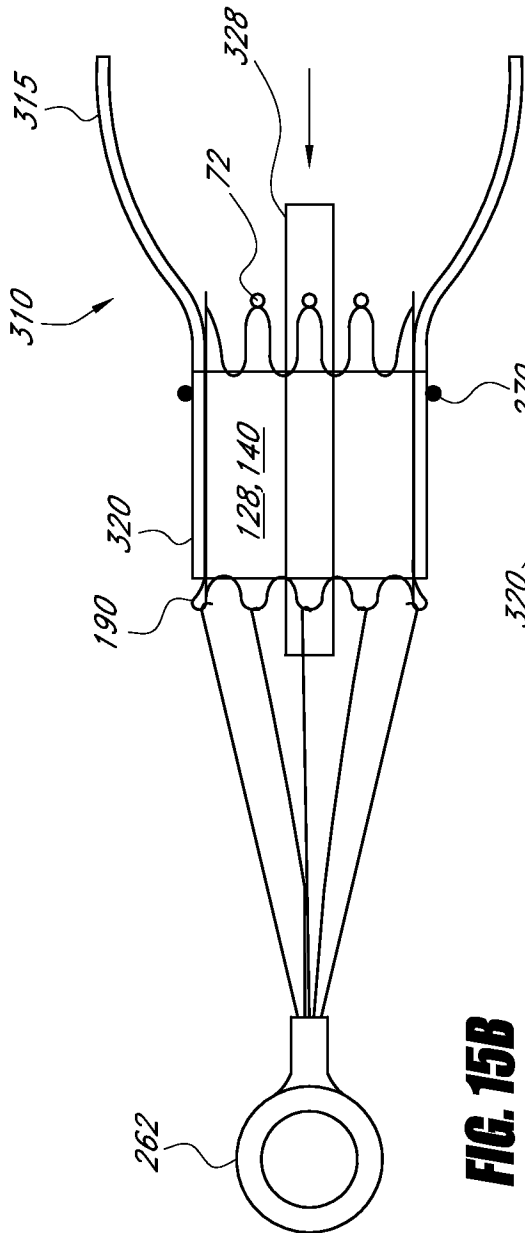

FIG. 15B

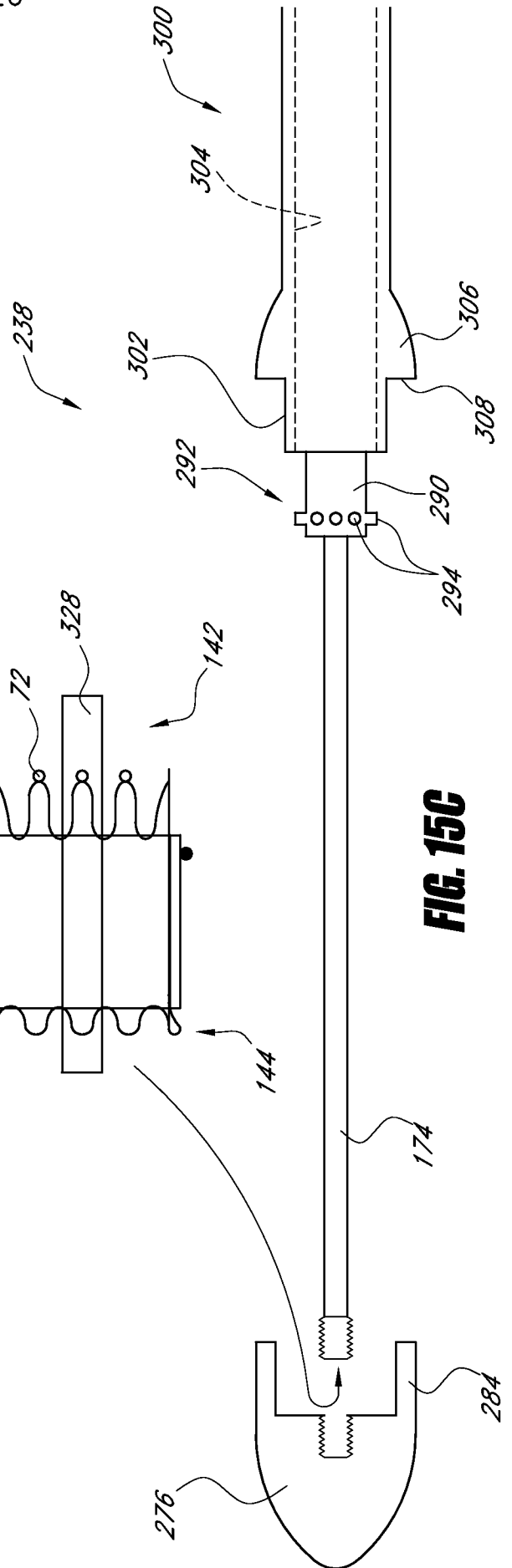

FIG. 15C

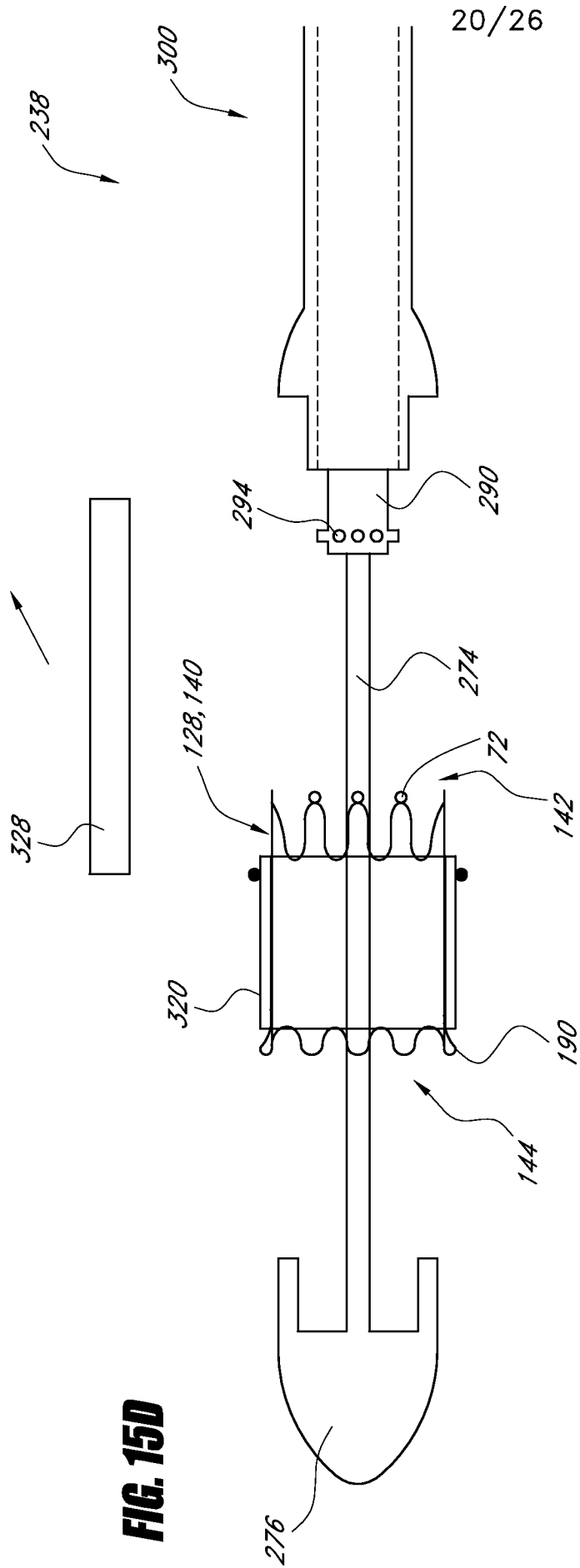

FIG. 15D

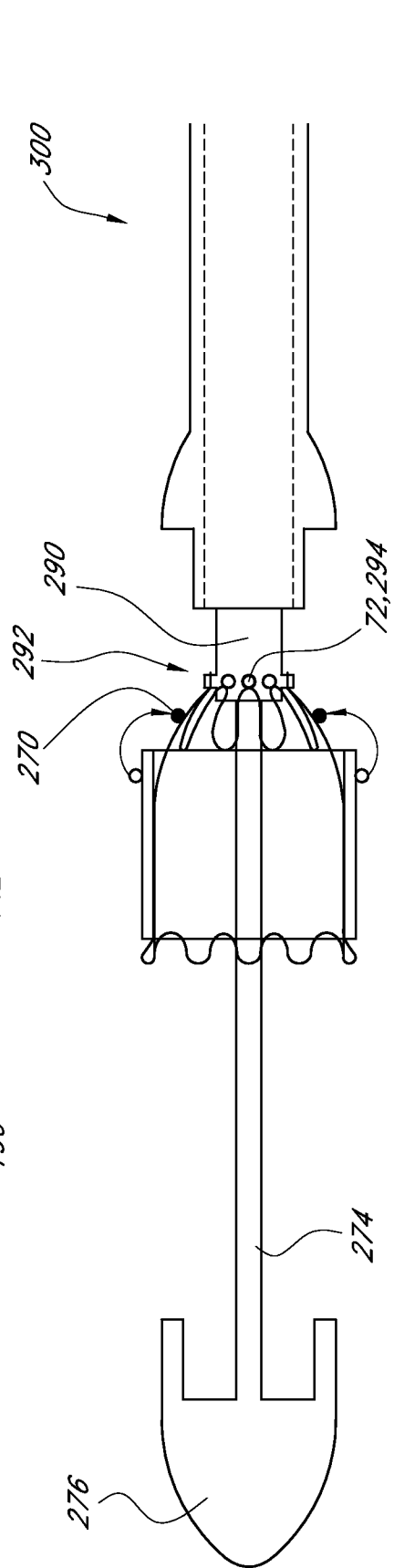

FIG. 15E

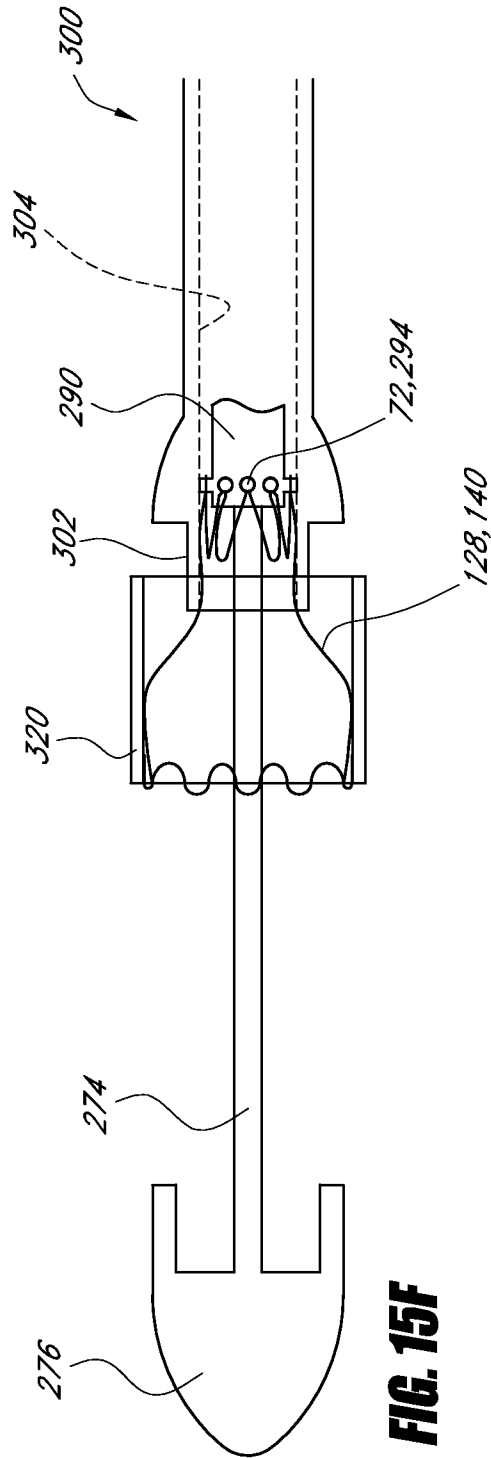

FIG. 15F

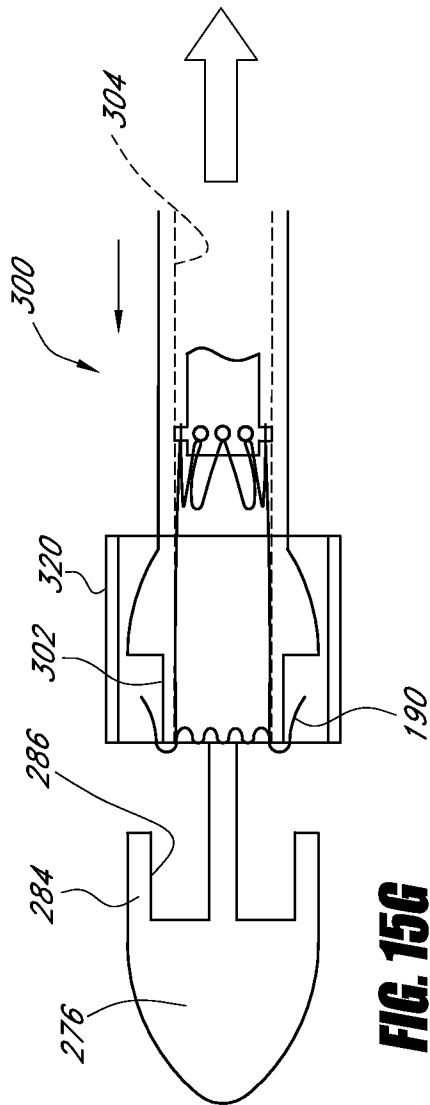
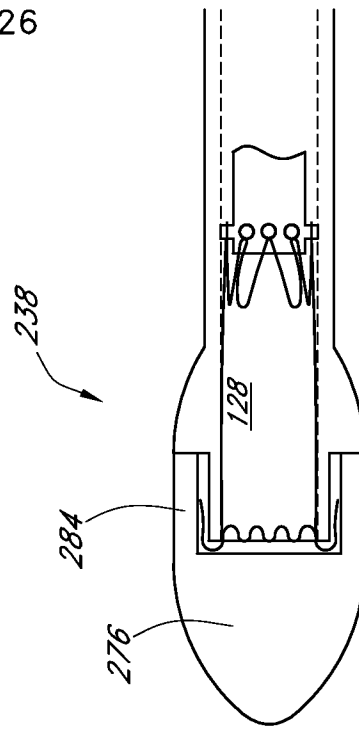
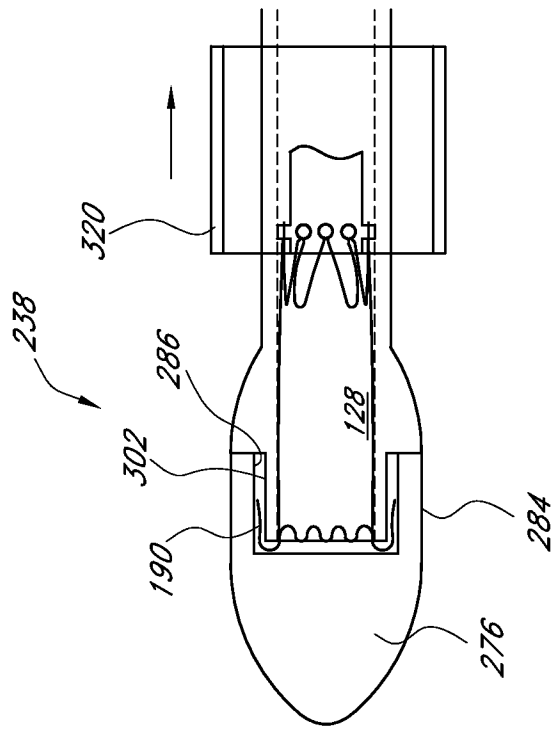

FIG. 15G

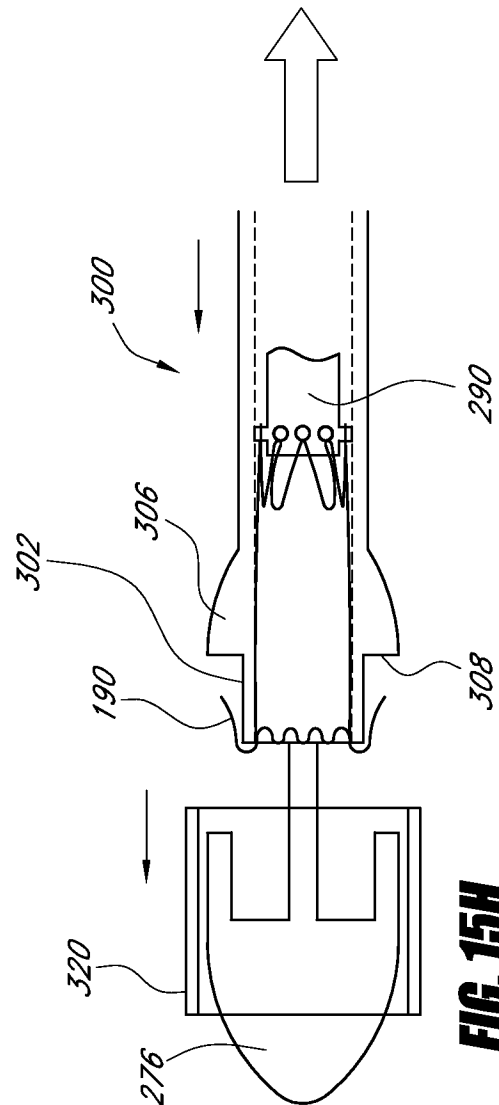

FIG. 15H

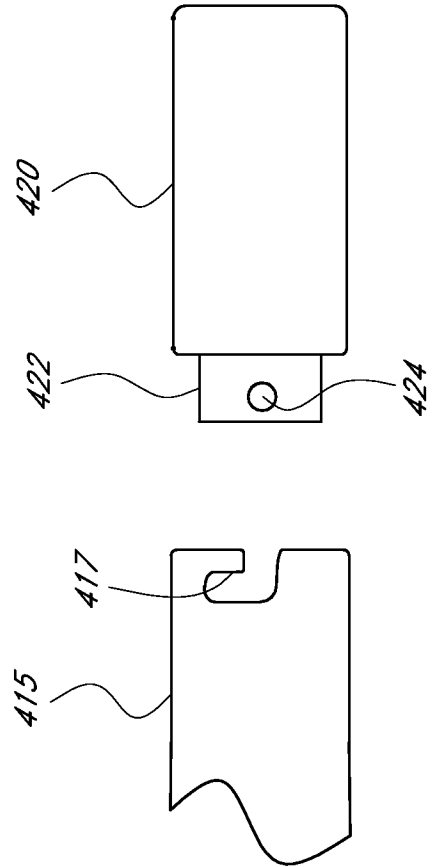
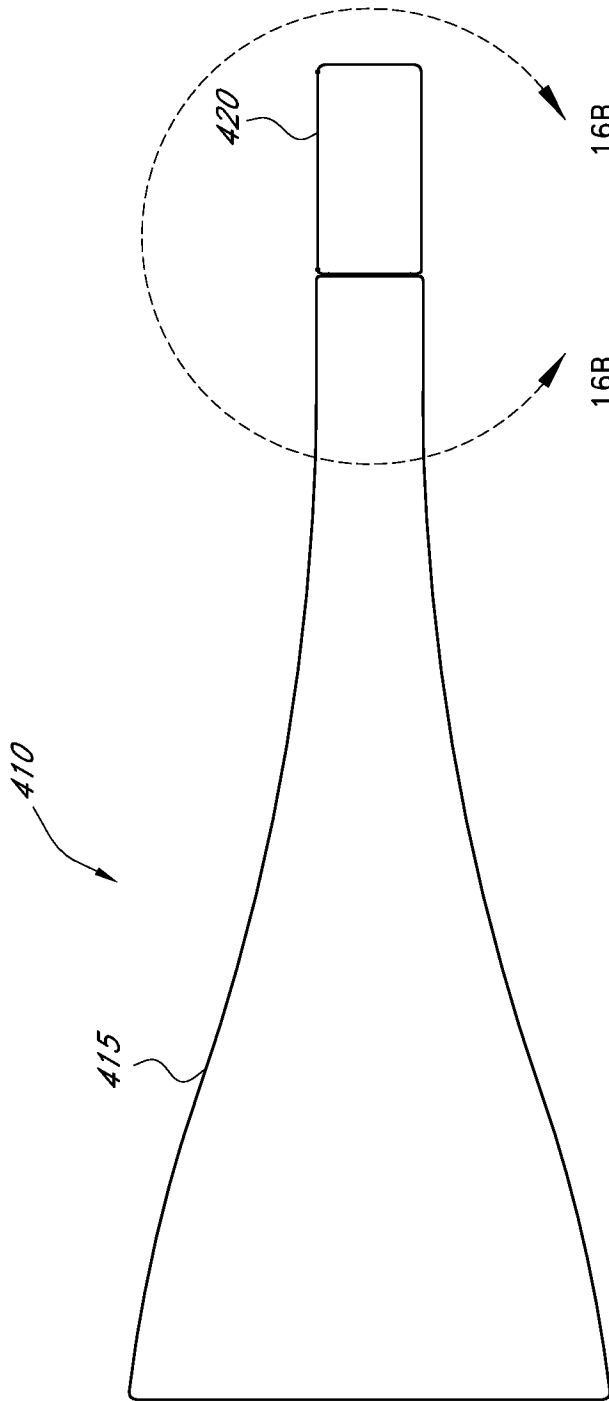

FIG. 16A

FIG. 16B

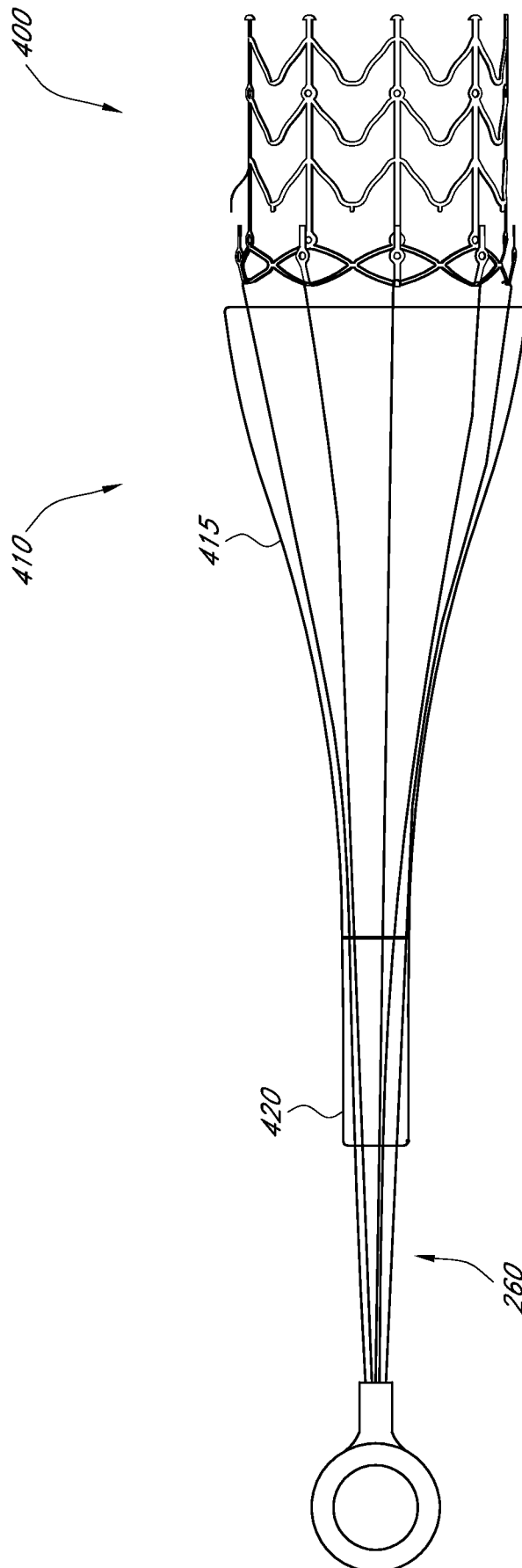

FIG. 17A

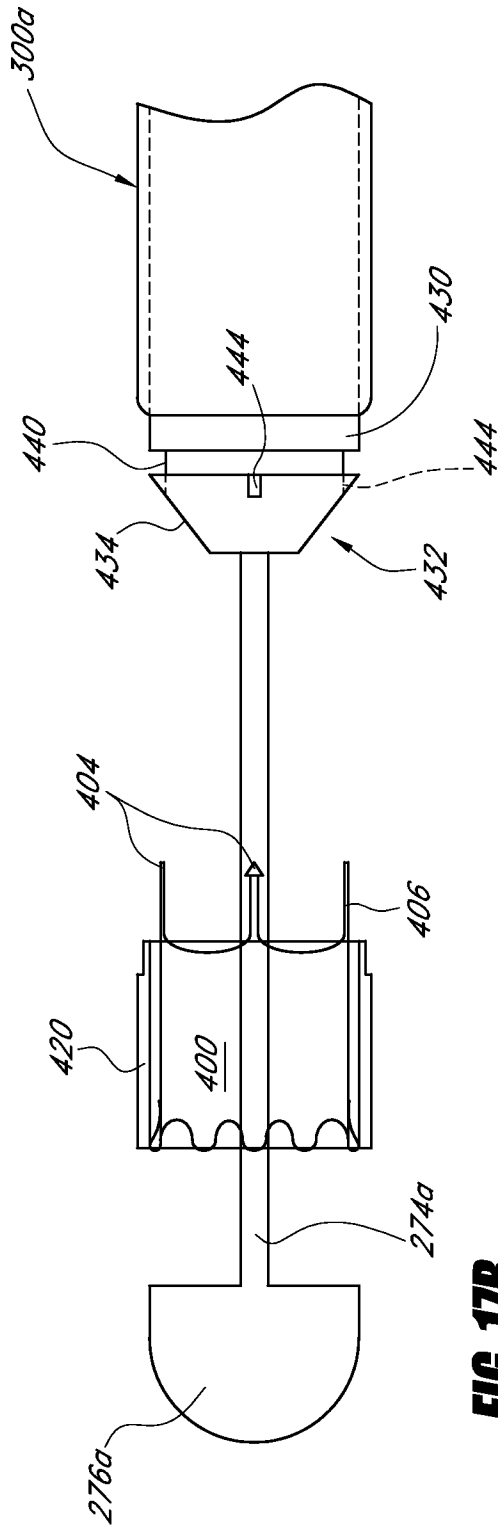

FIG. 17B

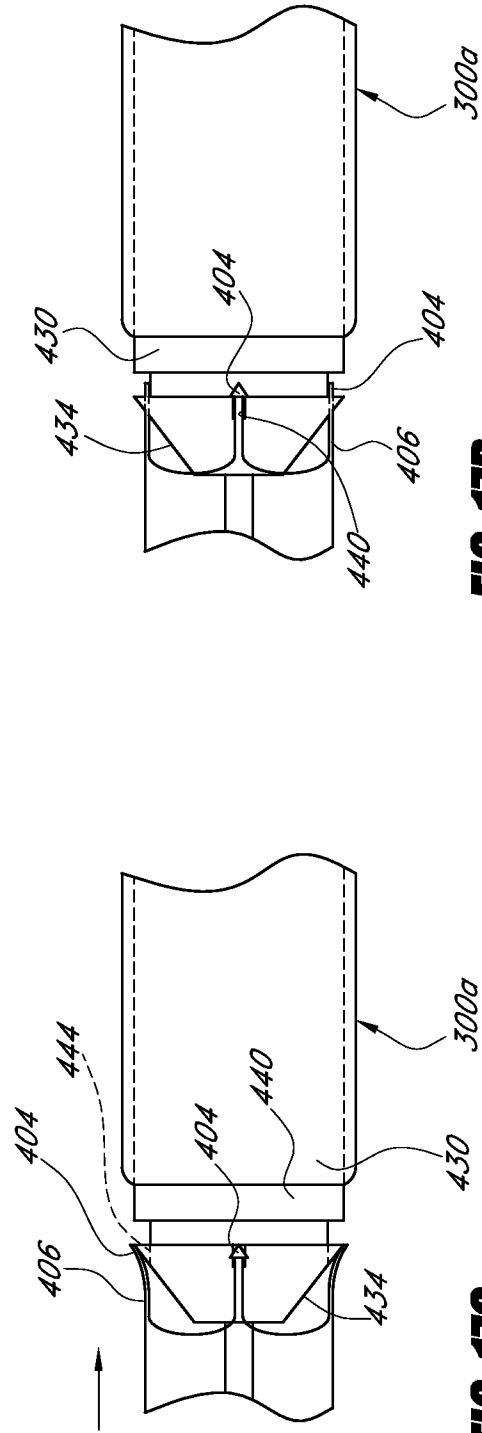

FIG. 17D

FIG. 17C

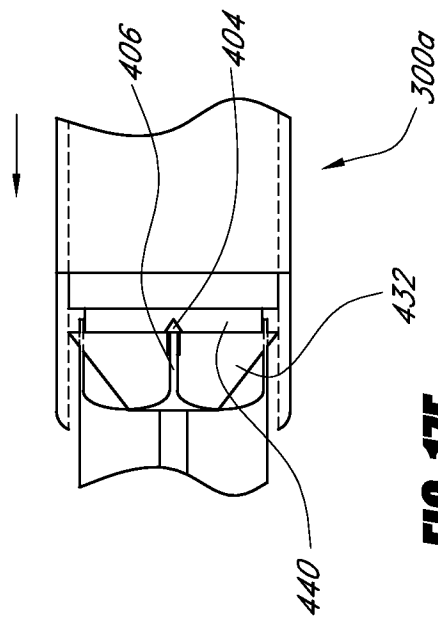

FIG. 17E

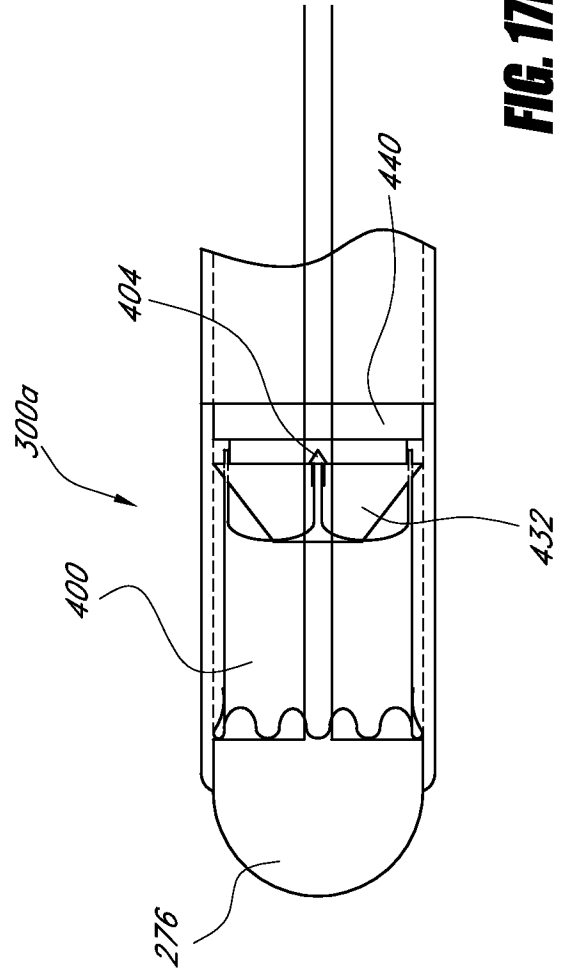

FIG. 17F