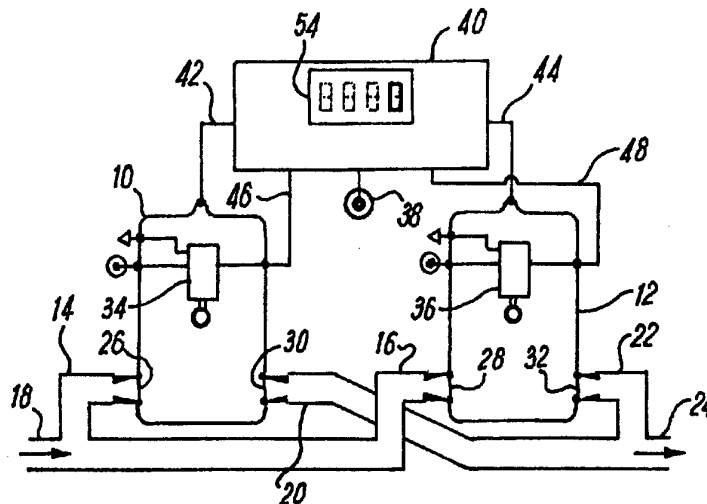




## INTERNATIONAL APPLICATION PUBLISHED UNDER THE PATENT COOPERATION TREATY (PCT)

<p>(51) International Patent Classification <sup>6</sup> : B08B 5/04, A47L 5/38, 7/00, F04F 5/20, 5/54, E21B 21/00, B24C 3/06</p>	A1	<p>(11) International Publication Number: <b>WO 95/18685</b></p> <p>(43) International Publication Date: 13 July 1995 (13.07.95)</p>
<p>(21) International Application Number: PCT/GB95/00013</p> <p>(22) International Filing Date: 5 January 1995 (05.01.95)</p> <p>(30) Priority Data: 9400156.7 6 January 1994 (06.01.94) GB 9407941.5 21 April 1994 (21.04.94) GB</p> <p>(71) Applicant (for all designated States except US): RICOM ENGINEERING LIMITED [GB/GB]; 10 Fleming Court, Clydebank Business Park, Clydebank, Glasgow G81 2DR (GB).</p> <p>(72) Inventors; and (75) Inventors/Applicants (for US only): CLARK, Eric, J. [GB/GB]; Shotlin Farm Cottage, Chapelton, Strathaven, Lanarkshire ML10 6TY (GB). FISHER, Malcolm [GB/GB]; 10 Earl Place, Bridge of Weir, Renfrewshire PA11 3HA (GB). LOUGHBRIDGE, Jeffrey [GB/GB]; 132 Kingsacre Road, Kings Park, Glasgow G44 3LU (GB).</p> <p>(74) Agent: MURGITROYD &amp; COMPANY; 373 Scotland Street, Glasgow G5 8QA (GB).</p>	<p>(81) Designated States: AM, AT, AU, BB, BG, BR, BY, CA, CH, CN, CZ, DE, DK, EE, ES, FI, GB, GE, HU, JP, KE, KG, KP, KR, KZ, LK, LR, LT, LU, LV, MD, MG, MN, MW, MX, NL, NO, NZ, PL, PT, RO, RU, SD, SE, SI, SK, TJ, TT, UA, US, UZ, VN, European patent (AT, BE, CH, DE, DK, ES, FR, GB, GR, IE, IT, LU, MC, NL, PT, SE), OAPI patent (BF, BJ, CF, CG, CI, CM, GA, GN, ML, MR, NE, SN, TD, TG), ARIPO patent (KE, MW, SD, SZ).</p> <p>Published With international search report.</p>	

(54) Title: LIQUID RECOVERY APPARATUS



## (57) Abstract

Liquid recovery apparatus comprises first and second liquid holding vessels (110, 112), a vacuum pump (156) adapted to apply a vacuum selectively to one or other of the vessels and control means (140) adapted to switch the vacuum from one vessel to the other when the liquid level in the one vessel reaches a maximum level, the liquid contained in the one vessel being discharged therefrom while liquid continues to be collected in the other vessel. The apparatus operates in a cyclic manner to continuously recover liquid into the vessels alternately. The liquid level is monitored by uppermost float valves (134, 136). Liquid discharge is facilitated by pressurising the vessel after the liquid reaches the uppermost level, the pressure being removed when the liquid falls to a lowermost level detected by lowermost level detectors (176, 178). The apparatus is pneumatically powered and controlled, and utilises a venturi type vacuum pump.

**FOR THE PURPOSES OF INFORMATION ONLY**

Codes used to identify States party to the PCT on the front pages of pamphlets publishing international applications under the PCT.

AT	Austria	GB	United Kingdom	MR	Mauritania
AU	Australia	GE	Georgia	MW	Malawi
BB	Barbados	GN	Guinea	NE	Niger
BE	Belgium	GR	Greece	NL	Netherlands
BF	Burkina Faso	HU	Hungary	NO	Norway
BG	Bulgaria	IE	Ireland	NZ	New Zealand
BJ	Benin	IT	Italy	PL	Poland
BR	Brazil	JP	Japan	PT	Portugal
BY	Belarus	KE	Kenya	RO	Romania
CA	Canada	KG	Kyrgystan	RU	Russian Federation
CF	Central African Republic	KP	Democratic People's Republic of Korea	SD	Sudan
CG	Congo	KR	Republic of Korea	SE	Sweden
CH	Switzerland	KZ	Kazakhstan	SI	Slovenia
CI	Côte d'Ivoire	LI	Liechtenstein	SK	Slovakia
CM	Cameroon	LK	Sri Lanka	SN	Senegal
CN	China	LU	Luxembourg	TD	Chad
CS	Czechoslovakia	LV	Latvia	TG	Togo
CZ	Czech Republic	MC	Monaco	TJ	Tajikistan
DE	Germany	MD	Republic of Moldova	TT	Trinidad and Tobago
DK	Denmark	MG	Madagascar	UA	Ukraine
ES	Spain	ML	Mali	US	United States of America
FI	Finland	MN	Mongolia	UZ	Uzbekistan
FR	France			VN	Viet Nam
GA	Gabon				

1     **"Liquid Recovery Apparatus"**

2

3     This invention relates to liquid recovery apparatus.  
4     The invention relates particularly but not exclusively  
5     to such apparatus for use in the recovery of spilled  
6     fluids, sludges and effluents, which may or may not  
7     contain solids, and for subsequently transferring them  
8     to another more convenient location such as a collector  
9     tank.

10

11     In its preferred form, the apparatus is powered and  
12     pneumatically controlled by compressed air, the suction  
13     being provided by a pneumatic ejector(s), working on  
14     venturi constant level suction principle with no moving  
15     parts, for subjecting a first collection vessel to sub  
16     atmospheric pressure (vacuum) whereby liquid is sucked  
17     into the first vessel. When the first vessel is full,  
18     discharge of the liquid therefrom is facilitated by  
19     subjecting the same vessel to positive pressure. While  
20     recovered liquid is being discharged from the first  
21     vessel, the vacuum is instantaneously switched to a  
22     second vessel and liquid recovery continues. Since  
23     suction is never lost, the invention gives continuous  
24     suction but with automatic intermittent discharge  
25     meaning that the operator does not have to wait to

1 continue operations while a holding tank is discharged.

2

3 This "multi-vessel" system will consist of at least two  
4 pressure vessels but may have more than two vessels  
5 depending on the nature and amount of material to be  
6 recovered.

7

8 The apparatus is used in a similar fashion to a  
9 domestic household vacuum cleaner. The user will  
10 "sweep up" the spillage using a suitably designed  
11 suction head which will be connected to the invention  
12 by means of a flexible suction hose. A similar such  
13 hose will be employed to carry the discharge medium to  
14 the desired location.

15

16 The apparatus is intrinsically safe due to the fact  
17 that it is air powered, thus eliminating the  
18 requirement for detailed safety certification in the  
19 field of use.

20

21 In its preferred form, the invention is pneumatically  
22 controlled and powered, so that it does not present an  
23 explosion risk. Accordingly, it is envisaged that it  
24 may be used in explosive and hazardous environments  
25 examples of which being underground mines, offshore or  
26 onshore drilling installations for oil, gas or the  
27 like, or empty fuel silos. It might also be employed  
28 advantageously in non-hazardous environments, in which  
29 case it may be controlled and powered by other means,  
30 including electrical and/or hydraulic means

31

32 A number of types of liquid recovery apparatus are  
33 known for use in the types of liquid recovery  
34 application for which the present invention is  
35 particularly intended, as follow:-

36

1 1. Double diaphragm reciprocating pumps. A number of  
2 makes and variations of this type of equipment exist.

3

4 2. Venturi operated (constant suction level) pumps,  
5 which have been in existence for over forty years.

6 Pumps of this type are generally known as CP72 type  
7 pumps.

8

9 3. EP-B-0 162 074 discloses liquid recovery apparatus  
10 in which liquid is collected in a single vessel, and is  
11 automatically discharged when the vessel is full,  
12 whereafter liquid recovery continues. This apparatus  
13 is essentially a combination, in working principle, of  
14 a CP72 pump (for suction) and a double diaphragm  
15 reciprocating pump (for discharge) with a holding  
16 vessel set in between.

17

18 These existing types of apparatus have the following  
19 advantages (a) and disadvantages (d):-

20

21 1a) The double diaphragm reciprocating pumps provide  
22 continuous suction and discharge and have a fairly  
23 simple internal (albeit antiquated) control  
24 system.

25

26 1d) The construction of these pumps is a limiting  
27 feature insofar that if a piece of debris is  
28 picked up (eg stray bolt), it can cause severe  
29 internal damage frequently resulting in having to  
30 replace the pump casing. A filter is therefore  
31 required on the suction line to overcome this  
32 problem which limits the actual suction ability.  
33 Operators are known to dispose of these filters in  
34 the attempt to increase suction.

35

36 The mechanical method in which the suction is

1 created (reciprocating diaphragms) also causes a  
2 minor "sinusoidal" suction and discharge effect.  
3 The created suction is therefore not at a constant  
4 level and, in order to work effectively, the  
5 suction head ideally is required to be submerged  
6 in the fluid medium which is being recovered.

7

8 2a) CP72 sludge pumps have venturi (constant level)  
9 suction and very few moving parts.

10

11 2d) The CP72 sludge pump has a very antiquated ball-  
12 float pneumatic control system which is easily  
13 damaged by any recovered fluids other than non-  
14 contaminated water. Repair down-time is therefore  
15 quite high.

16

17 The single pressure vessel principle of the CP72  
18 pump also means that there is alternate suction  
19 and discharge. That is to say that the vessel is  
20 subject to vacuum and when full of recovered fluid  
21 the vacuum ceases and the vessel is subjected to a  
22 positive pressure which forces the recovered fluid  
23 to another location by means of a discharge hose.  
24 This happens fairly quickly and can cause a  
25 hazardous "whipping" effect on the discharge hose.  
26 The rapid successive suction and discharge also  
27 causes frequent breakdown on the control system.

28

29 3a) Apparatus of the type disclosed in EP-B-0 162 074  
30 has venturi (constant level) suction and modern  
31 pneumatic control system.

32

33 3d) Such apparatus employs double diaphragm  
34 reciprocating pumps for discharge purposes and,  
35 similar to (1d), will be easily damaged if any  
36 debris enters the holding vessel. A filter is

1           therefore employed on the suction line to overcome  
2           this problem, but it is known that these are  
3           frequently removed by operators and disposed of to  
4           help improve suction ability. The  
5           repair/servicing down-time for this equipment is  
6           therefore quite high.

7  
8           Similar to (2d), the single holding vessel  
9           principle of this apparatus means that there is  
10          alternate suction and discharge. That is to say  
11          that the vessels subject to vacuum and when full  
12          of recovered fluid the vacuum ceases and the  
13          discharge pump removes the recovered fluid from  
14          the vessel, transferring it to another location by  
15          means of a discharge hose.

16  
17          The discharge cycle for this apparatus has a  
18          preset time which is normally suited to fluids  
19          which have similar properties to water. This  
20          means that fluids which are lighter or less  
21          viscous than water will be discharged very quickly  
22          resulting in air being pumped into the discharge  
23          hose which may create a hazardous whiplash effect  
24          when fluid re-enters the discharge hose on the  
25          next discharge cycle. Equally, fluids which are  
26          heavier or more viscous than water (or where the  
27          discharge fluid has to be raised above a  
28          significant height) will not be given sufficient  
29          time to entirely empty the holding vessel.

30  
31          It is an object of the present invention to provide  
32          liquid recovery apparatus which obviates or mitigates  
33          one or more of the foregoing disadvantages of existing  
34          types of apparatus.

35  
36          In accordance with a first aspect of the present

1 invention there is provided apparatus for recovering  
2 liquids, comprising first and second vessels for  
3 liquid, vacuum pump means for applying a vacuum  
4 selectively to the first and second vessels, each  
5 vessel having an inlet for recovered liquid which  
6 includes valve means restricting liquid exit from the  
7 vessel, and an outlet through which liquid is  
8 discharged from the vessel, the outlet including valve  
9 means which restricts liquid entry to the vessel, and a  
10 conduit connected to said inlets to convey recovered  
11 liquid to the vessels.

12

13 Preferably, the apparatus further includes control  
14 means including switching means adapted to switch the  
15 applied vacuum from one vessel to the other in response  
16 to a control signal indicating that the liquid level in  
17 said one container has reached a predetermined maximum  
18 level and to cause the liquid collected in said one  
19 container to be discharged via said outlet of said one  
20 vessel.

21

22 More preferably, said control means is adapted to apply  
23 said vacuum is alternately to said first and second  
24 vessels in a cyclical manner such that recovered liquid  
25 is drawn into one of the vessels via its inlet whilst  
26 any previously recovered liquid is discharged from the  
27 other vessel via its outlet, the vacuum being switched  
28 from said one vessel to said other vessel when the  
29 recovered liquid in said one vessel rises to said  
30 predetermined level, such that recovered liquid is  
31 drawn into said other vessel whilst the previously  
32 recovered liquid is discharged from said one vessel.

33

34 Most preferably, said control means comprises pneumatic  
35 control means.

36

1 Preferably also, said control signal is generated by  
2 first liquid level sensors located in each of said  
3 vessels. Said sensors preferably comprise float valves.  
4

5 Preferably also, said vacuum pump comprises a venturi  
6 ejector type pump.  
7

8 Preferably also, the valve means of said inlets and  
9 outlets comprise one way check valves.  
10

11 Alternatively, the valve means of said inlets and  
12 outlets comprise pneumatically actuated valves.  
13 Preferably, said pneumatically actuated valves are  
14 normally closed valves.  
15

16 In one embodiment of the invention, the period during  
17 which liquid is discharged from said one vessel is  
18 determined by timer means.  
19

20 Preferably, said control means is further adapted to  
21 cause a pressure to be applied alternately to the  
22 interiors of said first and second vessels when  
23 recovered liquid is to be discharged therefrom.  
24

25 More preferably, said control means is further adapted  
26 to cause said pressure to be applied to the interior of  
27 said one vessel when the liquid level in said one  
28 vessel reaches said first level.  
29

30 In a preferred embodiment of the invention, said  
31 control means is further adapted to cause said inlet  
32 valve means of said one vessel to close, said outlet  
33 valve means of said one vessel to open, said inlet  
34 valve means of said other vessel to open and said  
35 outlet valve means of said other vessel to close when  
36 the liquid level in said one vessel reaches said first

1 level.

2

3 Preferably also, said first and second vessels each  
4 includes second level detector means for detecting when  
5 the level of recovered liquid in the vessel falls below  
6 a second, lower, predetermined level.

7

8 Most preferably, said control means is further adapted  
9 to apply a pressure to the interior of said one vessel  
10 while liquid is being discharged therefrom and to  
11 remove said applied pressure from said one vessel when  
12 the liquid level in said one vessel falls below said  
13 second level.

14

15 Preferably, said outlets of said first and second  
16 vessels are connected to a common discharge conduit,  
17 said discharge conduit including discharge valve means.

18

19 Preferably said control means is further adapted to  
20 cause said discharge valve means to close when the  
21 liquid level in said one vessel falls below a lowermost  
22 predetermined level and to open when the liquid level  
23 in said other vessel exceeds an uppermost predetermined  
24 level.

25

26 Preferably, the apparatus further includes counter  
27 means adapted to be incremented at a predetermined  
28 point in the cyclical operation of the apparatus. Most  
29 preferably, said counter means is incremented when the  
30 vacuum is switched from one of said first and second  
31 vessels to the other.

32

33 Preferably also, the apparatus further includes  
34 manually operable control means whereby recovered  
35 liquid may be discharged from said first and/or second  
36 vessels.

1 In accordance with a second aspect of the invention  
2 there is provided apparatus for recovering liquids,  
3 comprising at least a first vessel for liquid, vacuum  
4 pump means for applying a vacuum selectively to said at  
5 least one vessel, said at least one vessel having an  
6 inlet for recovered liquid which includes valve means  
7 restricting liquid exit from the vessel, and an outlet  
8 through which liquid is discharged from the vessel, the  
9 outlet including valve means which restricts liquid  
10 entry to the vessel, and a conduit connected to said  
11 inlets to convey recovered liquid to the vessel, and  
12 further including first liquid level detecting means  
13 for detecting when the liquid level in said at least  
14 one vessel reaches an uppermost predetermined level and  
15 second liquid level detecting means for detecting when  
16 the liquid level in said at least one vessel reaches a  
17 lowermost predetermined level, and control means  
18 responsive to said first and second level detecting  
19 means and adapted to remove said vacuum from said at  
20 least one vessel and to cause liquid contained therein  
21 to be discharged from said vessel when said liquid  
22 level reaches said uppermost predetermined level and to  
23 cause said vacuum to be reapplied to said vessel when  
24 said liquid level falls to said lowermost predetermined  
25 level.

26

27 Embodiments of the invention will now be described, by  
28 way of example only, with reference to the accompanying  
29 drawings in which:

30

31 Fig. 1 is a schematic representation of liquid  
32 recovery apparatus in accordance with a first  
33 embodiment of the invention;

34 Fig. 2 is a schematic, perspective drawing of a  
35 suction head attached to a liquid recovery conduit  
36 for use with the present invention;

1 Figs. 3 to 8 are more detailed schematic  
2 representations of the apparatus of Fig. 1  
3 illustrating the cyclical operation of the  
4 apparatus;  
5 Fig. 9 is a schematic representation of liquid  
6 recovery apparatus in accordance with a second  
7 embodiment of the invention;  
8 Figs. 10 to 19 are more detailed schematic  
9 representations of the apparatus of Fig. 9  
10 illustrating the cyclical operation of the  
11 apparatus;  
12 Fig. 20 is a schematic representation of liquid  
13 recovery apparatus in accordance with a third  
14 embodiment of the invention;  
15 Fig. 21 is a more detailed schematic  
16 representation of the apparatus of Fig. 20;  
17 Fig. 22 is a schematic front view illustrating the  
18 physical arrangement of an example of a liquid  
19 recovery apparatus in accordance with the second  
20 or third embodiments of the invention;  
21 Fig. 23 is a schematic side view of the apparatus  
22 of Fig. 22; and  
23 Fig. 24 is a schematic top view of the apparatus  
24 of Fig. 22.

25

26 Referring now to the drawings, Fig. 1 shows the general  
27 arrangement of a first embodiment of liquid recovery  
28 apparatus in accordance with the invention. The  
29 apparatus is powered by compressed air and is  
30 pneumatically controlled.

31

32 The apparatus comprises first and second vessels 10 and  
33 12 for the collection of recovered liquid. Each of the  
34 vessels has an inlet 14, 16 connected to a common inlet  
35 conduit 18, and an outlet 20, 22 connected to a common  
36 discharge conduit 24. Each of the inlets 14, 16 and

1 outlets 20, 22 has a one way check valve 26, 28, 30, 32  
2 respectively associated therewith. Each of the vessels  
3 10, 12 also has a float valve 34, 36 located in its  
4 interior adjacent the upper end of the vessels for  
5 detecting when liquid in the vessels reaches a  
6 predetermined uppermost level.

7  
8 The apparatus is powered by an air supply 38 which is  
9 connected to a control box 40. The air supply serves to  
10 power a vacuum source (not shown, described in greater  
11 detail below) for liquid recovery and to operate the  
12 pneumatic control means of the apparatus. The control  
13 box 40 is connected to each of the vessels 10, 12 by  
14 means of air lines 42, 44 communicating with the  
15 interiors of the vessels to apply a vacuum thereto for  
16 liquid recovery and to pressurise the vessels to  
17 facilitate the discharge of recovered liquid, and by  
18 means of pneumatic control lines 46, 48 connected to  
19 the float valves 34, 36.

20  
21 The pneumatic control means of the apparatus operates  
22 such that vacuum is applied to one of the vessels 10,  
23 12 until the float valve of the vessel operates to  
24 indicate that recovered liquid has reached a  
25 predetermined level. At this point the vacuum is  
26 switched to the other vessel so that liquid continues  
27 to be sucked into the other vessel while the previously  
28 recovered liquid is discharged from the first vessel.  
29 The apparatus thus cycles between the first and second  
30 vessels so that liquid recovery can continue  
31 substantially without interruption during operation of  
32 the apparatus. The operation of the apparatus will be  
33 described in greater detail below.

34  
35 Fig. 2 illustrates a suction head 50 for connection to  
36 the inlet conduit 18, for the recovery of liquid 52.

1 In general working principle the vacuum pump of the  
2 apparatus is not unlike the idea of the CP72 sludge  
3 pump described above. However it differs principally  
4 by virtue of the fact that it has two liquid holding  
5 vessels. This means that in working operation one  
6 vessel will be subjected to a vacuum and when this  
7 vessel is full of recovered fluid, the vacuum is  
8 automatically and instantaneously transferred to the  
9 other tank.

10

11 When the currently active vessel is full the recovered  
12 fluid is transferred to another location by subjecting  
13 the vessel to positive pressure for a set period of  
14 time determined by a pneumatic timer within the control  
15 circuitry, during which period the vacuum is  
16 transferred to the other vessel. Therefore the  
17 apparatus will always provide continuous suction for  
18 the operator. A manual discharge valve is also fitted  
19 for the purpose of giving the operator the chance to  
20 totally empty the vessels when operations are complete.

21

22 The control box 40 includes a resettable pneumatic  
23 counter 54 linked to the control circuitry. The counter  
24 54 increments by one each time the vessels change over.  
25 By knowing the volume of each tank (suitably 20 gallons  
26 (imp) approximately), the counter can be used to  
27 provide an indication of the volume of the spilled  
28 fluid which has been recovered.

29

30 As will be described in more detail below in relation  
31 to a second embodiment of the invention, the apparatus  
32 may be modified to include ball float valves in the  
33 bottom of the vessels to detect when the vessels have  
34 been emptied. This eliminates the requirement for a  
35 pneumatic timer. In addition to this, pneumatically  
36 actuated valves may be added to replace the one way

1 "Check" valves 26, 28, 30, 32 on the vessel suction and  
2 discharge ports 14, 16, 18, 20 which in this example  
3 are sealed by the combination of gravity and the action  
4 of pressure/vacuum. Such modifications would also  
5 require appropriate modifications of the control  
6 circuitry.

7  
8 There now follows a more detailed description of the  
9 working principle of the first embodiment of the  
10 invention, with reference to Figs 3 to 8 of the  
11 drawings.

12  
13 The apparatus gets its vacuum by means of a venturi  
14 ejector 56. In a venturi system of this type the  
15 exhaust port has a smaller area than the inlet area.  
16 Because the air volumetric flow rate is the same at  
17 each port of the venturi, the actual air velocity  
18 increases resulting in a loss of pressure at the  
19 exhaust. Hence a vacuum is created.

20  
21 The apparatus operates in a cyclical manner as shall  
22 now be described.

23  
24 Stage 1

25  
26 With reference to Fig. 3, the suction line 58 from the  
27 venturi ejector 56 passes through a purge valve 60 and  
28 a transfer valve 62 and hence a vacuum is applied to  
29 the first vessel 10. The outlet port one way check  
30 valve 30 of the first vessel 10 is pulled closed by the  
31 vacuum whilst the inlet port check valve 26 is sucked  
32 open. As the operator applies the suction head 50 to  
33 the spillage 52, fluid is sucked into the first vessel  
34 10 which then begins to fill. At this stage nothing  
35 else is happens within the rest of the apparatus.

36

## 1 Stage 2

2

3 When the first vessel 10 is full as shown in Fig 4, the  
4 ball float 64 attached to the float valve 34 is forced  
5 up causing the float valve 34 to change from position 1  
6 to position 2. This sends a pneumatic pilot signal to  
7 transfer valve 62 causing it to change to position 2  
8 and to a shuttle valve 66 which also changes to  
9 position 2. The signal out of the shuttle valve 66  
10 causes the pneumatic counter 54 to advance by one and  
11 causes a discharge control valve 68 to change to  
12 position 2. As the transfer valve 62 is now in  
13 position 2, the vacuum from the venturi ejector 56 and  
14 purge valve 60 has now been transferred to the second  
15 vessel 12 which subsequently begins to fill. The  
16 outlet port one way check valve 32 in the second  
17 vessel 12 is pulled closed by the vacuum whilst the  
18 inlet port check valve 28 is sucked open. Meanwhile,  
19 because the discharge control valve 68 is in position  
20 2, an air supply is sent to the first vessel 10 via the  
21 transfer valve 62 causing the recovered fluid to  
22 discharge. The inlet one way check valve 26 in the  
23 first vessel 10 will be forced to close whilst the  
24 outlet check valve 30 will be forced to open due to the  
25 discharging fluid. The air supply from the discharge  
26 control valve 68 is also supplied to a pneumatic timer  
27 70 which begins to charge by means of a reservoir 72.

28

## 29 Stage 3

30

31 After a pre-determined period, the reservoir 72 of the  
32 pneumatic timer 70 is full causing the timer 70 to  
33 change to position 2 as can be seen in Fig 5. The  
34 timer sends a pilot signal to the discharge control  
35 valve 68 which then reverts back to position 1. This  
36 has the effect of resetting the timer 70 and stopping

1 the air supply to the first vessel 10 which now should  
2 have all of its contents discharged. Because the timer  
3 70 has reset itself, it now reverts back to position 1.  
4 The float valve 34 inside the first vessel 10 will also  
5 have reverted back to position 1. This means that the  
6 pilot signals which were sent from float valve 34 to  
7 transfer valve 62 and discharge control valve 68 will  
8 have exhausted to atmosphere. Whilst all of this is  
9 happening, the second vessel 12 currently being  
10 subjected to vacuum continues to fill.

11

12 Stage 4

13

14 When the second vessel 12 is full as shown in Fig 6,  
15 the ball float 74 attached to the float valve 36 of the  
16 second vessel 12 is forced up causing this float valve  
17 36 to change from position 1 to position 2. This sends  
18 a pneumatic pilot signal to the transfer valve 62  
19 causing it to change to position 1 and to the shuttle  
20 valve 66 which also changes to position 1. The signal  
21 out of the shuttle valve 66 causes the pneumatic  
22 counter 54 to advance by one and causes the discharge  
23 control valve 68 to change to position 2. As the  
24 transfer valve 62 is now in position 1, the vacuum from  
25 the venturi ejector 56 and the purge valve 60 has now  
26 been transferred to the first vessel 10 which  
27 subsequently begins to fill. The outlet port one way  
28 check valve 30 of the first vessel 10 is pulled closed  
29 by the vacuum whilst the inlet port check valve 26 is  
30 sucked open. Meanwhile, because the discharge control  
31 valve 68 is in position 2, an air supply is sent to the  
32 second vessel 12 via the transfer valve 62 causing the  
33 recovered fluid to discharge. The inlet one way check  
34 valve 28 of the second vessel 12 will be forced to  
35 close whilst the outlet check valve 32 will be forced  
36 to open due to the discharging fluid. The air supply

1 from the discharge control valve 68 is also supplied to  
2 the timer 70 which begins to charge by means of its  
3 reservoir 72.

4

5 Stage 5

6

7 After the pre-determined period, the reservoir 72 is  
8 full causing the timer 70 to move to position 2 as can  
9 be seen in Fig 7. The timer 70 sends a pilot signal to  
10 the discharge control valve 68 which then reverts back  
11 to position 1. This has the effect of resetting the  
12 timer 70 and stopping the air supply to the second  
13 vessel 12 which now should have all of its contents  
14 discharged. Because the timer 70 has reset itself, it  
15 now reverts back to position 1. This means that the  
16 pilot signals which were sent from float valve 36 of  
17 the second vessel 12 to the transfer valve 62 and the  
18 discharge control valve 68 will have exhausted to  
19 atmosphere. Whilst all of this is happening, the first  
20 vessel 10 currently being subjected to vacuum continues  
21 to fill. The cycle now repeats itself.

22

23 Manual Discharge

24

25 The entire operational cycle is completely automatic.  
26 However, once the operator has completed his spillage  
27 recovery task, he may wish to discharge the remainder  
28 of the contents held within either of the holding  
29 vessels 10, 12 of the apparatus. With reference to Fig  
30 8, the purge valve 60 is pressed so that it changes to  
31 position 2. This has the effect of applying positive  
32 pressure to the vessel which is currently being  
33 subjected to vacuum (the first vessel 10 in this case).  
34 When all of the fluid has been discharged and the  
35 operator is finished, he can then release the button on  
36 purge valve 60 which returns to position 1. The

1 positive pressure ceases and vacuum is returned to the  
2 first vessel 10 (in this example). The main air supply  
3 38 may then be removed from the apparatus at this time  
4 if the operator has finished his task.

5

6 A second, preferred embodiment of liquid recovery  
7 apparatus in accordance with the invention will now be  
8 described with reference to Figs. 9 to 19 of the  
9 drawings.

10

11 Fig. 9 shows the general arrangement of the second  
12 embodiment in twin vessel form. This is generally  
13 similar in structure and general working principle to  
14 the first embodiment, and like or equivalent features  
15 of the second embodiment are designated by reference  
16 numerals corresponding to those used in the first  
17 embodiment, prefixed "1".

18

19 The principal differences between the first and second  
20 embodiments are as follow:

21 (a) The first and second vessels 110 and 112 of the  
22 second embodiment each includes a second float valve  
23 176, 178 located adjacent the bottoms of the vessels  
24 for detecting when the liquid level in the vessels  
25 falls to a predetermined minimum level. These float  
26 valves form part of the control means of the apparatus,  
27 in place of the timer 70 of the first embodiment, and  
28 have associated control lines connected to the control  
29 box 140.

30 (b) The inlet and outlet one way check valves 26, 28,  
31 30, 32 of the first embodiment are replaced by  
32 pneumatically controlled valves 126, 128, 130, 132 in  
33 the second embodiment, with corresponding control lines  
34 connected to the control box 140.

35

36 The apparatus is again powered by compressed air and

1 pneumatically controlled.

2

3 There now follows a more detailed description of the  
4 working principle of the second embodiment of the  
5 invention, with reference to Figs. 10 to 19 of the  
6 drawings

7

8 The apparatus again gets its vacuum by means of a  
9 venturi ejector 156, as in the first embodiment.

10

11 The apparatus operates in a cyclical manner as shall  
12 now be described.

13

14 Stage 1 (Fig 10)

15

16 With reference to Fig 10, air is supplied and passes  
17 through the manual purge valve 160 and sends a  
18 pneumatic pilot signal to a venturi control valve 180  
19 causing it to change position 2. Air from the purge  
20 valve 160 is also supplied to the venturi ejector 156  
21 causing a vacuum to be created through the venturi  
22 control valve 180. The vacuum passes through the  
23 transfer valve 162 which is shown in position 1  
24 allowing the vacuum to be applied to the first vessel  
25 110. A suction/discharge line control valve 182 is  
26 synchronised with the transfer valve 162 such that the  
27 air supply on the suction/discharge line control valve  
28 182 is in position 1 giving a valve open signal (VOS)  
29 to the inlet valve 126 of the first vessel 110 and the  
30 outlet valve 132 of the second vessel 112, and a valve  
31 close signal (VCS) to the outlet valve 130 of the first  
32 vessel 110 and the inlet valve 128 of the second vessel  
33 112. As the operator applies the suction head 50 (Fig.  
34 2) to the spillage 52, fluid is sucked via the inlet  
35 valve 126 into the first vessel 110 which then begins  
36 to fill. At this stage nothing else happens within the

1 rest of the apparatus.

2

3 Stage 2 (Fig 11)

4

5 As the first vessel 112 is now filling, the fluid level  
6 eventually forces the lower float valve 176 of the  
7 first vessel 110 to change over to position 2 as shown  
8 in Fig 11. This results in a pilot signal being sent  
9 to an AND valve 184. The AND valve 184 requires two  
10 input signals before an output pilot signal is  
11 generated. Therefore at this stage nothing else  
12 happens within the rest of the apparatus.

13

14 Stage 3 (Fig 12)

15

16 The first vessel 110 continues to fill until the fluid  
17 level reaches its upper float valve 134 causing this  
18 valve to change over to position 2 as shown in Fig 12.  
19 The upper float valve 134 sends a pilot signal to a  
20 first OR valve 186, making it change over to position  
21 1. This allows the AND valve 184 to receive a second  
22 input signal letting it give an output pilot signal to  
23 the transfer valve 162, to a second OR valve 188 and to  
24 the suction/discharge line control valve 182 with each  
25 of these valves changing over to position 2. The air  
26 supply on the suction/discharge valve 182 is now  
27 changed over giving a valve close signal (VCS) to  
28 valves 126 and 132 and a valve open signal (VOS) to  
29 valves 130 and 128. Because the transfer valve 162 has  
30 also changed to position 2, vacuum has been transferred  
31 to the second vessel 112 which begins to fill with  
32 fluid via valve 128. Equally, a pressure discharge  
33 valve 190 has changed to position 2 due to the output  
34 pilot signal from the second OR valve 188. An air  
35 supply from the pressure discharge valve 190 also  
36 passes through the transfer valve 162 and is used to

1     pressurise the first vessel 110 causing the recovered  
2     fluid to be discharged into the discharge line 122 via  
3     valve 132. The discharging fluid also passes through a  
4     discharge line exit valve 192 which receives a valve  
5     open signal from the second OR valve 188. The air  
6     supply from the transfer valve 162 is also used as a  
7     pilot signal to a pressure sensing diaphragm valve 194  
8     which changes to position 2 causing a further pilot  
9     signal to be sent to the first OR valve 188.

10

11     Stage 4 (Fig 13)

12

13     As the fluid level drops in the first vessel 110, the  
14     upper float valve 134 returns to position 1 as shown in  
15     Fig 13. However, because the first vessel 110 is still  
16     pressurised, the pressure sensing diaphragm valve 194  
17     continues to send a pilot signal to the first OR valve  
18     186 which changes to position 2 and hence the second  
19     signal to the AND valve 184 is maintained as is the  
20     pilot signal to the pressure discharge valve 190 which  
21     remains in position 2. Therefore, the first vessel 110  
22     continues to be pressurised and the recovered fluid  
23     continues to discharge via valve 130 and discharge line  
24     exit valve 192. Meantime, the second vessel 112  
25     continues to fill and the fluid level eventually forces  
26     the lower float valve 178 of the second vessel 112 to  
27     change over to position 2 as shown in Fig 13. This  
28     results in a pilot signal being sent to the second AND  
29     valve 196. The second AND valve 196 requires two input  
30     signals before an output pilot signal is generated.

31

32     Stage 5 (Fig 14)

33

34     Eventually the fluid level in the first vessel 110  
35     falls low enough to allow its lower float valve 176 to  
36     change back to position 1 stopping one of the pilot

1 signals to the first AND valve 184 as shown in Fig 14.  
2 The pilot signals to the pressure discharge valve 190  
3 and discharge line exit valve 192 are therefore ceased  
4 allowing the pressure discharge valve 190 to return to  
5 position 1 and discharge line exit valve 192 to close  
6 under its internal spring mechanism. The first vessel  
7 110 ceases from being pressurised so that the pressure  
8 sensing diaphragm valve 194 returns to position 1.  
9 Discharge line exit valve 192 is required to prevent  
10 liquid in the discharge hose siphoning back into either  
11 of the vessels. Meantime, the second vessel 112  
12 continues to fill.

13

14 Stage 6 (Fig 15)

15

16 The second vessel 112 continues to fill until the fluid  
17 level reaches its upper float valve 136 causing this  
18 valve to change over to position 2 as shown in Fig 15.  
19 The upper float valve 136 sends a pilot signal to a  
20 third OR valve 198 making it change over to position 1.  
21 This allows the second AND valve 196 to receive a  
22 second input signal letting it give an output pilot  
23 signal to the transfer valve 162, to the second OR  
24 valve 188 and to the suction/discharge line control  
25 valve 192, with each of these valves changing over to  
26 position 1. The air supply on the suction/discharge  
27 line control valve 182 is now changed over giving a  
28 valve close signal (VCS) to valves 130 and 128 and a  
29 valve open signal (VOS) to valves 126 and 132. Because  
30 the transfer valve 162 has also changed to position 1,  
31 vacuum has been transferred to the first vessel 110  
32 which begins to fill with fluid via valve 114.  
33 Equally, the pressure discharge valve 190 has changed  
34 to position 2 due to the pilot signal from the second  
35 OR valve 188. At this stage, the pulse counter 154  
36 increments by one indicating the completion of a cycle

1 of operation in which both the first and second vessels  
2 have been filled with recovered liquid. An air supply  
3 from the pressure discharge valve 190 also passes  
4 through the transfer valve 162 and is used to  
5 pressurise the second vessel 112 causing the recovered  
6 fluid to be discharged into the discharge line 122 via  
7 valve 132. The discharging fluid also passes through  
8 the discharge line exit valve 192 which receives a  
9 valve open signal from the second OR valve 188. The  
10 air supply from the transfer valve 162 is also used as  
11 a pilot signal to a second pressure sensing diaphragm  
12 valve 200 which changes to position 2 causing a further  
13 pilot signal to be sent to the third OR valve 198.

14

15 Stage 7 (Fig 16)

16

17 As the fluid level drops in the second vessel 112, its  
18 upper float valve 136 returns to position 1 as shown in  
19 Fig 16. However, because the second vessel 112 is  
20 still pressurised, the second pressure sensing  
21 diaphragm valve 200 continues to send a pilot signal to  
22 the third OR valve 198 which changes to position 2 and  
23 hence the second signal to the second AND valve 196 is  
24 maintained as is the pilot signal to the pressure  
25 discharge valve 190 which remains in position 2.  
26 Therefore, the second vessel 112 continues to be  
27 pressurised and the recovered fluid continues to  
28 discharge via valve 132 and discharge line exit valve  
29 192.

30

31 Meantime, the first vessel 110 continues to fill and  
32 the fluid level eventually forces its lower float valve  
33 176 to change over to position 2 as shown in Fig 16.  
34 This results in a pilot signal being sent to the first  
35 AND valve 184 which requires two input signals before  
36 an output pilot signal is generated.

1 Stage 8 (Fig 17)

2

3 Eventually the fluid level in the second vessel 112  
4 falls low enough to allow its lower float valve 178 to  
5 change back to position 1 stopping one of the pilot  
6 signals to the second AND valve 196 as shown in Fig 17.  
7 The pilot signals to the pressure discharge valve 190  
8 and discharge line exit valve 192 are therefore ceased  
9 allowing the pressure discharge valve 190 to return to  
10 position 1 and discharge line exit valve 192 to close  
11 under its internal spring mechanism. The second vessel  
12 112 ceases from being pressurised so that the second  
13 pressure sensing diaphragm valve 200 returns to  
14 position 1. The first vessel 110 continues to fill.

15

16 The cycle now continues to repeat itself.

17

18 Manual Discharge (Figs 18 & 19)

19

20 The entire operational cycle is completely automatic.  
21 However, as in the first embodiment, once the operator  
22 has completed his spillage recovery task, he may wish  
23 to discharge the remainder of the contents held within  
24 either of the holding vessels of the apparatus. With  
25 reference to Fig 18, purge valve 160 is pressed  
26 momentarily so that it changes to position 2. This  
27 results in momentarily stopping the supply to venturi  
28 156 and the pilot signal to the venturi control valve  
29 180. At the same time positive pressure is sent via  
30 the transfer valve 162 to the first vessel 110 which  
31 was on its suction cycle. The first AND valve 184 will  
32 give an output signal forcing the transfer valve 162,  
33 the second OR valve 198 and the suction/discharge line  
34 control valve 182 to change over to position 2. The  
35 air supply on the suction/discharge line control valve  
36 182 is now changed over giving a valve close signal

1 (VCS) to valves 126 and 132 and a valve open signal  
2 (VOS) to valves 130 and 128.

3

4 At this stage the manual purge valve 160 will have been  
5 released and will have gone back to position 1.

6 Because the transfer valve 162 has also changed to  
7 position 2, vacuum has been transferred to the second  
8 vessel 112 as shown in Fig 19. Equally, the pressure  
9 discharge valve 190 has changed to position 2 due to  
10 the output pilot signal from the second OR valve 188.  
11 An air supply from the pressure discharge valve 190  
12 also passes through the transfer valve 160 and is used  
13 to pressurise the first vessel 110 causing the  
14 recovered fluid to be discharged into the discharge  
15 line 120 via valve 130. The discharging fluid also  
16 passes through the discharge line exit valve 192 which  
17 receives a valve open signal from the second OR valve  
18 188. Assuming that the operator does not place the  
19 suction head in any other spillage then no other fluids  
20 will be recovered.

21

22 A third embodiment of the invention will now be  
23 described with reference to Figs. 20 and 21 of the  
24 drawings. This embodiment is a preferred modification  
25 of the second embodiment but incorporates improvements  
26 and simplifications of the control arrangements.  
27 Features of the third embodiment common to or  
28 equivalent to features of the second embodiment are  
29 designated by like reference numerals prefixed "2"  
30 instead of "1".

31

32 The third embodiment employs upper and lower float  
33 valves 234, 236, 276 and 278 in each of the vessels 210  
34 and 212 as in the second embodiment. The various valves  
35 which control the operation of the apparatus differ in  
36 certain respects as follow:

- 1 (a) The inlet and outlet valves 226, 228, 230 and 232  
2 are of the spring-loaded, normally closed type. This  
3 eliminates spillage of fluid in transit, dispenses with  
4 the need for separate control lines and associated  
5 control valves to close the valves during the cyclic  
6 operation of the apparatus, and allows the exit line  
7 discharge valve 192 of the second embodiment to be  
8 dispensed with.
- 9 (b) The transfer valve 262 which switches the vacuum  
10 between the vessels is of the ball valve type with an  
11 actuator which minimises the changeover delay.
- 12 (c) The vessels each have a safety pressure release  
13 valve 300, 302; a pressure exhausting valve 304, 306  
14 for venting residual pressure following discharge of  
15 liquid from the respective vessel 210 or 212 and  
16 closure of the respective discharge valve 230 or 232;  
17 and a pressure discharge valve 308, 310, corresponding  
18 to the single pressure discharge valve 190 of the  
19 second embodiment, for pressurising the respective  
20 tanks to discharge liquid therefrom.
- 21 (d) The outputs of the float valves 234, 236, 276, 278  
22 are connected to control valves 312, 314 and 316. The  
23 uppermost valve 312 operates in response to the upper  
24 float valves 234, 236 and controls the ball valve 262  
25 to switch the vacuum between the vessels 210, 212. The  
26 lower control valves 314, 316 operate in response to  
27 the lower float valves 276, 278 of the vessels 210 and  
28 212 respectively during discharge of liquid. When the  
29 liquid in the relevant vessel falls below the float  
30 valve level, the corresponding control valve 314 or 316  
31 operates to allow the corresponding discharge valve 230  
32 or 232 to close and to cause the corresponding pressure  
33 exhaust valve 304 or 306 to open. Once open, the  
34 pressure exhaust valve 304 or 306 remains open until  
35 the vacuum is reapplied to the corresponding vessel 210  
36 or 212.

1 (e) The air supply 238 is connected to the apparatus  
2 via a main valve 318 which controls the main air supply  
3 to the venturi pump 256, via its integral control valve  
4 280, and which includes the manual purge valve (omitted  
5 from Fig. 21 for clarity) for manual discharge of  
6 liquid from the vessels. In this case, manual purging  
7 results in one vessel being purged prior to the other,  
8 as a result of the use of the ball valve 262 which  
9 always connects the venturi pump 256 to one or other of  
10 the vessels at any given time.

11

12 The apparatus of the third embodiment operates in a  
13 cyclic manner similar to the second embodiment, the  
14 transfer of the vacuum between the vessels being  
15 effected by the ball valve 262 and controlled by the  
16 operation of the upper and lower float valves in  
17 response to the liquid level rising and falling in the  
18 vessels as before.

19

20 Figs. 22 to 24 illustrate a suitable physical  
21 arrangement of the components of the apparatus. The  
22 illustrated example corresponds particularly to the  
23 third embodiment, however a similar general arrangement  
24 may be employed for the first and second embodiments.

25

26 The liquid holding vessels 210 and 212 have a generally  
27 upright cylindrical configuration and are disposed side  
28 by side, connected via conduits 242, 244 to the  
29 transfer valve 262, which has an associated actuator  
30 324. The venturi vacuum unit 256 is mounted to the rear  
31 of the transfer valve 262. The control panel 240 is  
32 mounted in front of the transfer valve 262, to one side  
33 of the apparatus. The vessel inlets 214, 216 extend  
34 outwardly from the front of the vessels 210, 212 and  
35 are connected to the common inlet conduit 218, in this  
36 example, via a filter 320. Whilst an inlet filter is

1 not strictly necessary in view of the absence of  
2 moving parts inside the vessels 210, 212, its use may  
3 be desirable in some circumstances or may be required  
4 by applicable technical standards.

5  
6 The safety pressure release valves 300, 302, pressure  
7 exhaust valves 304, 306 and pressure discharge valves  
8 308, 310 of Fig. 21 are omitted from Figs. 22 to 24 for  
9 clarity, but may suitably be mounted on three limbs of  
10 two respective cross pieces, one of which is mounted on  
11 each of the conduits 242 and 244 connecting the ball  
12 valve 262 to the respective vessels 210 and 212.

13  
14 Outlets 220, 222 extend outwardly from the front of the  
15 vessels 210, 212 below the inlets 214, 216, and are  
16 connected to the common discharge line 224.

17  
18 The apparatus may be mounted within a generally  
19 rectangular open frame 322.

20  
21 Whilst the invention has been described in relation to  
22 embodiments having two liquid holding vessels, it will  
23 be appreciated that the invention might also be applied  
24 to embodiments having more than two vessels, the  
25 control mechanisms being modified as appropriate.

26  
27 It will be further appreciated that the arrangement of  
28 upper and lower float valves in the second and third  
29 embodiments of the invention might also be  
30 advantageously applied to liquid recovery apparatus of  
31 the type having a single liquid holding vessel, as  
32 disclosed in EP-B-0 162 074, allowing the timer of such  
33 apparatus to be dispensed with and providing improved  
34 efficiency of operation.

35  
36 The advantages of the present invention and the ways in

1 which the disadvantages of previously known  
2 arrangements, as discussed in the introductory part of  
3 the present description, are overcome include the  
4 following:-

5  
6 The disadvantage of alternate vacuum and discharge is  
7 overcome by the fact that this invention operates a  
8 dual holding vessel system. When one vessel is full of  
9 recovered fluid, the vacuum is switched to the second  
10 vessel whilst the first one discharges. Therefore  
11 vacuum is never lost. This will be more convenient to  
12 the operator.

13  
14 The disadvantage of fluctuating (sinusoidal)  
15 vacuum/discharge is overcome by virtue of suction in  
16 the apparatus being created by a venturi ejector  
17 principle. This is the more favoured method by  
18 operators. It is also more reliable as there are no  
19 moving parts.

20  
21 The disadvantage of discharge pumps being damaged due  
22 to debris and suction line filters being removed is  
23 overcome by the fact that the apparatus has virtually  
24 no moving parts in contact with the recovered fluid.

25  
26 The disadvantage of high service down time is overcome  
27 due to the simplicity of the apparatus, its modern  
28 pneumatic control system, and the fact that it has  
29 virtually no moving parts.

30  
31 The disadvantage of a time giving too long a discharge  
32 time for low viscosity fluids and too short a discharge  
33 time for high viscosity fluids is overcome because the  
34 upper and lower float valves in each vessel which  
35 determine how long the pressurising discharge cycle  
36 should be.

1 That is, in its preferred form, the invention provides  
2 continuous vacuum in operation, venturi suction,  
3 minimal moving parts, low service downtime, no  
4 requirement for a suction filter, a simple control  
5 system, and a self-determining discharge cycle period.  
6 None of the existing types of liquid recovery apparatus  
7 discussed previously provide all of these features.  
8

1     Claims

2

3     1.   Apparatus for recovering liquids, comprising at  
4     least first and second vessels for liquid, vacuum pump  
5     means for applying a vacuum selectively to the first  
6     and second vessels, each vessel having an inlet for  
7     recovered liquid which includes valve means restricting  
8     liquid exit from the vessel, and an outlet through  
9     which liquid is discharged from the vessel, the outlet  
10    including valve means which restricts liquid entry to  
11    the vessel, and a conduit connected to said inlets to  
12    convey recovered liquid to the vessels.

13

14    2.   Apparatus as claimed in Claim 1, further including  
15    control means including switching means adapted to  
16    switch the applied vacuum from one vessel to the other  
17    in response to a control signal indicating that the  
18    liquid level in said one container has reached a  
19    predetermined maximum level and to cause the liquid  
20    collected in said one container to be discharged via  
21    said outlet of said one vessel.

22

23    3.   Apparatus as claimed in Claim 2, wherein said  
24    control means is adapted to apply said vacuum is  
25    alternately to said first and second vessels in a  
26    cyclical manner such that recovered liquid is drawn  
27    into one of the vessels via its inlet whilst any  
28    previously recovered liquid is discharged from the  
29    other vessel via its outlet, the vacuum being switched  
30    from said one vessel to said other vessel when the  
31    recovered liquid in said one vessel rises to said  
32    predetermined level, such that recovered liquid is  
33    drawn into said other vessel whilst the previously  
34    recovered liquid is discharged from said one vessel.

35

36    4.   Apparatus as claimed in Claim 2 or Claim 3 wherein

1 said control means comprises pneumatic control means.

2

3 5. Apparatus as claimed in Claim 2, wherein said  
4 control signal is generated by first liquid level  
5 sensors located in each of said vessels.

6

7 6. Apparatus as claimed in Claim 2, wherein said  
8 sensors comprise float valves.

9

10 7. Apparatus as claimed in any preceding Claim,  
11 wherein said vacuum pump comprises a venturi ejector  
12 type pump.

13

14 8. Apparatus as claimed in any preceding Claim,  
15 wherein the valve means of said inlets and outlets  
16 comprise on way check valves.

17

18 9. Apparatus as claimed in any one of Claims 1 to 6,  
19 wherein the valve means of said inlets and outlets  
20 comprise pneumatically actuated valves.

21

22 10. Apparatus as claimed in Claim 8 wherein said  
23 pneumatically actuated valves are normally closed  
24 valves.

25

26 11. Apparatus as claimed in Claim 2 or Claim 3,  
27 wherein the period during which liquid is discharged  
28 from said one vessel is determined by timer means.

29

30 12. Apparatus as claimed in Claim 3, wherein said  
31 control means is further adapted to cause a pressure to  
32 be applied alternately to the interiors of said first  
33 and second vessels when recovered liquid is to be  
34 discharged therefrom.

35

36 13. Apparatus as claimed in Claim 12, wherein said

1 control means is further adapted to cause said pressure  
2 to be applied to the interior of said one vessel when  
3 the liquid level in said one vessel reaches said first  
4 level.

5

6 14. Apparatus as claimed in Claim 2 or Claim 3  
7 wherein, said control means is further adapted to cause  
8 said inlet valve means of said one vessel to close,  
9 said outlet valve means of said one vessel to open,  
10 said inlet valve means of said other vessel to open and  
11 said outlet valve means of said other vessel to close  
12 when the liquid level in said one vessel reaches said  
13 first level.

14

15 15. Apparatus as claimed in Claim 5 wherein said first  
16 and second vessels each includes second level detector  
17 means for detecting when the level of recovered liquid  
18 in the vessel falls below a second, lower,  
19 predetermined level.

20

21 16. Apparatus as claimed in Claim 15 wherein said  
22 control means is further adapted to apply a pressure to  
23 the interior of said one vessel while liquid is being  
24 discharged therefrom and to remove said applied  
25 pressure from said one vessel when the liquid level in  
26 said one vessel falls below said second level.

27

28 17. Apparatus as claimed in any preceding Claim,  
29 wherein said outlets of said first and second vessels  
30 are connected to a common discharge conduit, said  
31 discharge conduit including discharge valve means.

32

33 18. Apparatus as claimed in Claim 17, wherein said  
34 control means is further adapted to cause said  
35 discharge valve means to close when the liquid level in  
36 said one vessel falls below a lowermost predetermined

1 level and to open when the liquid level in said other  
2 vessel exceeds an uppermost predetermined level.

3

4 19. Apparatus as claimed in Claim 3, further including  
5 counter means adapted to be incremented at a  
6 predetermined point in the cyclical operation of the  
7 apparatus.

8

9 20. Apparatus as claimed in Claim 19, wherein said  
10 counter means is incremented when the vacuum is  
11 switched from one of said first and second vessels to  
12 the other.

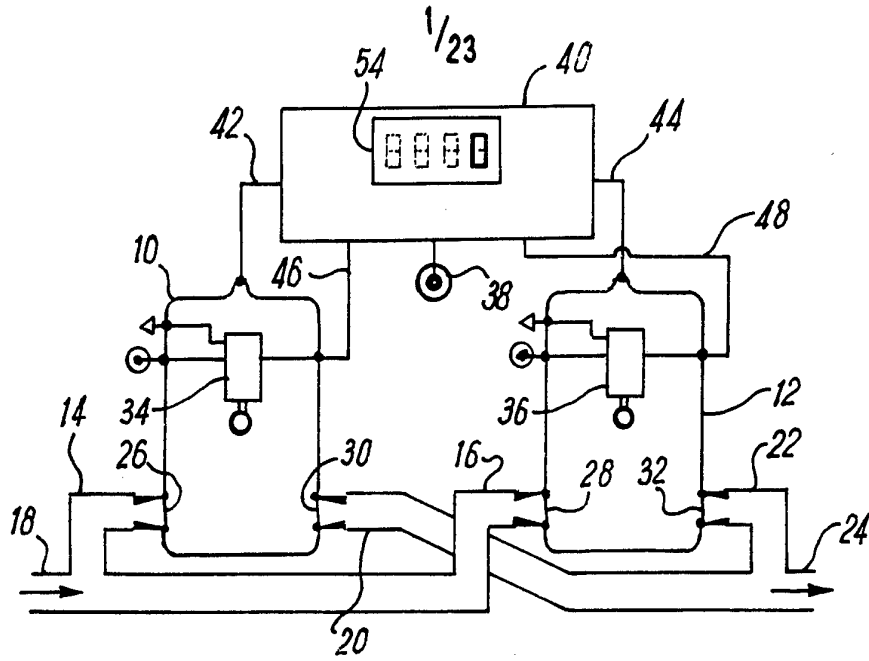
13

14 21. Apparatus as claimed in any preceding Claim,  
15 further including manually operable control means  
16 whereby recovered liquid may be discharged from said  
17 first and/or second vessels.

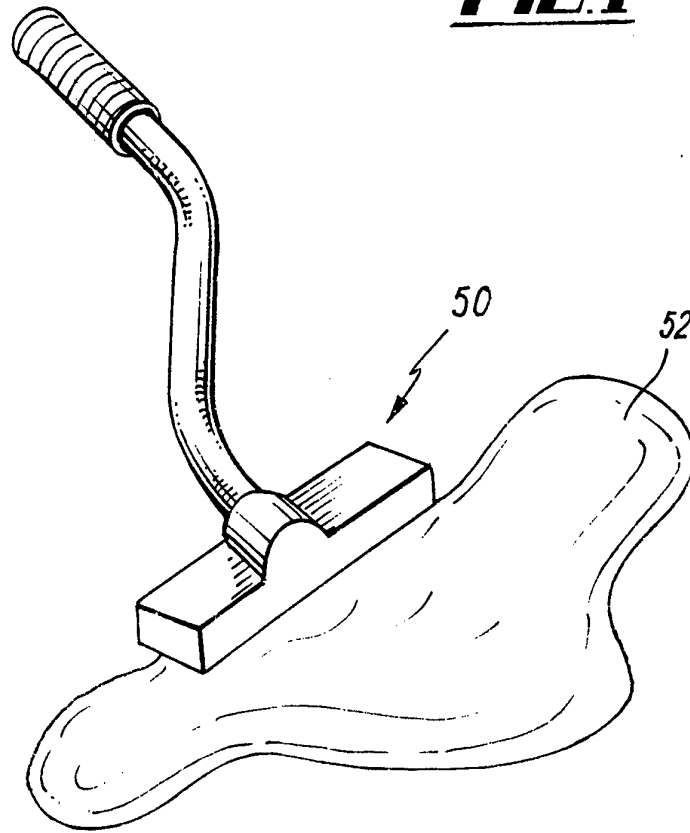
18

19 22. Apparatus for recovering liquids, comprising at  
20 least a first vessel for liquid, vacuum pump means for  
21 applying a vacuum selectively to said at least one  
22 vessel, said at least one vessel having an inlet for  
23 recovered liquid which includes valve means restricting  
24 liquid exit from the vessel, and an outlet through  
25 which liquid is discharged from the vessel, the outlet  
26 including valve means which restricts liquid entry to  
27 the vessel, and a conduit connected to said inlets to  
28 convey recovered liquid to the vessel, and further  
29 including first liquid level detecting means for  
30 detecting when the liquid level in said at least one  
31 vessel reaches an uppermost predetermined level and  
32 second liquid level detecting means for detecting when  
33 the liquid level in said at least one vessel reaches a  
34 lowermost predetermined level, and control means  
35 responsive to said first and second level detecting  
36 means and adapted to remove said vacuum from said at

1    least one vessel and to cause liquid contained therein  
2    to be discharged from said vessel when said liquid  
3    level reaches said uppermost predetermined level and to  
4    cause said vacuum to be reapplied to said vessel when  
5    said liquid level falls to said lowermost predetermined  
6    level.  
7

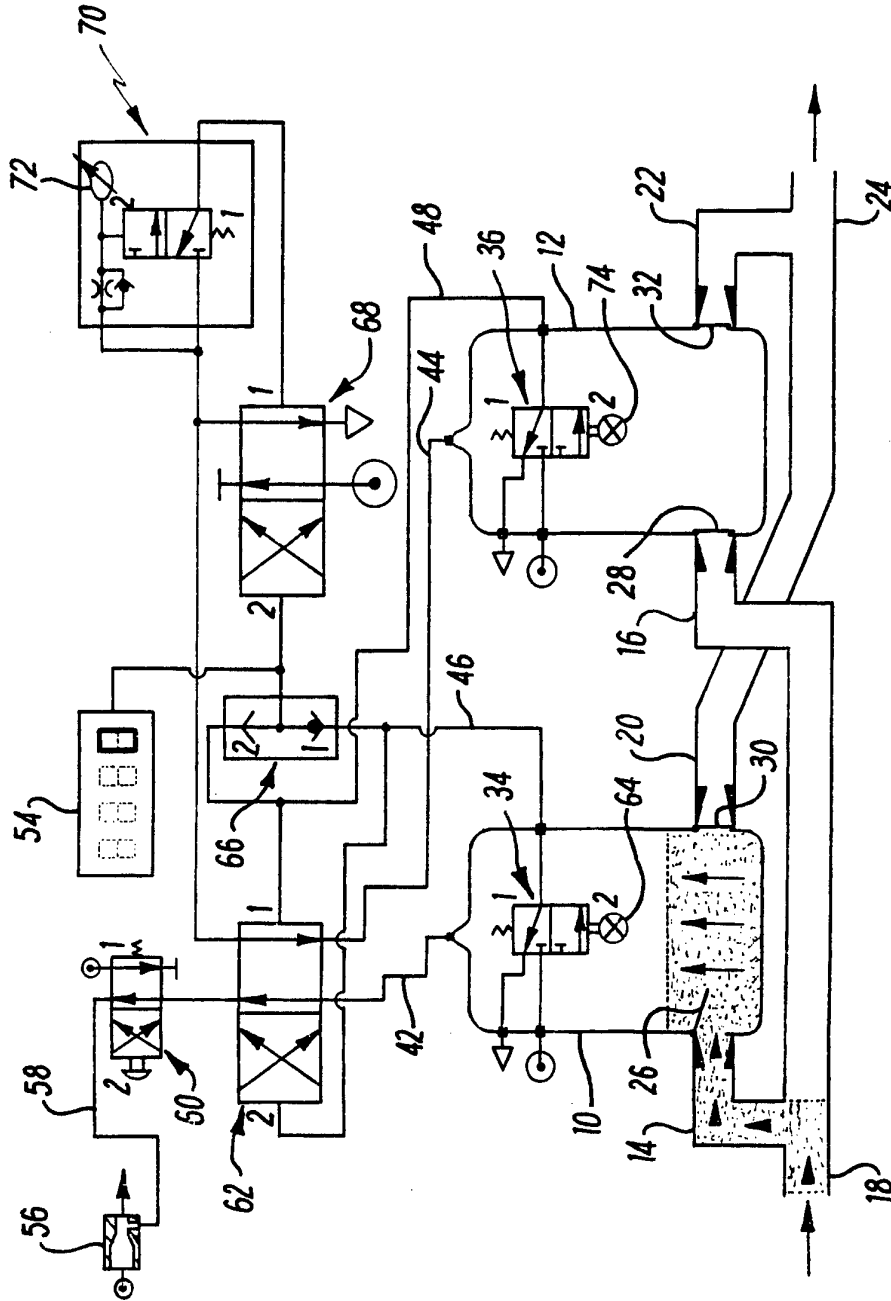


**FIG. 1**



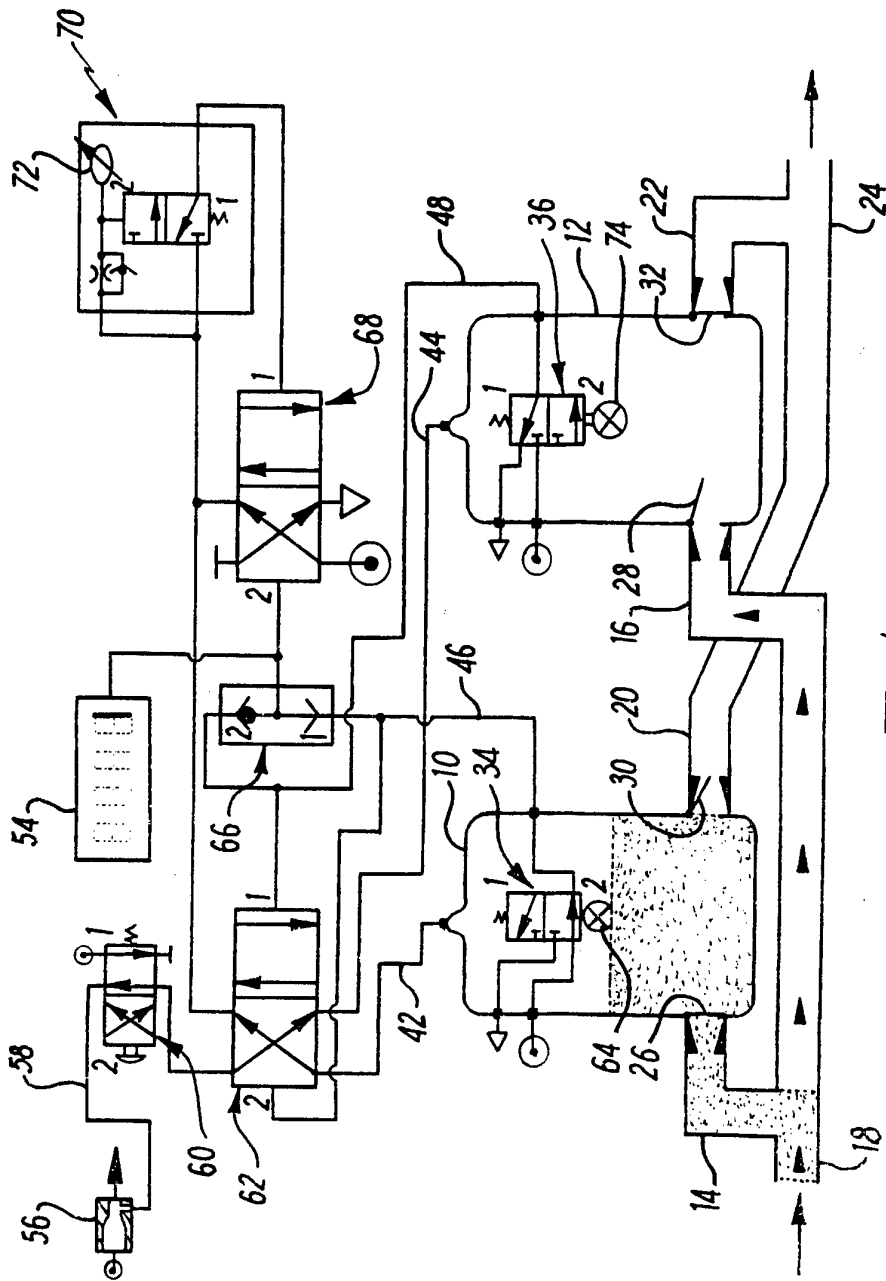
**FIG. 2**

2/23



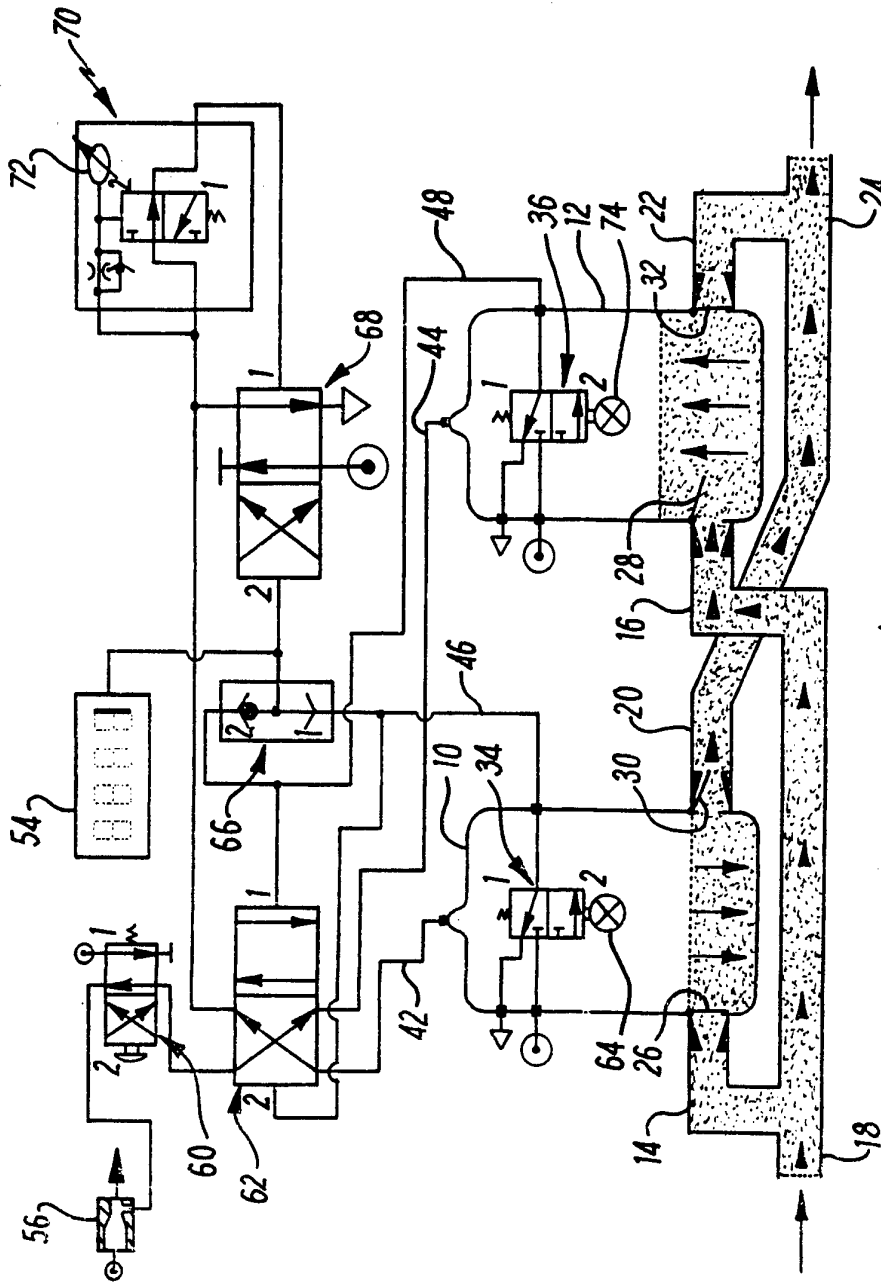
**Fig. 3**

3/23



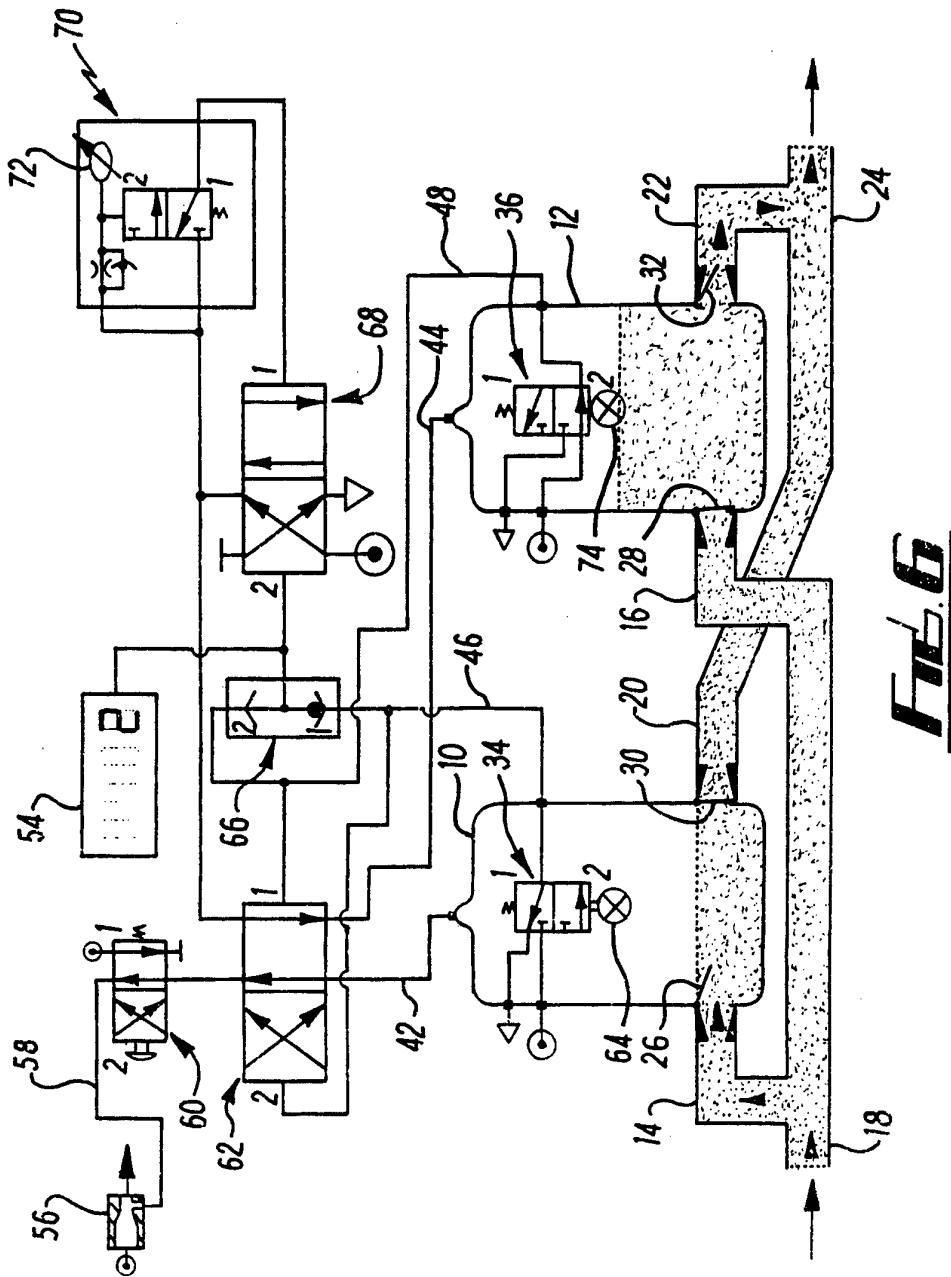
**FIG. 4**

4/23



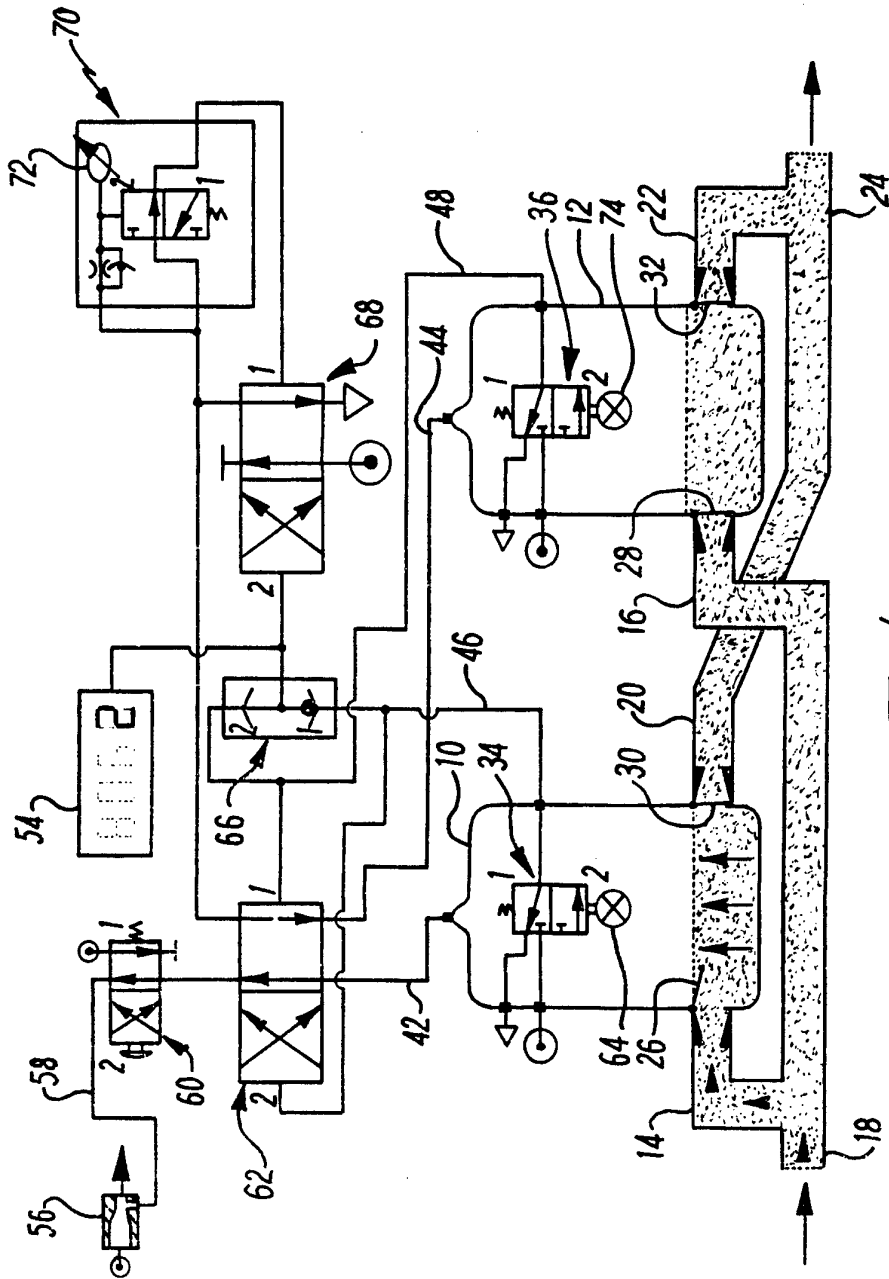
**FIG. 5**

5/23



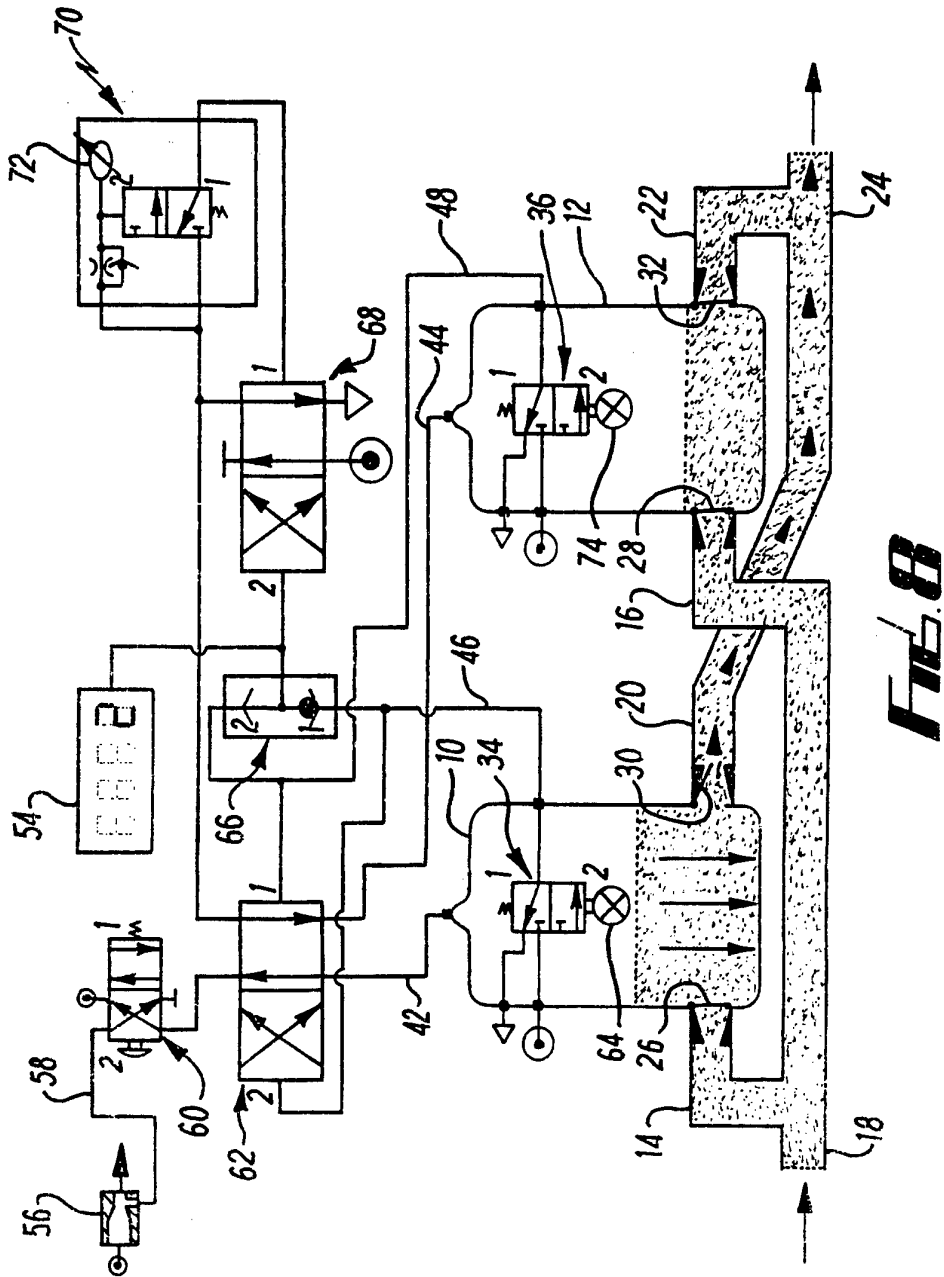
**FIG. 6**

6/23



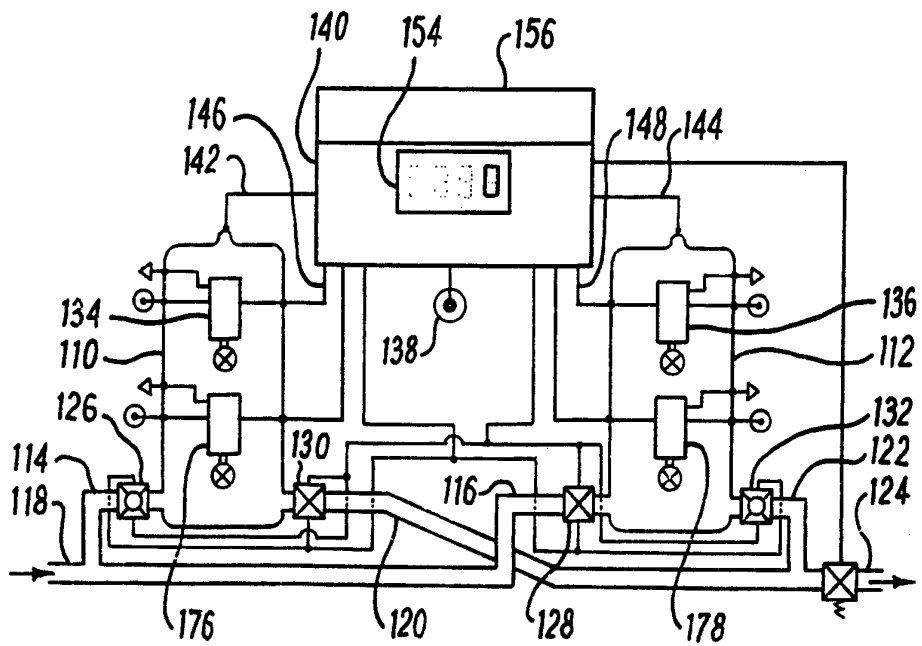
**FIG 7**

7/23



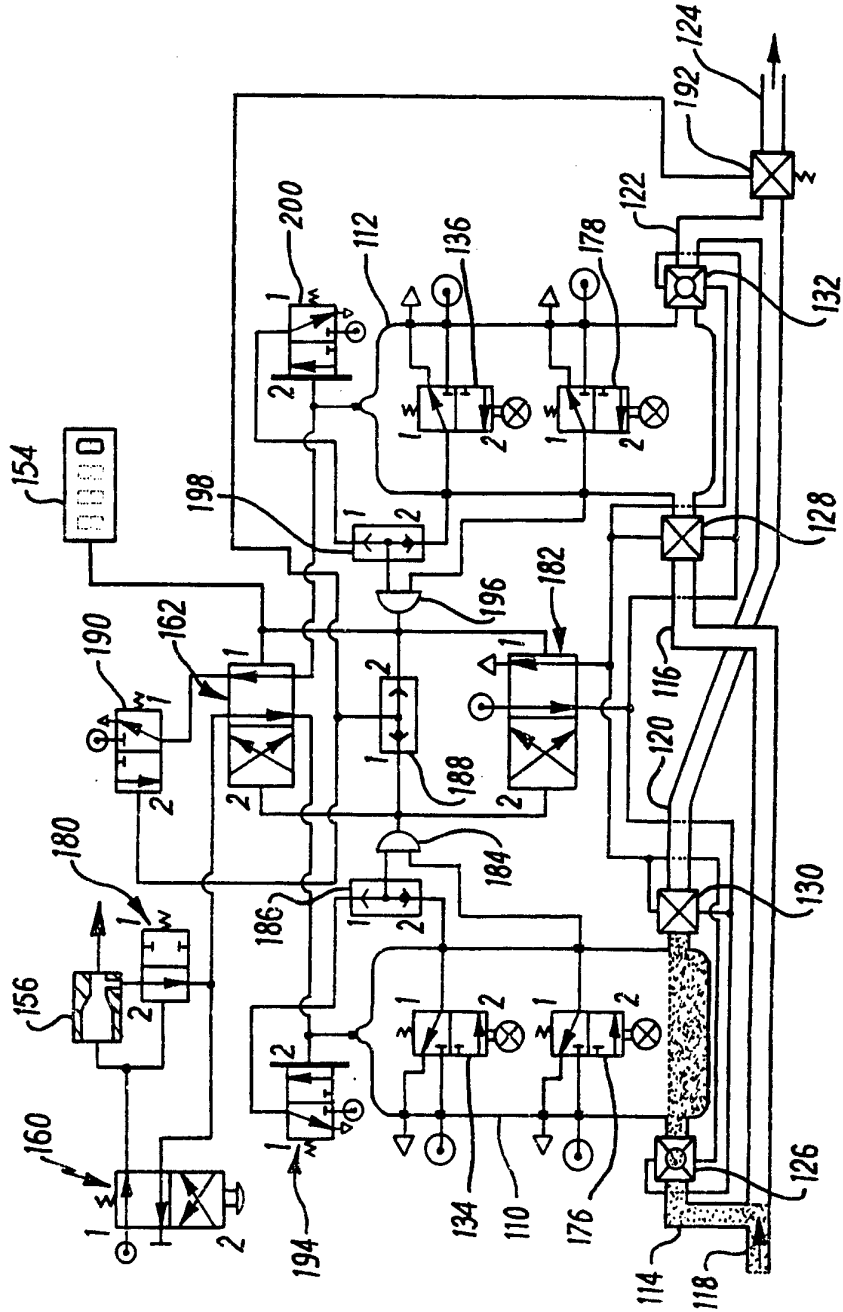
**FIG. 8**

8/23



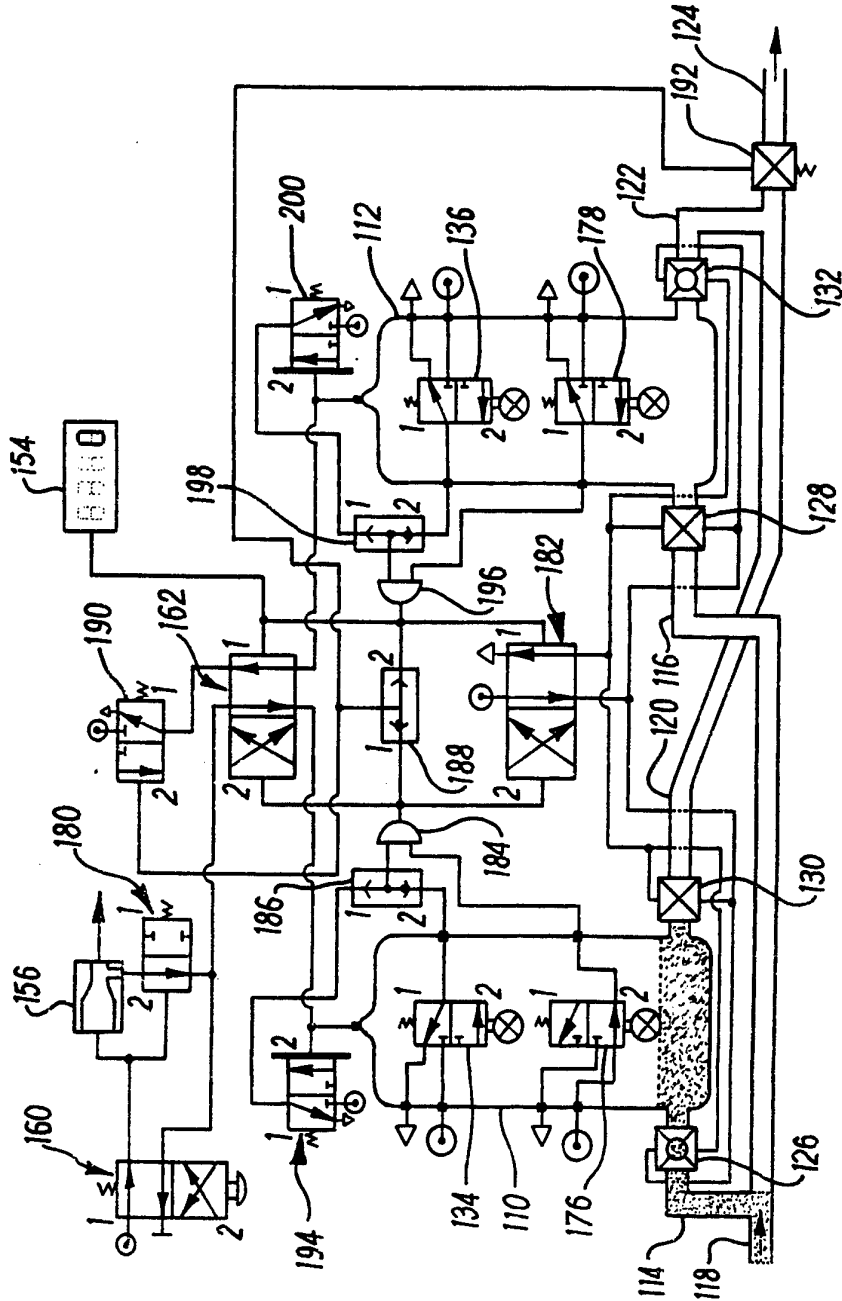
**FIG. 9**

9/23



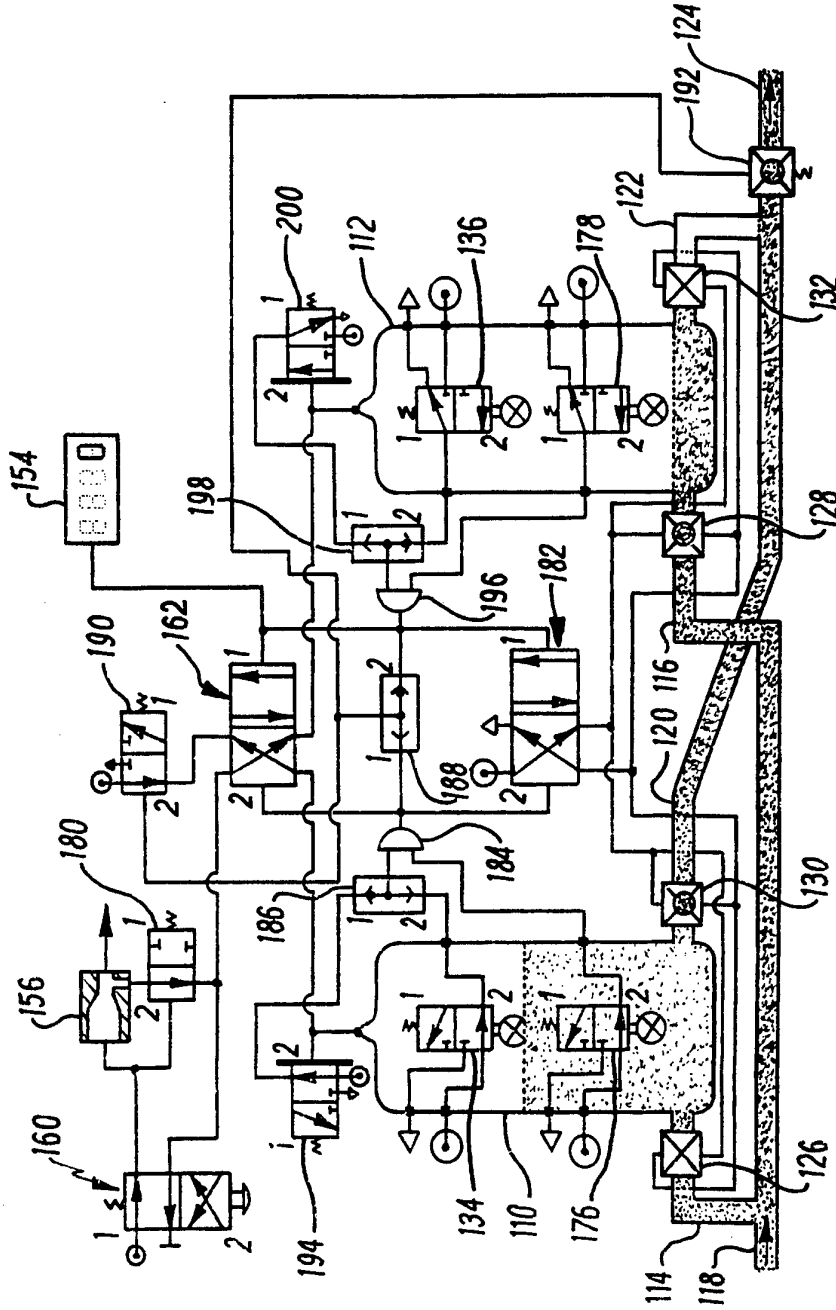
**FIG 10**

10/23



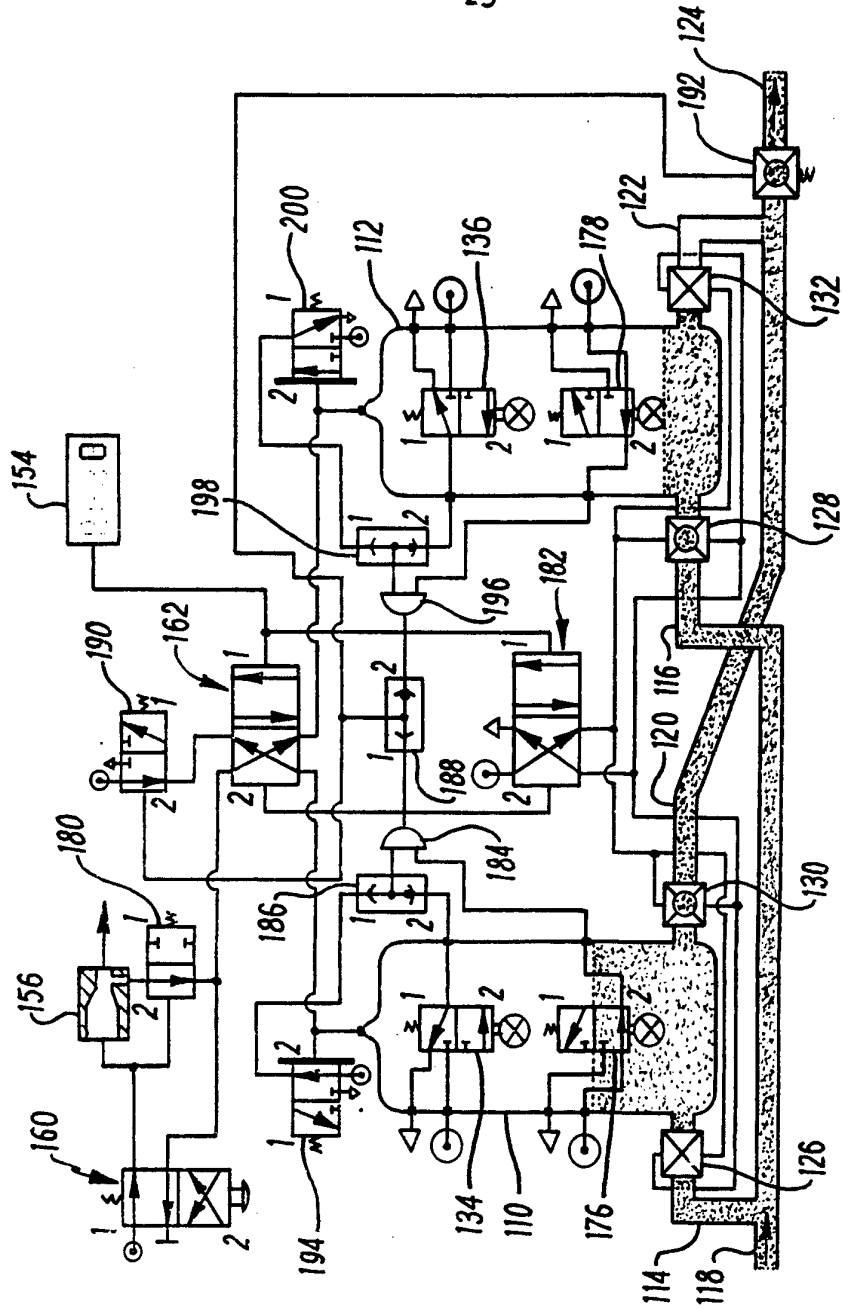
**FIG. 11**

11/23



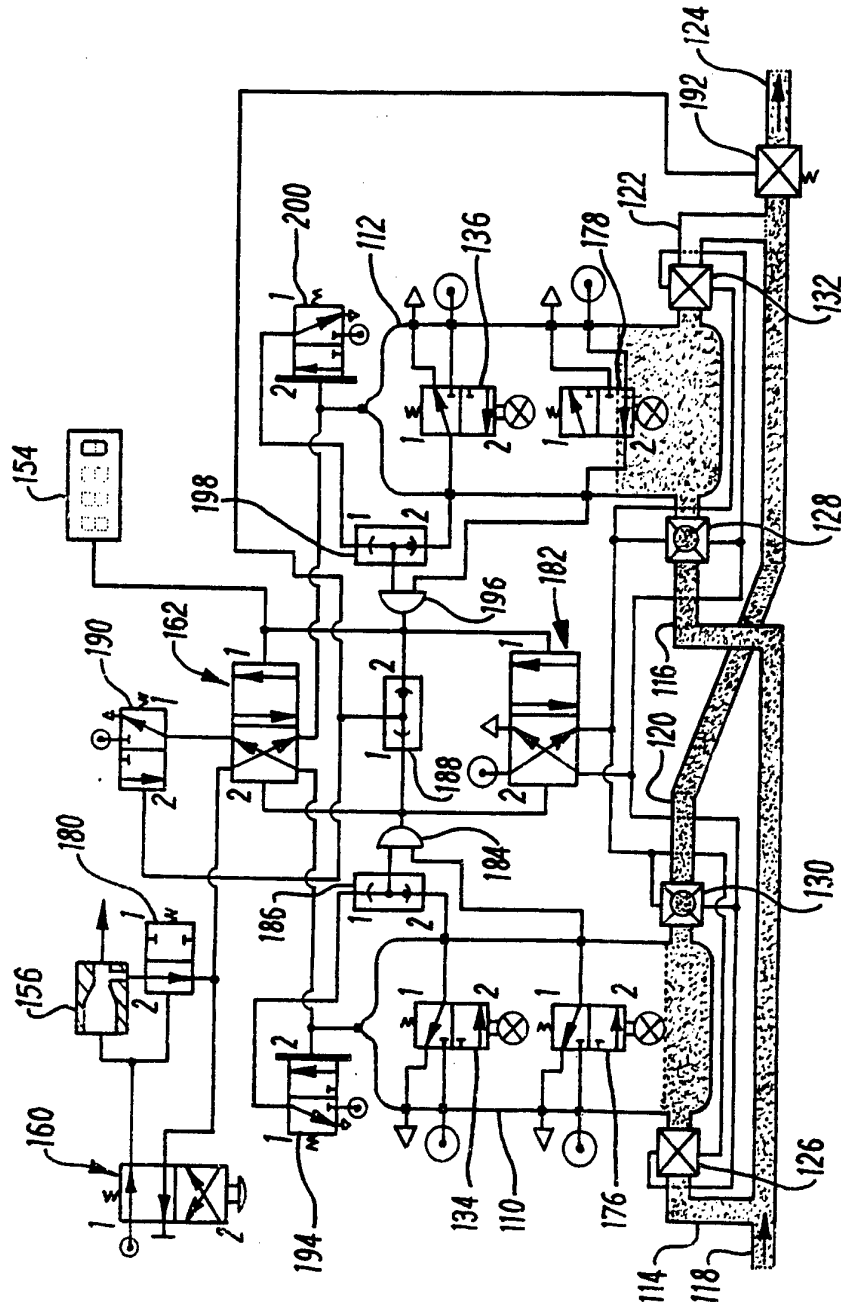
**FIG. 12**

12/23



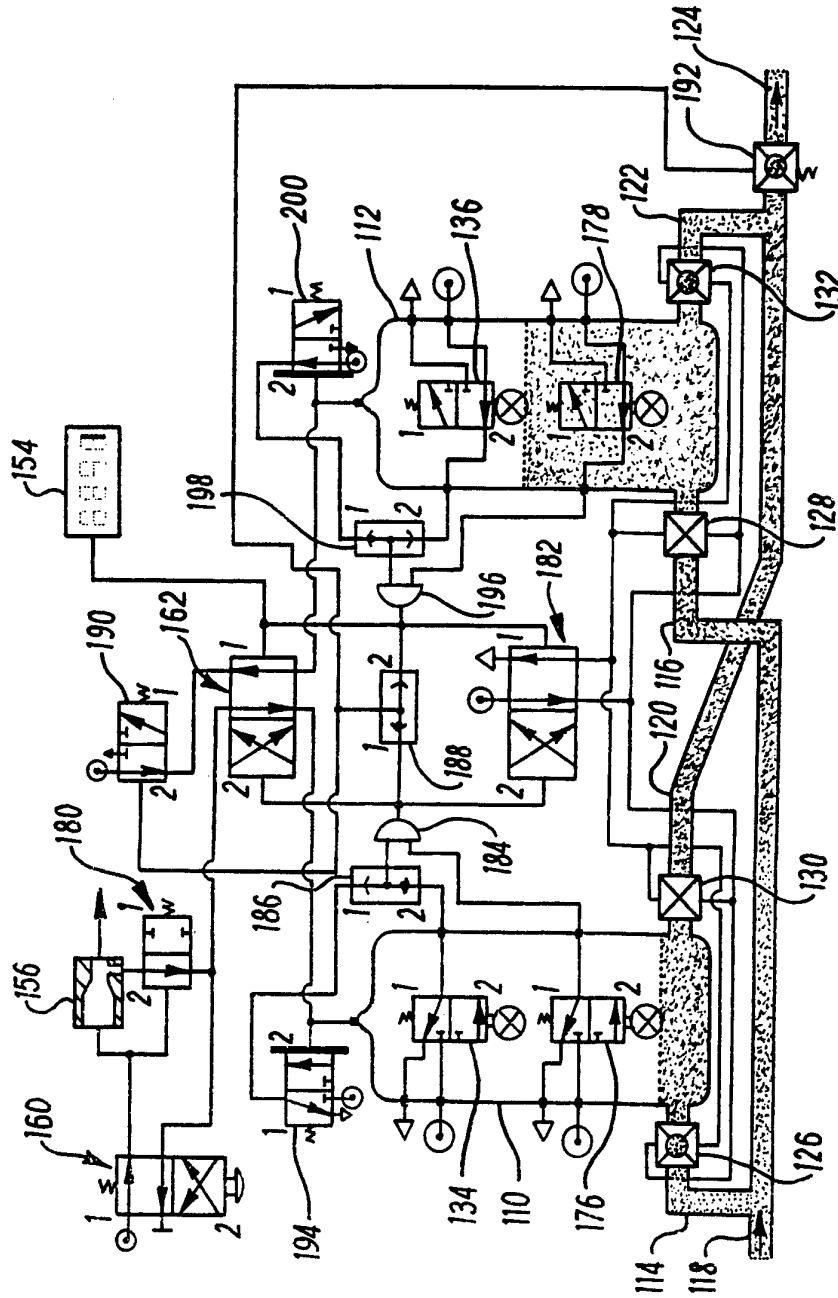
**FIG. 13**

13/23



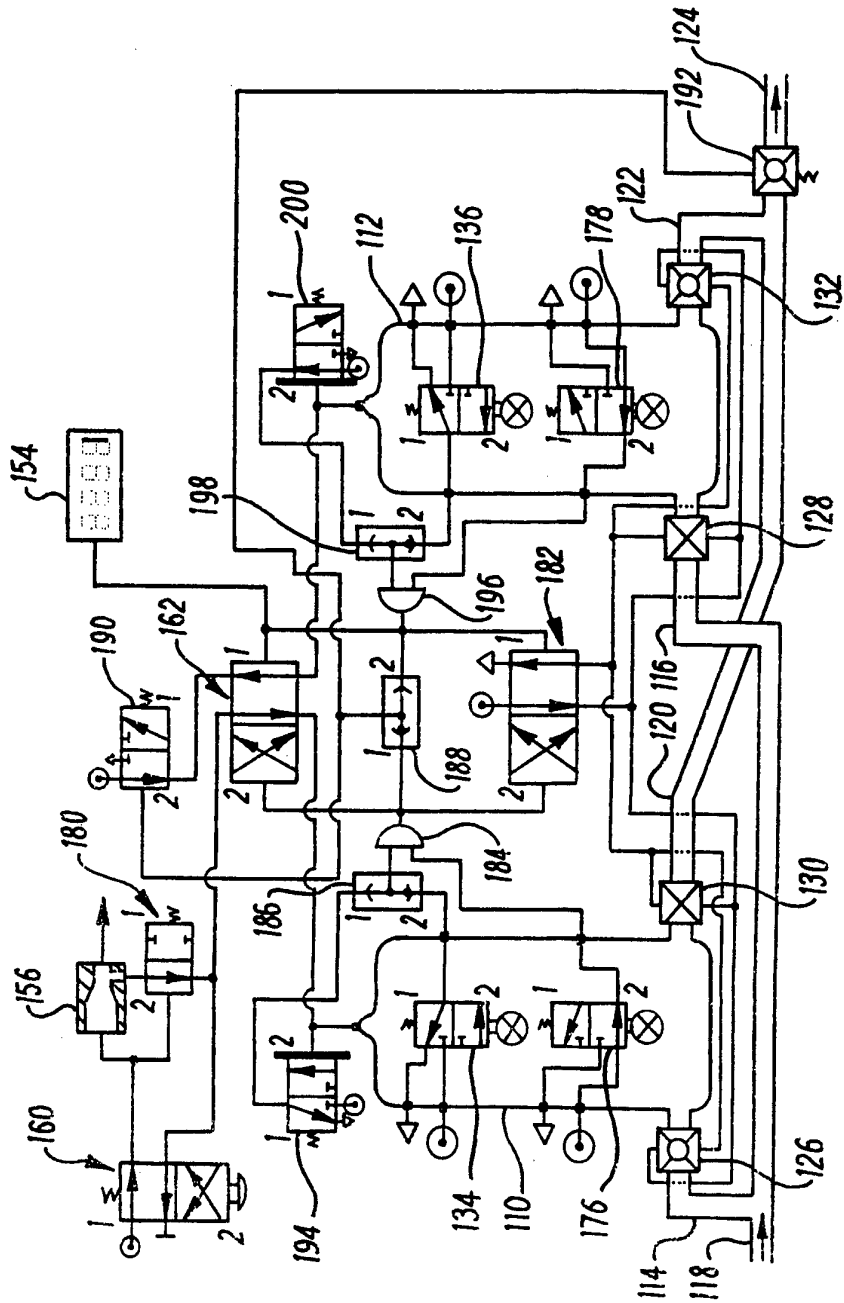
**FIG 14**

14/23



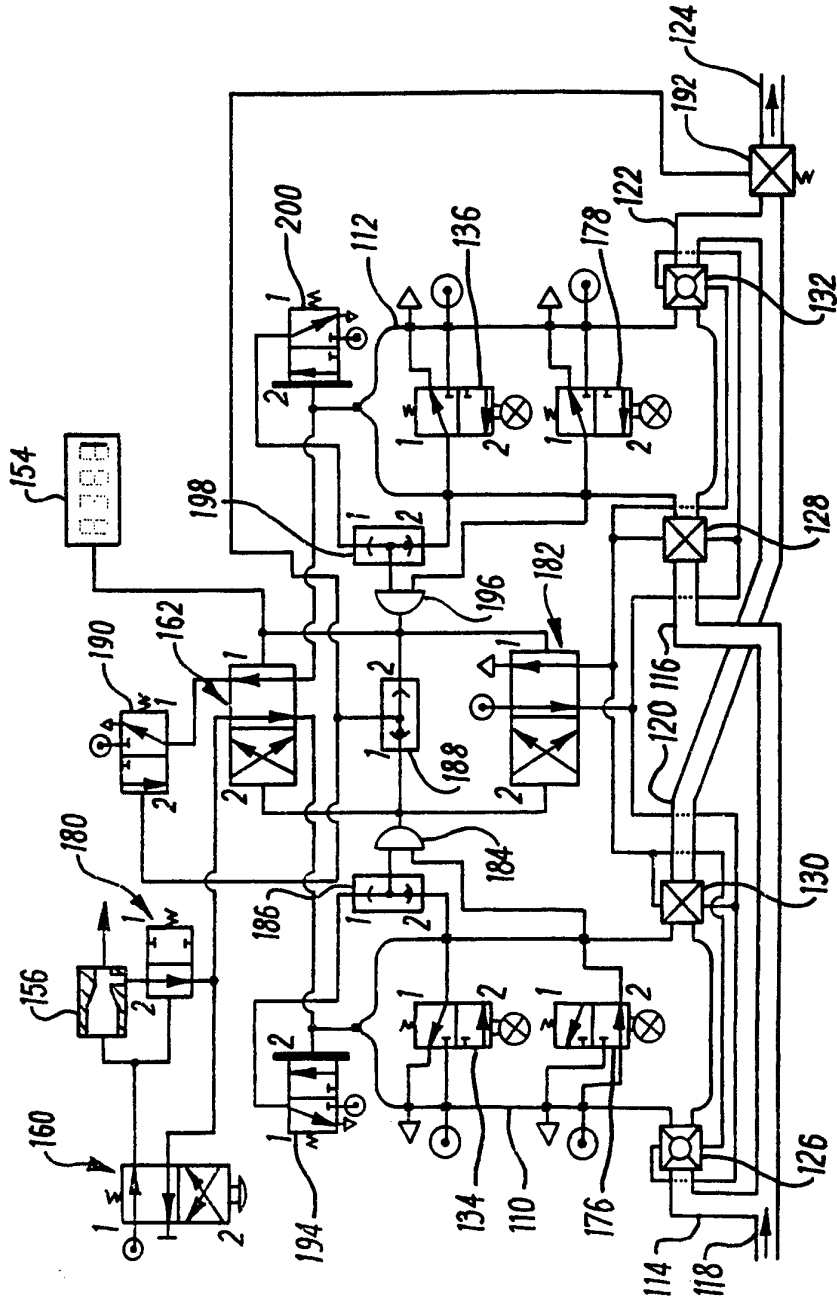
**FIG. 15**

15/23



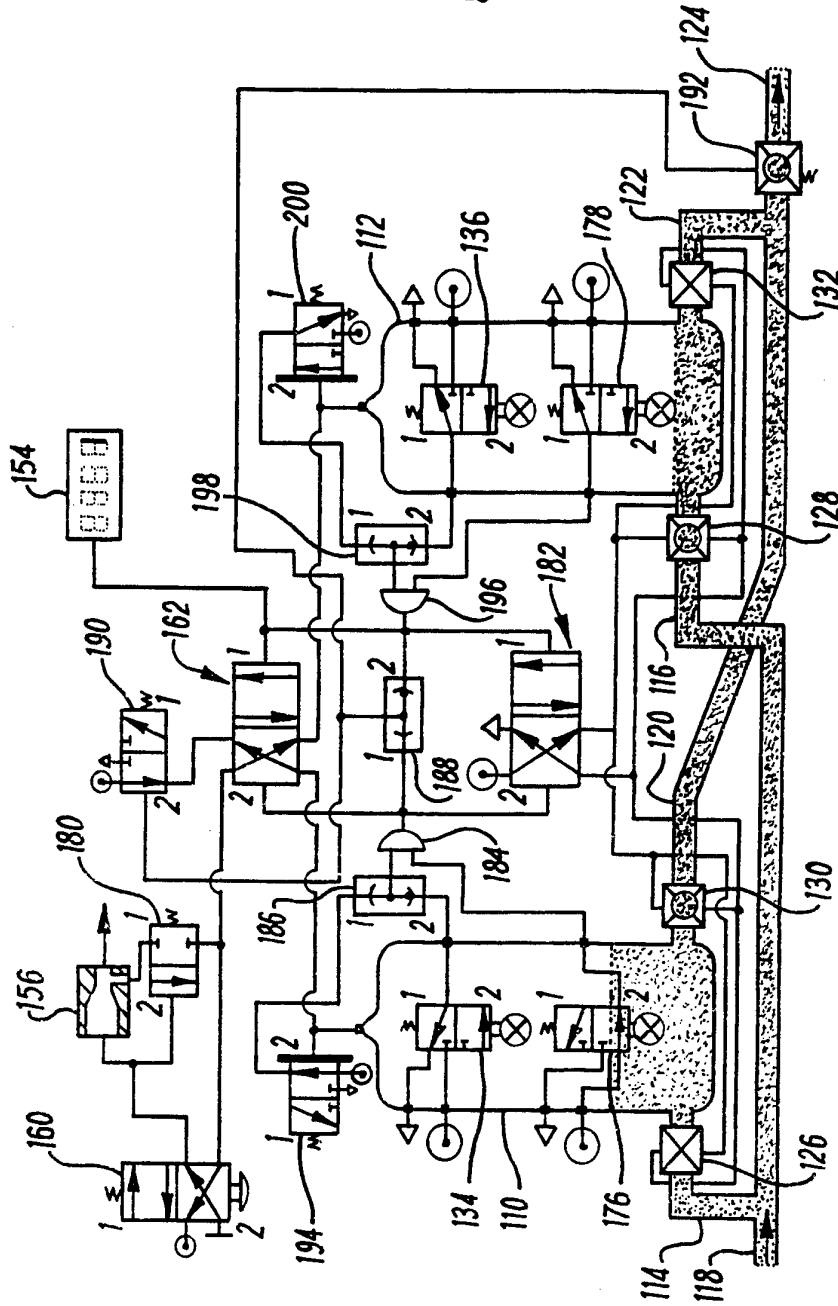
**FIG. 16**

16/23



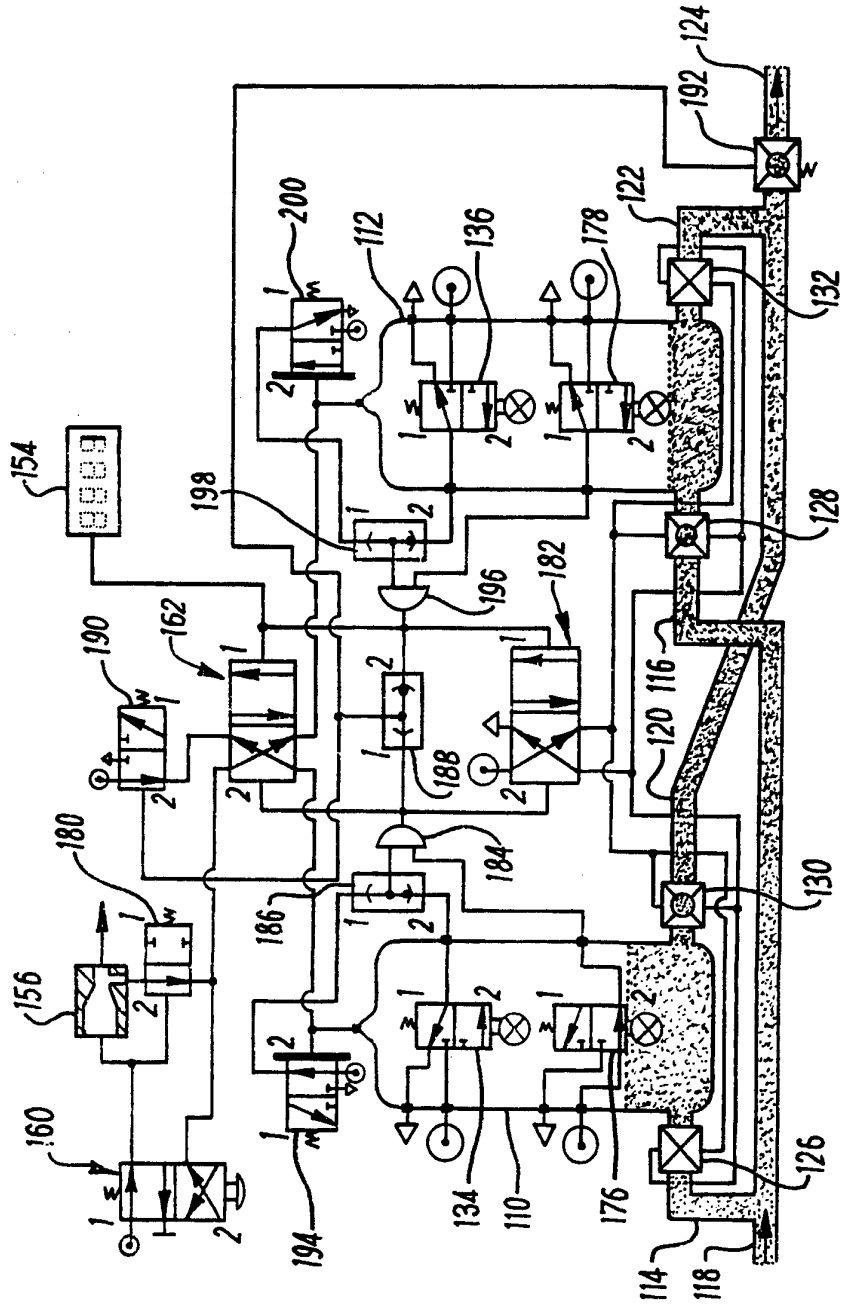
**FILE 17**

17/23



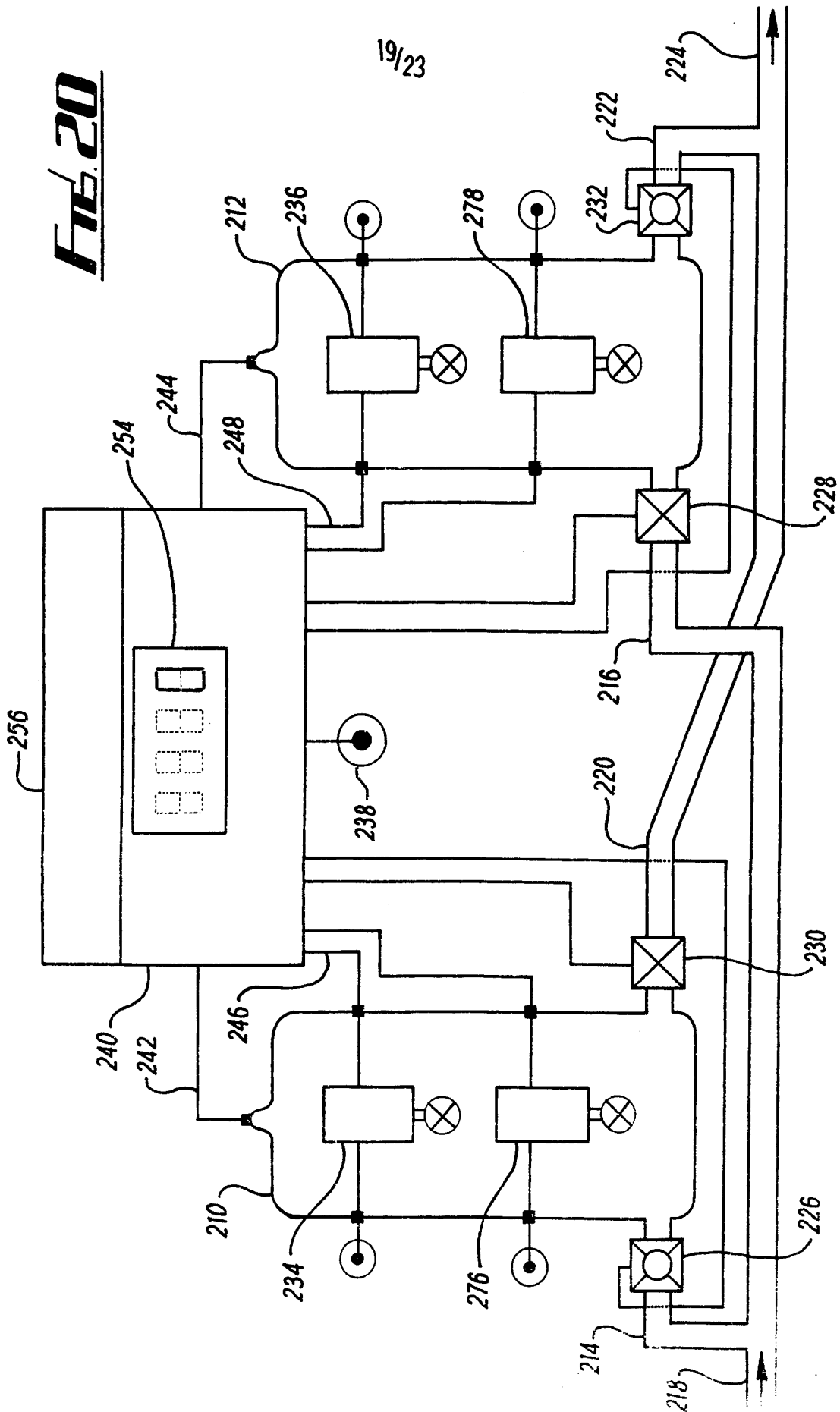
**FILE 18**

18/23

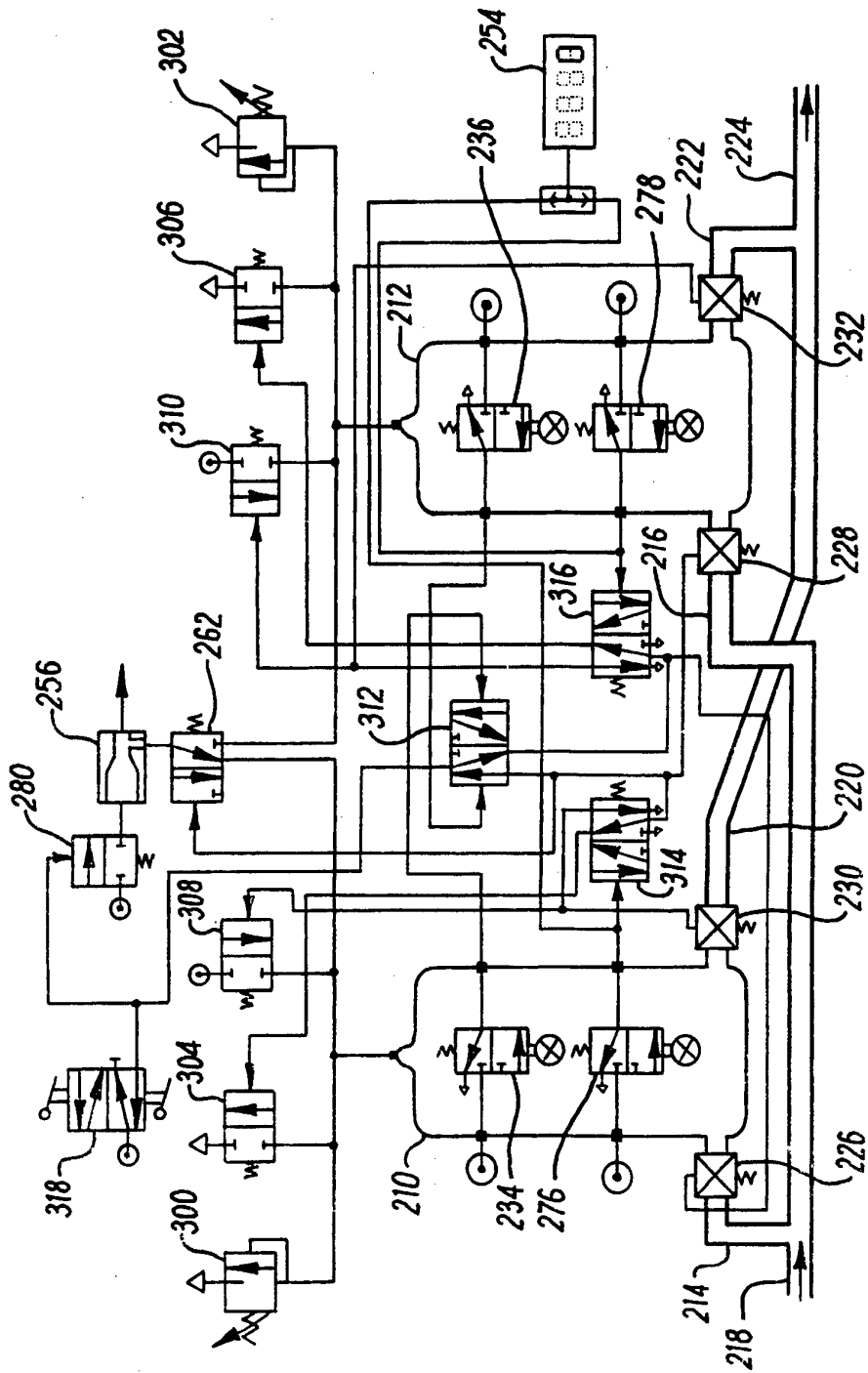


**FIG 19**

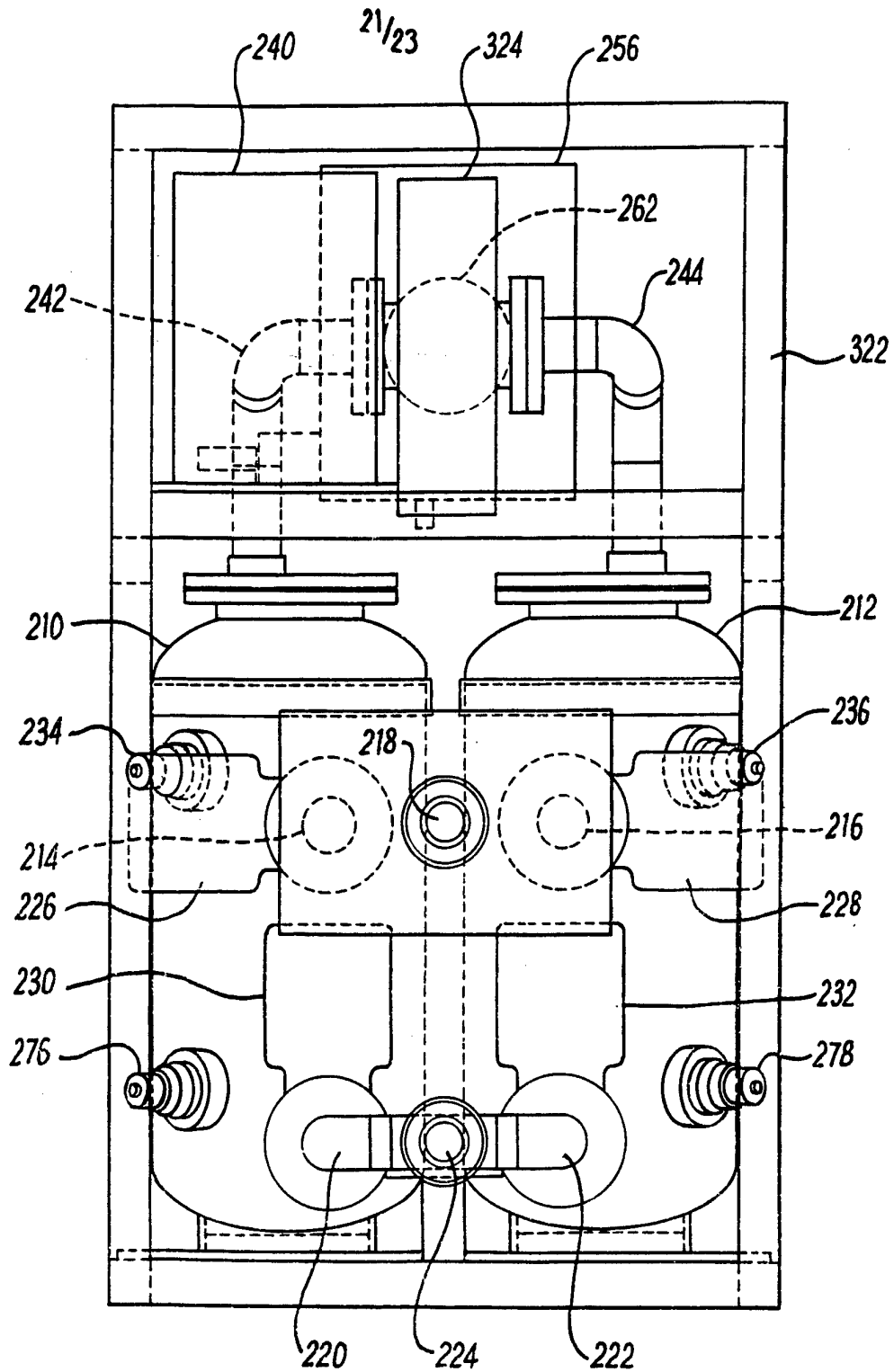
**FIG. 20**



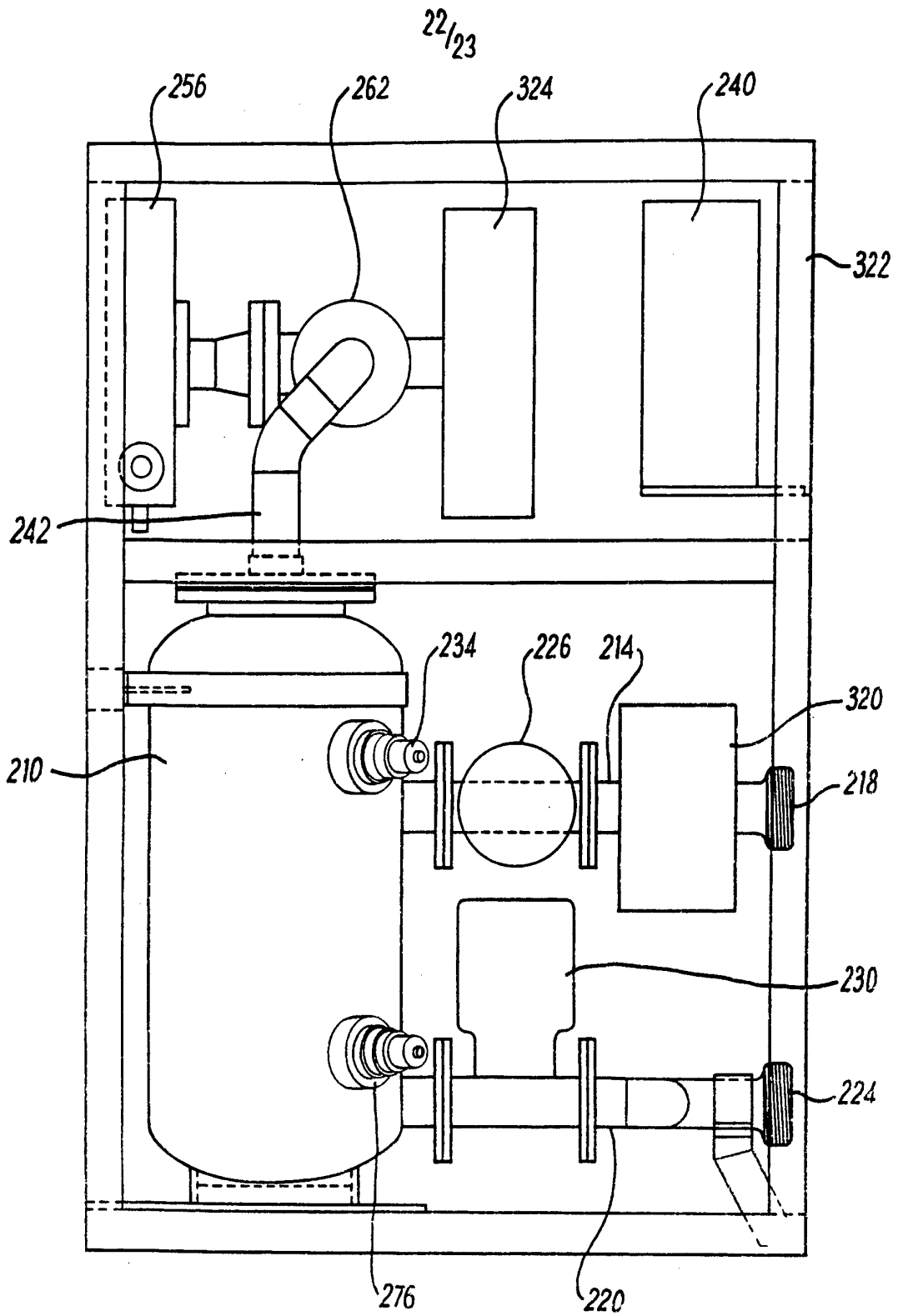
20/23



**FIG. 21**

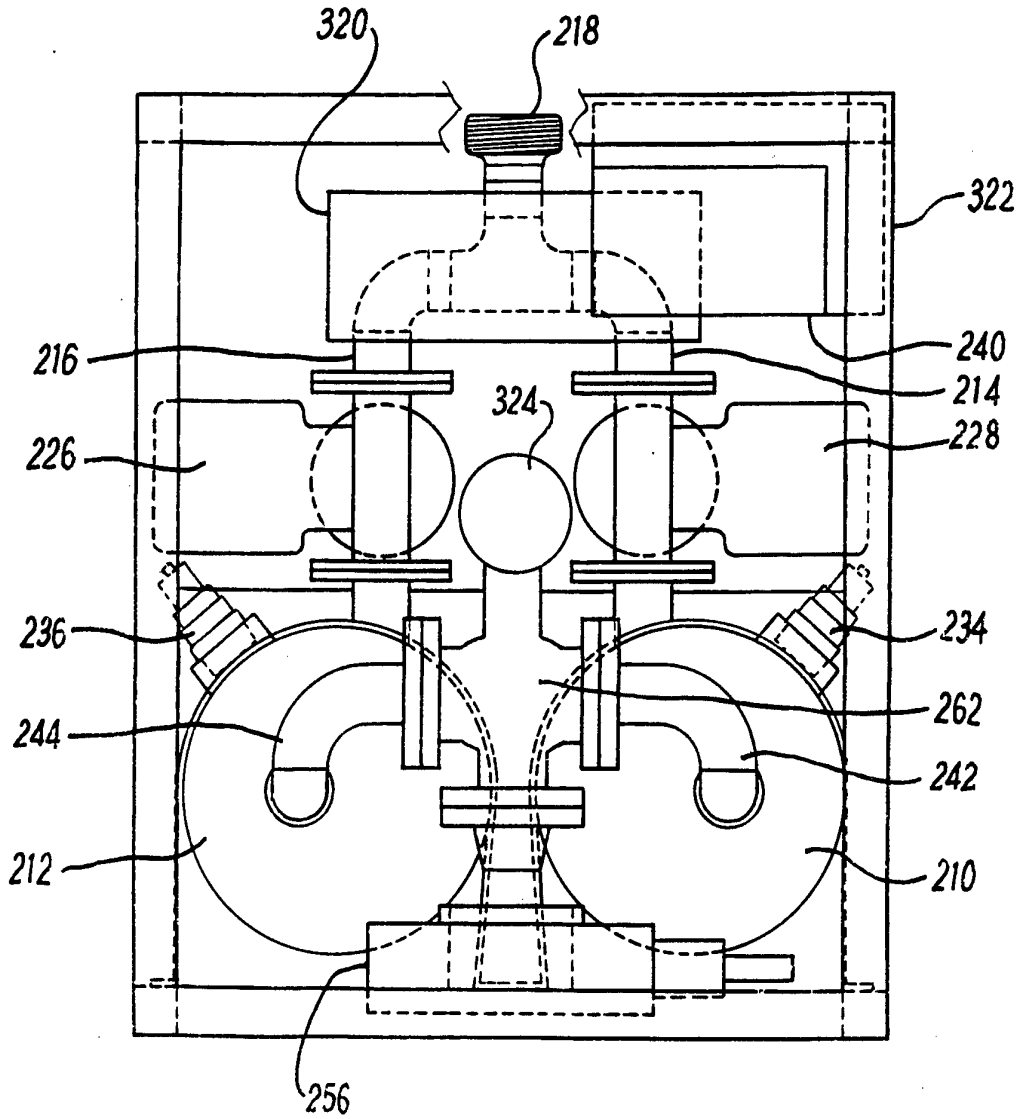


**FIG. 22**



**FIG. 23**

23/23



**FIG. 24**

# INTERNATIONAL SEARCH REPORT

Inter. Application No  
PCT/GB 95/00013

<b>A. CLASSIFICATION OF SUBJECT MATTER</b> IPC 6 B08B5/04 A47L5/38 A47L7/00 F04F5/20 F04F5/54 E21B21/00 B24C3/06		
According to International Patent Classification (IPC) or to both national classification and IPC		
<b>B. FIELDS SEARCHED</b>		
Minimum documentation searched (classification system followed by classification symbols) IPC 6 B08B A47L F04F E21B F04B B24C		
Documentation searched other than minimum documentation to the extent that such documents are included in the fields searched		
Electronic data base consulted during the international search (name of data base and, where practical, search terms used)		
<b>C. DOCUMENTS CONSIDERED TO BE RELEVANT</b>		
Category *	Citation of document, with indication, where appropriate, of the relevant passages	Relevant to claim No.
A	WO,A,85 02356 (ABERLAN EQUIPMENT & SERVICE CO LTD) 6 June 1985 cited in the application see abstract ---	1,6,9,11
A	DE,A,42 09 439 (KSR KÜHL-SYSTEM-RECYCLING GMBH & CO) 30 September 1993  see abstract see column 5, line 5 - line 32 see column 6, line 24 - line 55; figure 1 ---	1-5,14, 15,17, 18,22
A	US,A,2 597 434 (L.H. BISHOP ET AL) 20 May 1952 see column 1, line 29 - column 2, line 11 see column 3, line 34 - column 4, line 6 see column 4, line 61 - column 5, line 28 see column 6, line 47 - column 7, line 35 --- -/--	1-4, 9-14,19
<input checked="" type="checkbox"/> Further documents are listed in the continuation of box C. <span style="margin-left: 200px;"><input checked="" type="checkbox"/> Patent family members are listed in annex.</span>		
* Special categories of cited documents :		
"A" document defining the general state of the art which is not considered to be of particular relevance "E" earlier document but published on or after the international filing date "L" document which may throw doubts on priority claim(s) or which is cited to establish the publication date of another citation or other special reason (as specified) "O" document referring to an oral disclosure, use, exhibition or other means "P" document published prior to the international filing date but later than the priority date claimed	"T" later document published after the international filing date or priority date and not in conflict with the application but cited to understand the principle or theory underlying the invention "X" document of particular relevance; the claimed invention cannot be considered novel or cannot be considered to involve an inventive step when the document is taken alone "Y" document of particular relevance; the claimed invention cannot be considered to involve an inventive step when the document is combined with one or more other such documents, such combination being obvious to a person skilled in the art. "&" document member of the same patent family	
Date of the actual completion of the international search  <p style="text-align: center; font-size: 1.2em;">10 April 1995</p>	Date of mailing of the international search report  <p style="text-align: center; font-size: 1.2em;">28.04.95</p>	
Name and mailing address of the ISA European Patent Office, P.B. 5818 Patentlaan 2 NL - 2280 HV Rijswijk Tel. (+31-70) 340-2040, Tx. 31 651 epo nl, Fax: (+31-70) 340-3016	Authorized officer  <p style="text-align: center; font-size: 1.2em;">Lilimpakis, E</p>	

## INTERNATIONAL SEARCH REPORT

Inter national Application No  
PCT/GB 95/00013

C.(Continuation) DOCUMENTS CONSIDERED TO BE RELEVANT		
Category *	Citation of document, with indication, where appropriate, of the relevant passages	Relevant to claim No.
A	US,A,4 976 758 (R.C.K. YEN) 11 December 1990 see abstract see column 6, line 12 - line 18 ---	1
A	EP,A,0 332 090 (H. KAUFFELDT ET AL) 13 September 1989 see abstract see column 1, line 15 - line 22 see column 7, line 55 - column 9, line 9 -----	1

1

# INTERNATIONAL SEARCH REPORT

Information on patent family members

Inter:   nal Application No <b>PCT/GB 95/00013</b>
---

Patent document cited in search report	Publication date	Patent family member(s)	Publication date
WO-A-8502356	06-06-85	EP-A, B 0162074 US-A- 4691407	27-11-85 08-09-87
-----			
DE-A-4209439	30-09-93	NONE	
-----			
US-A-2597434	20-05-52	NONE	
-----			
US-A-4976758	11-12-90	US-A- 5034031	23-07-91
-----			
EP-A-0332090	13-09-89	DE-A- 3808124 AT-T- 114228 DE-D- 58908651 US-A- 5022114	21-09-89 15-12-94 05-01-95 11-06-91
-----			