



US 20080219793A1

(19) **United States**  
(12) **Patent Application Publication**  
Nolan

(10) **Pub. No.: US 2008/0219793 A1**  
(43) **Pub. Date: Sep. 11, 2008**

(54) **LINER FOR CONTAINER WITH SIDE DOOR**

**Publication Classification**

(76) Inventor: **Christopher S. Nolan**, Sellersburg, IN (US)

(51) **Int. Cl.**  
*B65D 63/00* (2006.01)  
*B61D 45/00* (2006.01)  
(52) **U.S. Cl.** ..... **410/97; 410/119**

Correspondence Address:  
**KING & SCHICKLI, PLLC**  
**247 NORTH BROADWAY**  
**LEXINGTON, KY 40507 (US)**

(57) **ABSTRACT**

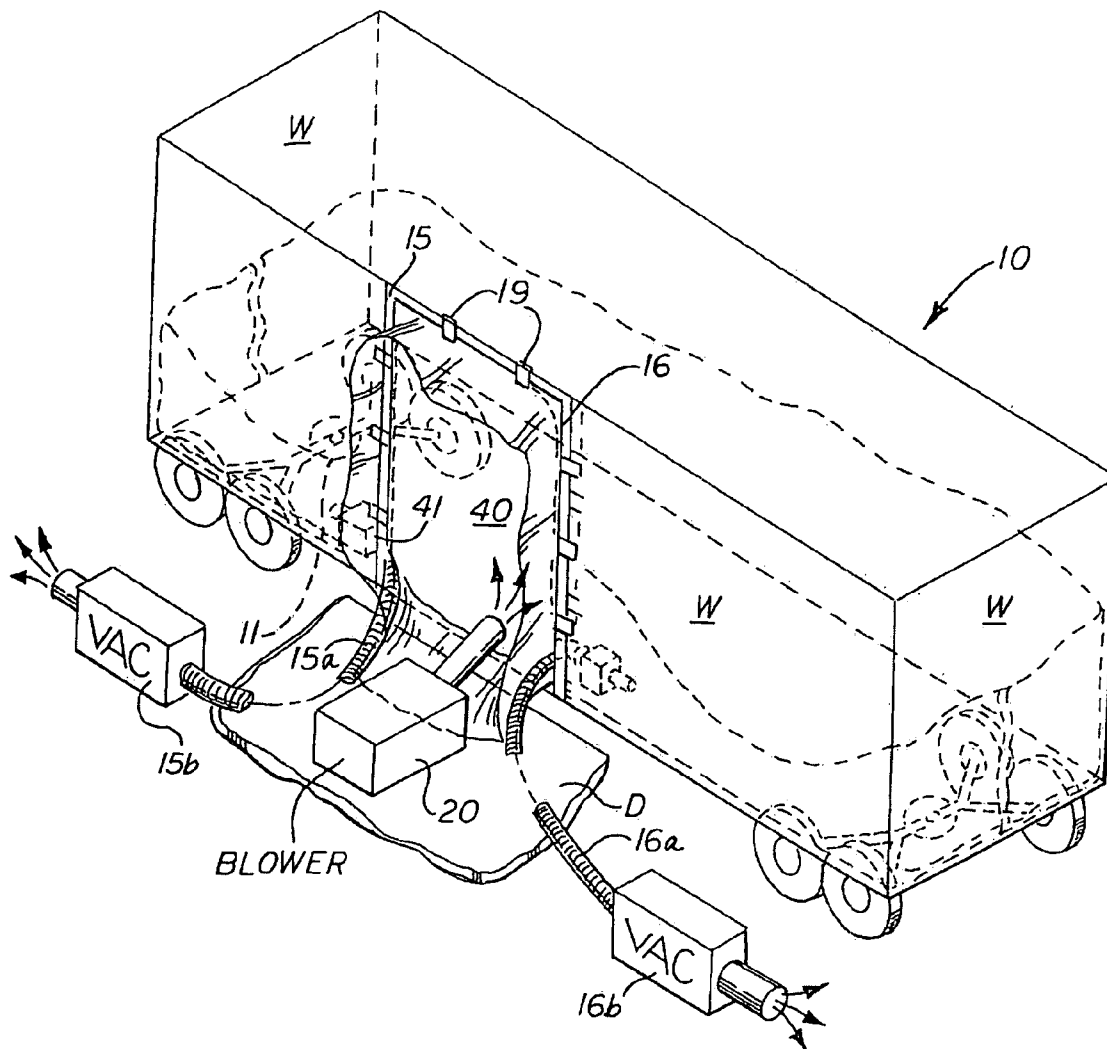
A moisture proof liner and method for installing the liner in an elongated container for shipping cargo is provided. The method may include the steps of providing said liner to be placed in the container, cutting an access opening in at least one of the side panels, attaching a lateral tube to form a transfer passage, positioning the liner in the container and erecting the liner by differential pressure, holding the tube open, transferring the cargo through the opening and closing the opening to seal the liner. The method may also include the steps of providing said liner, forming an access opening, and positioning said liner in the container such that the liner is free-standing.

(21) Appl. No.: **12/123,724**

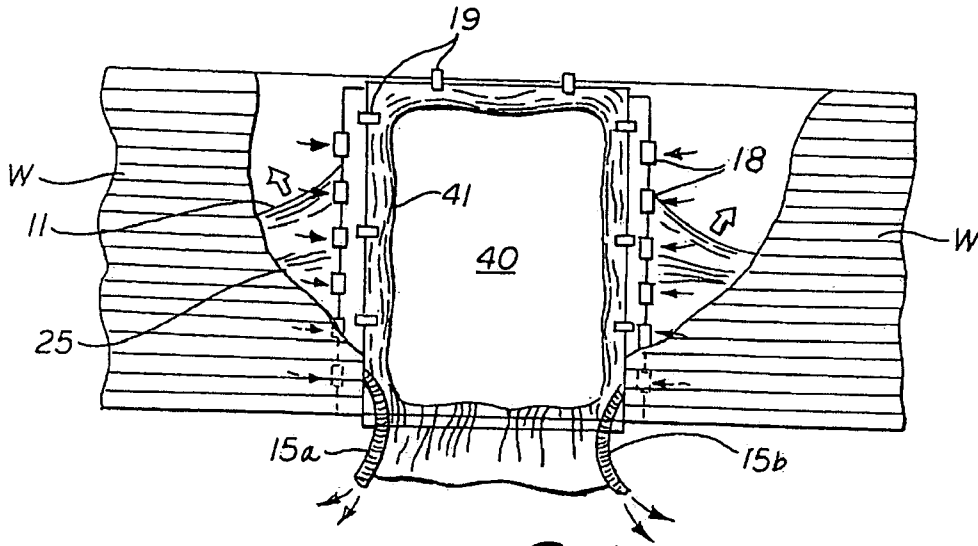
(22) Filed: **May 20, 2008**

**Related U.S. Application Data**

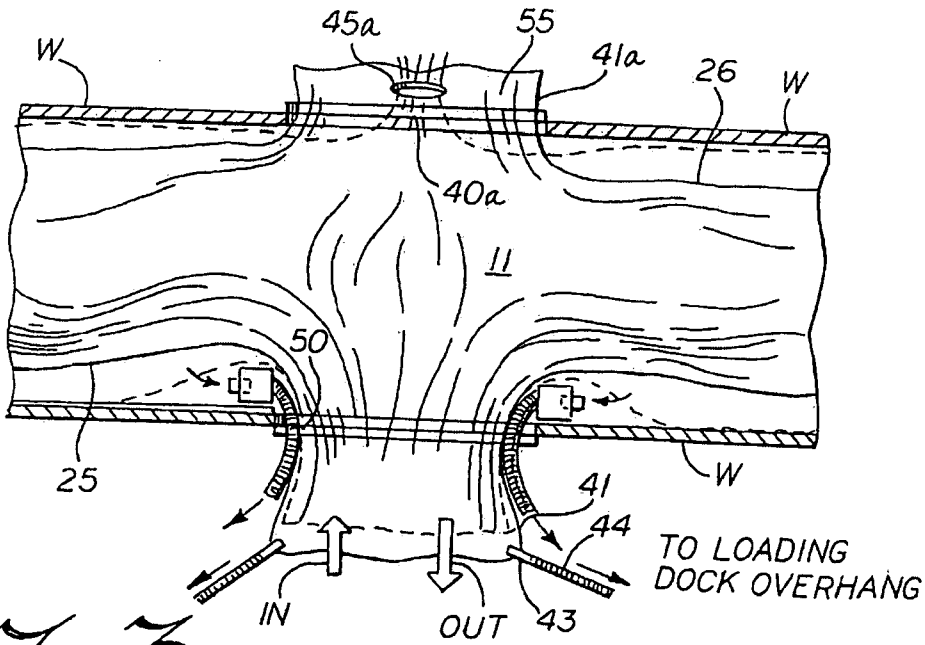
(62) Division of application No. 09/684,032, filed on Oct. 6, 2000.



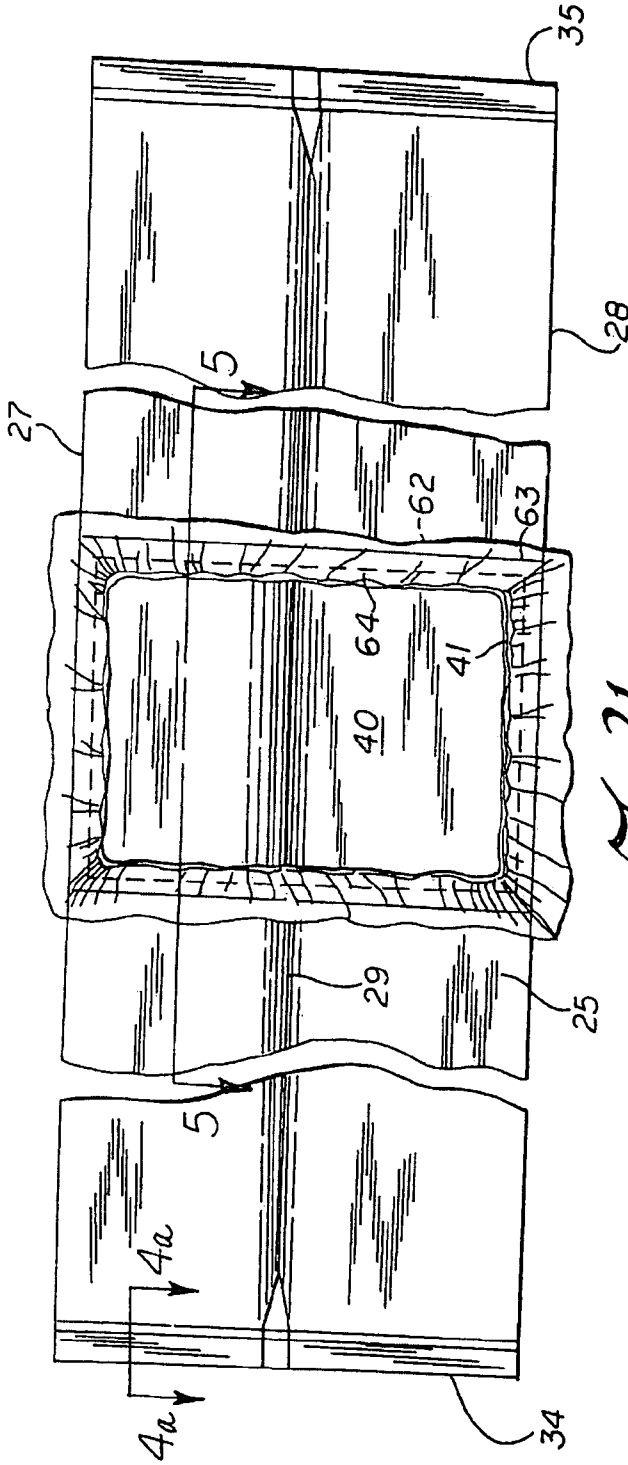




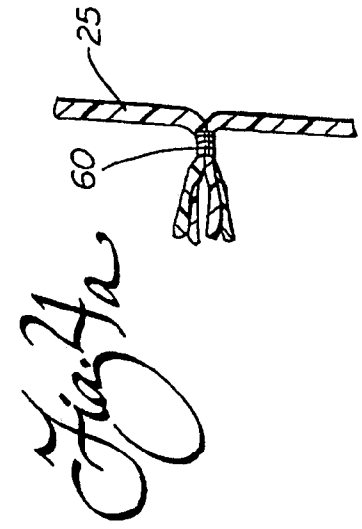
*Fig. 2*



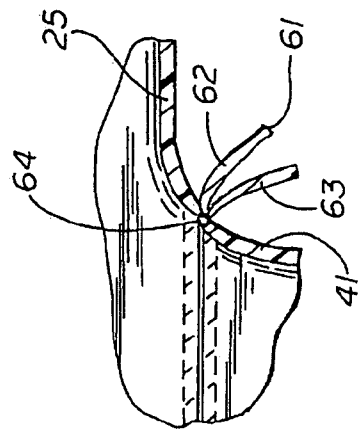
*Fig. 3*



*Fig. 4*



*Fig. 4a*



*Fig. 5a*

**LINER FOR CONTAINER WITH SIDE DOOR**

[0001] This application is a divisional of U.S. patent application Ser. No. 09/684,032 filed Oct. 6, 2000, which is herein incorporated by reference.

**TECHNICAL FIELD**

[0002] The present invention pertains to moisture proof liners for containers and, more particularly, to a liner and the related installation system where transfer of the cargo into and out of the container is through a side door.

**BACKGROUND OF THE INVENTION**

[0003] In the past, there have been many proposals for providing a liner in a cargo container for protection against moisture. This concept has found widespread use in transporting many types of cargo, including tobacco products, paper products and other articles that are particularly susceptible to moisture damage.

[0004] Going back several decades, one of the first approaches to the basic concept was to provide a bag for holding bulk material in an open dump trailer. Other related early approaches included placement of a flexible liner in a hopper-type trailer to allow the trailer to be converted to hauling of non-bulk articles. Other specialized applications for open trailers or trucks are described in the prior art patents and literature.

[0005] A departure from this early line of development is set forth in a series of issued U.S. patents, now owned by the assignee of the present invention. In particular, three of these patents are of importance in forming the background of the present invention; namely, U.S. Pat. Nos. 4,671,733, issued Jun. 9, 1987, 4,863,339, issued Sep. 5, 1989 and U.S. Pat. No. 5,059,084, issued Oct. 22, 1991. These commercially successful liner systems provide important background teachings as a basis for the present invention.

[0006] In contrast to the prior art represented by these patents, and others, there is a need for providing a system for cargo shipping containers, characterized by a side, rather than end door for transfer of the cargo into and out of the container. One example of such a container is a standard rail car having a side opening door. However, it is to be understood that the need applies to other containers, such as for semi-truck trailers with a side door, so as to be adapted for side platform cargo transfer, and side loading ship containers, as well as other like containers. In all instances, the need is for a cost effective way to protect vulnerable cargo from moisture damage. In addition, the ideal solution must provide for easy and rapid erection of the liner, rapid and protected loading of the cargo through an enclosed tube, and efficient closing of the container after loading. Furthermore, once the delivery location is reached, unloading must also be a simple process, including easy release of the closure and protected unloading of the cargo.

**SUMMARY OF THE INVENTION**

[0007] The present invention comprises a novel moisture proof liner for installation in an elongated container for shipping cargo, where the transfer of the cargo is through a side panel of the liner, which matches with the side door of the container. The side, top, bottom and end panels are formed of impervious film adapted to substantially match the corre-

sponding walls of the container when erected. An access opening is provided along at least one side panel through which the cargo is loaded and unloaded. After loading, a closure for the opening seals the liner against moisture to protect the cargo. At the transport destination, the closure is removed and the cargo is easily transferred out of the container onto the loading dock or platform. In some cases, it is desired to have loading and unloading capability from both sides of the container, and in this case a second opening is formed opposite the first opening to mate with the opposite door.

[0008] Preferably, the access opening includes an open tube attached at one end to form a passage for loading and unloading the cargo. Both the liner and the tube are formed of plastic sheet, preferably polyolefin film. The passage formed by the tube may be extended to a covered loading dock utilized to protect the dock personnel and cargo during the transfer operation during inclement weather.

[0009] In order to attach the end of the tube to the access opening of the liner, a peripheral heat seal bead is formed by applying heated sealing jaws across the overlapping flaps of the side access opening of the liner and the end of the tube. The side panels include gussets to allow expansion of the liner for substantially filling the container as it is erected. A vacuum is generated inside the container by vacuum manifolds to lift the liner into position until it is fully extended against the walls. If necessary or desirable, the initial erection process can be assisted by providing positive pressure from a blower through the tube and access opening. The end panels are formed by folded over sections, of the gusseted panels with a heat seal bead extending across the gussets.

[0010] In the related method, a liner having four panels of impervious film that matches the sides, top and bottom of the container, plus two end panels are provided. An access opening is cut vertically along at least one side panel, the liner is positioned in the container and erected so as to substantially fill the same. The cargo is transferred through the opening and finally the opening is closed to seal the liner against moisture so as to protect the cargo.

[0011] Preferably, an open ended tube is attached around the opening on the side panel and the cargo is passed through both the tube and the opening during its transfer. Additional method steps, referenced with respect to the liner as set forth above, include forming an opening on both sides of the liner. The upper corners of the free end of the tube may be attached by clips to overhead lines to hold the passage open during cargo transfer, and if sufficiently extended assist in protection during cargo transfer in inclement weather.

[0012] Still other novel features and advantages of the present invention will become readily apparent to those skilled in this art from the following description wherein there is shown and described a preferred embodiment of this invention, simply by way of illustration of one of the modes best suited to carry out the invention. As it will be realized, the invention is capable of other different embodiments, and its several details are capable of modifications in various, obvious aspects all without departing from the invention. Accordingly, the drawings and descriptions will be regarded as illustrative in nature and not as restrictive.

**BRIEF DESCRIPTION OF THE DRAWINGS**

[0013] The accompanying drawings incorporated in and forming a part of the specification, illustrate several aspects of

the present invention, and together with the description serve to explain the principles of the invention. In the drawings:

**[0014]** FIG. 1 is a perspective view of a rail car with a liner positioned in the bottom of the car, and with the liner erection just beginning through use of vacuum introduced into the rail car and/or positive pressure introduced into the liner;

**[0015]** FIG. 2 is an enlarged cut away side view showing the access opening formed in the liner and the liner initially attached by retainer clips to the doorway of the container and illustrating the flow of air generated by the vacuum continuing to lift the liner to the erected position;

**[0016]** FIG. 3 is a top view with a cross section through the walls of the container, and illustrating a second opening on the opposite wall of the container to allow transfer of cargo from either side;

**[0017]** FIG. 4 is an enlarged, cut away side view of the liner illustrating the manner of attachment of the transfer tube around the periphery of the access opening, and also illustrated in FIG. 4a is a detail of sealing the end panel by forming of a heat seal bead across the gusseted end; and

**[0018]** FIG. 5 is a cross sectional, cut away view of the liner of FIG. 4 illustrating in detail the attachment of the tube to the side panel of the liner, and in FIG. 5a illustrating the detail of the attachment across the overlapping flaps.

**[0019]** Reference will now be made in detail to the present preferred embodiment of the invention, an example of which is illustrated in the accompanying drawings.

#### DETAILED DESCRIPTION OF THE PREFERRED EMBODIMENT

**[0020]** With reference now to the drawings, and in particular to FIG. 1, a conventional rail car 10 is illustrated for purposes of disclosure of one use for a moisture proof liner 11 fabricated in accordance with the principles of the present invention. As illustrated in FIG. 1, the liner 11 is in the initial stages of being erected inside the container 10. As set forth in the prior U.S. Pat. Nos. 4,671,733, issued Jun. 9, 1987, 4,863,339, issued Sep. 5, 1989 and U.S. Pat. No. 5,059,084, issued Oct. 22, 1991 owned by the assignee of the present invention, a pair of upstanding manifolds 15, 16 are attached to vacuum hoses 15a, 16a to corresponding vacuum pumps or the intake side of blowers 15b, 16b. As the container 10 is evacuated on the inside through the arrays of orifices 17, 18 respectively (see FIG. 2), the liner 11 is progressively lifted into place corresponding to the walls W of the container 10 (note the flow arrows in FIG. 2, and the lift arrows of the liner 11). Retainer clamps 19 may be placed to extend around the doorway of the container in order to hold this section in place during the initial erection process. Also, positive pressure can be generated inside the liner 11 by a blower 20 positioned on loading dock D, if desired or necessary, especially for initial lift assist.

**[0021]** The particular structure of the moisture proof liner 11 in accordance with the present invention can be seen more in detail by reference also to FIGS. 4-5 of the drawings. Specifically, the liner 11 is formed of impervious film, such as polyolefin; however, it is to be understood that the film can be formed of other plastics or materials as long as the moisture sealing properties are sufficient. The liner 11 includes a first, elongated side panel 25 and an opposite like side panel 26. A top panel 27 and a bottom panel 28 are also illustrated (see the side view of FIG. 4). Each of the side panels 25, 26 includes a gusset 29, 30, which as illustrated in FIGS. 4 and 5, takes the form of an inward fold along the full length of the panels. This

allows the positioning of the liner in the bottom of the container 10 in a compact manner, as shown in FIG. 1. During erection, the inward gussets 29, 30 do, of course, straighten so that the full height of the container can be filled with the liner 11.

**[0022]** First and second end panels 34, 35 complete the liner 11 and these are formed by folding over the gusseted end sections and then heat sealing, as will be explained later in detail.

**[0023]** In accordance with the present invention, an access opening 40 is cut into at least the one side panel 25 and is adapted for loading and unloading the cargo. An open tube 41 is attached by heat sealing to the side panel 25 in a manner also to be described below. This tube 41 provides for a protected passage during transfer of cargo into and out of the liner (see the action arrows of FIG. 3). The free end of the tube 41 may be held open at the upper corners by clips 43 and attached overhead lines 44 (see FIG. 3). Ideally, the tube 41 extends a sufficient distance so that protection from inclement weather is afforded when the lines 44 can be attached to the loading dock overhang. Once the cargo is moved into position in the liner 11, a closure is applied in order to protect from entry of moisture (see FIG. 5 of the drawings). The closure may be formed by a tie or crimp ring 45 holding a gathered section of the tube 41.

**[0024]** As illustrated, the access opening 40 is preferably positioned at approximately the midpoint of the side panel 25, which corresponds to a conventional rail car side doorway 50 (see open position in FIG. 3). It is to be understood that in accordance with the broadest aspects of the present invention, the container 11 may be another type of container, such as a truck trailer or container for an ocean going vessel so long as the opening is on the side.

**[0025]** In accordance with another aspect of the present invention, a second doorway 55 can be made functional on the opposite side of the container 10 through a second opening 40a and tube 41a. As will be appreciated, cargo can then be transferred into and out of the liner 11 from both (or either) sides. In the dotted line position, the tube 41a can also be closed by a crimp ring 45a.

**[0026]** With reference to FIGS. 4-5, the related method of the present invention can be reviewed in detail. The liner 11 is originally formed as an extruded tube with the gussets 29, 30 folded in and extending along the full length. In the preferred embodiment, the gussets extend inwardly to approximately the longitudinal midpoint. When expanded, the liner 11 thus expands to a height of two times the width, which approximates the dimensions of a standard rail car or truck trailer.

**[0027]** To form the end panels 34, 35, the gusseted liner is folded across the ends and a heat seal bead 60 is formed, thus closing the liner 11. To form the heat seal bead 60, conventional heated sealing jaws (not shown) may be used to squeeze the plies of plastic together. The heat is just sufficient to melt and fuse the plastic together to form a moisture proof barrier.

**[0028]** Once the end panels are formed, the liner 11 is in the form of a closed bag. In accordance with the preferred embodiment of the invention, the access opening 40 is cut into the side panel 25. The cut forms the raw edge 61 that is folded back on the side panel 25, as best seen in FIG. 5a, and forms a first flap 62. The tube 41 is folded back on the adjacent end to provide a corresponding second flap 63. To seal the tube 41 to the liner 11, a heat seal bead 64 is provided by applying heat and pressure through conventional sealing jaws (not shown).

[0029] In summary, the results and advantages of the present invention can now be readily understood. The liner 11 includes two elongated side panels corresponding to the sides 25, 26 of the container, along with the corresponding top and bottom 27, 28. The sides include the gussets 29, 30 extending along the full length and the ends are folded over to form moisture proof end panels 34, 35. The access opening 40 is formed by cutting through at least one side panel 25 to allow transfer of the cargo in and out of the container 10. The tube 41 is attached by heat sealing along the corresponding flaps 62, 63. By gathering the free ends of the tube, applying the tie or crimp ring 45 and tucking it into the container, the protection of the cargo from moisture is assured. The opposite side panel 26 can also be provided with an access opening 40a, if desired for faster cargo transfer. The liner 11 is thus characterized by providing an efficient and economical way to protect cargo in a side door container, such as a rail car or truck trailer. The liner is easily erected into position in the container and rapid, easy and protected loading and unloading is assured.

[0030] The foregoing description of the preferred embodiment of the invention has been presented for purposes of illustration and description. It is not intended to be exhaustive or to limit the invention to the precise form disclosed. Obvious modifications or variations are possible in light of the above teachings. The embodiment was chosen and described to provide the best illustration of the principles of the invention and its practical application to thereby enable one of ordinary skill in the art to utilize the invention in various embodiments and with various modifications as are suited to the particular use contemplated. All such modifications and variations are within the scope of the invention as determined by the appended claims when interpreted in accordance with the breadth to which they are fairly, legally and equitably entitled.

1. A method of installing a moisture proof liner for an elongated container for use in shipping cargo, comprising the steps of:

- providing said liner having four elongated panels of impervious film adapted to substantially match the elongated sides, top and bottom of said container and first and second end panels to complete said liner;
  - cutting an access opening along at least one side panel adapted for loading and unloading said cargo;
  - positioning said liner in the container;
  - erecting the liner to substantially fill the same;
  - transferring said cargo through said opening; and
  - closing the opening to seal said liner against moisture to protect the cargo.
2. The method of installing a liner of claim 1, wherein is further provided the step of:
- attaching an open ended tube to said one side panel to mate with the opening; and
  - passing said cargo through both said tube and said opening during transfer.
3. The method of installing a liner of claim 2, wherein is further provided the step of:
- holding open the free end of said tube overhead by lifting the upper corners and for protection from increment weather during cargo transfer.
4. A method of installing a liner for an elongated container for use in shipping cargo, comprising the steps of:
- providing said liner having four elongated panels of impervious film adapted to substantially match the elongated sides, top and bottom of said container and first and second end panels to complete said liner;
  - forming an access opening along at least one side panel adapted for loading and unloading said cargo; and
  - positioning said liner in the container such that said liner is free-standing.
5. The method of installing a liner of claim 4, wherein the positioning step includes using air to erect the liner.

\* \* \* \* \*