

**(12) STANDARD PATENT**  
**(19) AUSTRALIAN PATENT OFFICE**

(11) Application No. **AU 2012200541 B2**

(54) Title  
**Method for providing location-specific data services**

(51) International Patent Classification(s)  
**H04L 12/00** (2006.01)

(21) Application No: **2012200541** (22) Date of Filing: **2012.01.31**

(30) Priority Data

(31) Number	(32) Date	(33) Country
<b>11450034.1</b>	<b>2011.03.11</b>	<b>EP</b>

(43) Publication Date: **2012.09.27**

(43) Publication Journal Date: **2012.09.27**

(44) Accepted Journal Date: **2014.07.31**

(71) Applicant(s)  
**Kapsch TrafficCom AG**

(72) Inventor(s)  
**Guner, Refi-Tugrul**

(74) Agent / Attorney  
**FB Rice, Level 23 44 Market Street, Sydney, NSW, 2000**

(56) Related Art  
**EP 1431946**

Abstract

Method for providing place-specific data services

5 A method for providing location-specific data services (13) to vehicles (1) that carry onboard units (5) for short-range communication (6) with tolling stations (3) at known locations ("pos") in a road-tolling system as well as mobile terminals (10) for data reception (11) in a mobile communication network (12), comprising:

10 Storing a list (17) of service IDs (A-SID), a mapping (19) between a device ID (OID) and a terminal ID (MID), and at least one booking (18) of a service ID (B-SID) for a device or terminal ID (OID, MID) within the road tolling system;

Transmitting the device ID (OID) of an onboard unit (5) to the tolling station (3) by means of short-range communication (6, 7, 7');

Retrieving the booking of the service ID (18) for said device ID or corresponding terminal ID (OID, MID);

15 Testing whether the service ID (B-SID) from this booking (18) is included in the service ID list (17) of this tolling station (3), and if so, transmission of the corresponding terminal ID (MID) to the data service (13) identified by the service ID (SID); and

20 Providing this data service (13, data) via the mobile communication network (12) to the mobile terminal (10).

(Fig. 1)

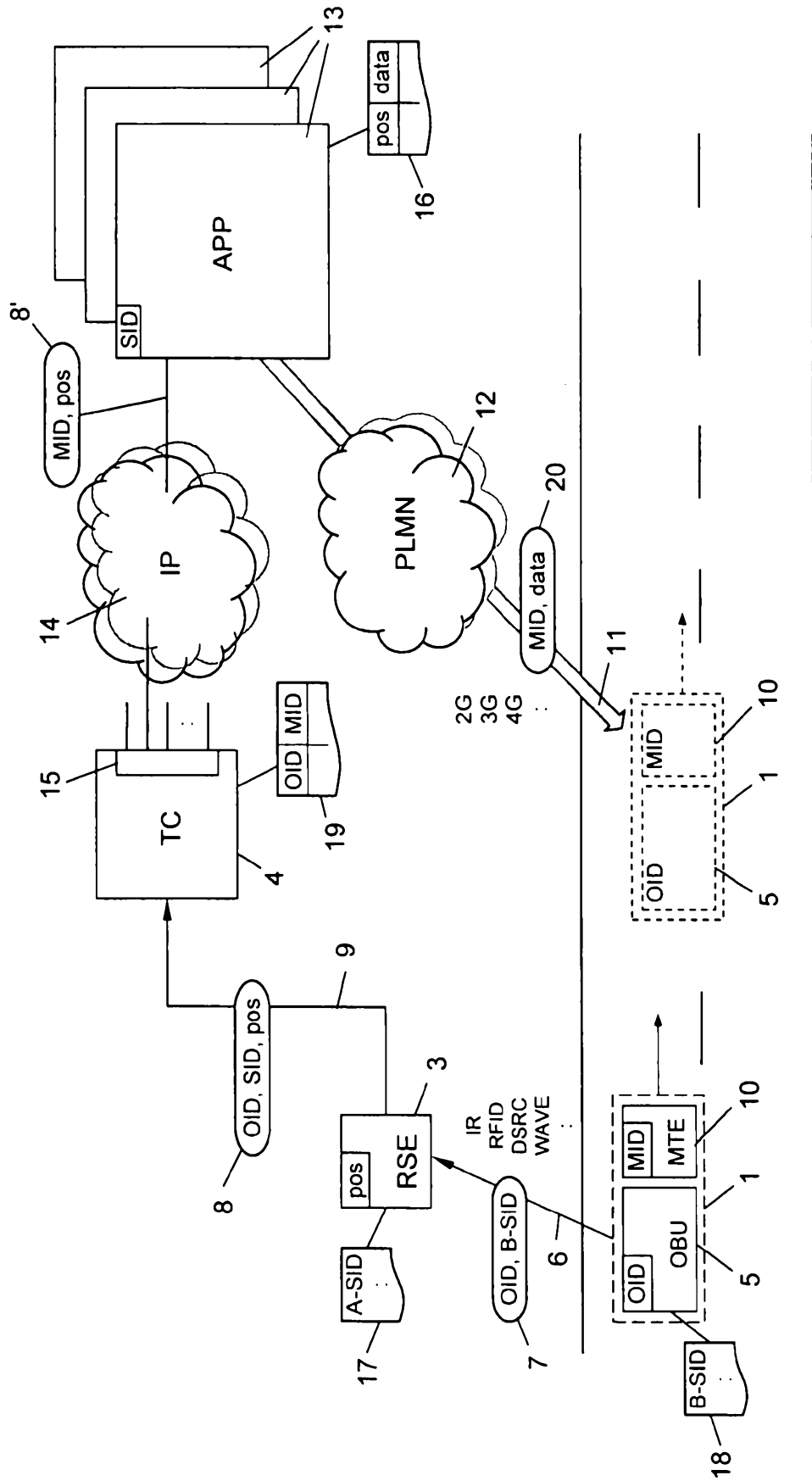

Fig. 1

# AUSTRALIA

## Patents Act 1990

**KAPSCH TRAFFICOM AG**

**COMPLETE SPECIFICATION  
STANDARD PATENT**

*Invention Title:*

*Method for providing location-specific data services*

The following statement is a full description of this invention including the best method of performing it known to us:-

## METHOD FOR PROVIDING LOCATION-SPECIFIC DATA SERVICES

The present invention relates to a method for providing location-specific data services to vehicles that are equipped with onboard units for short-range communication with toll stations at known positions in a road-tolling system, as well as mobile terminals for receiving data in a mobile communication network.

Road tolling systems that employ a network of geographically distributed toll stations with locally bounded communication zones in order to localize vehicles to the location of the tolling station via short-range communication with their on-board units (OBUs) are distinguished by their high reliability and precise localization. However, the quantity of data that can be exchanged via these short-range communications is sharply limited by the limited range thereof and the speed of the vehicles. In general, only a brief data message is possible, which must contain the device code of the onboard unit in order to identify it within the road tolling system before the vehicle again leaves the communication zone of a tolling station. High-volume mobile data services are currently used over 2G, 3G or 4G mobile communication networks (GPRS, UMTS or LTE, etc.) with mobile terminals such as mobile telephones, PDAs, handheld PCs, tablets, etc., which are brought by the user in the vehicle or can be integrated into the vehicle or the onboard unit thereof. The localization precision of mobile terminals in these mobile communication networks, however, is greatly limited for the purpose of location-specific data services, even if additional GPS receivers are installed, and also has the consequence of increased data traffic in the mobile communication network, with corresponding additional costs.

Any discussion of documents, acts, materials, devices, articles or the like which has been included in the present specification is not to be taken as an admission that any or all of these matters form part of the prior art base or were common general knowledge in the field relevant to the present invention as it existed before the priority date of each claim of this application.

Throughout this specification the word "comprise", or variations such as "comprises" or "comprising", will be understood to imply the inclusion of a stated element, integer or step, or group of elements, integers or steps, but not the exclusion of any other element, integer or step, or group of elements, integers or steps.

According to the present invention there is provided a method for providing location-specific data services to vehicles that carry onboard units for short-range communication with tolling stations at known locations in a road-tolling system as well as mobile terminals for data reception in a mobile communication network, wherein the onboard units have unique device IDs, the mobile terminals have unique terminal IDs, and the data services have unique service IDs, are registered to one or more application servers connected to the mobile network, and are connected via data connections to the tolling stations, comprising:

storing a list of service IDs of data services related to the location of a tolling station in this tolling station, a mapping between the device ID and the terminal ID of a vehicle in the road tolling system, and at least one booking of a service ID for a device or terminal ID within the road tolling system;

transmitting the device ID of an onboard unit passing a tolling station to the tolling station by means of short-range communication;

retrieving the service ID booking for said device ID or corresponding terminal ID;

testing whether the service ID from this booking is included in the service ID list of location-specific data services for this tolling station, and if so, transmitting the corresponding terminal ID to the data service identified by the service ID, and providing location-specific data by this data service via the mobile communication network to the mobile terminal identified by the terminal ID.

The invention depends on the understanding that a high-volume data service with high localization precision can be provided via the present infrastructure of a network of geographically distributed tolling stations in a road tolling system in combination with a mobile communication network. At every tolling station – or delegated to a proxy or a control center of the road tolling system – the data services booked by a passing onboard unit are compared to the data services available at the tolling station location, so as to prevent unnecessary data traffic and the disturbance of the driver by irrelevant information. The driver can subscribe or book precisely those data services that are of interest or relevant to safe operation. So, for example, traffic-relevant information with a high data volume, e.g. graphically complex traffic maps, weather maps showing precipitation and freezing zones, etc., can be provided in a location-specific way, and location-specific application calls can be initiated, e.g. mobile-terminal payment transactions, etc. The term "data service" used herein in this sense includes arbitrary applications including those named above.

It may be mentioned here that the broadcasting of Bluetooth-beacon advertising links (URLs) to passing mobile telephone users has been disclosed in US 70 10 267 and WO 2001/01711 for the distribution of location-specific advertising, in order to prompt

2012200541 12 Feb 2014

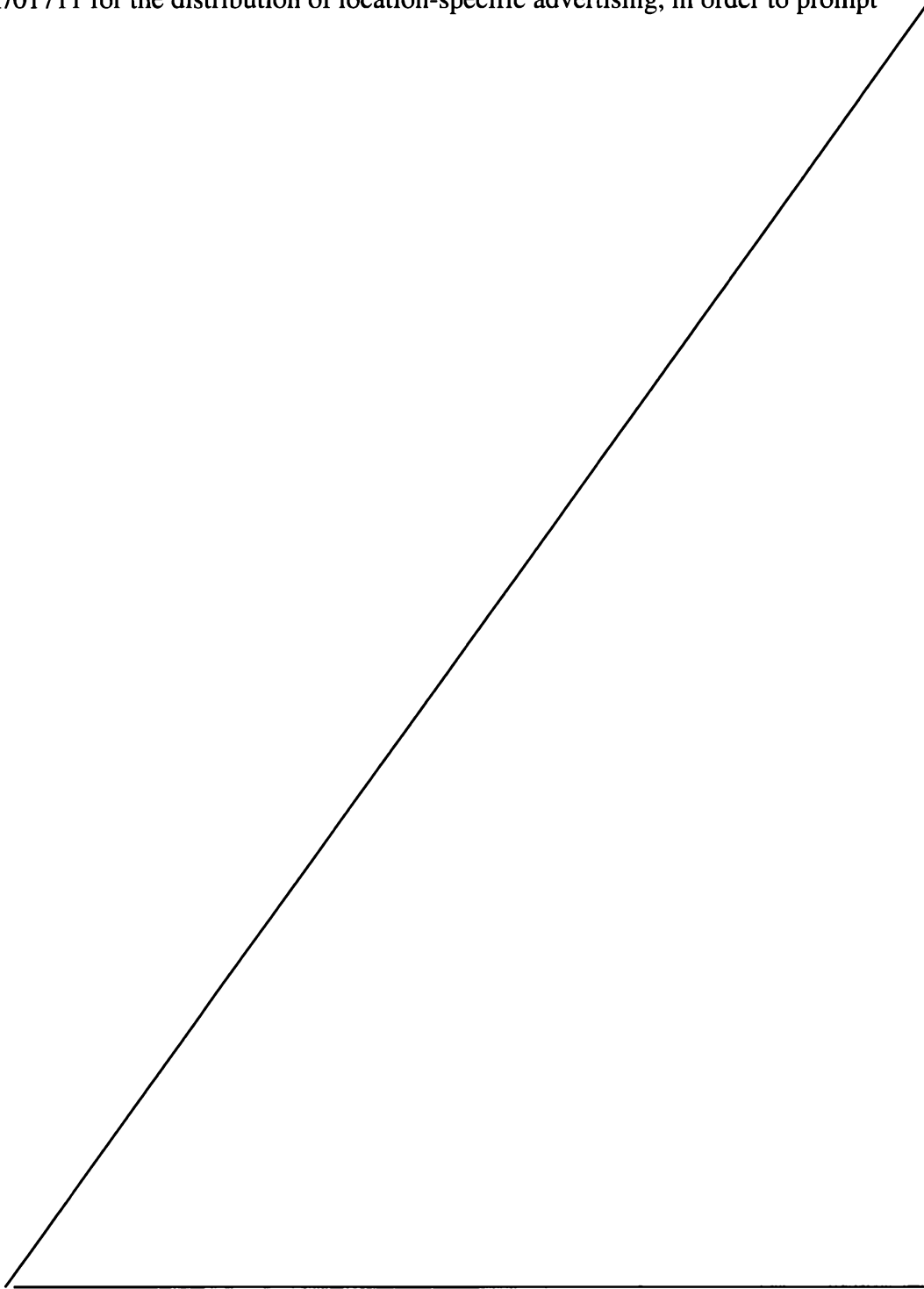

these users to call up additional information via the mobile internet. A solution of this type requires a separate network of Bluetooth beacons and is unsuited for safety-relevant traffic applications, since it requires the attention and interaction of the user for information exchange, which puts the safe operation of the vehicle at risk.

5

It is preferable that the list of service IDs of the data services related to a tolling station at the location be stored in this same tolling station, and that the retrieval of the service ID entry for the named device or assigned terminal ID take place in this same tolling station, which enables a rapid on-site reaction – i.e. in this tolling station – to this passing onboard unit, without the tolling station needing to refer to a remote proxy or control center.

10

In a first embodiment of the invention, the location-specificity of the data service is ensured by means of its service ID, i.e. each service ID stands for a data service that is specific to the tolling station location. In a further embodiment of the invention, it may be preferred that the tolling station location also be sent along with the terminal ID to the identified data service, so that the data service can more precisely adapt its services or data to the tolling station location. For example, a data service identified by its service ID may be available over a greater area with multiple tolling stations, adapting its data or services specifically to the tolling station location currently relayed.

15

20

In the preferred embodiments of the invention, the service ID entry is stored in a list at the tolling station or at a control center of the road tolling system, and said retrieval of the service ID entry takes place with reference to this list in the tolling station or control center. The user can for example enter the desired data services under his/her device or terminal ID into a central list of the road tolling system, which can then optionally be distributed to all tolling stations. Communication between the onboard unit and tolling station can thus be kept to a minimum and also requires no modification with respect to the customary road tolling standards.

25

30

Alternatively, the service ID entry can be stored in the onboard unit, and said retrieval of the service ID entry takes place by this/these booked service ID(s) being sent to the tolling station together with the device and/or terminal ID of the onboard unit. This variation has the advantage that the user does not have to book his/her services centrally in the road tolling system, but can do it locally on his/her onboard

35

unit, which affords clear runtime advantages in the processing of the service, particularly for locally restricted services.

5 The specified mapping between device ID and terminal ID can also be done at different places in the system. In a first variation, the mapping between device ID and terminal ID is stored in a list at a control center of the road tolling system, by means whereof it is sent to the data service, and whereat the terminal ID mapped to the device ID is retrieved with reference to the list. This thus requires a corresponding central registration in the road tolling system, but simplifies communication between onboard  
10 units and tolling stations. The specified mapping list can also be distributed to the tolling stations by the control center, so that the terminal ID assigned to the device ID can be retrieved with reference to the local list in the tolling station, which enables accelerated processing.

15 In a further variation, the terminal ID mapped to the device ID can be stored within the onboard unit and sent by this unit to the tolling station, which eliminates the need for a central registration but also requires corresponding modification to the short-range communication.

20 The method of the invention is suited for an arbitrary road tolling system, with any of the different types of short-range communication, e.g. infrared, RFID (radio frequency identification) or WLAN (wireless local area network). It is especially advantageous if the short-range communication follows the DSRC (dedicated short range communication) or WAVE (wireless access in a vehicle environment) standards,  
25 which are widely used in road tolling systems with geographically distributed tolling stations.

Hereinafter, the invention will be described in greater detail with reference to the embodiments presented in the attached drawings. Referring to the drawings:

30

Figure 1 shows a first embodiment of the method of the invention, in the context of a schematically-rendered road tolling system; and

35 Figures 2 and 3 show variations of the method of Figure 1 with reference to a section of the road tolling system of Figure 1.

According to Figure 1, vehicles 1 move on a road 2 in the context of a road tolling system, which comprises a plurality of geographically distributed tolling stations 3 (only one shown) and at least one control center 4. The vehicles 1 carry vehicle devices or onboard units (OBUs) 5, which can engage in short-range communication 6, i.e. wireless communication over tightly circumscribed ranges with the tolling stations 3 when they pass these or enter their range.

The onboard units 5 have unique device IDs (OBU IDs) OIU within the road tolling system with which they identify themselves (report 7) to the tolling stations 3 in the course of short-range communication 6. After an onboard unit 5 has passed, a tolling station 3 can thus transmit a tolling transaction 8 to the control center 4 via a data connection 9; this tolling transaction 8 includes at least the device ID OIU of the onboard unit 5 and the location pos of the tolling station 3. The tolling station location pos can also be furnished in the form of a unique ID of the tolling station 3 if the control center 4 knows the locations of the tolling stations 3.

In the control center 4, a toll or fee can be imposed for a use of the tolling station location pos by the vehicle 1 based on the received tolling transactions 8; for example, the traversal of a tolled road, entry into a toll-mandatory district, or staying at a toll-mandatory location, etc., as will be understood by a person of skill in the art.

For the short-range transmissions 6, different technologies can be employed, such as infrared (IR), RFID (radio frequency identification), DSRC (dedicated short range communication), WLAN (wireless local area net), WAVE (wireless access in a vehicle environment), ZigBee<sup>®</sup>, Bluetooth<sup>®</sup>, etc. It is preferred that it be a DSRC or WAVE connections, which are employed in typical road tolling systems.

The vehicle 1 carries a mobile terminal 10 in addition to the onboard unit 5; this may be integrated into the onboard unit 5, connected to it or separate from it. The mobile terminal 10 is a mobile terminal device for data reception 11 in a mobile communication network 12 of the second, third, fourth, etc. generation (2G, 3G, 4G etc.), preferably in accordance with the GSM, UMTS, LTE or WIMAX standard. To this end, the mobile terminal 10 is e.g. a mobile transceiver integrated into the onboard unit 5 or a tablet, handheld PC or mobile telephone designed for data reception, and may be either "stand-alone" or integrated into an electronic system of the vehicle 1.

The mobile terminal 10 is identified in the mobile communication network 12 by means of a unique terminal ID (mobile ID) MID. The terminal ID MID can for example be a telephone number, IMSI, IMEI or IP address in the mobile communication network 12.

5

Via the mobile communication network 12, location-specific data services 13 can be received in the mobile terminal 10 or used by it, e.g. also interactively. The data services 13 are for example registered to one or more application servers (not shown), which are connected to the mobile communication network 12 either directly or via

10

The data services 13 are further connected via data connections 14, preferably the Internet, to the tolling stations 3, and preferably via the control center 4 of the road tolling system. To this end, the control center 4 can e.g. have an internet gateway 15 for communication with Internet-based data services 13. If the control center 4 is absent, the data services 13 or the application servers that provide them are connected directly to the tolling stations 3 via the data connections 9, 14.

15

The data services 13 have a unique service ID SID by which they can be identified, e.g. a URL (uniform resource locator) in the Internet. Every data service 13 is specifically for the location pos of one (or more) tolling stations 3, i.e. a location-specific data service in this sense. In addition, a data service 13 can also provide data specifically adapted to the current tolling station location pos or provide "data" to services, as symbolized by the list 16.

20  
25

The tolling station 3 contains its own list 17 with the service ID SID of those data services 13 that are available or providable for its location. The entries in the service ID list 17 are here indicated as "A-SID" (available SIDs).

30

In the onboard unit 5, there is likewise a list 18 of the data services 13 desired or "entered" by it, respectively referenced by a service ID SID, here indicated in the list 18 as "B-SID" (booked SIDs). Every entry in the list 18 thus represents a "service ID booking" of the OBU 5 with the device ID OID with respect to a data service 13 with the service ID SID. The list 18 can be stored in the OBU 5 upon preparing the OBU 5 or furnishing it to the user, and/or installed or modified via a user interface or "on the fly" during operation.

35

Upon passing a tolling station 3, in the course of short-range communication 6 the OBU 5 also relays the list 18 of the data services booked by it B-SID as well as its device ID OID, see report 7. At the tolling station 3, it is checked whether one (or more) of the booked service IDs B-SID is included in the list 17 of data services 13 available at the tolling station location pos. If so, i.e. if a booked service ID B-SID matches an available service ID A-SID, this service ID (A- or B-) SID is sent to the control center 4 via the data connection 9 as a toll transaction 8 together with the device ID OID and (optionally) the tolling station location pos.

The service ID list 17 may alternatively be held in the control center 4 or at an intermediate proxy computer (not shown), rather than in the tolling station 3; in this case, said comparison between the booked data services B-SID and the data services available at the tolling station location A-SID can also be outsourced to the control center 4 or the proxy computer.

A list of mappings 19 between the device IDs OID of the onboard units 5 and the terminal IDs MID of the mobile terminals 10 is kept in the control center 4. To construct the list 19, the user of the vehicle 1 can for example register at the control center 4 with his/her device and terminal IDs OID, MID, e.g. via the Internet 14 or a Point-of-Sale Terminal (not shown) connected to the control center 4.

At the control center 4, the terminal ID MID that maps to a received device ID OID is retrieved based on the list 19, and is entered in a modified transaction report (8') instead of (or in addition to) the device ID OID; this report is sent via the Internet 14 to the data service 13 indicated by the service ID SID. The data service 13 with the service ID SID receives the terminal ID MID and -- provided it is available (report 20) at multiple station locations pos -- optionally also the station location, and provides its location-specific data data -- possibly dependent on location -- via the mobile communication network 12 to the mobile terminal 10 identified by the terminal ID MID. The mobile terminal 10 can respond directly to the receipt of the report 20 and use or display the location-specific data data of the service 13 contained therein, or if there is a connection between the onboard unit 5 and mobile terminal 10, it can be put into a specific standby mode by the onboard unit 5.

The location specific data data (report 20) can for example be an SMS, voice-mail or the display of a website or graphic, or a "remote process call" (RPC) to start or trigger an application.

5 Figure 2 shows a variation of the method of Figure 1, wherein the service ID bookings of the onboard unit 5 are not stored therein, but in a list 21 at the tolling station 3. The list 21 contains the service IDs B-SID booked to a device ID OID. The list 21 is preferably distributed by the control center 4 to all its tolling stations, and can for example be provided when furnishing the list 19. The onboard unit 5 therefore only  
10 needs to send its device ID OID (report 7) to a tolling station 3 in the usual manner by means of a short-range communication 6; the tolling station 3 retrieves the data services or service IDs B-SID booked for the received device ID OID based on the booking list 21, in order to compare it with the list 17 of the available service IDs A-SID and in the case of a match, to transmit the reports 8,8' to the corresponding data service 13 via the  
15 control center 4.

Figure 3 shows a further alternative form of the method of Figures 1 and 2, wherein the list 19 is furnished directly to the tolling station 3. The mapping of the terminal ID MID to the device ID OID here occurs right at the tolling station 3, so that  
20 a modified report 8' can be transmitted via the data connection 9 to the control center 4, wherein the terminal ID MID appears in place of the device ID OID. It will be apparent that this variation can be combined with the embodiment of Figure 1 as well as with that of Figure 2.

25 A further variation of the mapping between device ID OID and terminal ID MID involves the terminal ID MID being stored directly in the OBU 5 with the device ID OID thereof, or the OBU 5 – if this is connected with the mobile terminal 10 – containing the terminal's terminal ID MID. In this case, the terminal ID MID can be sent to the tolling station 3 instead of (or in addition to) the device ID OID in the report  
30 7 or 7'. This variation can also be combined with each of the embodiments shown in Figs. 1-3.

Billing for the location-specific data data or data services 13 can be performed by the control center 4, by the application server of the data services and/or by the  
35 operator of the mobile communication network 12.

The invention is not limited to the embodiments presented, but includes all variations and modifications that fall within the scope of the attached claims.

THE CLAIMS DEFINING THE INVENTION ARE AS FOLLOWS:-

1. A method for providing location-specific data services to vehicles that carry onboard units for short-range communication with tolling stations at known locations in a road-tolling system as well as mobile terminals for data reception in a mobile communication network, wherein the onboard units have unique device IDs, the mobile terminals have unique terminal IDs, and the data services have unique service IDs, are registered to one or more application servers connected to the mobile network, and are connected via data connections to the tolling stations, comprising:

storing a list of service IDs of data services related to the location of a tolling station in this tolling station, a mapping between the device ID and the terminal ID of a vehicle in the road tolling system, and at least one booking of a service ID for a device or terminal ID within the road tolling system;

transmitting the device ID of an onboard unit passing a tolling station to the tolling station by means of short-range communication;

retrieving the service ID booking for said device ID or corresponding terminal ID;

testing whether the service ID from this booking is included in the service ID list of location-specific data services for this tolling station, and if so, transmitting the corresponding terminal ID to the data service identified by the service ID, and providing location-specific data by this data service via the mobile communication network to the mobile terminal identified by the terminal ID.

2. The method of Claim 1, wherein the tolling station location is also sent to the identified data service along with the terminal ID, and is applied by the service.

3. The method of Claim 1 or 2, wherein the service ID booking is stored in a list at the tolling station and said retrieval of the service ID booking is done at the tolling station with reference to this list.

4. The method of Claim 1 or 2, wherein the data services are connected to the tolling stations via a control center of the road tolling system, and wherein the service ID booking is stored in the onboard unit and said retrieval of the service ID booking is done by sending this to the tolling station together with the device and/or terminal ID.

5. The method of any one of Claims 1 to 4, wherein the mapping between device ID and terminal ID is stored in a list at a control center of the road tolling system, via which the transmission to the data service takes place and where the terminal ID mapped to the device ID is retrieved with reference to the list.

6. The method of any one of Claims 1 to 4, wherein the mapping between device ID and terminal ID is stored in a list at the tolling station, where the terminal ID mapped to the device ID is retrieved with reference to the list.

7. The method of any one of Claims 1 to 4, wherein the terminal ID mapped to the device ID is stored in the onboard unit and sent by it to the tolling station.

8. The method of any one of Claims 1 to 7, wherein the short-range communication takes place according to the DSRC or WAVE standard.

9. A method for providing location-specific data services to vehicles substantially as hereinbefore described with reference to the accompanying drawings.

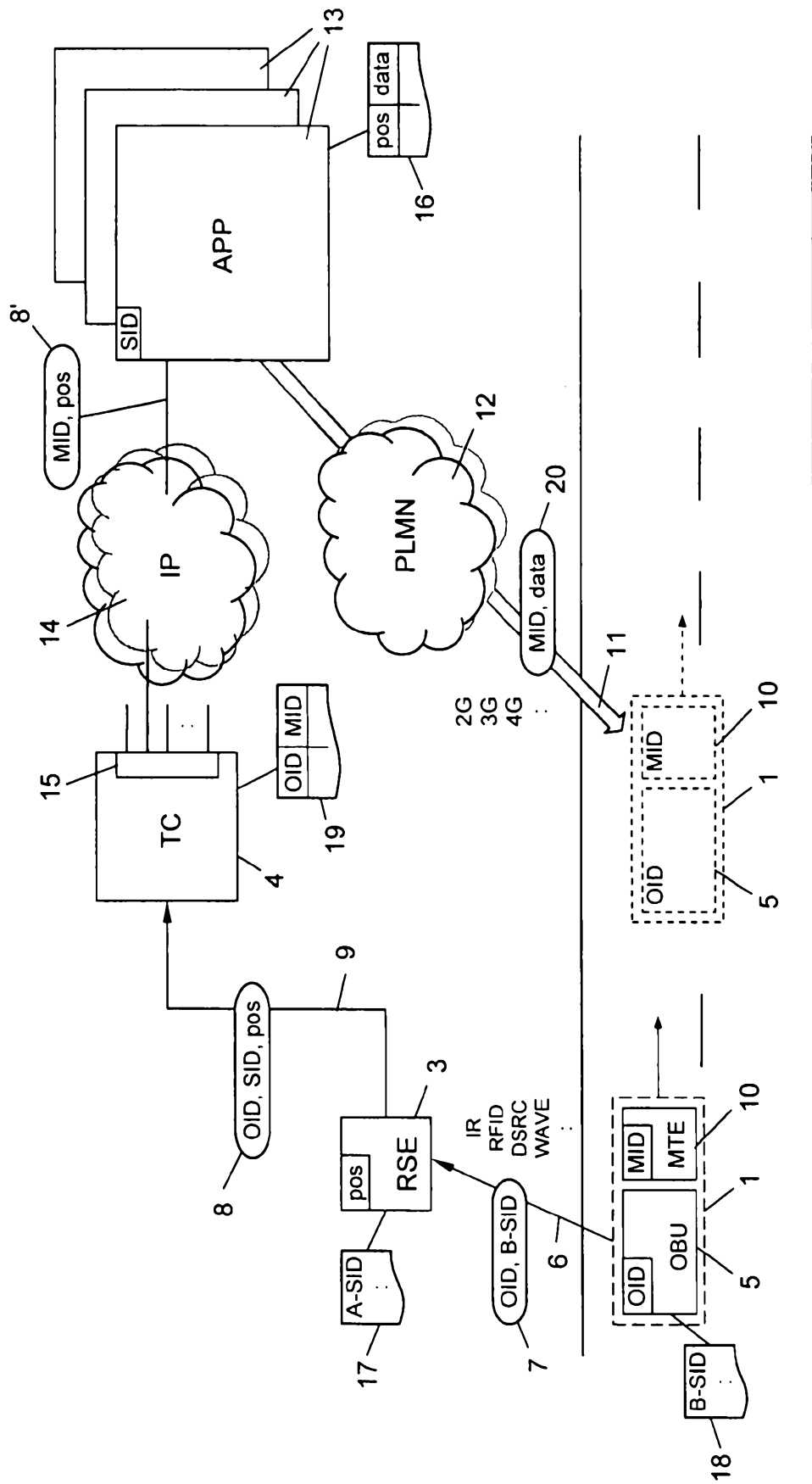

Fig. 1

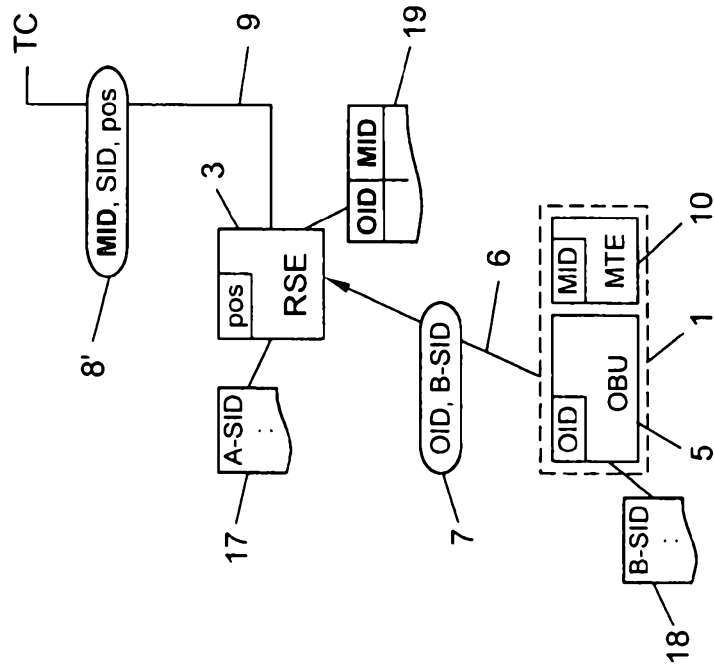

Fig. 2

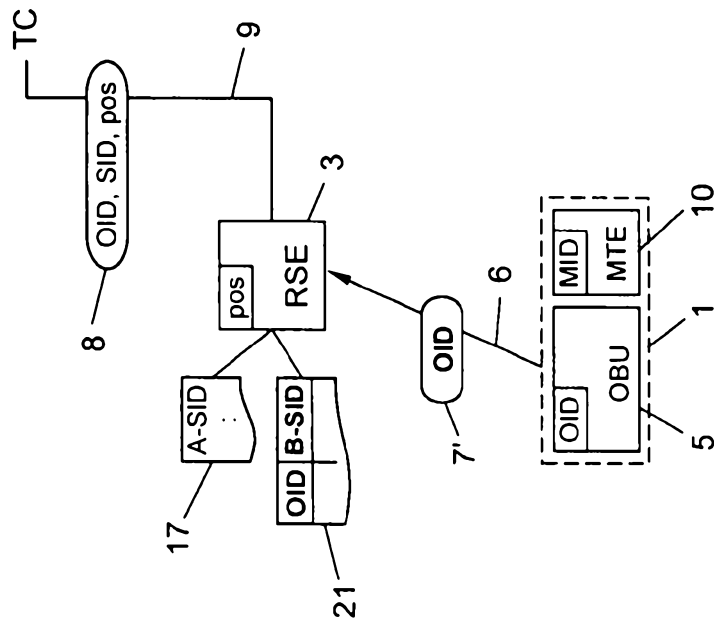

Fig. 3