



- (51) International Patent Classification:
A61J 7/00 (2006.01) G06Q 50/04 (2012.01)
A61J 7/04 (2006.01)
- (21) International Application Number:
PCT/US2017/020959
- (22) International Filing Date:
6 March 2017 (06.03.2017)
- (25) Filing Language: English
- (26) Publication Language: English
- (30) Priority Data:
15/073,096 17 March 2016 (17.03.2016) US
- (71) Applicant: SILVERGENS, INC. [US/US]; 22222 Sherman Way, Suite #104, Canoga Park, CA 91303 (US).
- (72) Inventors: GARCIA, Cesar, Manuel; 9225 Collins Avenue, Apartment 606, Surfside, FL 33154 (US). WANDERS, Bart, Jan; 10 Woodbridge Court, Trabuco Canyon, CA 92679 (US). ALEI, Philip, Eugene; 7920 Via Ensenada, Carlsbad, CA 92008 (US). DIAZ, Conrado, Orlando; 113 Camino Ruiz, Unit 50, Camarillo, CA 93012 (US).
- (74) Agent: HANKIN, Marc, E.; Hankin Patent Law, APC, 12400 Wilshire Boulevard, Suite 1265, Los Angeles, CA 90025 (US).

- (81) Designated States (unless otherwise indicated, for every kind of national protection available): AE, AG, AL, AM, AO, AT, AU, AZ, BA, BB, BG, BH, BN, BR, BW, BY, BZ, CA, CH, CL, CN, CO, CR, CU, CZ, DE, DJ, DK, DM, DO, DZ, EC, EE, EG, ES, FI, GB, GD, GE, GH, GM, GT, HN, HR, HU, ID, IL, IN, IR, IS, JP, KE, KG, KH, KN, KP, KR, KW, KZ, LA, LC, LK, LR, LS, LU, LY, MA, MD, ME, MG, MK, MN, MW, MX, MY, MZ, NA, NG, NI, NO, NZ, OM, PA, PE, PG, PH, PL, PT, QA, RO, RS, RU, RW, SA, SC, SD, SE, SG, SK, SL, SM, ST, SV, SY, TH, TJ, TM, TN, TR, TT, TZ, UA, UG, US, UZ, VC, VN, ZA, ZM, ZW.
- (84) Designated States (unless otherwise indicated, for every kind of regional protection available): ARIPO (BW, GH, GM, KE, LR, LS, MW, MZ, NA, RW, SD, SL, ST, SZ, TZ, UG, ZM, ZW), Eurasian (AM, AZ, BY, KG, KZ, RU, TJ, TM), European (AL, AT, BE, BG, CH, CY, CZ, DE, DK, EE, ES, FI, FR, GB, GR, HR, HU, IE, IS, IT, LT, LU, LV, MC, MK, MT, NL, NO, PL, PT, RO, RS, SE, SI, SK, SM, TR), OAPI (BF, BJ, CF, CG, CI, CM, GA, GN, GQ, GW, KM, ML, MR, NE, SN, TD, TG).

Declarations under Rule 4.17:

- as to applicant's entitlement to apply for and be granted a patent (Rule 4.17(ii))
- as to the applicant's entitlement to claim the priority of the earlier application (Rule 4.17(iii))

[Continued on next page]

(54) Title: AUTOMATED MEDICATION ADHERENCE SYSTEM

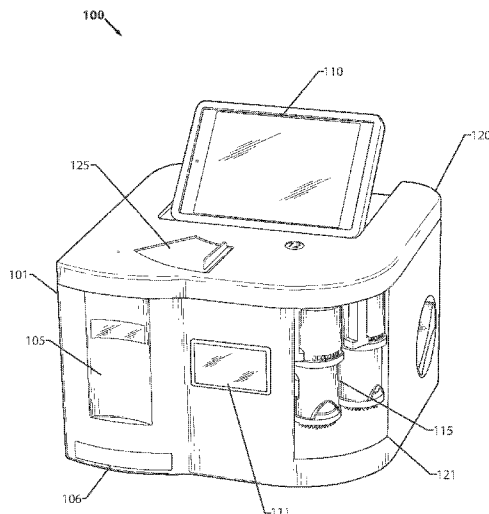

Fig.1

(57) Abstract: An automated medication adherence system. The automated medication adherence system may comprise: a housing, an electronic interface, a plurality of reservoirs, one or more sensors, and at least one pill delivery and lock-out module. The electronic interface is programmable to accept data relating to a medication, including at least one of a pill identify, a user identity, a dosage schedule, and a side effect. The electronic interface actuates rotation of a reservoir, which is configured to receive, store, and dispense pills, tablets, and capsules of various sizes accurately and precisely. The sensors monitor medication input and output, and alerts a user when medication has been dispensed and needs to be taken.

WO 2017/160525 A1

— *of inventorship (Rule 4.17(iv))*

Published:

— *with international search report (Art. 21(3))*

AUTOMATED MEDICATION ADHERENCE SYSTEM

FIELD OF USE

[0001] The present disclosure relates generally to the field of article dispensing, and more specifically, to an automated medication adherence system for use in user's home.

BACKGROUND

[0002] In 2010, there were 15.4 million Medicare beneficiaries over the age of 65 with four or more chronic conditions, of which 43% were hospitalized at least once during the year. Further, an estimated 39% of the elderly population has some type of disability (i.e., difficulty in hearing, vision, cognition, ambulation, self-care, or independent living). For a considerable number of individuals, these types of disabilities may make it difficult to adhere to a medication schedule.

[0003] Many of these individuals may depend on untrained volunteers, family, or friends to help them manage their medications. Current estimates state there are 34.2 million Americans that have provided unpaid care to an adult 50 years old or over. Approximately a quarter of these caregivers provide 41 or more hours of care per week, typically for a close relative who has been hospitalized in the past year. These caregivers often experience stress, physical and financial strain, and adverse impacts on their health while they perform complex medical and nursing responsibilities.

[0004] Furthermore, the U.S. Census Bureau anticipates population growth of 60% for the age group over 65 years old and a population decline of 1% in the age group 45 to 64 years old between 2014 and 2030. This major demographic shift may significantly affect the support system for the elderly. Even individuals that receive assistance from a paid home health aide may still have issues managing their medications, as the majority of home health aides do not administer medication or provide assistance with self-administration of medications. Many of these home health aides are prohibited to administer medication by state law, or have not obtained the required medication technician certification required by most nurse delegation programs due to cost and potential liability concerns.

[0005] Even though the elderly currently comprise only 12% of the population, they consume 33% of all prescription drugs with two out of five Medicare beneficiaries taking five or more prescription medications. The large number of medications prescribed to the elderly and chronically ill, combined with the cognitive and sometimes physical challenges of following multiple medication regimens, reduce a patient's ability to fully benefit from prescribed medications. It has been estimated that 20-30% of medication prescriptions are never filled and

50% of the time medication is not continued and completed as prescribed. Polypharmacy, defined as taking multiple medications concurrently to treat coexisting diseases, with the elderly typically leads to medication non-adherence and is estimated to occur among 25% - 75% of elderly patients, with the rate of occurrence increasing in proportion to the number of drugs and daily dosages prescribed. Lack of medication adherence can result in disease progression, death and higher costs to the healthcare system. Furthermore, non-adherence was estimated to account for 10% of hospital admissions and 23% of nursing home admissions. The New England Healthcare Institute calculates non-adherence along with suboptimal prescribing, drug administration and diagnosis could result in up to \$290 billion in losses annually in the US. Additionally, estimates report the effect of poor medication adherence results in approximately 125,000 deaths in the US annually.

[0006] There are a growing number of studies that have documented net savings associated with higher medication adherence across a range of common chronic conditions. One study demonstrated improved medication adherence might provide a net economic return for certain chronic conditions, including diabetes, hypertension, hypercholesterolemia and congestive heart failure. Consequently, the study noted increased adherence to drug therapy reduced a patient's need for medical services, including hospitalizations and emergency room visits.

[0007] However, independent management of drug administration is a relatively ineffective way to increase medication adherence. Seven-day pillboxes are probably the most common products used, but they require manual sorting of pills on a weekly basis. This is an unreliable and cumbersome process that sometimes requires assistance from a caregiver or pharmacist. One study noted that the majority of elderly patients may be unable to open and access their medications from multi-compartment pillboxes with ease, and cognitively impaired patients may experience even more difficulties than others. Forgetfulness is a major factor contributing to non-adherence, with an estimated 30% of patients with chronic conditions asserting forgetfulness. This poses a further challenge to independent seniors, which are at a higher risk of forgetting to take their medication if they experience increased busyness. However, most pillboxes do not provide interactive reminders or instructions, and are thus inadequate solutions in this respect. Another downside to pillboxes is that they may promote cross-contamination, as different pills are placed inside a small compartment together.

[0008] Smart phone applications have been developed to assist in medication adherence through reminders and alerts, but are not comprehensive solutions addressing the specific needs for patients

with several chronic conditions and potentially suffering from physical and cognitive impairments. As a result, reminders and alarms alone are not likely to improve adherence unless they are designed to provide relevant information with interactive features to facilitate addressing these concerns on a timely basis. Lastly, there are mail order pharmacies that specialize in pre-sorting prescription pills into pill pouches or blister packs and shipping directly to patients. However, the process of managing medication changes is cumbersome and apt to wasting a supply of medication. Although the pre-sorted packets help to simplify the medication administration, this is clearly not an interactive system with real-time capability to remind, instruct, monitor, and alert the status of the patient's medication adherence record.

[0009] Currently, there are no medication adherence solutions on the market that are comprehensive, fully automated, and requires no programming by the user. In addition, critical information such as medication formularies, e-prescriptions and pharmaceutical databases are kept in "silos" and are not readily available in an integrated fashion, making it difficult to retrieve data for contextual analysis. Consequently, even the more advanced medication administration products on the market still require manual pill sorting and programming of alarms and reminders – a challenging task for this at-risk population.

[0010] Accordingly, there exists a need for a device that provides an effective solution for both patients and health care providers regarding the patient's adherence or compliance with complicated medication regimens. In particular, there exists a need for an automated medication adherence system to help organize the dispensing of many different sizes and shapes of pills and capable of managing a schedule of different pills to be taken at different scheduled times. Such a system should enhance the interaction between the patient and health care provider by allowing the health care provider to be alerted when the patient is not taking the medication according to the medication schedule.

SUMMARY

[0011] To minimize the limitations in the cited references, and to minimize other limitations that will become apparent upon reading and understanding the present specification, the present specification discloses a new and improved automated medication adherence system.

[0012] One embodiment may be an automated medication adherence system, comprising a housing and an electronic interface. The electronic interface may use such data to automatically program the control logic for operating the electromechanical operation of the adherence system

and the medication dispensing and scheduling functions using information from pharmacy prescription records, pharmaceutical databases and medical professionals. The electronic interface acquires data to schedule, alert and record therapies for pill and non-pill medications. The housing may comprise a medication dispensing and lock-out module. The housing may be configured to contain a plurality of reservoirs wherein the plurality of reservoirs may be configured for receiving, storing, and dispensing one or more medications. The housing may comprise an access cover configured to have closed and opened position. The plurality of reservoirs may be accessible when the access cover is in the opened position. The access cover may comprise a pill loading assembly wherein the pill loading assembly may be configured to allow one or more medications to be loaded into at least one of the plurality of reservoirs. The electronic interface may comprise a computing component and multiple display components. The electronic interface may be on an exterior portion of the housing. The electronic interface may be programmable, such that the electronic interface accepts data relating to one or more medications from pharmacies, medical professionals, database companies and other authorized users. Each of the plurality of reservoirs may be configured to receive, store and dispense a homogenous type of medication from the one or more medications. Each of the plurality of reservoirs may comprise one or more sensors and two successive stages, a first stage and a second stage. The one or more medications may be moved from the first stage to the second stage and then from the second stage to the pill delivery and lock-out module. The one or more medications may be a plurality of pills. The one or more sensors may be configured to determine when a single pill of the plurality of pills passes through each of the two successive stages and may control pill ejection from stage 1 or 2, as appropriate. The automated medication adherence system may further comprise a rotating carrier configured to engage with the plurality of reservoirs, such that the plurality of reservoirs may be configured to rotate within the housing. The electronic interface may rotate the plurality of reservoirs in response to the data relating to the one or more medications. The data relating to the one or more medications may be selected from the group of data gathered or created through manipulation of data from prescription records, pharmaceutical databases and proprietary data bases consisting of information such as: a pill identity; a user identity; a dosage schedule; medication format (pill or non-pill; such as inhalers, solutions, creams, etc.), pill images, pharmaceutical indications for use, instructions (directions) for use, physical and chemical description of the medications, refills, side effect information and other information customarily

used to manage and administer medications. The two successive stages may be configured to be stacked, such that the first stage may be substantially above the second stage. Each of the two successive stages may comprise an opening, such that there are two openings, a first opening and a second opening. The first opening and the second opening may be selectively openable and closable in response to the electronic interface. Each of the two successive stages may receive and dispense the one or more medications through the two openings. Each of the plurality of reservoirs may comprise a central agitation stalk, an outer wall; an inner wall; optionally one or more actuators and sensors. The central agitation stalk may be configured to be substantially contained within the inner wall, and the inner wall may be configured to be substantially contained within the outer wall. The central agitation stalk may be configured to be rotatable within the inner wall. The central agitation stalk may comprise a fin portion, a wave surface, and a ribbed cone surface. The fin portion may comprise a plurality of fins that may be configured to prevent the one or more medications from clumping together. The wave surface may be a base of the first stage; and the ribbed cone surface may be a base of the second stage. The ribbed cone may have ribs, undercuts, channels or any type of texture or geometry suitably to transport the pills to the stage 2 opening. A combination of wave surface and the ribbed cone can be used at both stage 1 and stage 2. The one or more actuators may be configured to rotate and agitate the central agitation stalk and at least one of the inner wall and the outer wall. The outer wall may comprise one or more outer wall portholes and one or more chutes. The inner wall may comprise one or more inner wall portholes. At least one of the one or more actuators may be configured to rotate at least one of the inner wall and the outer wall, such that the inner wall and they outer wall may be rotated with respect to each other. When the inner wall and the outer wall are rotated with respect to each other, the one or more outer wall portholes and the one or more inner wall portholes may align to form the two openings that best match the solid geometry of the pill in that reservoir. The computing component may comprise one or more logic algorithms. The one or more sensors, the one or more actuators, and the one or more logic algorithms may be configured to control the inner wall, the outer wall, and the central agitation stalk to ensure that the one or more medications may be transferred, one pill at a time, from the first stage to the second stage. The one or more sensors, the one or more actuators, and the one or more logic algorithms may be configured to control the inner wall, the outer wall, and the central agitation stalk to ensure that the one or more medications may be transferred, one pill at a time, from the second stage to the pill delivery and lock-out module. The

electronic interface may alert a user when the one or more medications are dispensed, such that a dispensed medication may be created. The electronic interface may also alert a user when the one or more non-pill medications are required. The electronic interface may alert the user, one or more authorized individuals, and/or one or more health care providers when a user has not removed the dispensed medication from the pill delivery and lock-out module in accordance with the data relating to the one or more medications. The pill delivery and lock-out module may comprise three functions created by the translation of a pill transporter. The pill transporter may create a holding tray, a dispensing tray and a lock-out tray depending on the position of the pill transporter. If the pill transporter is in the neutral position, below the reservoir, it holds the pill or plurality of pills dispensed creating a holding tray. The transporter moves forward to create and form a pill dispensing tray that opens toward the user when the user is ready to take the pills. If the pills are not removed by the patient after a predetermined or calculated amount of time, or erroneously dispensed, the pill transporter may move in reverse to transfer the pills to a lock-out tray.

[0013] Another embodiment of the automated medication adherence system may comprise: a housing; an electronic interface; and a rotating carrier. The housing may comprise a pill loading assembly and a pill delivery and lock-out module. The housing may be configured to contain a plurality of reservoirs. The plurality of reservoirs may be configured for receiving, storing, and dispensing one or more medications. The rotating carrier may be configured to engage with the plurality of reservoirs, such that the plurality of reservoirs may be configured to rotate within the housing. The housing may comprise an access cover configured to have a closed and an opened position typically used for set-up and maintenance. The housing may comprise a reservoir loading door configured to have a closed and an opened position to be accessed by the end user. The plurality of reservoirs may be accessible when the access cover or the reservoir loading door are in the opened position. The reservoir loading door may comprise a reservoir loading assembly configured to allow the plurality of reservoirs to be loaded. The electronic interface may comprise a computing component and one or more display components. The user interface portion of the electronic interface may be on an exterior portion of the housing. The electronic interface may be manually programmed by the user or automatically by accepting data relating to the one or more medications, prescriptions, and prescription processes (*e.g.* refills, medication changes). The data relating to the one or more medications may be selected from the group of data from pharmacy prescription records, providers prescription records, pharmaceutical databases or proprietary

databases consisting of: a pill identity; a user identity; a dosage schedule; medication format (pill or non-pill; such as inhalers, solutions, creams, etc.), pharmaceutical indications for use, instructions (directions) for use, physical and chemical description of the medications, pill images, instruction for use, refills, side effect information and other information customarily use to manage and administer medications. The electronic interface may rotate the plurality of reservoirs in response to the data relating to the one or more medications. Pills may be loaded through the pill loading assembly. Each of the plurality of reservoirs may be configured to receive, store and dispense a homogenous type of the medication. Each of the plurality of reservoirs may comprise one or more sensors and two successive stages, a first stage and a second stage. The medication may be moved from the first stage to the second stage and then from the second stage to the pill delivery and lock-out module. The two successive stages may be configured to be stacked, such that the first stage may be substantially above the second stage. Each of the two successive stages may comprise an opening, such that there may be two openings, a first opening and a second opening. The first opening and the second opening may be selectively openable and closable in response to the electronic interface. Each of the two successive stages may receive and dispense the medication through the two openings. The medication may be a plurality of pills. The one or more sensors may be configured to determine when a single pill of the plurality of pills passes through each of the two openings and triggers the immediate closing of the opening. Each of the plurality of reservoirs may comprise a central agitation stalk, an outer wall, an inner wall, and one or more actuators. The central agitation stalk may be configured to be substantially contained within the inner wall, and wherein the inner wall may be configured to be substantially contained within the outer wall. The central agitation stalk may be configured to be rotatable within the inner wall. The central agitation stalk may comprise a fin portion, a wave surface, and a ribbed cone surface. The fin portion may comprise a plurality of fins that may be configured to prevent the medication from clumping together. The wave surface may be a base of the first stage. The ribbed cone surface may be a base of the second stage. The central agitation stalk may be configured to engage with at least one of the one or more actuators in order to be rotated. The central agitation stalk may comprise a plurality of gear teeth, which may be configured to be engaged with at least one of the one or more actuators. The one or more actuators may be configured to rotate the central agitation stalk and at least one of the inner wall and the outer wall. The one or more actuators may be configured to rotate or agitate the central agitation stalk and at least one of the inner wall and

the outer wall. The outer wall may comprise one or more outer wall portholes and one or more chutes. The inner wall may comprise one or more inner wall portholes. At least one of the one or more actuators may be configured to rotate at least one of the inner wall and the outer wall, such that the inner wall and the outer wall may be rotated with respect to each other. When the inner wall and the outer wall are rotated with respect to each other, the one or more outer wall portholes and the one or more inner wall portholes may align to form the two openings. The computing component may comprise one or more logic algorithms. The one or more sensors, the one or more actuators, and the one or more logic algorithms may be configured to control the inner wall, the outer wall, and the central agitation stalk to ensure that the medication may be transferred, one pill at a time, from the first stage to the second stage. The one or more sensors, the one or more actuators, and the one or more logic algorithms may be configured to control the inner wall, the outer wall, and the central agitation stalk to ensure that the medication may be transferred, one pill at a time, from the second stage to the pill delivery and lock-out module. The one or more logic algorithms may be configured to schedule and control the dispensing of medication according to the corresponding prescription or plurality of prescriptions and instructions for use.

[0014] Another embodiment of the medication reservoir for an automated medication adherence system may comprise two successive stages, a first stage and a second stage. The reservoir may be configured for receiving, storing, and dispensing a plurality of pills. Dispensing of the plurality of pills by the reservoir may be controlled by an electronic interface. The plurality of pills may be moved from the first stage to the second stage one pill at a time. The plurality of pills may be moved from the second stage to a pill delivery and lock-out module one pill at a time. Each of the two successive stages may comprise an opening, such that there may be two openings, a first opening and a second opening. The medication reservoir may further comprise one or more sensors wherein the one or more sensors may be configured to determine when a single pill of the plurality of pills passes through each of the two openings. The first and second openings may be selectively openable and closable in response to the electronic interface. The two successive stages may be configured to be stacked, such that the first stage may be substantially above the second stage. The reservoir may further comprise a central agitation stalk, an outer wall, an inner wall, and one or more actuators. The central agitation stalk may be configured to be substantially contained within the inner wall, and the inner wall may be configured to be substantially contained within the outer wall. The central agitation stalk may be configured to be rotatable within the inner

wall. The central agitation stalk may comprise a fin portion, a wave surface, and a ribbed cone surface. The fin portion may comprise a plurality of fins that may be configured to prevent the one or more medications from clumping together. The wave surface may be a base of the first stage and the ribbed cone surface may be a base of the second stage. The one or more actuators may be configured to rotate and agitate the central agitation stalk and at least one of the inner wall and the outer wall. The outer wall may comprise one or more outer wall portholes and one or more chutes. The inner wall may comprise one or more inner wall portholes. At least one of the one or more actuators may be configured to rotate at least one of the inner wall and the outer wall, such that the inner wall and the outer wall may be rotated with respect to each other. The inner wall and the outer wall may be rotated with respect to each other, the one or more outer wall portholes and the one or more inner wall portholes may align to form the two openings. The electronic interface may comprise one or more logic algorithms. The one or more sensors, the one or more actuators, and the one or more logic algorithms may be configured to control the inner wall, the outer wall, and the central agitation stalk to ensure that the one or more medications may be transferred, one pill at a time, from the first stage to the second stage. The one or more sensors, the one or more actuators, and the one or more logic algorithms may be configured to control the inner wall, the outer wall, and the central agitation stalk to ensure that the one or more medications may be transferred, one pill at a time, from the second stage to the pill delivery and lock-out module.

[0015] It is an object to provide an automated medication adherence system to schedule medication dosage, medication replenishment, medication stoppage, and treatment changeovers with minimal user intervention.

[0016] It is an object to provide an automated medication adherence system with the ability to dispense a prescribed medication with an accuracy of up to 1:100,000.

[0017] It is an object to provide an automated medication adherence system to safely manage frequent changes in medication treatment and many different sizes of pills.

[0018] It is an object to provide an automated medication adherence system to provide error-free medication loading by a patient with potential physical and cognitive limitations.

[0019] It is an object to provide an automated medication adherence system with mechanical pill handling that does not affect the integrity of the medication.

[0020] It is an object to provide an automated medication adherence system capable of acquiring

and communicating prescription instructions.

[0021] It is an object to provide ease of use by enabling a system that uses a single type of reservoir that can be programmed to handle pills of all sizes, solid geometries and construction methods. The reservoir can be used at any position within the rotating carrier.

[0022] It is an object to provide and record “pro re nata” (on demand or as needed) medication events to patients, if required.

[0023] It is an objective to provide maximum patient safety avoiding over-dosage or wrong dosage or wrong medication).

[0024] It is an object to overcome the limitations of the prior art.

[0025] Other features and advantages will become apparent to those skilled in the art from the following detailed description and its accompanying drawings.

BRIEF DESCRIPTION OF THE DRAWINGS

[0026] The drawings show illustrative embodiments, but do not depict all embodiments. Other embodiments may be used in addition to or instead of the illustrative embodiments. Details that may be apparent or unnecessary may be omitted for the purpose of saving space or for more effective illustrations. Some embodiments may be practiced with additional components or steps and/or without some or all components or steps provided in the illustrations. When different drawings contain the same numeral, that numeral refers to the same or similar components or steps.

[0027] **FIG. 1** is an illustration of a perspective view of one embodiment of the automated medication adherence system.

[0028] **FIG. 2** is an illustration of a perspective view of one embodiment of a central agitation stalk.

[0029] **FIG. 3** is an illustration of a cross-section view of one embodiment of a reservoir that is contained within the automated medication adherence system.

[0030] **FIG. 4** is an illustration of a perspective view of one embodiment of a reservoir that is contained within the automated medication adherence system.

[0031] **FIG. 5** is an illustration of an exploded view of one embodiment of a reservoir that is contained within the automated medication adherence system.

[0032] **FIG. 6** is an illustration of a cross-section view of one embodiment of the interior of the automated medication adherence system and shows the sensors and actuators.

[0033] **FIG. 7** is an illustration of a close-up view of one embodiment of the second stage of a

reservoir that is contained within the automated medication adherence system.

[0034] **FIG. 8** is an illustration of a close-up view of one embodiment of a reservoir that is contained within the automated medication adherence system with continuously variable openings to best match the solid geometry of the pill loaded into a specific reservoir.

[0035] **FIG. 9** is an illustration of another embodiment of a reservoir that is contained within the automated medication adherence system.

[0036] **FIG. 10** is an illustration of another embodiment of a reservoir that is contained within the automated medication adherence system.

[0037] **FIG. 11A** is an illustration of a close-up view of one embodiment of the pill delivery and lock-out module in its neutral position that is contained within the automated medication adherence system.

[0038] **Fig. 11B** is an illustration of a close-up view of one embodiment of the pill delivery and lock-out module in its forward position that is contained within the automated medication adherence system.

[0039] **FIG. 11C** is an illustration of one embodiment of the pill delivery and lock-out module in its reverse (lock-out tray) position that is contained within the automated medication adherence system.

[0040] **FIG. 12** is an illustration of one embodiment of the reservoir cover mechanism that opens and closes a reservoir fill opening that is contained within the automated medication adherence system.

[0041] **FIG. 13** is an illustration of one embodiment of the reservoir loading door and the pill loading assembly that are contained within the automated medication adherence system.

[0042] **FIG. 14** is a flow block diagram of one embodiment of the method of medication moving through the first stage of the automated medication adherence system.

[0043] **FIG. 15** is a flow block diagram of one embodiment of the method of medication moving through Stage 2 of the automated medication adherence system.

[0044] **FIG. 16** is a flow block diagram of one embodiment of the method of taking medication on an as-needed or away from home basis.

[0045] **FIG. 17** is a flow block diagram of one embodiment of the method of programming the reservoirs and dispense logic using one or more algorithms using the computing component.

DETAILED DESCRIPTION OF ILLUSTRATIVE EMBODIMENTS

[0046] In the following detailed description of various embodiments, numerous specific details are set forth in order to provide a thorough understanding of various aspects of the embodiments. However, the embodiments may be practiced without some or all of these specific details. In other instances, well-known procedures and/or components have not been described in detail so as not to unnecessarily obscure aspects of the embodiments.

[0047] While some embodiments are disclosed here, other embodiments will become obvious to those skilled in the art as a result of the following detailed description. These embodiments are capable of modifications of various obvious aspects, all without departing from the spirit and scope of protection. The Figures, and their detailed descriptions, are to be regarded as illustrative in nature and not restrictive. Also, the reference or non-reference to a particular embodiment shall not be interpreted to limit the scope of protection.

[0048] In the following description, certain terminology is used to describe certain features of one or more embodiments. For purposes of the specification, unless otherwise specified, the term “substantially” refers to the complete or nearly complete extent or degree of an action, characteristic, property, state, structure, item, or result. For example, in one embodiment, an object that is “substantially” located within a housing would mean that the object is either completely within a housing or nearly completely within a housing. The exact allowable degree of deviation from absolute completeness may in some cases depend on the specific context. However, generally speaking, the nearness of completion will be so as to have the same overall result as if absolute and total completion were obtained. The use of “substantially” is also equally applicable when used in a negative connotation to refer to the complete or near complete lack of an action, characteristic, property, state, structure, item, or result.

[0049] As used herein, the terms “approximately” and “about” generally refer to a deviance of within 5% of the indicated number or range of numbers. In one embodiment, the term “approximately” and “about”, may refer to a deviance of between 1-10% from the indicated number or range of numbers.

[0050] **FIG. 1** is an illustration of a perspective view of one embodiment of the automated medication adherence system. As shown in **FIG. 1**, one embodiment of the automated medication adherence system **100** may comprise: a housing **101**, a bar code reader **105**, electronic interfaces **110**, **111** a plurality of reservoirs **115**, one or more sensors (shown in **FIG. 6**), and at least one pill

delivery and lock-out module **106**. The housing **101** may be any suitable shape and size for containing one or more reservoirs **115**. For example, the housing **101** may be cubed shaped, as shown in FIG. 1. The housing **101** may define an exterior and an interior of the automated medication adherence system **100**. The exterior may comprise a bottom surface that is capable of supporting the automated medication adherence system **100** on a flat surface, such as a desk or countertop. The exterior may comprise a top access cover **120**, hereinafter referred to as an access cover, and a reservoir loading door **121** (shown in Figure 13). The access cover **120** may be movable to an open position for manually placing reservoirs **115** into the interior or removing the reservoirs **115** or to maintain the system. The access cover **120** may preferably be movable to a closed and lockable position for preventing manual access to the reservoirs **115**. Preferably, the reservoir loading door **121** may be used to load or remove reservoirs **115** by the end user. The lockable reservoir loading door **121** may be movable to an open position for manually placing or removing reservoirs **115** into the interior or removing the reservoirs **115** one at a time. Theft of prescription medicines by relatives of the prescription holder may be a problem solved by locking the access cover **120** and reservoir loading door **121**. When the access cover **120** is in a closed lockable position, a pill loading assembly **125** located on at least one portion of the access cover **120** may provide access between the exterior of the housing **101** and the interior of the housing **101** in order to load medication into the reservoirs **115**. Typically, gravity may be used to assist in loading medication through the pill loading assembly **125** into the reservoirs **115**. The interior of the housing **101** may form an interior space that is sufficiently large to completely enclose the structural components of the automated medication adherence system **100**. There may preferably be twelve reservoirs **115**, which may preferably house at least sixty (60) of the largest prescribed pills each. A movable carrier, hereinafter referred to as a rotating carrier, may hold the reservoirs **115** in position wherein the electronic interfaces **110**, **111** may actuate a motor to rotate the rotating carrier in order to align a pre-determined reservoir **115** with the pill loading assembly **125** of the access cover **120**, such that medication may travel through the pill loading assembly **125** and into the correct, known, and identified reservoir **115**. The rotating carrier may then rotate again to allow a user to load additional medications into different reservoirs **115**. Each reservoir **115** may preferably house a homogenous type of medication, but this single type of medication may be one of many different sizes or shapes. The reservoirs **115** may comprise a medication preservation system to avoid cross-contamination, such as ultraviolet light protection, dust, excessive humidity,

lids, and/or removable films. Additionally, in order to prevent contamination, a new reservoir **115** may be used each and every time a new medication is loaded and the medication may not contact or reuse any conduit except the pill loading assembly **125** of the access cover **120** and the pill delivery and lock-out module **106**.

[0051] The reservoirs **115** are preferably configured to isolate a dosage of the medication contained in the specific reservoir **115** and then automatically deliver the dosage to the pill delivery and lock-out module **106**. The dosage may be one pill or more than one pill, depending on the prescription. The system may repeat the dispensing process if multiple pills of the same type are simultaneously required. Preferably the rotating carrier rotates, such that the appropriate reservoir **115** is next to the pill delivery and lock-out module **106**. The reservoir **115** may then deliver the dosage to the pill delivery and lock-out module **106**. The rotating carrier may then rotate again, such that the next reservoir **115** may deliver a dosage of a different pill type. Once all of the dosages for that dosage time period have been delivered, the user may then take the dosage from the pill delivery and lock-out module **106**. Under certain circumstances, it may be recommendable to deliver one pill type at a time, instead of all pills scheduled at the same time. The system algorithms may be capable to handle these instructions for use.

[0052] The housing **101** of the automated medication adherence system **100** may have a pill delivery and lock-out module **106**, which may be a drawer, door, swing door, chute, and/or tray. The pill delivery and lock-out module **106** may be open or may be a locked portion, which is only unlocked for the specific user at a specific time. Once the entire dosage is in the pill delivery and lock-out module **106**, the automated medication adherence system **100** may preferably notify the user to retrieve the dosage. This notification may be an audible alert, visual alert, vibration, and/or a wireless electronic communication to an electronic device used by the user. The pill delivery and lock-out module **106** may have one or more sensors that determine the status of the dosages within the pill delivery and lock-out module **106**. The pill delivery and lock-out module **106** opens to deliver medications to user.

[0053] The pill delivery and lock-out module **106** may comprise a lock-out tray that opens in the event that a dosage is not removed from the dispensing tray configuration of the pill delivery and lock-out module **106** by the user. In this manner, the next dosage does not get mixed up with the missed dosage, avoiding an overdose. The system may record all medication events and a high frequency of pills transferred to the lock-out module may constitute a pattern of non-adherence.

Preferably, if medication non-adherence becomes an issue, a notification may be sent to the user, pharmacy, care giver and/or a health care provider. In this manner, non-adherence can be dealt with appropriately.

[0054] Although a rotating carrier is shown as the mechanism that moves the reservoirs **115** within housing **101**, the motion of the reservoirs **115** may be accomplished by other devices, including actuators, pulleys, slides, and the like.

[0055] A bar code reader **105** may be positioned on the exterior of the housing **101**, or at another appropriate location, to read the medication prescription record number and other bar-coded information needed for automatic programming and ease of use by a user of the automated medication adherence system **100**. For example, the bar code reader **105** may enable the recognition of data relating to the medication, including a pill identity, pill type, pill size, pill shape, a user identity, a dosage schedule, dosage information, and potential side effects that may be used to automatically program the automated medication adherence system. Therefore, the automated medication adherence system **100** does not require any programming by a user. Prior to loading medication into a reservoir **115**, the bar code reader **105** may allow the user to send the data relating to the medication to the electronic interface **110** for programming each of the reservoirs **115** with the specific information required to accurately dispense the medication to be loaded.

[0056] Likewise, the electronic interfaces **110, 111** may be positioned on the exterior of the housing **101**, or at another appropriate location, for ease of use by a user of the automated medication adherence system **100**. FIG. 1 shows that the electronic interfaces may be a permanent fixture and/or a removable hand held computing device. The electronic interfaces **110,111** may be used for accomplishing various interface and notification functions. For example, the electronic interface **110,111** may also be manually programmed with data relating to the medication, including a pill identity, pill type, pill size, pill shape, pill images, schedule time, daily frequency, a user identity, a dosage schedule, dosage information, not to exceed amounts, instructions for use and potential side effects. The electronic interfaces **110,111** may enable programming of each of the reservoirs **115** with the specific information about the medication to be held in the respective reservoir **115**. The electronic interface may facilitate the openings, agitation, and rotational parameters of each reservoir **115** to match the geometry, size and construction of each pill type so each reservoir **115** may be capable of accurately dispensing any pill type. The electronic interfaces **110, 111** may comprise a computing component and a display/interactive component. The

computing component may control the one or more reservoirs **115**, such that the precise dosage of medication is delivered from the reservoirs **115** to the pill delivery and lock-out module **106** each and every time on the dosage schedule. The display/interactive components may preferably be a touch screen so the patient can acknowledge and authorize certain steps, initiate certain actions, and provide a high level of interactivity and operability.

[0057] FIG. 2 is an illustration of a perspective view of one embodiment of a central agitation stalk for the reservoirs. FIG. 2 shows that each reservoir within the automated medication adherence system may comprise a central agitation stalk **200**. The central agitation stalk **200** may generally provide rotation and agitation within the reservoir, such that each reservoir may receive, store, and dispense pills, tablets, and capsules of various sizes and geometries accurately and precisely. The central agitation stalk **200** may comprise fin portion **205**, a wave surface **210**, a ribbed cone surface **215**, and gear teeth **220**. When a user loads medication into a reservoir, the fin portion **205** may prevent the medication from inadvertently clumping together. The medication may generally fall onto the wave surface **210** and be stored until the electronic interface causes the reservoir to dispense the medication. At a desired and/or scheduled time period, a drive mechanism engages with gear teeth **220** and causes the central agitation stalk **200** to rotate in order to move the medication on the wave surface **210**. This rotational movement may be combined with an agitation movement in order to move - one pill at a time - the medication from the first stage (wave surface **210**) to the lower or second stage (ribbed cone surface **215**). The medication may reside on the ribbed cone surface **215** until it is ready to be dispensed, one pill at a time, into a pill delivery and lock-out module. The fin portion **205**, wave surface **210**, and ribbed cone surface **215** may be rotated and/or agitated simultaneously, or separately, such that only one or two rotate, while the others remain still.

[0058] FIG. 3 is an illustration of a cross-section view of one embodiment of a reservoir that is contained within the automated medication adherence system. FIG. 3 shows that each reservoir **115** within the automated medication adherence system may comprise a generally cylindrical two-stage device for storing and dispensing medication. The cylindrical reservoir **115** may comprise a stalk housing **299**, also referred to as a reservoir housing, and a central agitation stalk **200**. As shown in FIG. 3, the stalk housing **299** may comprise a funnel shaped hopper **301** and two overlapping walls, outer **300** and inner wall **510**. The central agitation stalk **200**, inner wall **510**, and outer wall **300** may delineate the boundaries of the first stage **305** and the second stage **310**.

The first stage **305** may comprise a receptacle for storing medication, and then transfer the medication, in a controlled manner, to the second stage **310**. Once the reservoir **115** to be loaded with medication is aligned with the pill loading assembly in the access cover, a user may load medication via the top of the reservoir **115** into the first stage **305** of the reservoir **115**. FIG. 3 shows that the hopper **301** may be wide and funnel shaped in order to allow loading of the medication through the access cover without spilling any pills or medication and to maximize storage capacity. The medication may fall past the fin portion **205** and the central agitation stalk **200** may rotate in order for the medication to settle onto the wave surface **210**. The first stage **305** may also comprise a first opening **315** around the periphery such that the medication may exit the first stage **305** and enter the second stage **310**. Sensors, rotational and agitation actuators, and logic algorithms may ensure that only a specified number of pills, usually one or two pills, are transferred – one pill at a time – from the first stage **305** to the second stage **310**. The second stage **310** may comprise a second opening **316** for allowing the medication to be dispensed, one pill at a time, to the pill delivery and lock-out module. The first and second openings **315**, **316** may be created when openings in the inner and outer walls **510**, **300** overlap through rotational motion to create an opening that best matches the pill geometry. Proprietary algorithms may use information from the pharmacy prescription records and pharmaceutical and/or proprietary databases to calculate the reservoir **115** openings **315**, **316** and certain agitation and rotation parameters required to dispense the pills with high degree of accuracy. FIG. 3 also shows that the openings **315**, **316** may comprise or be connected to chutes **405** and **410**. As the medication pill passes through openings **315** or **316**, the chutes **405**, **410** may direct it to travel along a predetermined path.

[0059] In other embodiments, the stalk **200** housing may be of a unitary design, wherein rotational, actuation, and agitation are used to move the medication from the first stage **305** to the second stage **310** and from the second stage **310** to the pill delivery and lock-out module.

[0060] FIG. 4 is an illustration of a perspective view of one embodiment of a reservoir that is contained within the automated medication adherence system. FIG. 4 shows that each reservoir **115** within the automated medication adherence system may comprise a hopper **301** and a generally cylindrical outer wall **300**. The hopper **301** may comprise or be connected to a top portion **400** of the reservoir **115**. The top portion **400** may be covered by a rotating reservoir cover assembly **1105** that simultaneously opens and closes all reservoirs **115**, allowing access from the

pill loading assembly to the reservoir **115** when the rotating reservoir cover assembly **401** is open and preventing contamination and allowing transportation when the rotating reservoir cover assembly **1105** is closed. Additionally, the outer wall **300** may comprise or otherwise be connected to one or more chutes **405**, **410**. The first stage **305** of the reservoir **115** may comprise a first chute **405** to help guide medication traveling from the first stage **305** to the second stage **310**. The first chute **405** may be an extension of the first opening **315**. Likewise, the second stage **310** of the reservoir **115** may comprise a second chute **410** to help guide medication being dispensed into a pill delivery and lock-out module. The second chute **410** may be an extension of the second opening **316**.

[0061] FIG. 4 also shows show the inner wall **510** may be comprised of gear teeth **511** and how the inner wall **510** may be substantially contained within the outer wall **300**, such that the inner wall **510** may be turned, via gear teeth **511**, within the outer wall **300**. As shown, the gear teeth **511** may be preferably accessible through the outer wall **300**. FIG. 4 also shows how the gear teeth **220** may be accessible through the outer wall **300**.

[0062] FIG. 4 also shows how the hopper **301** may be designed to contain and be filled with medication, which may be prevented from clumping by the rotation of the fin portion **205**.

[0063] FIG. 5 is an illustration of an exploded view of one embodiment of a reservoir that is contained within the automated medication adherence system. FIG. 5 shows that each reservoir **115** within the automated medication adherence system may comprise a multi-component receptacle. FIG. 5 shows that the reservoir **115** may comprise a central agitation stalk **200**, walls **300**, **510**, and one or more retaining rings **505**. The central agitation stalk **200** may generally provide a rotational and agitation motion such that each reservoir **115** may receive, store, and dispense medication in an extremely precise and accurate manner. The outer wall **300** and the inner wall **510** may rotate relative to each other, which in turn, may create different sizes of openings around the periphery such that medication may pass between from the first stage to the second stage or be dispensed into the pill delivery and lock-out module. The retaining rings **505** may provide support to the top and bottom portions of the outer wall **300** and assist the outer wall in containing inner wall **510**. The rings **505** may also hold the stalk vertically in place within the inner wall **510**, as shown in FIG. 6.

[0064] FIG. 6 is an illustration of a cross-section view of one embodiment of the interior of the automated medication adherence system. FIG. 6 shows that the automated medication adherence

system may comprise one or more sensors **605**, **610** and one or more actuators **601**, **602**. The sensor **605** may be configured to sense when a single pill, or a specific dosage of pills moves from the first stage **305** to the second stage **310**. The sensor **605** may be an optical sensor, preferably a camera sensor, but other types of sensors may be used. The sensor **605** may preferably be positioned to monitor movement and ejection of a pill through the first opening **315**. The sensor **610** may be configured to sense when a single pill, or a specific dosage of pills moves from the second stage **310** to the pill delivery and lock-out module. The sensor **610** may be an optical sensor, preferably a camera sensor, but other types of sensors may be used. The sensor **610** may preferably be positioned to monitor movement and ejection of a pill through the second opening **316**.

[0065] The sensors **605**, **610** are preferably connected to the computing component of electronic interface, such that the automated medication adherence system can detect when a pill has transferred to the second stage **310** or to the pill delivery and lock-out module.

[0066] FIG. 6 also shows how the actuators **601** and **602** interconnect with the inner wall **510** and the central agitation stalk **200**, respectively, through the gear teeth **511** and **220**, respectively. The actuators **601**, **602** are controlled by the computing component of the electronic interface, such that the automated medication adherence system may accurately and precisely dispense medication of almost any size or shape. The actuator **601**, as shown, may cause the inner wall **510** to rotate, such that the first and/or second opening **316** may be created and/or closed as needed to move the medication and control the ejection through the automated medication adherence system. The outer wall **300** and the inner wall **510** each may have openings that, when aligned by the rotation of the inner wall **510**, create openings **316**. The actuator **601** may also provide agitation, which may de-clump the medication, in the event that a sensor **605**, **610** detects such clumping, and/or that may cause the medication to eject through the openings **315**, **316** in a controlled manner.

[0067] The actuator **601**, as shown, may cause the wave surface **210** to rotate, such that the medication resting on the wave surface **210** is brought to the first opening. Though agitation and rotation of actuators **601** and/or **602**, the pill on the wave surface **210** may be caused to go through the first opening and down to the second stage **310**, ideally one pill at a time. The sensor **605** may then inform the computing component that a single pill has successfully been moved and the actuator **601** may then close the first opening by reversing (or continuing) the rotation of the inner wall **510**. Similarly, the actuator **602**, as shown, may cause the ribbed cone surface **215** to rotate,

such that the medication resting on the ribbed cone surface **215** may be brought to the second opening **316**. Though agitation and rotation of the actuators **602** and/or **601**, only one pill on the ribbed cone surface **215** may be caused to go through the second opening **316** and out to the pill delivery and lock-out module. The sensor **610** may then inform the computing component that the single pill has successfully been moved and the actuator **602** may then close the second opening **316** by reversing (or continuing) the rotation of the inner wall **510**. This process may be repeated until the correct dosage has been delivered from to the pill delivery and lock-out module.

[0068] FIG. 7 is an illustration of a close-up view of one embodiment of the second stage of a reservoir that is contained within the automated medication adherence system. FIG. 7 shows that the second stage **310** of a reservoir **115** may house medication on the ribbed cone surface **215** of the central agitation stalk **200** prior to dispensing the medication into the pill delivery and lock-out module. Preferably, the amount of medication on the ribbed cone surface **215** is only a small number of pills, and may be a single dosage of the medication to be delivered to the pill delivery and lock-out module. The actuator may align the outer wall **300** and the inner wall of the reservoir **115** such that the opening **316** (shown in FIG. 8) is not yet formed. Thus, the medication in the second stage **310** cannot yet exit. The ribbed cone surface **215** may be agitated by the actuator at specific amplitudes and frequencies in order to facilitate the separation of the medication on the ribbed cone surface **215**, in order to line up one pill behind the other so that the medication can be transferred, one pill at a time, to the pill delivery and lock-out module. The actuator may continue (or reverse) the rotation of the ribbed cone surface **215** until each pill conforms to its exit position, preferably lengthwise. Additionally, using pre-programmed medication data and algorithms, the rotation and agitation parameters may adjust the opening **316** to best match the dimensions of the pill.

[0069] FIG. 8 is an illustration of a close-up view of one embodiment of a reservoir that is contained within the automated medication adherence system with continuously variable openings to best match the solid geometry of the pill loaded into a specific reservoir. FIG. 8 shows that the second stage **310** of a reservoir **115** may house medication on the ribbed cone surface **215** of the central agitation stalk **200** prior to dispensing the medication into a pill delivery and lock-out module. The outer wall **300** and the inner wall **510** of the reservoir **115** may be aligned such that the second opening **316** around the periphery is formed and accessible for medication dispensing at a desired period of time. When the medication reaches the second opening **316** around the

periphery, the medication, through gravity, may pass through the second opening **316**. Agitation may be provided by the central agitation stalk **200** in order to assist the medication in passing through the second opening **316**. Algorithms for agitation and rotation parameters may be pre-programmed into the electronic interface and may include specific amplitudes and frequencies in order to facilitate the travel of the medication through the automated medication adherence system. The automated medication adherence system may accommodate medication generally ranging from about 3 to about 28 millimeters, but the reservoir size, openings, and agitation and rotation parameters may be changed to increase the range of pill sizes and solid geometries. Once the dosage of medication has been dispensed, the electronic interface may close the second opening **316** and provide an alert that the medication is available for consumption.

[0070] FIG. 9 is an illustration of another embodiment of a reservoir that is contained within the automated medication adherence system. FIG. 9 shows that the reservoir **900** may comprise two successive stages, a first stage **905** and a second stage **910**. The two successive stages may be configured to be stacked, such that the first stage **905** is substantially above the second stage **910**. A user may load medication into the first stage **905** of the reservoir **900**. A plurality of pills may move from the first stage **905** to the second stage **910** through a first opening **915**. Sensors, rotational and agitation actuators, and logic algorithms may ensure that only a specified number of pills, usually one or two pills, are transferred – preferably one pill at a time – from the first stage **905** to the second stage **910**. The second stage **910** may comprise a second opening **920** for allowing the medication to be dispensed, preferably one pill at a time, to a pill delivery and lock-out module. A baffle **921** may be positioned over the first opening **915** to prevent pills from going directly from the first stage **905** to the second stage **910** and to reduce the static pressure thereby facilitating a gradual transition of pills from the first stage **905** to the second stage **910**. FIG. 9 also shows that the openings **915**, **920** may comprise or be connected to chutes **925** and **930** and spring-loaded gates **916** and **917**. The reservoir **900** may rotate to agitate the pills and to transfer the pills from the first stage **905** to the second stage **910** and counter-rotate to transfer the pills from the second stage **910** to the pill delivery and lock-out module. During rotation of the reservoir **900**, the fixed gate opener **922** may help open the spring-loaded gate **916** in order to transfer pills from the first stage **905** to the second stage **910**. A pill detection area **923** may detect the number of pills that have transferred from the first stage **905** to the second stage **910**. During counter-rotation of the reservoir **900**, a second spring-loaded gate **917** may open in order to transfer pills

from the second stage 910 to the pill delivery and lock-out module. As the pills pass through openings 915 or 920, the chutes 925, 930 may direct them to travel along a predetermined path.

[0071] FIG. 10 is an illustration of another embodiment of a reservoir that is contained within the automated medication adherence system. FIG. 10 shows that once the reservoir 950 is aligned with the pill loading assembly in the access cover, a user may load medication into the reservoir cover assembly 955, allowing access from the pill loading assembly to the reservoir 950 when the reservoir cover assembly 955 is open and preventing contamination and allowing transportation when the reservoir cover assembly 955 is closed. Typically, gravity may be used to assist in loading medication through the reservoir cover assembly 955 into the reservoir 950. The reservoir 950 may preferably house a heterogeneous type of medication, where medication may be one of many different sizes or shapes. As shown in FIG. 10, the reservoir 950 may comprise a wheel 960. The wheel 960 may preferably comprise six (6) pill scoops 965. The end 970 of each pill scoop 965 may comprise a different geometry to conform to different pill sizes or shapes. When a pill is ready for dispensing, proprietary controlled vibration, motion, and shaking of the wheel 960 may assist the pill scoop 965 in retrieving a single pill from the plurality of pills housed in the reservoir 950. Matching the pill scoop 965 with the appropriate pill size and shape may be determined by a vision or sensor system or information stored in the pharmaceutical and/or proprietary databases. Preferably, the wheel 960 may rotate in either direction, to align the pill scoop 965 into position. Then the wheel 960 may rotate in a clockwise direction to sweep through the plurality of pills and scoop up the appropriate pill. The vision or sensor system may determine if the pill scoop 965 has (i) a single and correct pill ready for ejection, (ii) has more than one pill, or (iii) is empty. Preferably, only a single pill will be located on the end 970 of the correct arm of pill scoop 965. If more than one pill is on the pill scoop 965, the wheel 960 may shake or agitate to knock off excess pills. If the pill scoop 965 is empty, the pill scoop 965 may try to scoop up the correct pill again. The pill may exit the reservoir 950 via a spring-loaded gate 975. When the pill is ready for ejection, the wheel 960 may rotate in the counter clockwise direction slightly to allow the ejection arm (not shown) to enter to reservoir 950. Once the ejection arm has entered the reservoir 950 via the spring-loaded gate 975, the wheel 960 may rotate in the clockwise direction to bring the pill into position with the ejection arm. The ejection arm may then retract to eject a pill.

[0072] FIG. 11A is an illustration of a close-up view of one embodiment of the pill delivery and

lock-out module in its neutral (holding pill delivery and lock-out module) position that is contained within the automated medication adherence system. FIG. 11A shows that the reservoirs **115** are preferably configured to isolate a dosage of medication contained in the specific reservoir **115** and then deliver the dosage to the pill delivery and lock-out module **106**. The pill delivery and lock-out module **106** may comprise a dispensing tray **1000**, a transporter **1005**, and a lock-out tray, which is created by the axial movement of the transporter **1005** in relation to the other components described below. The pill delivery and lock-out module **106** may be substantially housed within the interior of the automated medication adherence system **100** when holding medication. Preferably, the rotating carrier **1010** rotates, such that the appropriate reservoir **115** may be next to the pill delivery and lock-out module **106**. Then an actuator may cause the reservoir **115** to rotate, such that the medication resting on the ribbed cone surface may be brought to the second opening **316**. Through agitation and rotation of the actuators, the medication on the ribbed cone surface may be caused to go through the second opening **316** and out to the pill delivery and lock-out module **106**. The dosage of medication may be one or more pills. The dosage may come from one or more reservoirs **115**. Once the entire dosage is within the dispensing tray **1000**, the user may then be signaled to collect the dosage. A sensor **610** may inform the computing component that the medication has successfully been moved and the actuator may close the second opening **316** by rotation of the inner wall of the reservoir **115**. This process may be repeated until the correct dosage of medication(s) has been delivered to the pill delivery and lock-out module **106**. The sensor **610** may preferably be positioned to monitor movement of medication through the second opening **316** to the pill delivery and lock-out module **106**. The sensor **610** may take pictures and store data confirming that a dosage and/or total dosage of medication was dispensed. When the prescribed dose of medication for that dosage time period has been delivered to the pill delivery and lock-out module **106**, the pill delivery and lock-out module **106** may move to the exterior of the automated medication adherence system **100** to a forward position so a user may then take the dosage of medication from the pill delivery and lock-out module **106**. Additionally, notification may alert a user the medication is ready for consumption.

[0073] FIG. 11A also shows that if one or more pills were erroneously dispensed, the pill delivery and lock-out module **106** may remain in the neutral position, below the reservoir **115**, and hold the pills that were dispensed from the second opening **316**. The transporter **1005** may also move in reverse to transfer any erroneously dispensed pills to a lock-out tray **1015** (shown in FIG. 11C).

Preferably, when the lock-out tray **1015** operates, a notification may be sent to the user, any authorized individual, and/or a health care provider. In this manner, missed or incorrect dosages may be dealt with appropriately.

[0074] Fig. 11B is an illustration of a close-up view of one embodiment of the pill delivery and lock-out module in a forward position. FIG. 11B shows when one or more pills are dispensed from the second opening **316** of a reservoir **115**, the transporter **1005** may move forward to eject the dispensing tray **1000** into a forward position when the patient is ready to take the pills. If the pill delivery and lock-out module **106** is in the forward position and the pills are not removed by the patient after a period of time, the transporter **1005** may also move in reverse to transfer the pills to a lock-out tray **1015**. A dosage of medication may rest within the pill delivery and lock-out module **106** until the medication is ready to be collected by a user.

[0075] FIG. 11C is an illustration of one embodiment of the pill delivery and lock-out module in its reverse (lock-out tray) position that is contained within the automated medication adherence system. FIG. 11C shows that if a dosage of medication is not retrieved after a pre-determined period of time or if the dosage of medication has been dispensed incorrectly, the transporter **1005** may move or slide backward and guide the medication from the dispensing tray **1000** of the pill delivery and lock-out module **106** to a lock-out tray **1015**. Once the medication is stored in the lock-out tray **1015**, a user adherence record may be updated and the transporter **1005** may move back into its neutral position. In this manner, the next dosage may not get mixed up with the previous dosage, avoiding an over dosage, and an incorrect dosage may be held in the lock-out tray **1015**. Preferably, when the lock-out tray **1015** operates, a notification may be sent to the user, one or more authorized individuals, and/or one or more health care providers. In this manner, missed or incorrect dosages may be dealt with safely and appropriately and double or wrong dosage is prevented. FIG. 11C shows that actuator **1020** may be used to slide the transporter **1005** back and forth to dispense or retrieve an unused or incorrect dosage.

[0076] FIG. 12 is an illustration of one embodiment of the reservoir cover mechanism that opens and closes a reservoir fill opening that is contained within the automated medication adherence system. FIG. 12 shows the automated medication adherence system **100** may comprise an access cover. The access cover may be movable to an open or closed position. When the access cover is in a closed lockable position, a pill loading assembly located on at least one portion of the top access cover may provide access between the exterior of the housing and the interior of the housing

in order to load medication into the reservoirs **115**. A rotating carrier **1010**, may hold the reservoirs **115** in position wherein the electronic interface may actuate a motor to rotate the rotating carrier **1010** in order to align a pre-determined reservoir **115** with the pill loading assembly of the access cover, such that medication may travel through the pill loading assembly and into the correct, known, and identified reservoir **115**. The rotating carrier **1010** may then rotate again to allow a user to load additional medications into different reservoirs **115**. The interior of the housing may also comprise a rotary lid **1105**. The rotary lid **1105** may be positioned above the reservoirs **115** and may passively rotate in response to the clockwise or counter clockwise rotation of the rotating carrier **1010**. The rotary lid **1105** may provide access to the interior of the reservoirs **115** when the openings **1110** in the rotary lid **1105** align with the openings of the rotating reservoir cover assembly **401**. Likewise, the rotary lid **1105** may prevent access to the interior of the reservoirs **115** when the openings **1110** in the rotary lid **1105** do not align with the openings of the rotating reservoir cover assembly **401**. An additional fixed cover may be present above the rotary lid **1105**. [0077] FIG. 13 is an illustration of one embodiment of the automated medication adherence system showing the reservoir loading door and the pill loading assembly. Fig. 13 shows the reservoir loading door **121** may be used to load or remove reservoirs **115** by the end user. The reservoir loading door **121** may be movable to an open position **1200** for manually placing or removing reservoirs **115** into the interior of the automated medication adherence system **100** or removing the reservoirs **115** one at a time. Preferably, the reservoir loading door **121** may slide individual reservoirs **115** in and/or out of the interior of the automated medication adherence system **100**. When the reservoir loading door **121** is not in use, the reservoir loading door **121** may fold up in a vertical direction and form part of the exterior of the housing **101**.

[0078] Fig. 13 also shows when the access cover **120** is in a closed lockable position, a pill loading assembly **125** located on at least one portion of the access cover **120** may provide access between the exterior of the housing **101** and the interior of the housing **101** in order to load medication into the reservoirs **115**. Typically, gravity may be used to assist in loading medication through the pill loading assembly **125** into the reservoirs **115**. The pill loading assembly **125** may also comprise a pill wiper **1205**, which may wipe medication into the reservoirs **115**. When the pill loading assembly **125** is not in use, the pill wiper **1205** may remain in a closed position, preventing access to the pill loading assembly **125**.

[0079] FIG. 14 is a flow block diagram of one embodiment of the method of medication moving

through the first stage of the automated medication adherence system **1300**. FIG. 14 shows that after a user loads medication into the automated medication adherence system, the medication may remain in the first stage **1305** of the reservoir for storage until the medication is ready to be transferred to the second stage. The agitator may agitate the reservoir using proprietary algorithms at set time intervals in order to prevent the medication from sticking to one another **1310**. Similarly, the reservoir may agitate using calculated algorithms to begin transporting the medication toward the opening in the first stage using calculated rotation and counter rotation parameters. Preferably, the agitator may be optimized for a particular pill size and shape **1315**. Accordingly, the opening in the first stage may start opening based on the medication's dimensions **1320**. The opening may increase from a minimum clearance level **1325** until it has reached the maximum clearance level **1330**. If the medication has not dispensed into the second stage, the agitator may counter rotate a number of full turns **1335**. This may help the pills realign on the surface and may clear pill jams within the first stage. The sensor may detect when a single pill has been dispensed and immediately close the opening in the first stage. The medication should now be in stage two **1345**.

[0080] FIG. 15 is a flow block diagram of one embodiment of the method of medication moving through the second stage of the automated medication adherence system **1400**. FIG. 15 shows that after that the medication may travel from the first stage to the second stage **1405**. Once the medication is in the second stage, the agitator may rotate in order to line the medication up in single line along the surface of the second stage, if more than one pill was transferred from the first stage to the second stage **1410**. The opening of the second stage may open based on the medication's dimensions **1415** and the agitator may slowly begin to rotate **1420** in order to help the medication dispense into the pill delivery and lock-out module. If the medication did not dispense, the agitator may rotate for two full turns **1425** in order to dispense the medication. A sensor may detect when a single pill has been dispensed into the pill delivery and lock-out module and the opening of the second stage may close and the agitator may stop rotating **1430**. The pills may fall out via gravity from the second stage opening as the pills are rotated past the second stage opening.

[0081] FIG. 16 is a flow block diagram of one embodiment of the method of taking medication on an as-needed or away from home basis **1500**. When a user engages with the automated medication adherence system, the automated medication adherence system may inquire as to the

user's identity and authentication **1505**. Although the automated medication adherence system does not require the user to do any programming, the user may be required to input, scan, or otherwise upload information relating to the user, the medication, the prescribing entity, and/or the prescription. If a user would like to use the automated medication adherence system for on demand medication **1510**, the user may be directed to the Main Menu of the computing component **1515**. Otherwise, the user may select a medication event such as an as-needed basis or away from home basis **1520**. If the user decides to take the medication on an as-needed basis, the user may be prompted to select a pill type **1525**. The medication may then undergo a special dispensing routine **1545**. The automated medication adherence system may then dispense the medication and a user may remove the medication for consumption **1555**. If the user has exceeded the maximum number of on-demand medications allowed over a pre-determined period of time, the system may not dispense anymore medication and may alert the user and a medical professional of this condition. If the user decides to take the medication on an away from home basis, the user may have to decide whether they will be away from home for more than one day **1530**. If the user may be away from home for more than one day, the user may enter the number of days they will be away from home **1538**. If the user will not be away from home for more than one day, the user may specify when they will be away, for example, in the morning and/or the evening **1535**. The automated medication adherence system may then calculate the type and number of pills required by the user **1540**. The medication may then undergo a special dispensing routine **1545**. The automated medication adherence system may then dispense the medication and a user may remove the medication for consumption **1555**.

[0082] FIG. 17 is a flow block diagram of one embodiment of the method of programming the reservoirs and dispense logic using one or more algorithms using the computing component **1600**. FIG. 17 shows the user information and data relating to the medication may be transmitted to and from an automated medication adherence system **1610**, by one or more health care providers **1615**, and/or pharmacists **1620** through an online connection, bar code scan, or direct upload. For example, the electronic interface **1625** may be manually programmed with data relating to the medication, including a pill identity, pill type, pill size, pill shape, pill images, schedule time, daily frequency, a user identity, a dosage schedule, dosage information, not to exceed amounts, instructions for use and potential side effects. The electronic interface **1625** may enable programming of each of the reservoirs with the specific information about the medication to be

held in the respective reservoir. Additionally, the electronic interface may utilize a bar code reader, positioned on the exterior of the automated medication adherence system **1610**, or at another appropriate location, to read the medication prescription record number and other bar-coded information needed for automatic programming and ease of use by a user **1605** of the automated medication adherence system **1610**. For example, the bar code reader may enable the recognition of data relating to the medication, including a pill identity, pill type, pill size, pill shape, a user identity, a dosage schedule, dosage information, and potential side effects. Therefore, the automated medication adherence system **1610** does not require any programming by a user **1605**. Prior to loading medication into a reservoir, the bar code reader may allow the user **1605** to send data relating to the medication to the electronic interface **1625** for programming each of the reservoirs with specific information about the medication to be loaded.

[0083] The data relating to the medication may be stored in a cloud application **1630**. The cloud application **1630** may also receive data relating to the medication from a pharmacy software interface **1635**. When a health care provider **1615** writes a prescription for the user **1605**, the prescription may be stored in a health care provider software interface **1640** and transmitted as an e-prescription **1645** to the pharmacy software interface **1635**. The pharmacy software interface **1635** may work in conjunction with a pharmacist **1620** to dispatch the appropriate medication for the user **1605**. Additionally, the pharmacy software interface **1635** may transmit the e-prescription **1645** to the cloud application **1630** for programming the electronic interface **1625** of the automated medical adherence system **1610**. Data relating to the medication may also be stored in a medication database **1655**.

[0084] FIG. 17 also shows that the automated medication adherence system **1610** may be in communication with a health care provider **1615** to allow the health care provider **1615** to perform various modifications to the programming of the automated medication adherence system **1610** from a remote location. Additionally, this communication may alert a health care provider **1615** to problems, such as when the user **1605** fails to remove one or more dosages of medication from the pill delivery and lock-out module. Communication is preferably achieved by sending and receiving medication events **1650** via a cloud application **1630**.

[0085] Unless otherwise stated, all measurements, values, ratings, positions, magnitudes, sizes, locations, and other specifications that are set forth in this specification, including in the claims that follow, are approximate, not exact. They are intended to have a reasonable range that is

consistent with the functions to which they relate and with what is customary in the art to which they pertain.

[0086] The foregoing description of the preferred embodiment has been presented for the purposes of illustration and description. While multiple embodiments are disclosed, still other embodiments will become apparent to those skilled in the art from the above detailed description. The disclosed embodiments capable of modifications in various obvious aspects, all without departing from the spirit and scope of the protection. Accordingly, the detailed description is to be regarded as illustrative in nature and not restrictive. Also, although not explicitly recited, one or more embodiments may be practiced in combination or conjunction with one another. Furthermore, the reference or non-reference to a particular embodiment shall not be interpreted to limit the scope. It is intended that the scope or protection not be limited by this detailed description, but by the claims and the equivalents to the claims that are appended hereto.

[0087] Unless otherwise stated, all measurements, values, ratings, positions, magnitudes, sizes, locations, and other specifications that are set forth in this specification, including in the claims that follow, are approximate, not exact. They are intended to have a reasonable range that is consistent with the functions to which they relate and with what is customary in the art to which they pertain.

[0088] The foregoing description of the preferred embodiment has been presented for the purposes of illustration and description. While multiple embodiments are disclosed, still other embodiments will become apparent to those skilled in the art from the above detailed description. These embodiments are capable of modifications in various obvious aspects, all without departing from the spirit and scope of protection. Accordingly, the detailed description is to be regarded as illustrative in nature and not restrictive. Also, although not explicitly recited, one or more embodiments may be practiced in combination or conjunction with one another. Furthermore, the reference or non-reference to a particular embodiment shall not be interpreted to limit the scope of protection. It is intended that the scope of protection not be limited by this detailed description, but by the claims and the equivalents to the claims that are appended hereto.

[0089] Except as stated immediately above, nothing that has been stated or illustrated is intended or should be interpreted to cause a dedication of any component, step, feature, object, benefit, advantage, or equivalent, to the public, regardless of whether it is or is not recited in the claims.

CLAIMS

What is claimed is:

1. An automated medication adherence system, comprising:
 - a housing;
 - an electronic interface; and
 - one or more of sensors;
 - wherein said housing comprises a pill delivery and lock-out module;
 - wherein said housing is configured to contain a plurality of reservoirs;
 - wherein said plurality of reservoirs are configured for receiving, storing, and dispensing one or more medications;
 - wherein said housing comprises an access cover;
 - wherein said housing comprises a reservoir loading door;
 - wherein said access cover comprises a pill loading assembly;
 - wherein said pill loading assembly is configured to allow said one or more medications to be loaded into at least one of said plurality of reservoirs;
 - wherein said reservoir loading door comprises a reservoir loading assembly;
 - wherein said reservoir loading door is configured to allow said one or more reservoirs to be loaded and locked into a rotating carrier;
 - wherein said electronic interface comprises a computing component and at least one display component;
 - wherein said electronic interface is on an exterior portion of said housing;
 - wherein said electronic interface is programmable, such that said electronic interface accepts data relating to said one or more medications;
 - wherein each of said plurality of reservoirs is configured to receive, store and dispense a homogenous type of medication of said one or more medications;
 - wherein each of said plurality of reservoirs comprises two successive stages, a first stage and a second stage;
 - wherein said one or more medications are moved from said first stage to said second stage and then from said second stage to said pill delivery and lock-out module;
 - wherein said one or more medications are a plurality of pills; and

- wherein each of one or more sensors are connected with said computing component;
wherein said one or more sensors are configured to determine when a single pill of
said plurality of pills passes through each of said two successive stages.
2. The automated medication adherence system of claim 1, further comprising:
a rotating carrier;
wherein said rotating carrier is configured to engage with said plurality of reservoirs,
such that said plurality of reservoirs are configured to rotate within said
housing.
 3. The automated medication adherence system of claim 2, wherein said electronic
interface rotates said plurality of reservoirs in response to said data relating to said
one or more medications.
 4. The automated medication adherence system of claim 1, wherein said data relating to
said one or more medications is selected from the group of data consisting of: a pill
identity; a user identity; a dosage schedule; a medication format; a pill image; a
plurality of pharmaceutical indications for use; instructions for use; a physical
description; a chemical description; a refill information; and a plurality of side effect
information.
 5. The automated medication adherence system of claim 1, wherein said two successive
stages are configured to be stacked, such that said first stage is substantially above
said second stage;
wherein each of said two successive stages comprises an opening, such that there are
two openings, a first opening and a second opening.
 6. The automated medication adherence system of claim 5, wherein said first opening
and said second opening are selectively openable and closable in response to said
electronic interface;
wherein each of said two successive stages receive and dispense said one or more
medications through said two openings.
 7. The automated medication adherence system of claim 6, wherein each of said
plurality of reservoirs comprises a central agitation stalk, an outer wall; an inner wall;
and one or more actuators;

- wherein said central agitation stalk is configured to be substantially contained within said inner wall, and wherein said inner wall is configured to be substantially contained within said outer wall; and
- wherein said central agitation stalk is configured to be rotatable within said inner wall.
8. The automated medication adherence system of claim 7, wherein said central agitation stalk comprises a fin portion, a wave surface, and a ribbed cone surface; wherein said fin portion comprises a plurality of fins that are configured to prevent said one or more medications from clumping together; wherein said wave surface is a base of said first stage; and wherein said ribbed cone surface is a base of said second stage.
9. The automated medication adherence system of claim 8, wherein said one or more actuators are configured to rotate and agitate said central agitation stalk and at least one of said inner wall and said outer wall.
10. The automated medication adherence system of claim 9, wherein said outer wall comprises one or more outer wall portholes and one or more chutes; wherein said inner wall comprises one or more inner wall portholes; wherein at least one of said one or more actuators is configured to rotate at least one of said inner wall and said outer wall, such that said inner wall and said outer wall are rotated with respect to each other; wherein when said inner wall and said outer wall are rotated with respect to each other, said one or more outer wall portholes and said one or more inner wall portholes align to form said two openings; wherein said computing component comprises one or more logic algorithms; wherein said one or more sensors, said one or more actuators, and said one or more logic algorithms are configured to control said inner wall, said outer wall, and said central agitation stalk to ensure that said one or more medications are transferred, one pill at a time, from said first stage to said second stage; and wherein said one or more sensors, said one or more actuators, and said one or more logic algorithms are configured to control said inner wall, said outer wall, and said central agitation stalk to ensure that said one or more medications are

transferred, one pill at a time, from said second stage to said pill delivery and lock-out module.

11. The automated medication adherence system of claim 10, wherein said electronic interface alerts a user when said one or more medications are dispensed, such that a dispensed medication is created.
12. The automated medication adherence system of claim 11, wherein said electronic interface alerts one or more of said user, one or more authorized individuals, and one or more health care providers when said user has not removed said dispensed medication from said pill delivery and lock-out module in accordance with said data relating to said one or more medications.
13. The automated medication adherence system of claim 12, wherein said pill delivery and lock-out module comprises a holding tray, a dispensing tray, and a lock-out module;
wherein said lock-out module opens and accepts said dispensed medication not removed from said pill delivery and lock-out module or dispensed medication that was incorrectly dispensed;
wherein said access cover is configured to have closed and opened positions; and
wherein said plurality of reservoirs are accessible when said access cover is in said opened position for purposes of maintenance.
14. An automated medication adherence system, comprising:
a housing;
an electronic interface;
a rotating carrier;
wherein said housing comprises a pill delivery and lock-out module;
wherein said housing is configured to contain a plurality of reservoirs;
wherein said plurality of reservoirs are configured for receiving, storing, and dispensing one or more medications;
wherein said rotating carrier is configured to engage with said plurality of reservoirs, such that said plurality of reservoirs are configured to rotate within said housing;
wherein said housing comprises an access cover;

wherein said housing comprises a reservoir loading door;
wherein said access cover is configured to have closed and opened positions;
wherein said plurality of reservoirs are accessible when said access cover is in said opened position;
wherein said access cover comprises a pill loading assembly;
wherein said pill loading assembly is configured to allow said one or more medications to be loaded into at least one of said plurality of reservoirs;
wherein said reservoir loading door comprises a reservoir loading assembly;
wherein said reservoir loading door is configured to allow said one or more reservoirs to be loaded and locked into a rotating carrier;
wherein said electronic interface comprises a computing component and at least one display component;
wherein said electronic interface is on an exterior portion of said housing;
wherein said electronic interface is programmable, such that said electronic interface accepts data relating to said one or more medications;
wherein said data relating to said one or more medications is selected from the group of data consisting of: a pill identity; a user identity; a dosage schedule; a medication format; a pill image; a plurality of pharmaceutical indications for use; instructions for use; a physical description; a chemical description; a refill information; and a plurality of side effect information;
wherein said electronic interface rotates said plurality of reservoirs in response to said data relating to said one or more medications;
wherein each of said plurality of reservoirs is configured to receive, store and dispense a homogenous type of said medication;
wherein each of said plurality of reservoirs comprises one or more sensors and two successive stages, a first stage and a second stage;
wherein said medication is moved from said first stage to said second stage and then from said second stage to said pill delivery and lock-out module;
wherein said two successive stages are configured to be stacked, such that said first stage is substantially above said second stage;

wherein each of said two successive stages comprises an opening, such that there are two openings, a first opening and a second opening;

wherein said first opening and said second opening are selectively openable and closable in response to said electronic interface;

wherein each of said two successive stages receives and dispenses said medication through said two openings;

wherein said medication is a plurality of pills;

wherein said one or more sensors are configured to determine when a single pill of said plurality of pills passes through each of said two openings;

wherein each of said plurality of reservoirs comprises a central agitation stalk, an outer wall, an inner wall, and one or more actuators;

wherein said central agitation stalk is configured to be substantially contained within said inner wall, and wherein said inner wall is configured to be substantially contained within said outer wall;

wherein said central agitation stalk is configured to be rotatable within said inner wall;

wherein said central agitation stalk comprises a fin portion, a wave surface, and a ribbed cone surface;

wherein said fin portion comprises a plurality of fins that are configured to prevent said medication from clumping together;

wherein said wave surface is a base of said first stage;

wherein said ribbed cone surface is a base of said second stage;

wherein said central agitation stalk is configured to engage with at least one of said one or more actuators in order to be rotated;

wherein said central agitation stalk comprises a plurality of gear teeth, which are configured to be engaged with at least one of said one or more actuators;

wherein said one or more actuators are configured to rotate said central agitation stalk and at least one of said inner wall and said outer wall;

wherein said one or more actuators are configured to agitate said central agitation stalk and at least one of said inner wall and said outer wall;

- wherein said outer wall comprises one or more outer wall portholes and one or more chutes;
- wherein said inner wall comprises one or more inner wall portholes;
- wherein at least one of said one or more actuators are configured to rotate at least one of said inner wall and said outer wall, such that said inner wall and said outer wall are rotated with respect to each other;
- wherein when said inner wall and said outer wall are rotated with respect to each other, said one or more outer wall portholes and said one or more inner wall portholes align to form said two openings;
- wherein said computing component comprises one or more logic algorithms;
- wherein said one or more sensors, said one or more actuators, and said one or more logic algorithms are configured to control said inner wall, said outer wall, and said central agitation stalk to ensure that said medication is transferred, a set number of pills at a time, from said first stage to said second stage; and
- wherein said one or more sensors, said one or more actuators, and said one or more logic algorithms are configured to control said inner wall, said outer wall, and said central agitation stalk to ensure that said medication is transferred, one pill at a time, from said second stage to said pill delivery and lock-out module.
15. A medication reservoir for an automated medication adherence system, comprising:
two successive stages, a first stage and a second stage;
wherein said reservoir is configured for receiving, storing, and dispensing a plurality of pills;
wherein dispensing of said plurality of pills by said reservoir is controlled by an electronic interface;
wherein said plurality of pills are transferred from said first stage to said second stage one pill at a time;
wherein said plurality of pills are transferred from said second stage to a pill delivery and lock-out module one pill at a time.
16. The medication reservoir of claim 15, wherein each of said two successive stages comprises an opening, such that there are two openings, a first opening and a second opening.

17. The medication reservoir of Claim 16, further comprising:
one or more sensors;
wherein said one or more sensors are configured to determine when a single pill of
said plurality of pills passes through each of said two openings.
18. The medication reservoir of claim 17, wherein said first and second openings are
selectively openable and closable in response to said electronic interface;
wherein said two successive stages are configured to be stacked, such that said first
stage is substantially above said second stage.
19. The medication reservoir of claim 18, wherein said reservoir further comprises a
central agitation stalk, an outer wall, an inner wall, and one or more actuators;
wherein said central agitation stalk is configured to be substantially contained within
said inner wall, and wherein said inner wall is configured to be substantially
contained within said outer wall; and
wherein said central agitation stalk is configured to be rotatable within said inner
wall.
20. The medication reservoir of claim 19, wherein said central agitation stalk comprises a
fin portion, a wave surface, and a ribbed cone surface;
wherein said fin portion comprises a plurality of fins that are configured to prevent
said one or more medications from clumping together;
wherein said wave surface is a base of said first stage; and
wherein said ribbed cone surface is a base of said second stage.
21. The medication reservoir of claim 20, wherein said one or more actuators are
configured to rotate and agitate said central agitation stalk and at least one of said
inner wall and said outer wall.
22. The medication reservoir of claim 21, wherein said outer wall comprises one or more
outer wall portholes and one or more chutes;
wherein said inner wall comprises one or more inner wall portholes;
wherein at least one of said one or more actuators is configured to rotate at least one
of said inner wall and said outer wall, such that said inner wall and said outer
wall are rotated with respect to each other;

wherein when said inner wall and said outer wall are rotated with respect to each other, said one or more outer wall portholes and said one or more inner wall portholes align to form said two openings;

wherein said electronic interface comprises one or more logic algorithms;

wherein said one or more sensors, said one or more actuators, and said one or more logic algorithms are configured to control said inner wall, said outer wall, and said central agitation stalk to ensure that said one or more medications are transferred, one pill at a time, from said first stage to said second stage; and

wherein said one or more sensors, said one or more actuators, and said one or more logic algorithms are configured to control said inner wall, said outer wall, and said central agitation stalk to ensure that said one or more medications are transferred, one pill at a time, from said second stage to said pill delivery and lock-out module.

1/19

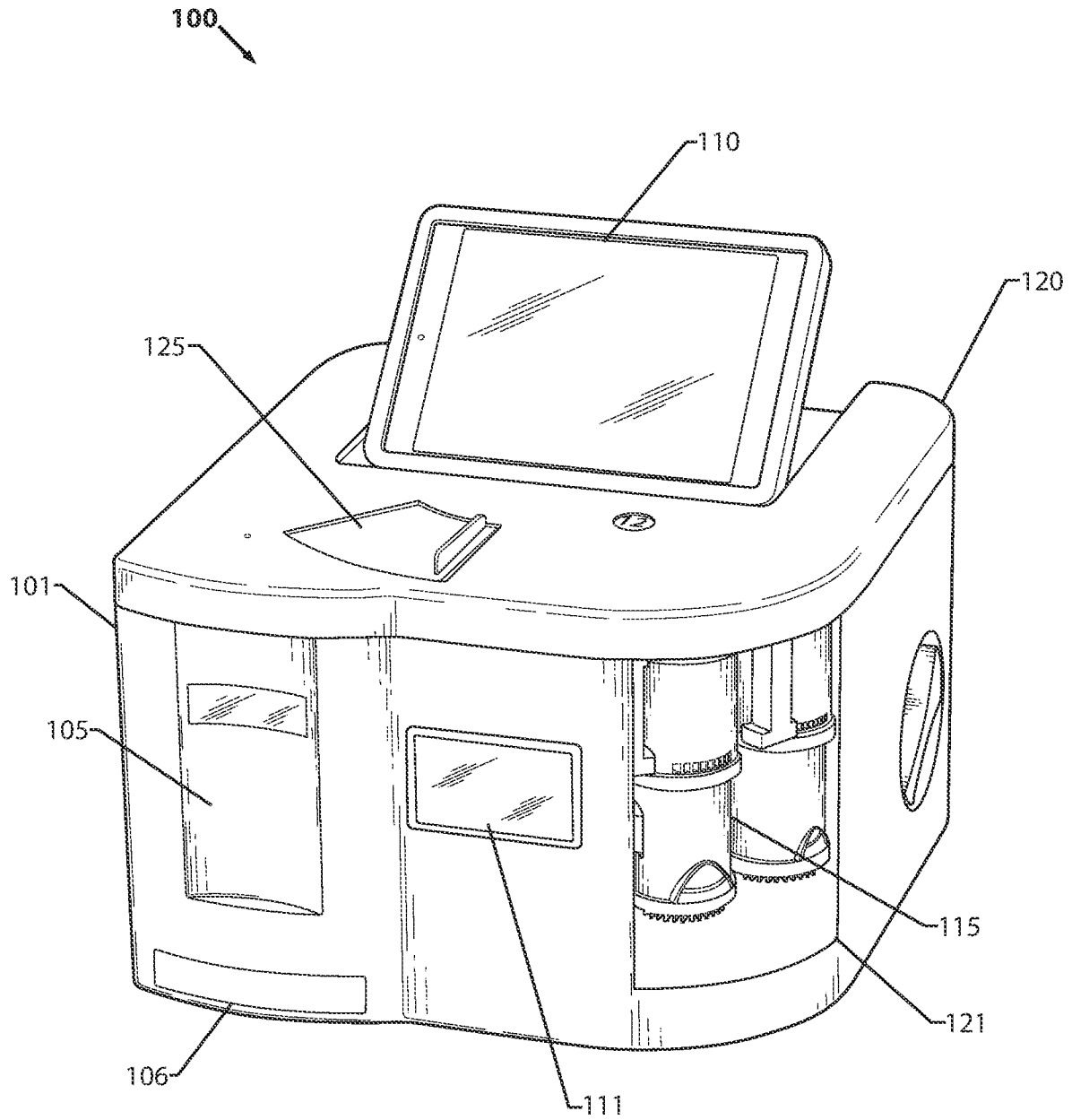

Fig.1

2/19

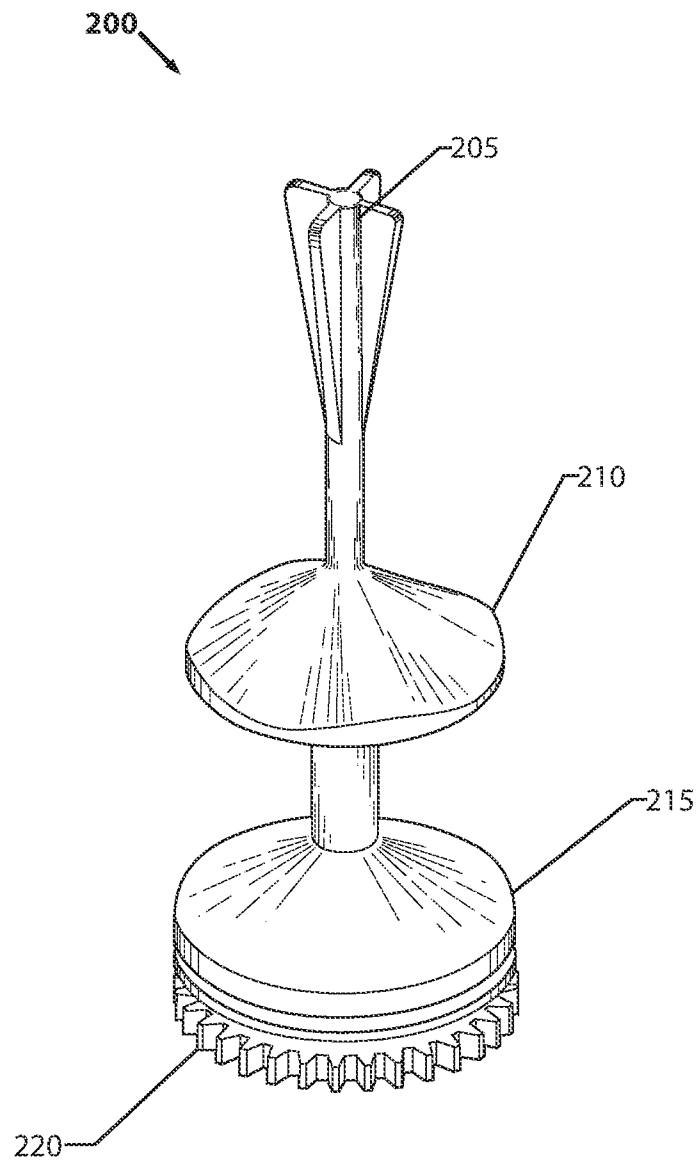

Fig.2

3/19

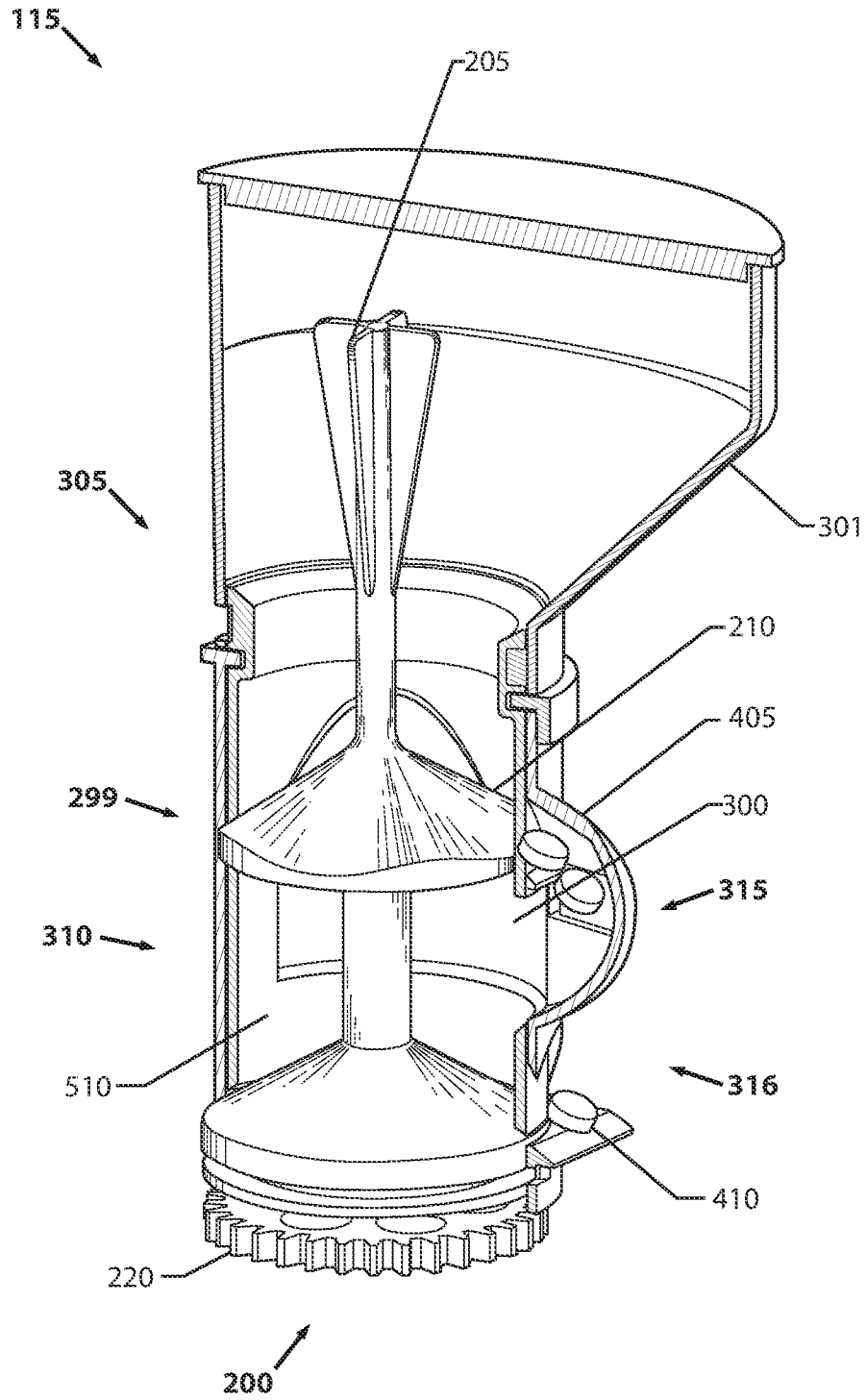

Fig.3

4/19

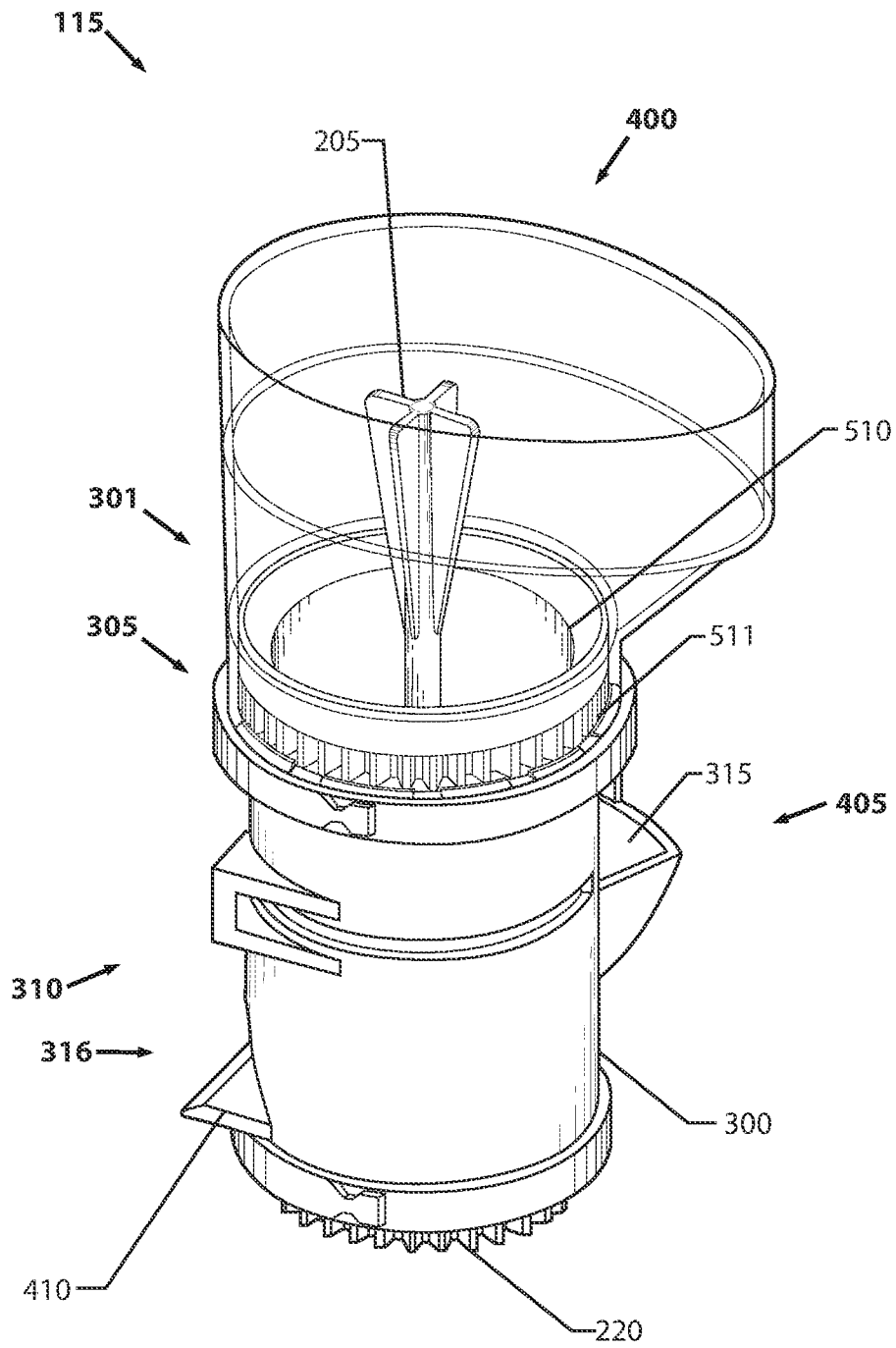

Fig.4

5/19

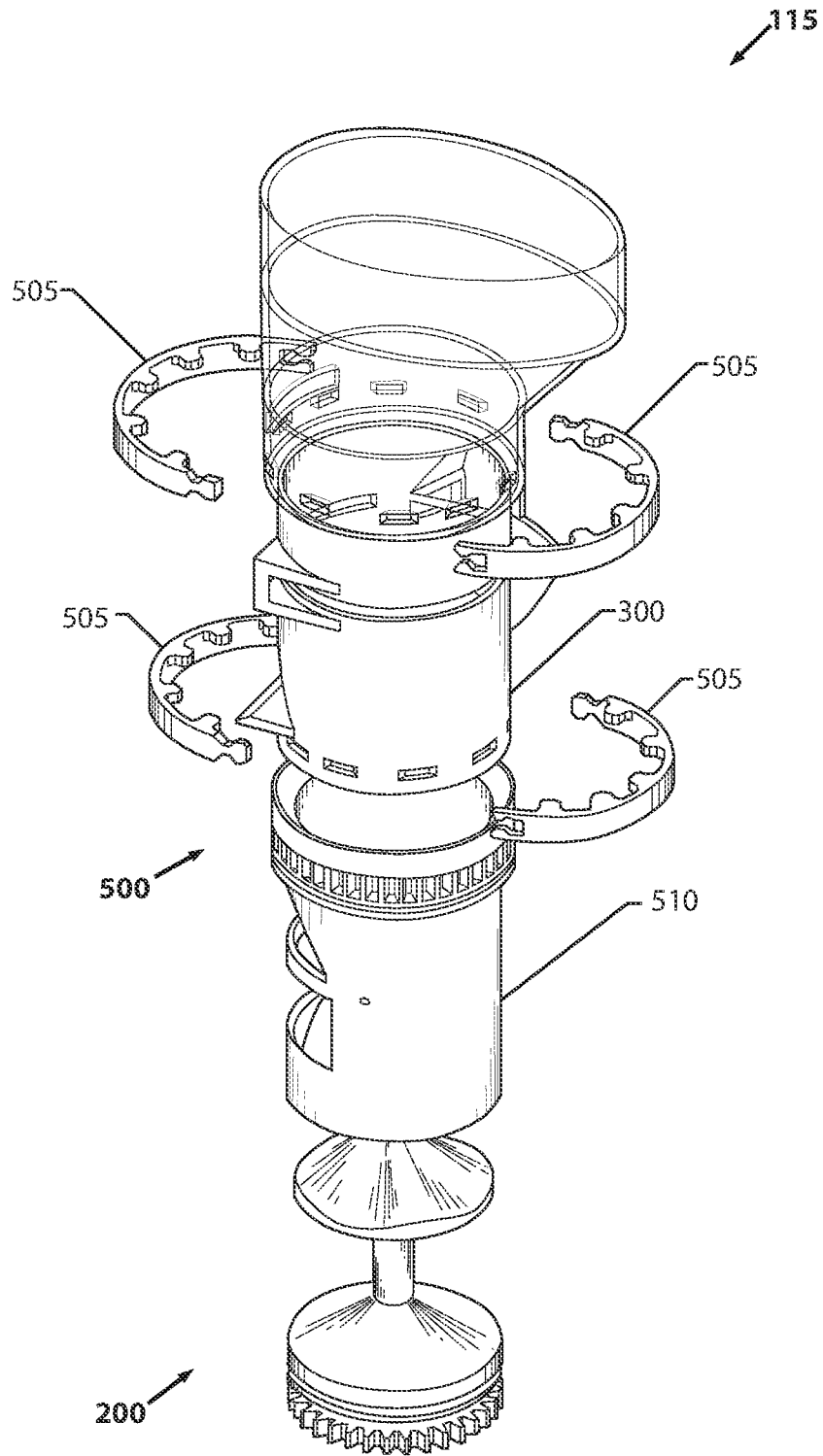

Fig.5

6/19

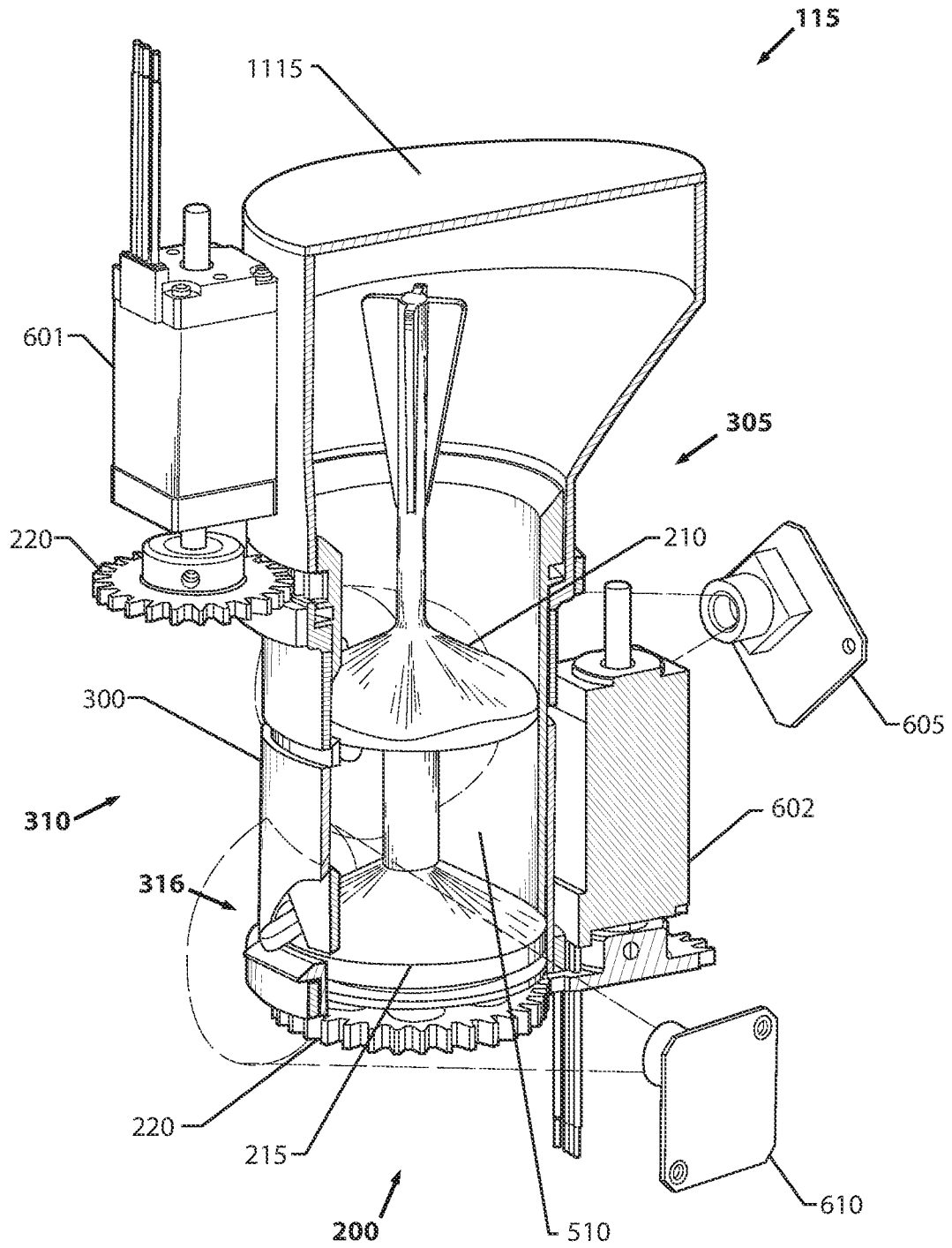

Fig.6

7/19

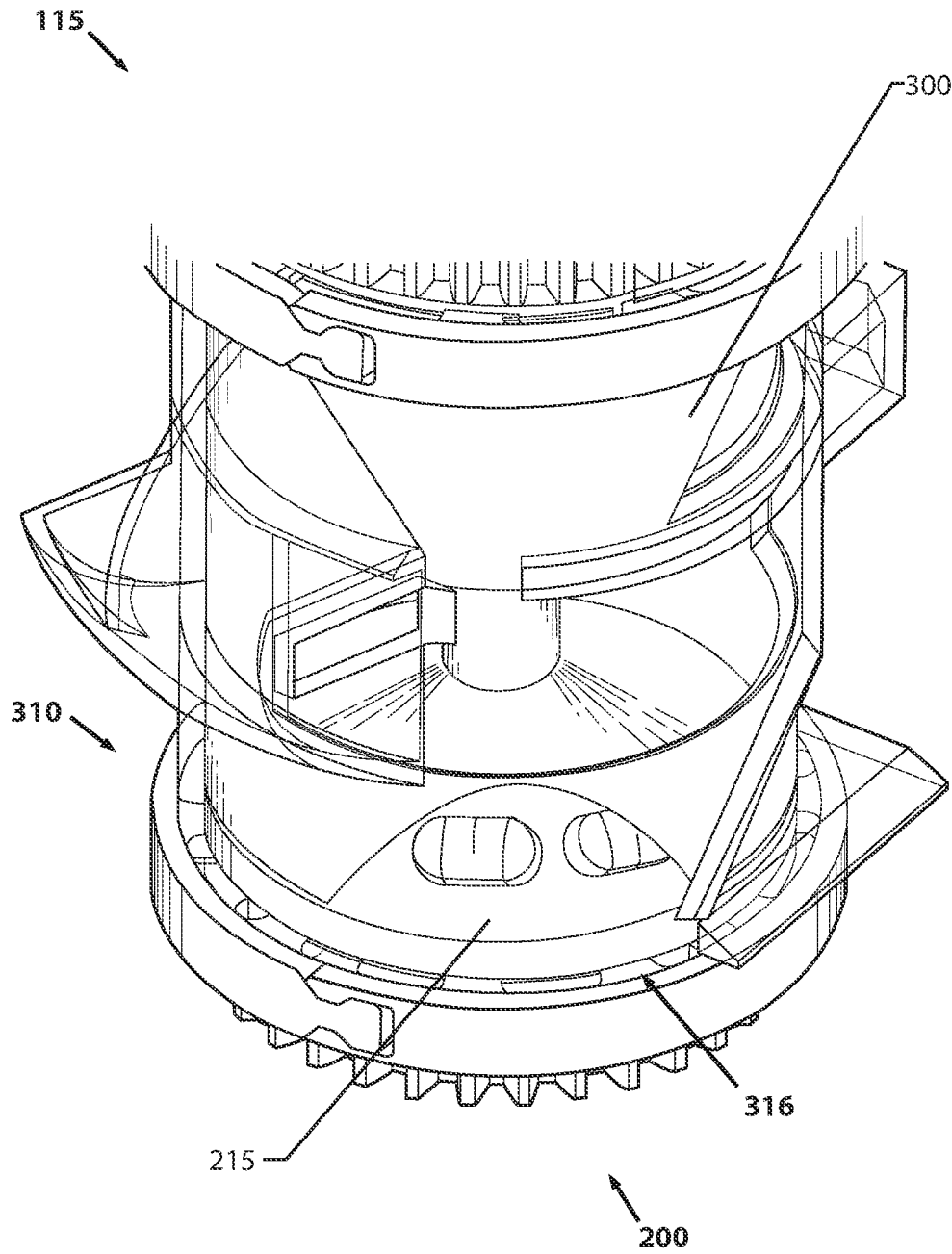

Fig.7

8/19

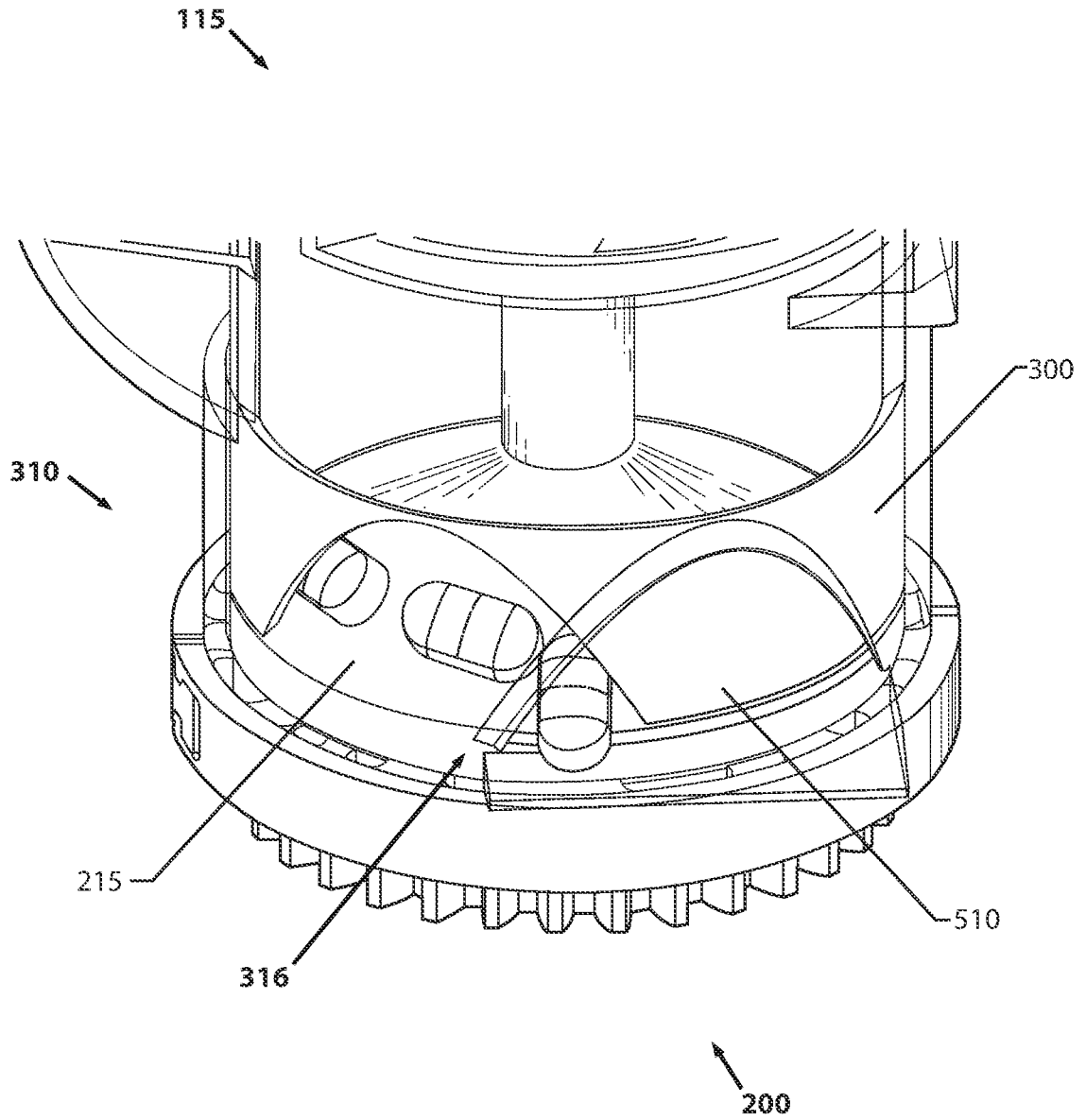

Fig.8

9/19

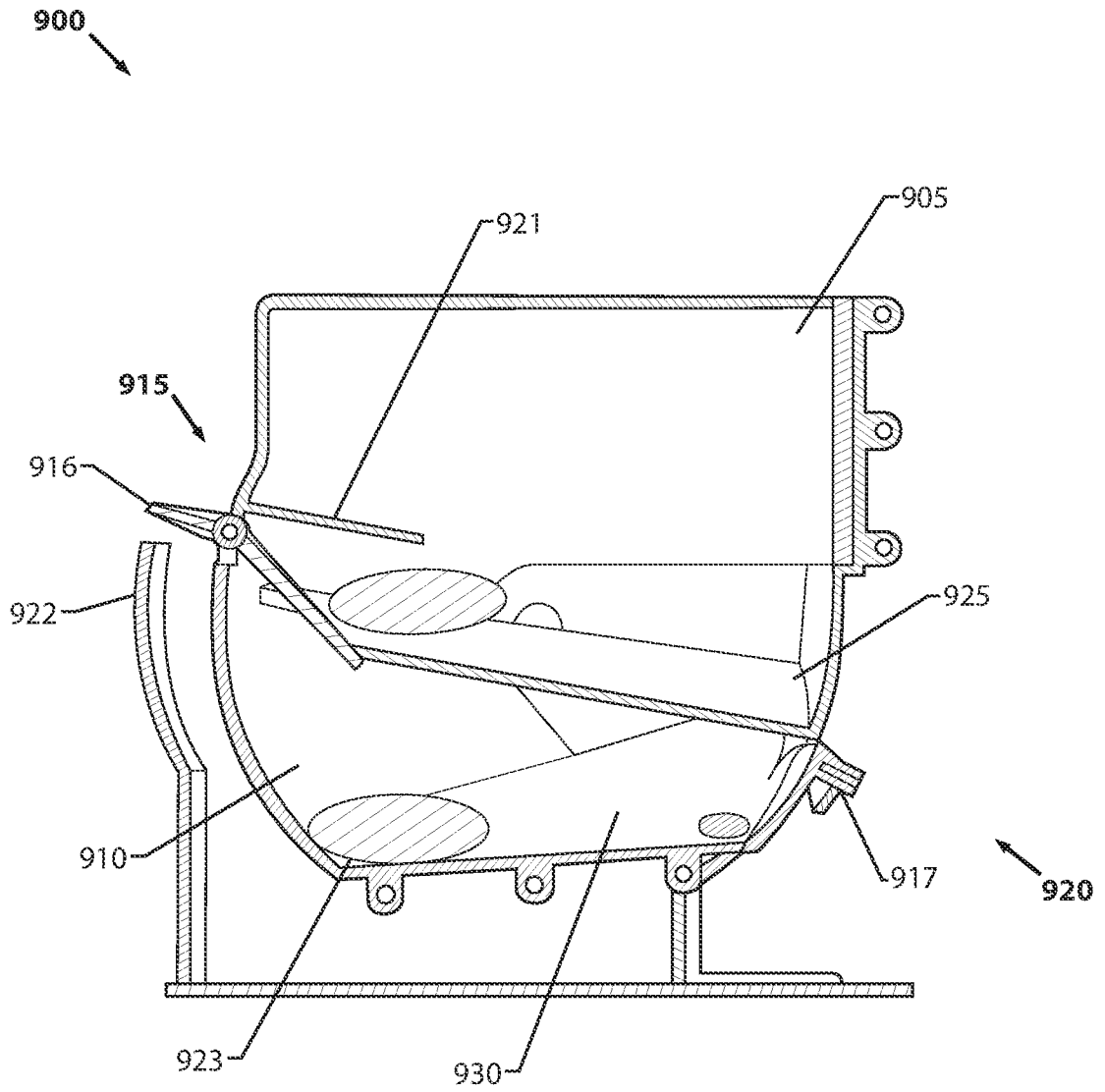

Fig.9

10/19

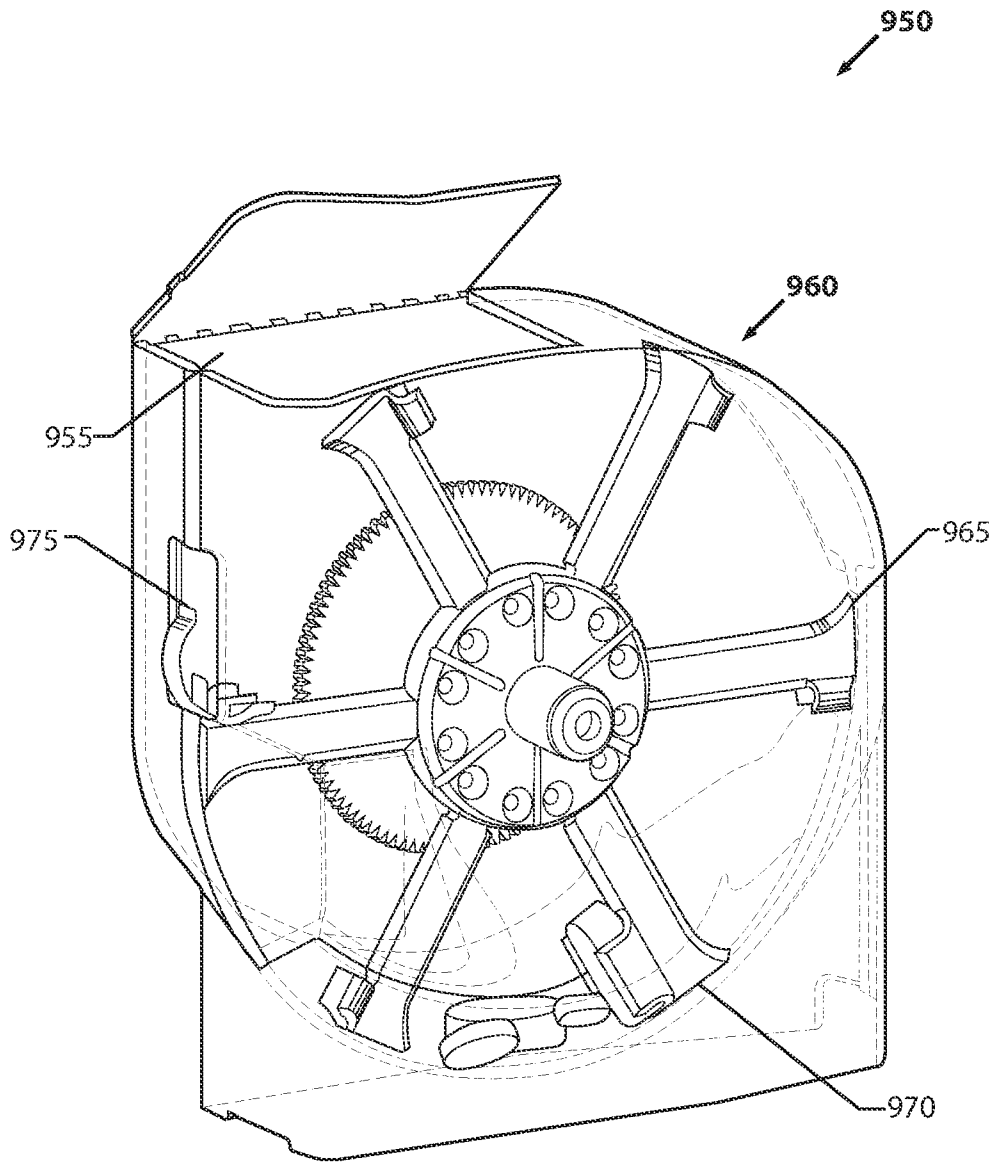

Fig. 10

11/19

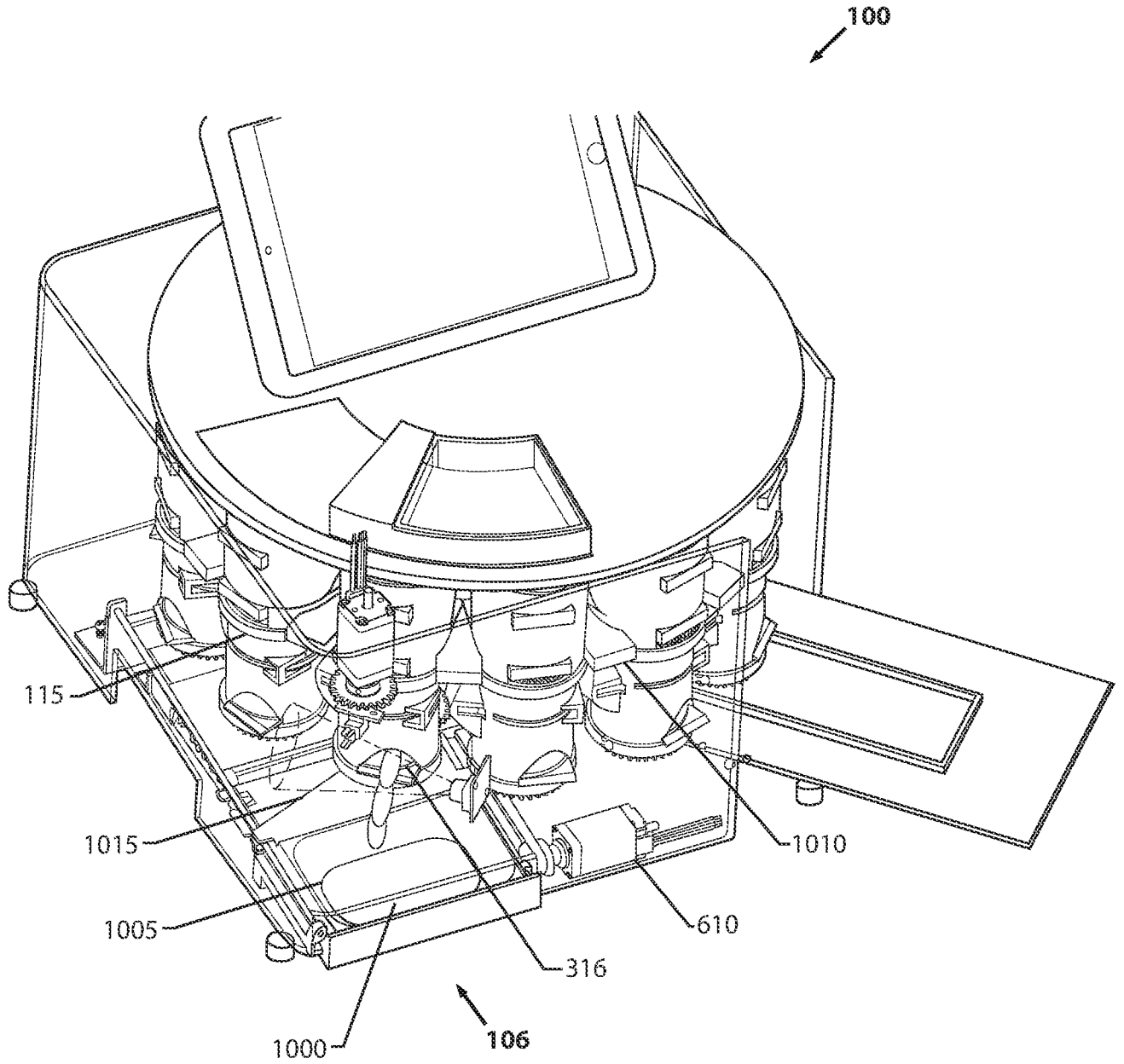

Fig. 11A

12/19

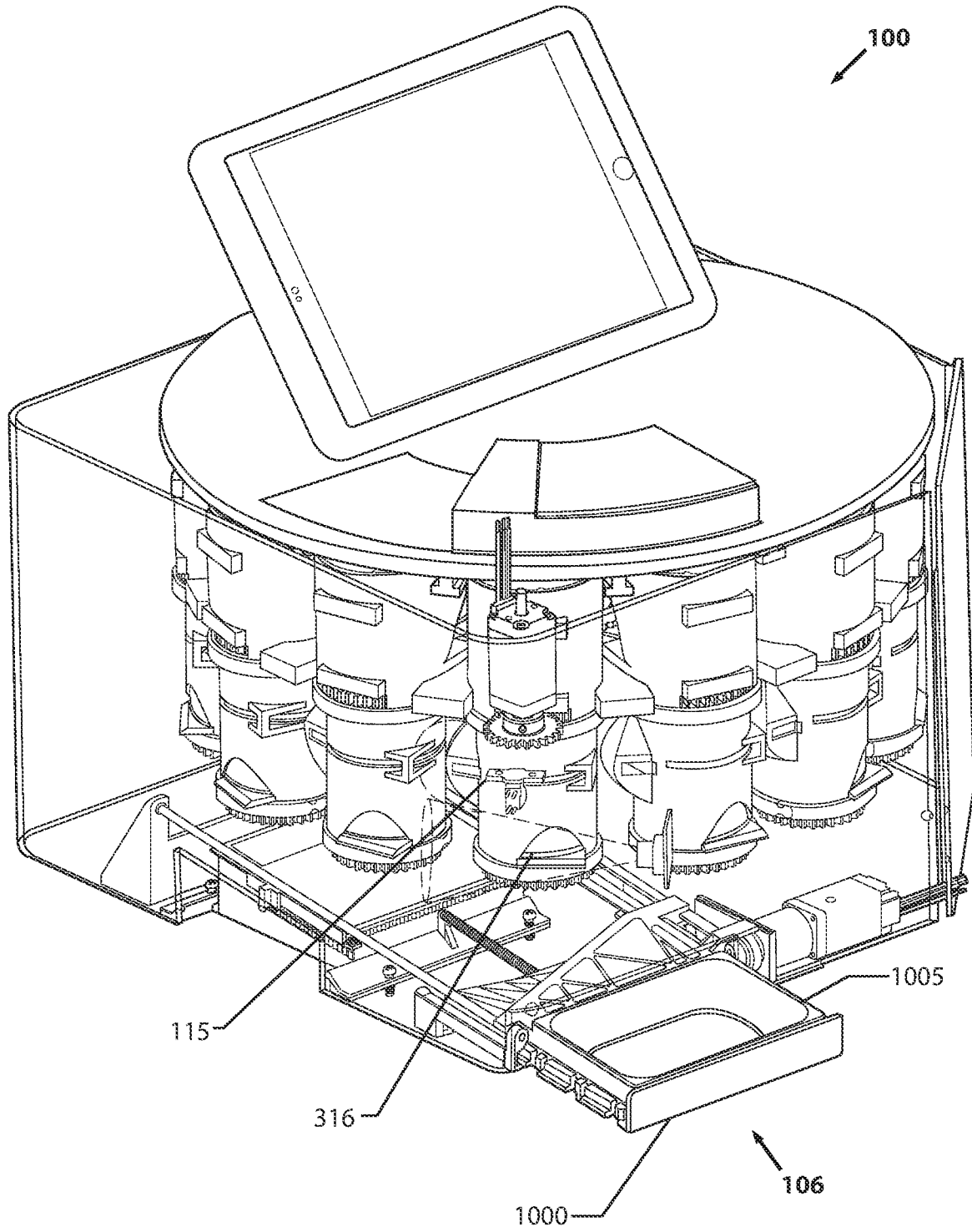

Fig. 11B

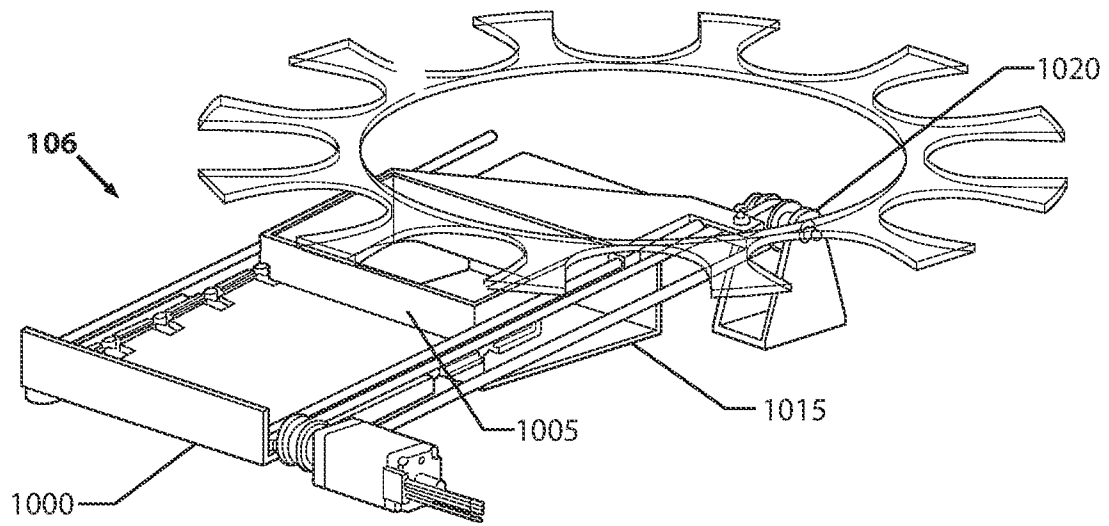

Fig.11C

14/19

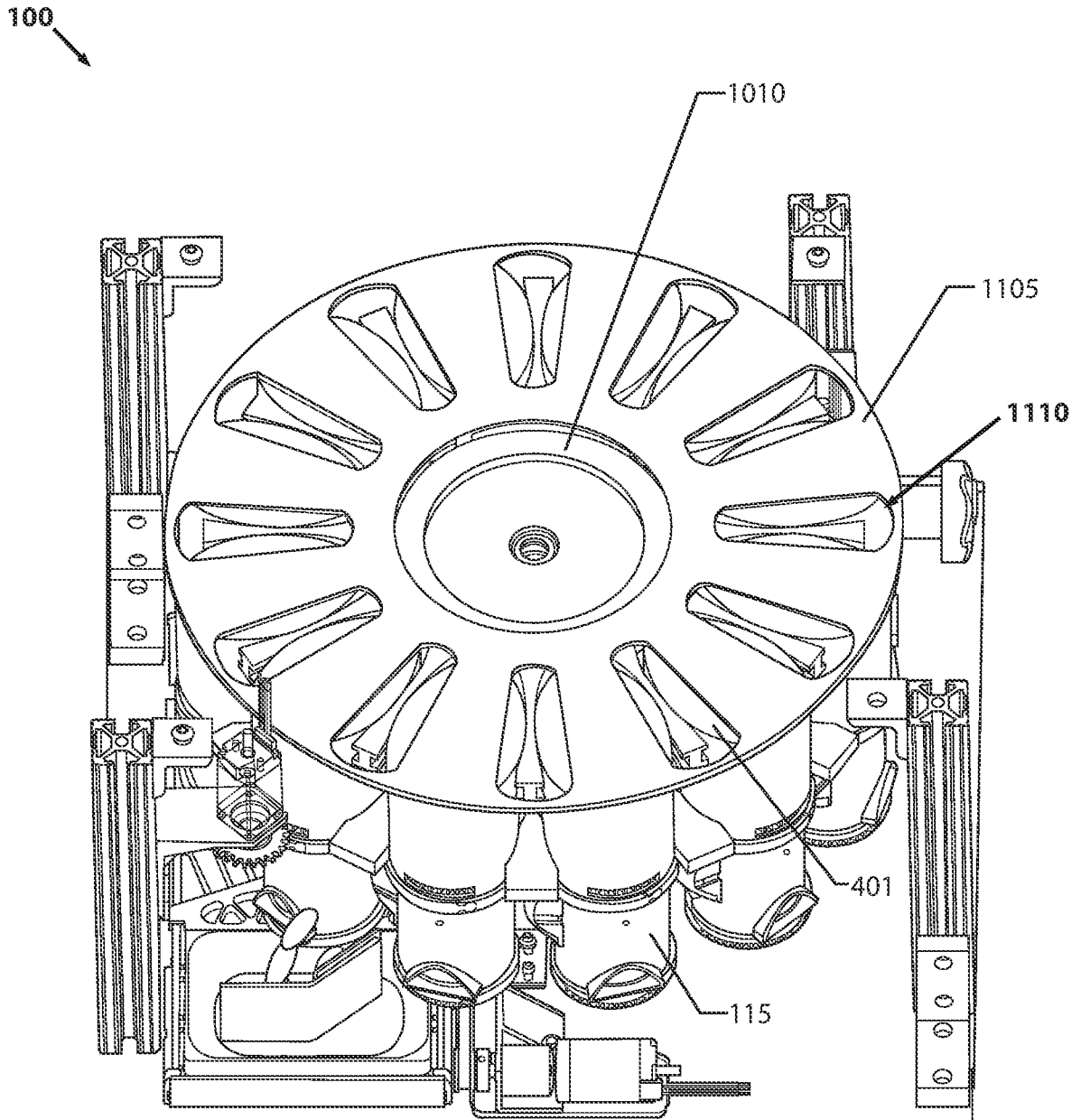

Fig.12

15/19

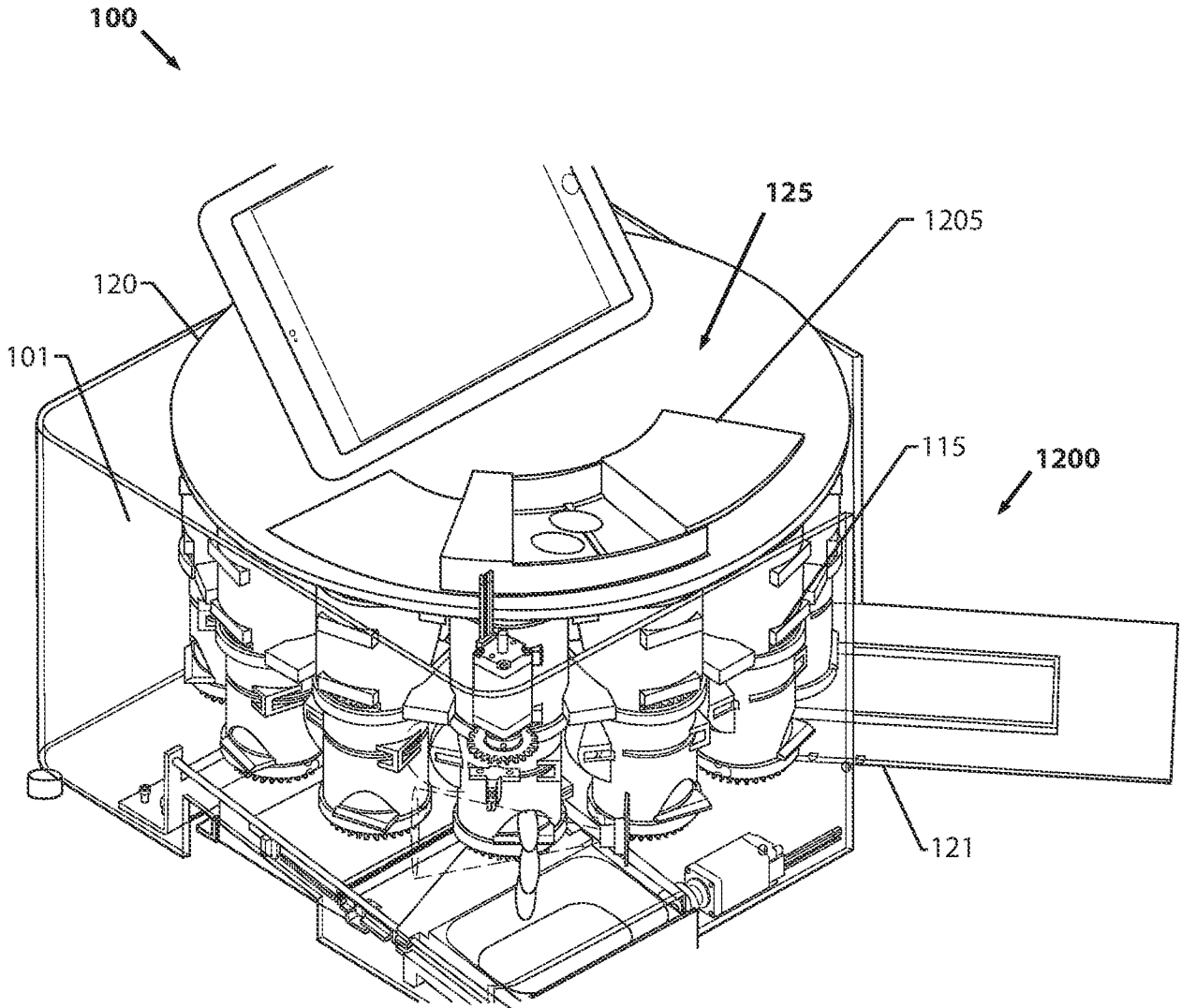

Fig. 13

1300

16/19

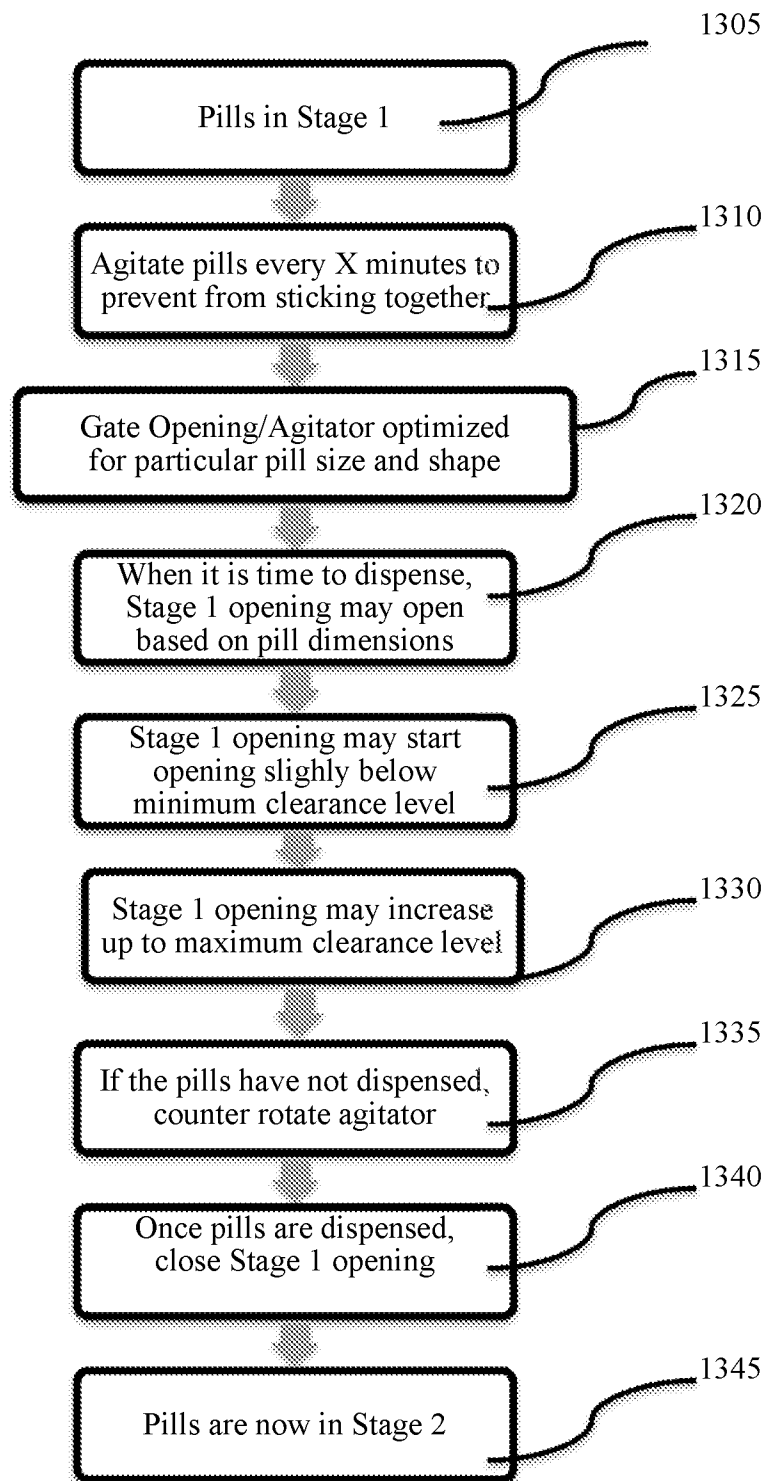

FIG. 14

1400

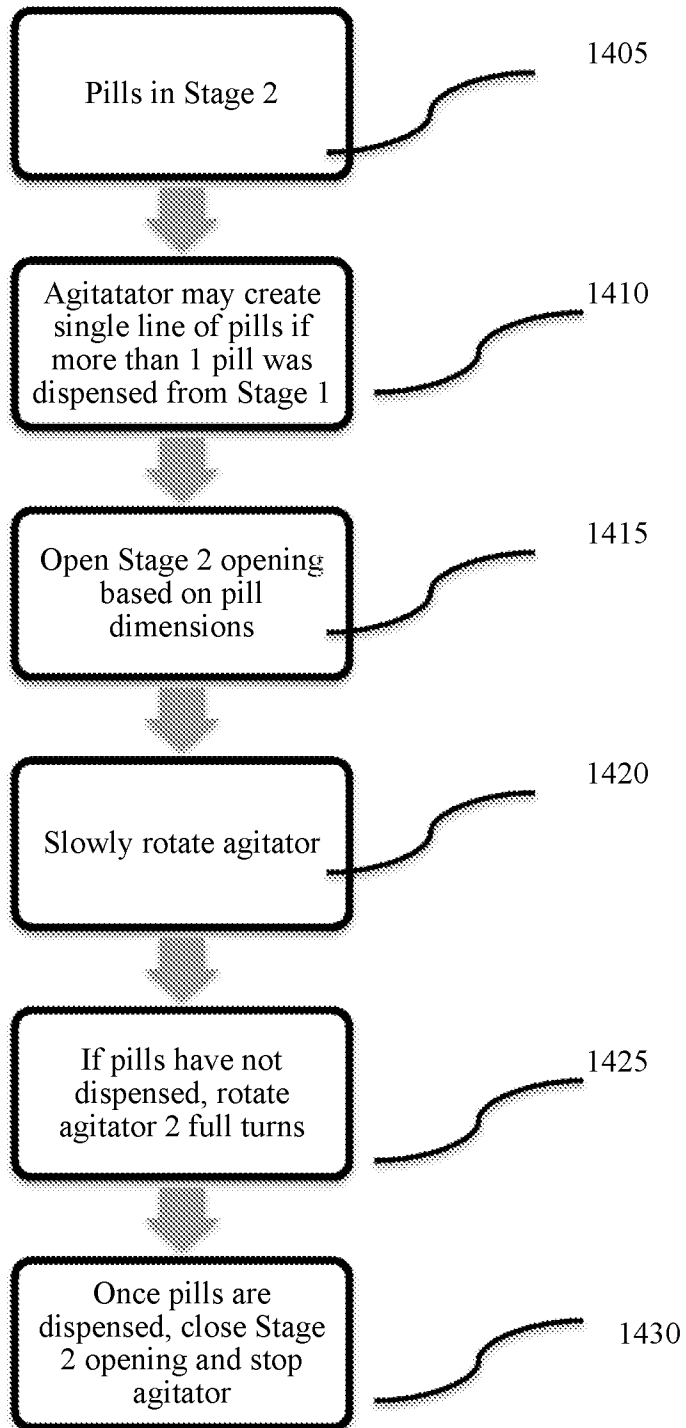

FIG. 15

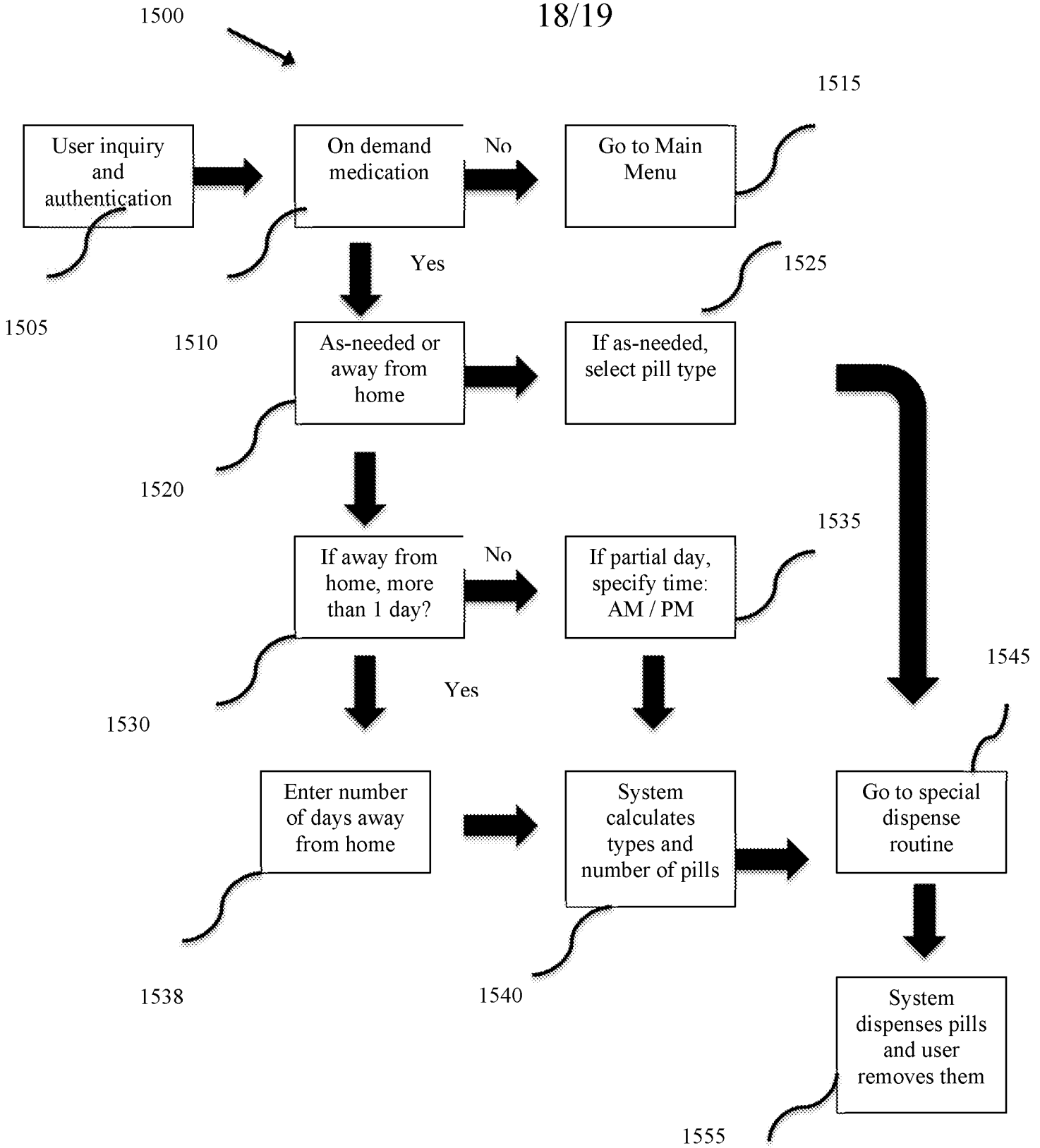

FIG. 16

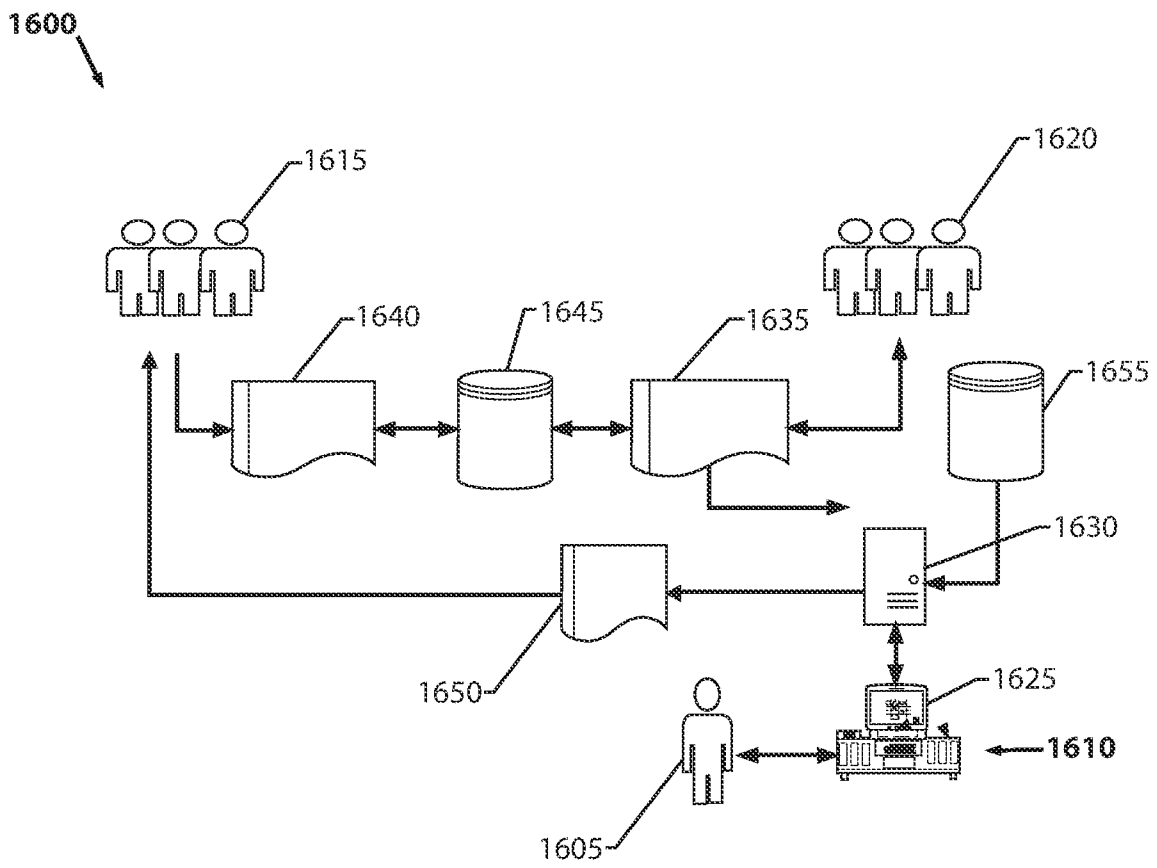

Fig.17

INTERNATIONAL SEARCH REPORT

International application No.
PCT/US2017/020959**A. CLASSIFICATION OF SUBJECT MATTER****A61J 7/00(2006.01)i, A61J 7/04(2006.01)i, G06Q 50/04(2012.01)i**

According to International Patent Classification (IPC) or to both national classification and IPC

B. FIELDS SEARCHEDMinimum documentation searched (classification system followed by classification symbols)
A61J 7/00; A61J 7/04; G06F 19/00; B65B 59/00; G07F 11/00; G06Q 50/04Documentation searched other than minimum documentation to the extent that such documents are included in the fields searched
Korean utility models and applications for utility models
Japanese utility models and applications for utility modelsElectronic data base consulted during the international search (name of data base and, where practicable, search terms used)
eKOMPASS(KIPO internal) & Keywords: automated medication adherence system, housing, electronic interface, sensor, pill delivery and lock-out module, reservoir, rotating carrier, display, data, agitation talk, actuator, chute, opening**C. DOCUMENTS CONSIDERED TO BE RELEVANT**

Category*	Citation of document, with indication, where appropriate, of the relevant passages	Relevant to claim No.
X	US 2014-0244033 A1 (UCER, SEMAHAT SERRA et al.) 28 August 2014 See paragraphs [0016]-[0025]; claim 1; Figures 1-3.	15-19
A		1-14, 20-22
A	US 2006-0071011 A1 (VARVARELIS, NICHOLAS M. et al.) 06 April 2006 See the whole document.	1-22
A	US 2014-0277702 A1 (SHAW, THOMAS J.) 18 September 2014 See the whole document.	1-22
A	US 2015-0039124 A1 (MISTOVICH, RONALD JUSTIN et al.) 05 February 2015 See the whole document.	1-22
A	US 2015-0012131 A1 (SALTSOV, LEON) 08 January 2015 See the whole document.	1-22

 Further documents are listed in the continuation of Box C. See patent family annex.

* Special categories of cited documents:

"A" document defining the general state of the art which is not considered to be of particular relevance

"E" earlier application or patent but published on or after the international filing date

"L" document which may throw doubts on priority claim(s) or which is cited to establish the publication date of another citation or other special reason (as specified)

"O" document referring to an oral disclosure, use, exhibition or other means

"P" document published prior to the international filing date but later than the priority date claimed

"T" later document published after the international filing date or priority date and not in conflict with the application but cited to understand the principle or theory underlying the invention

"X" document of particular relevance; the claimed invention cannot be considered novel or cannot be considered to involve an inventive step when the document is taken alone

"Y" document of particular relevance; the claimed invention cannot be considered to involve an inventive step when the document is combined with one or more other such documents, such combination being obvious to a person skilled in the art

"&" document member of the same patent family

Date of the actual completion of the international search

15 June 2017 (15.06.2017)

Date of mailing of the international search report

15 June 2017 (15.06.2017)

Name and mailing address of the ISA/KR

International Application Division
Korean Intellectual Property Office
189 Cheongsa-ro, Seo-gu, Daejeon, 35208, Republic of Korea

Facsimile No. +82-42-481-8578

Authorized officer

HEO, Joo Hyung

Telephone No. +82-42-481-8150

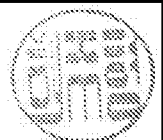

INTERNATIONAL SEARCH REPORT

Information on patent family members

International application No.

PCT/US2017/020959

Patent document cited in search report	Publication date	Patent family member(s)	Publication date
US 2014-0244033 A1	28/08/2014	None	
US 2006-0071011 A1	06/04/2006	US 7359765 B2	15/04/2008
US 2014-0277702 A1	18/09/2014	US 9245093 B2	26/01/2016
		WO 2014-145413 A2	18/09/2014
		WO 2014-145413 A3	19/03/2015
US 2015-0039124 A1	05/02/2015	None	
US 2015-0012131 A1	08/01/2015	CA 2701396 A1	22/10/2011
		CA 2796700 A1	27/10/2011
		CA 2796700 C	19/07/2016
		EP 2560603 A1	27/02/2013
		EP 2560603 A4	30/11/2016
		US 2012-0259456 A1	11/10/2012
		US 8874260 B2	28/10/2014
		US 9524377 B2	20/12/2016
		WO 2011-130840 A1	27/10/2011