



(51) International Patent Classification:

B62L 3/08 (2006.01) *B60T 1/08* (2006.01)
B62L 3/02 (2006.01) *F16L 27/093* (2006.01)
B60T 8/26 (2006.01) *F16L 41/04* (2006.01)

(21) International Application Number:

PCT/IB2017/057378

(22) International Filing Date:

24 November 2017 (24.11.2017)

(25) Filing Language:

English

(26) Publication Language:

English

(30) Priority Data:

201641040199 24 November 2016 (24.11.2016) IN

(71) Applicant: **TVS MOTOR COMPANY LIMITED**

[IN/IN]; Jayalakshmi Estates, No.29 (old No.8) Haddows Road, Chennai 600006 (IN).

(72) Inventors: **ARULMURUGAN, P S**; Tvs Motor Company

Limited, Jayalakshmi Estates, No.29 (old No.8) Haddows Road, Chennai 600006 (IN). **KAKKANATTU MATH-
EWS, Winney**; Tvs Motor Company Limited, Jayalakshmi Estates, No.29 (old No.8) Haddows Road, Chennai 600006 (IN).

(81) Designated States (unless otherwise indicated, for every

kind of national protection available): AE, AG, AL, AM, AO, AT, AU, AZ, BA, BB, BG, BH, BN, BR, BW, BY, BZ, CA, CH, CL, CN, CO, CR, CU, CZ, DE, DJ, DK, DM, DO, DZ, EC, EE, EG, ES, FI, GB, GD, GE, GH, GM, GT, HN, HR, HU, ID, IL, IN, IR, IS, JO, JP, KE, KG, KH, KN, KP, KR, KW, KZ, LA, LC, LK, LR, LS, LU, LY, MA, MD, ME, MG, MK, MN, MW, MX, MY, MZ, NA, NG, NI, NO, NZ, OM, PA, PE, PG, PH, PL, PT, QA, RO, RS, RU, RW, SA, SC, SD, SE, SG, SK, SL, SM, ST, SV, SY, TH, TJ, TM, TN, TR, TT, TZ, UA, UG, US, UZ, VC, VN, ZA, ZM, ZW.

(54) Title: A TWO-WHEELED VEHICLE WITH SYNCHRONIZED BRAKING SYSTEM

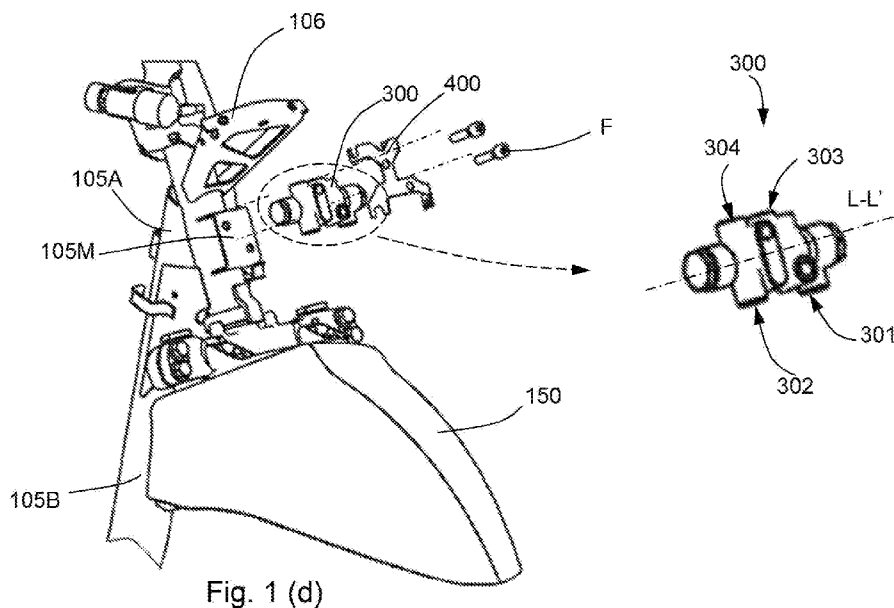

Fig. 1 (d)

(57) **Abstract:** The present subject matter provides a motor vehicle comprising a synchronized braking system. A frame assembly (105) comprising a head tube (105A) is disposed in a front portion thereof. A pressure control device (300) of the synchronized braking system (200) is functionally connected to a front wheel brake (205) through a second output hose (240) and is functionally connected to a rear wheel brake (210) through a first output hose (235). The pressure control device (300) is capable of being actuated by a synchronous brake lever (220). The pressure control device (300) is securely disposed in proximity to the head tube (105A). The vehicle (100) enables provision of pressure control device (300) securely to the vehicle (100) with one or more hose(s) provided at optimum lengths.



(84) Designated States (*unless otherwise indicated, for every kind of regional protection available*): ARIPO (BW, GH, GM, KE, LR, LS, MW, MZ, NA, RW, SD, SL, ST, SZ, TZ, UG, ZM, ZW), Eurasian (AM, AZ, BY, KG, KZ, RU, TJ, TM), European (AL, AT, BE, BG, CH, CY, CZ, DE, DK, EE, ES, FI, FR, GB, GR, HR, HU, IE, IS, IT, LT, LU, LV, MC, MK, MT, NL, NO, PL, PT, RO, RS, SE, SI, SK, SM, TR), OAPI (BF, BJ, CF, CG, CI, CM, GA, GN, GQ, GW, KM, ML, MR, NE, SN, TD, TG).

Declarations under Rule 4.17:

— *as to applicant's entitlement to apply for and be granted a patent (Rule 4.17(ii))*

Published:

— *with international search report (Art. 21(3))*

A TWO-WHEELED VEHICLE WITH SYNCHRONIZED BRAKING SYSTEM

TECHNICAL FIELD

[0001] The present subject matter, in general, relates to a two-wheeled motor vehicle, and, in particular relates, to the two-wheeled motor vehicles provided with a synchronized braking system.

5

BACKGROUND

[0002] In the last few decades, two-wheeler automobile industry has shown a remarkable growth and development, in terms of technology as well as sales. Due to consistent advancement in technology, two-wheeled vehicles, such as bicycles, motorcycles, scooters and lightweight scooters, have succeeded in maintaining their popularity among different sections of society. Different sections of society, based on their requirement, utilize the two-wheeled vehicles for various purposes, such as a recreational activity, a means of transportation, and for sports activities. As a result, it becomes pertinent for the two-wheeler automobile industry to constantly develop and modify the components of the two-wheeled vehicles to suit requirements of different riders.

10

[0003] In accordance with the same ideology, various types of braking systems have been developed for facilitating braking functionalities in the two-wheeled vehicles. Conventionally, braking systems that allow simultaneous actuation of a front brake and a rear brake upon application of a single brake lever have gained widespread popularity across the globe.

15

[0004] Generally, two-wheeled vehicles are provided with a pair of mechanically operated drum brakes. However, with the advent of braking technology, hydraulically operated disc brakes have come to use. Such disc brakes are capable of being installed on both front and rear wheels. However, vehicles with disc brakes installed only on to front wheels are most commonly used. Such a determination of whether to use two disc brakes or one is primarily based on the capacity of the vehicle and the maximum load capable of being carried by the vehicle. Generally, for lesser capacity vehicles that are not expected to reach very high-speed levels are provided with a single disc brake, preferably, on to the front

20

25

wheel of the vehicle. However, with varying applications, a disc brake is provided on the rear wheel also.

BRIEF DESCRIPTION OF THE DRAWINGS

[0005] The detailed description is described with reference to the accompanying
5 figures. In the figures, the left-most digit(s) of a reference number identifies the figure in which the reference number first appears. The same numbers are used throughout the drawings to reference like features and components.

[0006] Fig. 1 (a) illustrates a left side view of an exemplary two-wheeled motor vehicle, in accordance with an embodiment of the present subject matter.

10 [0007] Fig. 1 (b) illustrates a frame assembly of the vehicle provided with selected vehicular parts, in accordance with the embodiment depicted in Fig. 1 (a).

[0008] Fig. 1 (c) depicts an enlarged view of the frame assembly of the vehicle, in accordance with the embodiment depicted in Fig. 1 (b).

15 [0009] Fig. 1 (d) depicts an exploded view of the pressure control device of the braking system employed on the vehicle, in accordance with the embodiment depicted in Fig. 1 (b).

[00010] Fig. 1 (e) depicts an isometric view of an orientation bracket, in accordance with the embodiment of Fig. 1 (b).

20 [00011] Fig. 1 (f) depicts an exploded view of the pressure control device and assembly thereof, in accordance with the embodiment depicted in Fig. 1 (c).

DETAILED DESCRIPTION

[00012] Conventionally, two-wheeled vehicles or the like are provided with a braking system for slowing or stopping the vehicle. The braking system, usually, includes at least one brake assembly, such as a front wheel brake assembly and a
25 rear wheel brake assembly for a front wheel and a rear wheel, respectively. Such brake assemblies may include, but are not limited to a cam lever, a cam pin, and a pair of friction pads or other means of actuation of the friction pads. Further, each of the front wheel brake assembly and the rear wheel brake assembly is connected to a brake lever for actuation. For example, the brake lever may be coupled to a
30 pair of friction pads for applying friction to each wheel of the two-wheeled vehicle, as and when required. The brake lever can be connected to the brake assembly in a variety of ways. For example, the brake lever can be connected to

the brake assembly by means of a cable. In such a case, one end of the cable may be secured to the brake assembly, and the other end of the cable may be secured to the brake lever. Consequently, actuation of the brake lever may result in actuation of the brake assembly and subsequently, the brake may be applied. Nevertheless, 5 the brake assembly can be connected to the lever by means of hydraulic system. Also, in some applications, combination of the cable and the hydraulic means is used.

[00013] Generally, the front wheel and the rear wheel are provided with separate braking systems. Conventional two-wheeler braking systems usually 10 either include hand-operated brakes for both the wheels or include a combination of hand-operated and foot-operated brakes. In the latter case, generally, the front wheel brakes are hand-operated, and include a front wheel brake lever mounted on a handle of the two-wheeled vehicle for actuation, whereas the rear wheel brakes can be foot-operated by a rear wheel brake lever provided near a footrest of the 15 rider. However for saddle type scooters, both brakes may be actuated by hand operated brake levers.

[00014] During operation of the brakes, usually, riders apply the rear wheel brake alone. Such a practice stems from the fact that actuating both the brake levers at the same time may be inconvenient for the rider. In addition, when the 20 front wheel brake is applied weight transfer towards the front wheel cause the front wheel to brake abruptly, and may result in a sudden jerk to the vehicle. The sudden jerk may affect the ride quality and may disturb the balance and stability of the vehicle leading to an accident. However, on the other hand, the braking force applied for application of braking force to the rear wheel may have to be 25 limited, to prevent skidding of the vehicle. As a result, the deceleration experienced by the vehicle may also be limited and subsequently, the stopping distance of the vehicle may be significantly large.

[00015] Conventionally, in order to address the above-mentioned concerns, braking systems that allow simultaneous actuation of a front brake and a rear 30 brake by application of a single brake lever have been developed. Such braking system is capable of uniting the braking operation of both the front wheel brake and the rear wheel brake with the help of a single brake lever, for example the rear

wheel brake lever. Accordingly, upon actuation of the single brake lever, such a braking system may allow distribution of braking force to the front wheel as well as the rear wheel of the vehicle. Therefore, the front wheel brake and the rear wheel brake can be simultaneously applied by actuating one brake lever, for example, the rear wheel brake lever. In addition to being convenient for the rider, such braking systems may ensure that the deceleration of the vehicle can be increased and subsequently, the stopping distance may be reduced. Further, as would be understood, in two-wheeled vehicles with such braking systems, a front wheel brake lever may also be provided to independently operate the front wheel brake. Such systems having front and rear brake system actuated in a coordinated manner termed as synchronized braking system.

[00016] Generally, the motor vehicles like two-wheeled vehicles are provided with disc brake for certain application or to improve safety. The disc brake is provided on the front wheel and may be installed on the rear wheel. The disc brake is actuated through hydraulic means. Therefore, a pressure control device is used in order to distribute the pressure or force by a pre-determined pressure or at a pre-determinate ratio to the front wheel brake and the rear wheel brake. The pressure control device is to be securely mounted to the vehicle for optimum functioning of the braking system, which is an essential safety system of the vehicle. However, presence of various vehicle systems, moving parts complicates the mounting of the pressure control device. Also, the pressure control device is provided hydraulic connectors and the orientation, angle of such connectors is essential during assembly as it heavily impacts the brake hose routing in the vehicle layout. Conventionally, anti-rotation members are provided in casting of the pressure control device. However, such pressure control device limits the flexibility of use various vehicle layouts. Additionally, the routing of the hose in case of disc brake and routing of cables in case of drum brakes, their length determines the performance of the brake system. Longer hose or cable length tend to lead to spongy feel of the brake system and leads to low durability owing to friction losses. Thus it is important to have an optimum location for the pressure control device without compromising the performance and durability of the system. There is a need to locate the device on the sprung mass of the vehicle & at

the same time securely located in case of minor accidental fall of the vehicle. Additionally, it is required to locate the device at optimum distance from majority of the components of the vehicle as well as substantially away from the engine induced vibrations to minimize disturbances.

5 [00017] Moreover, in a two-wheeled with a step-through type layout, which is commonly called as "scooter", further complicates implementation of the synchronized braking system. The scooter has a step-through space and also provides a utility box. This reduces the available space on the vehicle for mounting the vehicle parts. The power unit and other components including air
10 induction system, exhaust system, etc. are tightly packaged in the vehicle. The pressure control device, which an essential element of the synchronized braking system of vehicles with front and rear disc brakes is to be securely mounted to the vehicle. The pressure control device is one of biggest parts of the synchronized braking system, which requires substantial amount space. Moreover, hydraulic
15 tubing/piping with the associated pressure control device require ample amount of space and also require longer hoses thereby increasing cost of the system. Also, the piping is made of an elastic material, which is prone to fail upon reciprocating movement of the suspension, especially at the joining portions of the hydraulic piping to the pressure control device. Failure of the pressure control device results
20 in drastic safety related issues as the braking system is an essential safety system.

[00018] Therefore, the pressure control device is to be mounted to vehicle and at the same time without affecting the functionality, as it is an essential element of the braking system. In addition, the pressure control device is to be securely mounted in the tightly packed vehicle layout, without modifying the layout of the
25 vehicle.

[00019] Thus, it is an object of the present subject matter to address the aforementioned and other problems stated above.

[00020] Hence, the present subject matter provides a motor vehicle provided with a synchronized braking system. The synchronized braking system includes a
30 pressure control device functionally connected to at least one brake lever adapted to synchronously actuate the rear wheel brake and the front wheel brake. The

pressure control device is disposed in proximity to a head tube of frame assembly of the vehicle.

[00021] It is a feature of the present subject matter, that the pressure control device disposed in proximity to the head tube is a mechanically or
5 electromechanically operated to provide braking force to the front wheel brake and the rear wheel brake upon actuation of the at least one brake lever, which acts a synchronous brake lever that is preferably a rare brake lever. In other words, the pressure control device of the synchronized braking system enables actuation at
10 least two brakes installed on different wheels by the operation of a single control, which is the synchronous brake lever. Moreover, the front lever is capable of independently actuating only the front brake lever.

[00022] At least one brake lever is mounted to a handle bar assembly that is rotatable about a head tube of the frame assembly. In an embodiment, both the front brake lever and the rear brake lever are mounted to the handle bar assembly.
15 The handle bar assembly is connected to the front wheel through suspension(s) and rotatable about the head tube through a steering tube. The front wheel brake is installed on at least one front wheel. Preferably, the pressure control device is mounted to the head tube, which is in proximity to the handle bar assembly and the front wheel brake thereby reducing the piping length. It is a feature of the
20 present subject matter that the friction losses, due to the flow of fluid, are reduced due to the reduced piping lengths. In a motorcycle type of vehicle, one brake lever is mounted to the handle bar assembly that is hand operated and other brake lever, which is synchronous brake lever, is mounted near the rider foot to enable foot operation.

[00023] The pressure control device is disposed in proximity to the head tube of the frame assembly, and the pressure control device is at least approximately equidistant from at least one brake lever mounted to a handle bar assembly rotatably supported by the head tube and in proximity to said front wheel brake.
25 Therefore, the pressure control device at least approximately equidistant from at least one brake lever mounted to the handle bar assembly and from the front
30 wheel brake, whereby the pressure control device is in proximity to the brake

lever(s) mounted to handle bar assembly and in proximity to the front wheel brake thereby providing optimum and short routing lengths for hose(s).

5 [00024] It is a feature that a first input hose connecting a synchronous brake lever to the pressure control device, a second input hose connecting a front brake lever to the pressure control device, and a second output hose connecting the pressure control device to the front wheel brake, wherein ratio of length of hose with maximum length to the length of another hose with minimum length being in the range of 0.8 to 1.2 whereby the vehicle with the pressure control device provides optimum hose length.

10 [00025] In an embodiment, the front brake lever is connected to the pressure control device. Therefore, the front wheel brake is also actuated through the pressure control device.

15 [00026] It is an additional of the present subject matter that the vehicle, specifically the pressure control device assembly, is capable of supporting the pressure control device, which is capable of actuating the front wheel brake independently, irrespective of the size of the pressure control device. It is one more advantage that the vehicle layout is retained in spite of mounting aforementioned pressure control device.

20 [00027] It is another feature that the pressure control device is mounted to the head tube, which is substantially at lateral center of the vehicle thereby retaining the weight distribution of the vehicle. Further aspect being, the motor vehicle provides the flexibility to bring the center of the vehicle to vehicle lateral center by disposing the pressure control device at an offset to counter-balance the center of gravity.

25 [00028] The present subject matter provides the flexibility for the pressure control device disposed in proximity to the head tube is positioned substantially at along a lateral centre of the vehicle. This enables in maintaining a centre of gravity of the vehicle in lateral direction as a centre of gravity of the pressure control device and a centre of gravity of the vehicle are provided in line providing
30 lateral balance.

[00029] It is yet another feature that the present subject matter enables the pressure control device to be disposed at a lateral offset from a lateral centre of the vehicle and in proximity to the head tube whereby the pressure control device balances a centre of the gravity of the vehicle. The direction of offset of the pressure control device is substantially opposite to the lateral direction of the vehicle at which the centre of gravity shifts when the pressure control device is not present.

[00030] Further, it is an additional advantage that the pressure control device disposed in proximity to the head tube is substantially away from the power unit which is one of the heavy parts of the vehicle thereby providing balance of weight or centre of gravity in the longitudinal direction of the vehicle.

[00031] It is an advantage that the pressure control device can be retrofitted to the head tube of the frame assembly.

[00032] It is an additional feature that the pressure control device is securely disposed away from the power unit of the vehicle that is prone to vibrations that could otherwise affect the function of the pressure control device. Thus, the reliable operation of the system is improved.

[00033] In an embodiment, the pressure control device is disposed in proximity to the head tube and is supported by at least one of the head tube or the main tube. It is an advantage that the pressure control device is securely and rigidly mounted to the structural member of the vehicle.

[00034] It is an aspect that the length of the connecting pipes is/are provided with optimum length to accommodate the rotation motion of the handle bar assembly and to accommodate the reciprocating motion of the suspension. In an embodiment, the synchronized braking system is provided with both flexible and rigid pipes, wherein rigid pipes are disposed at non-moving part portion(s) of the vehicle.

[00035] It is yet another aspect that, in an embodiment, the connecting pipes are provided with intermediate connectors that connect hoses to the pressure control device. The intermediate joints include banjo joints connected to the ports of the pressure control device.

[00036] It is a feature of the present subject matter that an orientation bracket is provided abuttingly disposed adjacent to the pressure control device, wherein the orientation bracket is provided with plurality of arm members that are provided with receiving portions to enable correct/fool proof fitment mounting of the intermediate joints to the respective ports. It is an additional advantage that the failure due to wrong connections is eliminated.

[00037] It is an additional feature that the orientation member supports intermediate connectors to have a specific orientation whereby the hose being connected to the intermediate connector is also retained in desired orientation.

[00038] It is an additional advantage that the orientation bracket being independent of the pressure control valve enables use of different orientation bracket with different vehicle layout to suit the hose routing for respective vehicle.

[00039] The pressure control device is securely mounted to the frame assembly in proximity to the head tube with a long axis of the pressure control device disposed in at least one orientation with the long axis disposed along an axis parallel to the lateral direction or longitudinal direction of the vehicle. The present subject matter provides flexibility in mounting the pressure control device in any desired orientation including at an inclination with respect to the longitudinal axis of the vehicle.

[00040] It is an aspect that the pressure control device includes at least one input port disposed in a downward direction to enable smooth curved routing of one or more hoses connecting the at least one brake lever mounted to the handle bar assembly to the pressure control device. This further enables the hoses to be connected with larger radius curvature with reduced flow resistance thereby by providing desired braking performance.

[00041] It is an aspect that the pressure control device includes at least one output port disposed in an upward direction to enable optimum routing of the one or more output hoses to at least one of the front wheel brake and the rear wheel brake.

[00042] It is a feature that in one embodiment the pressure control device includes at least one input port disposed in upward direction in proximity to the at

least one brake lever mounted to the handle bar assembly thereby providing optimum routing of one or more input hoses when required. Also, at least one output port is disposed in a downward direction in proximity to the front wheel brake thereby providing optimum cable routing when required.

- 5 [00043] It is an advantage of the present subject matter that the pressure control device is mounted in proximity to the handle bar assembly and to the front wheel brake thereby minimizing overall tubing length. It is a further advantage that the cost of the system is reduced.

[00044] It is yet another aspect that the pressure control device being mounted
10 to the front facing side of the head tube is enclosed by a front panel. The pressure control device is mounted to the vehicle by securing it from the external parameters and accidental damage. Moreover, it is yet another advantage that servicing for air bleeding can be performed with minimal parts removal, like removal of the front panel only, thereby improving the serviceability.

- 15 [00045] The aspects of the present subject matter is not limited to two-wheeled vehicle used herein and predominantly includes motor vehicles with a saddle ride-type layout that are similar to the two wheeled vehicles.

[00046] Moreover, the current subject matter is applicable to a three-wheeled vehicle comprising a front wheel and a pair of rear wheels or vice versa, wherein
20 the three-wheeled vehicle includes a frame assembly with a head tube.

[00047] These and other advantages of the present subject matter would be described in greater detail in conjunction with the figures in the following description.

- [00048] Fig. 1 (a) illustrates a left side view of an exemplary motor vehicle 100,
25 in accordance with an embodiment of the present subject matter. The motor vehicle 100 has a frame assembly 105 having a step-through type layout. A handlebar assembly 110 is mounted to a steering shaft (not shown). The steering shaft is rotatably supported by the frame assembly 105 whereby the handle bar assembly 110 is rotatable about the frame assembly 105 to steer the vehicle. A
30 front wheel 115 is connected to the handle bar assembly 110 through one or more front suspension(s) 120. A power unit 125 is swingably mounted to the frame

assembly 105. The power unit includes at least one of an internal combustion engine and a traction motor. Further, the power unit 125 includes a transmission system (not shown) including an automatic transmission, a continuously variable transmission, or a fixed ratio transmission.

5 [00049] Further, the power unit 125 is coupled to a rear wheel 130 through the transmission system. Also, the rear wheel 130 is connected to the frame assembly 105 through one or more rear suspension(s) 135. A seat assembly 165 is disposed upwardly of the power unit 125 and is supported by the frame assembly 105. A storage compartment (not shown) is provided below the seat assembly 165 and is
10 also supported by the frame assembly 105. The utility box is accessible in an open condition of the seat assembly 165.

[00050] Furthermore, the vehicle 100 is provided with plurality of panels 140A, 140B, and 140C that are mounted to the frame assembly 105 and covering the vehicle parts. Especially, a front panel 140A is disposed forward to the head tube
15 105A. In the present embodiment, the vehicle includes a floorboard 145 disposed at a step-through space ST defined by the frame assembly 105. The user can operate the vehicle by resting feet on the floorboard 145, in a seated position. A front fender 150 is covering at least a portion of the front wheel 110. In the present embodiment, the front fender 150 is integrated with a front panel 140A of
20 the vehicle 100. A rear fender 155 covers at least a portion of the rear wheel 130. The front fender 150 and the rear fender 155 prevent splashing of dirt on to the vehicle parts and away from the vehicle 100. A fuel tank (not shown) is supported by the frame assembly 105 and is functionally coupled to the power unit 125. The vehicle 100 comprises of plurality of electrical/electronic components including a
25 headlight 160A, a tail light 160B, a battery (not shown), a transistor controlled ignition (TCI) unit (not shown), an alternator (not shown), a starter motor (not shown).

[00051] Fig. 1 (b) illustrates a right side perspective view of the frame assembly of the vehicle employed/provided with vehicle parts, in accordance with the
30 embodiment as depicted in Fig. 1 (a). The frame assembly 105 includes a head tube 105A, a main tube 105B extending rearward from the head tube 105A, and one or more rear tubes 105C extending inclinedly rearward from a rear portion of

the main tube 105B. In the depicted embodiment, the main tube 105B extends rearwardly downward from the head tube 105A defining the step-through space ST. The vehicle 100 is employed with a front wheel brake 205 and a rear wheel brake 210 functionally connected to the front wheel 115 and the rear wheel 130, respectively. In an embodiment, the front wheel brake 205 is a hydraulically operated disc brake 205 and the rear wheel brake 210 is a hydraulically operated disc brake 210. However, the vehicle may be employed with hydraulically operated mechanical brakes like a drum brake.

[00052] Further, the vehicle 100 includes a synchronized braking system 200 that is provided with a synchronous brake lever 220 mounted to the handle bar assembly 110 of the vehicle 100 in the present implementation. Also, a front wheel brake lever 215 is mounted to the handle bar assembly 110, which functions as an independent brake lever. In a preferred embodiment, the front wheel brake lever 215 is provided on a right side of the handle bar 100 and the synchronous brake lever 220 is provided on the left side of the handle bar 100. A rider may actuate the front brake lever 215 to apply the front wheel brake 205. Similarly, actuation of the synchronous brake lever 220 applies both the front wheel brake 205 and the rear wheel brake 210. The disc brake 210 is provided with a disc 210D affixed to the rear wheel 130 and caliper(s) 210C that are functionally coupled to the disc 210D and fixed at a swing arm or the like. The caliper is supported by the front suspension 120 in case of the disc brake 205 employed on the front wheel.

[00053] The front brake lever 215 is coupled to a master cylinder 215M, which is connected to the brake caliper(s) of the front wheel brake 205 through a first input hose 225 (shown in Fig. 1 (c)). Upon operation of the front brake lever 215, pressure is generated in the master cylinder 215M that is transferred to the brake calipers (not shown) of the front wheel brake 205 through the first input hose 225. Further, the synchronous brake lever 220 is coupled to another master cylinder 220M, which is connected to a pressure distribution device 300 that is connected to the front brake caliper and the rear brake caliper 210C through a front brake-output hose 240 and a rear brake-output hose 235, respectively. The rear brake-output hose is referred to as first output hose 235 and the front brake-output hose

240 is referred to as second output hose 240 for brevity. The pressure distribution device 300 is a pressure control device. Hereinafter, the terms "pressure control device" and the "pressure distribution device" are interchangeably used. Therefore, operation of the synchronous brake lever 220 generates pressure in the master cylinder 215M that is transferred to the pressure control device 300. From the pressure control device 300, the pressure is distributed to the front wheel brake 205 and the rear wheel brake 210 at a pre-determined ratio. Also, the pressure distribution device 300 is disposed in proximity to the head tube 105A of the vehicle 100. In a preferred implementation, the pressure distribution device 300 is disposed adjacently ahead of the head tube 105A and is secured to the head tube 105A.

[00054] Fig. 1 (c) depicts an enlarged view of the front portion of the vehicle 100, in accordance with the embodiment depicted in Fig. 1 (b). The pressure distribution device 300 is affixed to the head tube 105A and is preferably positioned at the front facing side of the head tube 105A. In the present embodiment, the pressure distribution device 300 is functionally connected to the front brake lever 215 and the synchronous brake lever 220, which is specifically to a front brake input port 302 and to a synchronous brake input port 301 of the pressure control device 300, respectively. Also, the pressure control device 300 includes a front brake output port 303 and a rear brake output 304 (the input port(s) 301, 302 and the output port(s) 303, 304 are depicted in Fig. 1 (d)). Operation of the front brake lever 215 will generate pressure in the master cylinder 215M, which is functionally coupled to the front brake lever 215, is transferred to the front brake input port of the pressure control device 300 through the first input hose 225. This pressure is transferred to the front wheel brake 205 through a second output hose 240 thereby actuating the front wheel brake 205. The second output hose 240 extends from the pressure control device 300 towards the front wheel brake 205. Similarly, operation of the synchronous brake lever 220 results in generation of pressure in the master cylinder 220M functionally coupled to synchronous brake lever 220. The pressure from the master cylinder 220M is transferred to the pressure control device 300 through a second input hose 230, which is a synchronous brake input hose 230, connected to the pressure

control device 300. Then, the pressure from pressure control device 300 is transferred to both the front wheel brake 205 and the rear wheel brake 210 through the second output hose 240 and the first output hose 235 connected to the front brake output and the rear brake output, respectively. The first output hose
5 235 extends rearward from the pressure control device 300 and is supported by at least a portion of the main tube 105B. Further, the first output hose 235 comprises a rigid hose portion 235R that is provided from the main tube 105B towards a floorboard portion 145 of the vehicle 100.

[00055] During operation of the brake lever 215, 220, force is exerted on an
10 actuation rod that displaces the piston(s) in the master cylinder 215M. The displacement of the piston causes an increase in the pressure of the entire system, forcing fluid through the one or more hoses. During operation of the front brake lever 215, the increase in pressure is transferred to the front brake input port of the pressure control device 300 through the second input hose. In the present
15 embodiment, the front brake input of the pressure control device 300 communicates directly with the front brake output thereby actuating the front wheel brake 205.

[00056] Similarly, operation of the synchronous brake lever transfers increase in pressure to the synchronous brake input of the pressure control device 300. This
20 change in pressure is displaces a piston provided in the pressure control device 300 thereby effecting a change in pressure through the front brake output and the rear brake output of the pressure control device 300, thereby actuating both the front wheel brake and rear wheel brake. Therefore, the pressure control device 300 disposed in the front portion vehicle 100 and in proximity of the head tube
25 105A provides optimum routing of the hose(s) to the at least one brake lever 215, 220 mounted to the handle bar assembly 110 and to the front wheel brake 205 being substantially equidistant therebetween. The pressure control device 300 being at least approximately equidistant from brake levers 215 & 200 and from the front wheel brake 205 requiring optimum length of the hose(s) making it cost
30 effective. Also, number of bends required for routing the hose(s) is minimized.

[00057] , in one embodiment, the front brake system may be independent of the synchronous brake system.

[00058] The pressure control device 300 is connected to the front brake lever 215, to the synchronous brake lever 220, the front wheel brake 205, and the rear wheel brake 210 through plurality of flexible hoses 225, 230, 235, 240. Especially, the handle bar assembly 110 supporting the front brake lever 215 and
5 the rear brake lever 220 is a rotating member and as the pressure control device 300 disposed below the handle bar assembly 110 is rigidly and securely fixed to the frame assembly 105 without adding any weight on the moving/rotating members like the front wheel 115 or the rear wheel 120. Also, the position of the pressure control device 300 with reference to the front wheel brake 205 is varying
10 due to the presence of front suspension 120 that compresses and expands with the road conditions. Thus, the one or more hoses are made of flexible material enable avoidance of damage of hoses. In addition, the length of the hose is substantially greater than the distance between the points of connection to accommodate the aforementioned variations.

[00059] Provision of the pressure control device 300 at the head tube 105A facilitates use of optimum length of hose 240 for connecting the pressure control device 300 to the front brake lever 215 and the rear brake lever 220. Also, the pressure control device 300 is at optimum distance and between the handle bar assembly 110 and the front wheel brake 205 thereby providing optimum hose
20 routing. Further, the plurality of hoses is connected to the pressure control device 300 through intermediate connector(s) 305A, 305B, 305C, 305D (shown in Fig. 1 (f)).

[00060] Fig. 1 (d) depicts an exploded view of the pressure control device 300 of the braking system employed on the vehicle, in accordance with the embodiment depicted in Fig. 1 (b). The frame assembly 105 is affixed with a mounting member 105M that is welded to the frame assembly 105. In other embodiment, the mounting member 105M is affixed to the frame assembly 105. In the present embodiment, the mounting member 105M is having a U-shaped profile with an opening of the U-shape facing the frame assembly 105. Preferably,
30 the mounting member 105M is affixed to the front facing side of the head tube 105A through the ends of the mounting member 105M. The U-shaped profile provides clearance between a peripheral surface of the head tube 105A and the

mounting member 105M thereby enabling ease of assembly of the pressure control device 300 using fasteners. Further, the mounting member 105M is provided with one or more mounting point(s) for securing the pressure control device 300 to the mounting member 105M, wherein in one embodiment the mounting point(s) are apertures. Moreover, the mounting point(s) are provided so as to align with one or more mounting point(s) provided on the pressure control device 300, thereby enabling mounting of the pressure control device 300 in a desired orientation.

[00061] Further, the first input hose 225, the second input hose 230, and the second output hose 240 are provided with lengths with a ratio of maximum length to minimum length being in the range of 0.8 to 1.2 whereby the vehicle 100 with the pressure control device 300 provides optimum hose length.

[00062] In the present implementation, the pressure control device 300 is securely mounted to the frame assembly 105 in proximity to the head tube 105A in at least one orientation. In the depicted embodiment, the pressure control device is disposed in a first orientation with a long axis L-L thereof is substantially parallel to a lateral direction RH-LH of the vehicle 100. The pressure control device 300 includes at least one input port 301, 302 disposed in a downward direction DW to enable smooth curved routing of the input hoses 225, 230 connecting to at least one brake lever 215, 220 to the pressure control device 300. The pressure control device 300 includes at least one output port 303, 304 disposed in an upward direction UP to enable optimum routing of the one or more hoses 303, 304 in to at least one of the front wheel brake 205 and the rear wheel brake 210.

[00063] The pressure control device 300 is disposed behind the front panel 140A and above a front fender 150. The front panel 140A is covering at least a portion of the pressure control device 300, and the front panel 140A is supported by an additional bracket 106 mounted to the head tube 105A. The additional bracket 106 is extending in forward direction F beyond a forward most portion of the pressure control device 300. Also, the front panel 140A in removed condition provides access to the pressure control device 300 and also hoses connected thereto.

[00064] The pressure control device 300 can be disposed in a second orientation with the long axis L-L thereof disposed substantially parallel to the longitudinal direction F-R of the vehicle 100. Therefore, head tube 105A may support an auxiliary power source (not shown) or electrical components like horn or head lamp in the front facing side of head tube 105A and the pressure control device 300 is disposed towards one lateral side RH or LH of the frame assembly 105 and in proximity to the head tube 105A to provide optimum routing of the hose(s).

[00065] Furthermore, an orientation bracket 400 is provided that abuts against the pressure control device 300. One or more fasteners F are used to secure the orientation bracket 400 and the pressure control device 300 to the mounting member 105M. The orientation bracket 400 is alternatively referred to as a poka-yoke bracket 400 herein. However, in another embodiment, the poka-yoke bracket 400 is secured to the pressure control device 300 by snap-fit, a clip-on type fit, or any known securing means.

[00066] In the present implementation, the intermediate connector(s) are banjo joint(s) that comprises of a perforated hollow bolt and spherical union for fluid transfer. Through the hollow bolt the hose is secured to the at least one of the input(s) and output(s) of the pressure control device 300. However, there is a possibility of wrong assembly due to the use of plurality of hoses and their respective banjo joint. Thus, a poka-yoke bracket 400 is provided that is secured to the pressure control device 300. The poka-yoke bracket 400 works in conjunction with banjo joints. Fig. 1 (e) depicts an isometric view of the poka-yoke bracket 400, in accordance with the present embodiment.

[00067] The poka-yoke bracket 400 includes plurality of arm members 405A, 405B, 405C, 405D. The number of arm members 405A, 405B, 405C, 405D provided is equivalent to the number of input and number of output ports being provided on the pressure control device 300. In the depicted embodiment, the poka-yoke bracket 400 is provided with four arm members 405A, 405B, 405C, 405D. The arm members are supported by a base portion (not shown). The base portion 410 is provided with mounting points 415 that align with the mounting points provided on the pressure control device 300 and the mounting member

105M. Each arm member of the poka-yoke bracket 400 extends towards each of the input ports 301, 302 and each of the output ports 303, 304 of the pressure control device 300. Also, each of the arm members 405A, 405B, 405C, 405D is provided with a receiving portion R. In the present embodiment, the receiving
5 portion R is formed by a U-shaped cutout. The arm and the receiving portion are oriented in a specific direction so as to receive an intermediate connector 305A, 305B, 305C, 305D (shown in Fig. 1 (e)) that are provided with a with a specific orientation. Therefore, the arm members 405A, 405B, 405C, 405D are provided to enable reception of specific intermediate connectors 305A, 305B, 305C, 305D
10 like banjo joint at a specific port of the pressure control device 300. Hence, correct mounting of the banjo joints is achieved thereby eliminating functional failure due to wrong assembly thereby providing easy and fool proof assembly.

[00068] Fig. 1 (f) depicts an exploded view of the pressure control device 300 assembly, in accordance with the embodiment depicted in Fig. 1 (c). In the present
15 embodiment, four banjo joints 305A, 305B, 305C, 305D that function as intermediate connectors are secured to ends of the hoses 225, 230, 235, and 240, respectively. According to the present embodiment, the pressure control device 300 is provided with a front brake input port 301 and a synchronous brake input port 302 positioned on a downward portion of the pressure control device 300.
20 Similarly, a front brake output port 303 and a rear brake output port 304 are provided in the upward direction/portion UP of the pressure control device 300. A first banjo joint 305A connects the synchronous brake lever 220 to the pressure control device 300, and a second banjo joint 305B connects the front brake lever 215 to the pressure control device 300. Further, the input ports are provided on
25 opposite sides to the position the brake levers are disposed to provide a smooth and large curvature. Similarly, a third banjo joint 305C and a fourth banjo joint 305D connect the rear wheel brake 210 and the front wheel brake 205 to the pressure control device 300, respectively. Moreover, the banjo joints 305A, 305B, 305C, 305D enable ease of assembly of the connection without affecting the hoses
30 225, 230, 235 and 240. The banjo joints being made of rigid material like metal enables hoses to be retained in a desired orientation. Additionally, the present subject matter with the pressure control device 300 disposed in proximity to the

head tube 105A provides flexibility to change the position of the ports depending on the vehicle layout requirements.

5 [00069] The arm members 405A, 405B, 405C, and 405D (as shown in Fig. 1 (e)) of the poka-yoke bracket 400 extend towards the aforementioned port(s), and only one banjo joint of the plurality of banjo joints abuts against the receiving
10 portion(s) R of the banjo joint(s) 305A, 305B, 305C, and 305D. Moreover, this enables use of same pressure control device 300 in a different vehicle layout by merely changing the poka-yoke bracket 400 in accordance to the desired layout. Also, the fasteners F1, F2 securely hold the pressure control device 300 and the
15 poka-yoke bracket 400 to the mounting member 105M.

[00070] Also, provision of the orientation bracket 400 independent of the pressure control device 300 enables use of the same pressure control device 300 for different vehicle layouts with mere modification of the orientation bracket 400 according to the pressure control device 300 orientation.

15 [00071] It is to be understood that the aspects of the embodiments are not necessarily limited to the features described herein. Many modifications and variations of the present subject matter are possible in the light of above disclosure. Therefore, within the scope of claims of the present subject matter, the present disclosure may be practiced other than as specifically described.

We claim:

1. A motor vehicle (100) comprising a synchronized braking system (200),
said vehicle (100) comprising:

5 a frame assembly (105) comprising a head tube (105A) disposed in
a front portion thereof;

a front wheel brake (205) capable of applying braking forces to at
least one front wheel (115), said at least one front wheel (115) rotatable
about said head tube (105A) to enable steering of said vehicle (100);

10 a rear wheel brake (210) capable of applying braking forces to at
least one rear wheel (130); and

a pressure control device (300) of said synchronized braking
system (200) is functionally connected to said rear wheel brake (210)
through a first output hose (235) and is functionally connected to said front
wheel brake (205) through a second output hose (240), said pressure
15 control device (300) capable of being actuated by a synchronous brake
lever (220), said pressure control device (300) is securely disposed in
proximity to said head tube (105A) of the frame assembly (105).

2. The motor vehicle (100) as claimed in claim 1, wherein said pressure
control device (300) is substantially equidistant from at least one brake lever (215,
20 220) mounted to a handle bar assembly (110) rotatable about said head tube
(105A) and from said front wheel brake (205).

3. The motor vehicle (100) as claimed in claim 1, wherein said pressure
control device (300) is securely disposed ahead of said head tube (105A), and said
pressure control device (300) is having a long axis (L-L₁) disposed substantially in
25 a first orientation being substantially parallel to a lateral direction (RH-LH) of
said motor vehicle (100).

4. The motor vehicle (100) as claimed in claim 1, wherein said pressure
control device (300) is securely disposed towards one lateral side (RH, LH) of
said head tube (105A), and said pressure control device (300) is having a long

axis (L-L₁) disposed in a second orientation being substantially parallel to a longitudinal direction (F-R) of said motor vehicle (100).

5 5. The motor vehicle (100) as claimed in claim 1, 3 or 4, wherein said pressure control device (300) is securely mounted to said frame assembly (105) in
10 proximity to said head tube (105A) in at least one of said first orientation or said second orientation, and said pressure control device (300) includes at least one input port (301, 302) disposed in a downward direction (DW) to enable smooth curved routing of one or more input hoses (225, 230) connecting said at least one brake lever (215, 220) thereto and said pressure control device (300) includes at
15 least one output port (303, 304) disposed in an upward (UP) direction to enable optimum routing of said one or more output hoses (235, 240) to at least one of said front wheel brake (205) and said rear wheel brake (210).

6. The motor vehicle (100) as claimed in claim 1, 3 or 4, wherein said pressure control device (300) is securely mounted to said frame assembly (105) in
15 proximity to said head tube (105A) in at least one of said first orientation and said second orientation, and said pressure control device (300) includes at least one input port (301, 302) disposed in an upward direction (UP) in proximity to said at least one brake lever (215, 220) mounted to said handle bar assembly (110) and includes at least one output port (303, 304) disposed in a downward direction
20 (DW) in proximity to said front wheel brake (205).

7. The motor vehicle (100) as claimed in claim 1 or 3, wherein said pressure control device (300) is mounted to a front facing side of head tube (105A) and is disposed below said handle bar assembly (110) and is above said front wheel brake (120) therebetween, whereby said pressure control device (300) is in
25 proximity to said synchronous brake lever (220) mounted to said handle bar assembly (110) and said front wheel brake (205).

8. The motor vehicle (100) as claimed in claim 1, wherein said pressure control device (300) is affixed to a mounting member (105M) secured to said frame assembly (105), said mounting member (105M) is having a U-shaped
30 profile with clearance to enables fastening of said pressure control device (300), and said mounting member (105M) includes one or more mounting point(s) provided to align with one or more mounting point(s) provided on the pressure

control device (300) thereby enabling mounting of the pressure control device (300) in a desired orientation.

9. The motor vehicle (100) as claimed in claim 1, wherein said pressure control device (300) is disposed substantially at along a lateral centre of the vehicle (100) whereby a centre of gravity of the pressure control device (300) and a centre of gravity of the vehicle (100) are in line providing lateral balance.

10. The motor vehicle (100) as claimed in claim 1, wherein said pressure control device (300) is disposed at a lateral offset from a lateral centre of the vehicle (100) whereby the pressure control device (300) balances a centre of the gravity of the vehicle (100).

11. The motor vehicle (100) as claimed in claim 1, wherein said pressure control device (300) is connected to said at least one brake lever (215, 220) through a first input hose (225) and a second input hose (230) and said pressure control device (300) is connected to said front wheel brake (205) through a second hose (240), and wherein said a ratio of maximum length to minimum length between the first input hose (255), the second input hose (230), and the second output hose (240) being in the range of 0.8 to 1.2.

12. The motor vehicle (100) as claimed in claim 1, wherein said pressure control device (300) is disposed behind a front panel (140A) and above a front fender (150), said front panel (140A) is covering at least a portion of the pressure control device (300), and said front panel (140A) is supported by an additional bracket (106) mounted to said head tube (105A) extending in forward direction (F) beyond a forward most portion of said pressure control device (300).

13. The two-wheeled vehicle (100) as claimed in claim 1, wherein said pressure control device (300) is connected to a front brake lever (215) for application of braking force independently to the front wheel brake (205) and said front brake lever (215) is mounted to said handle bar assembly (110) of said vehicle (100).

14. The two-wheeled vehicle (100) as claimed in claim 1, wherein said motor vehicle (100) includes an orientation bracket (400) disposed adjacent to said pressure control device (300) and is adapted to work with said pressure control device (300) to enable fool proof fitment of one or more intermediate connector(s)

(305A, 305B, 305C, 305D) connecting one or more hose(s) (225, 230, 235, 240) to said pressure control device (300), and wherein said orientation bracket (400) includes one or more arm(s) (405A, 405B, 405C, 405D) and each arm of the one or more arm members (405A, 405B, 405C, 405D) includes a receiving portion (R) capable of receiving only specific intermediate connector of said one or more intermediate connector(s) (305A, 305B, 305C, 305D) thereby enabling said fool proof fitment and said arm member (405A, 405B, 405C, 405D) retains the intermediate connectors (405A, 405B, 405C, 405D) in a specific orientation thereby retaining a desired orientation of the one or more hoses (225, 230, 235, 240).

15 15. A orientation bracket (400) adapted to work with a pressure control device (300) of a synchronized braking system (200), said orientation bracket (400) comprising:

a base portion (410); and

15 one ore more arm members (405A, 405B, 405C, 405D) supported by said base portion (410),

wherein

said one or more arm members (405A, 405B, 405C, 405D) extend towards one or more input port(s) (301, 302) and towards one or more output port(s) (303, 304) of said pressure control device (300), and one or more arm of said one or more arm members (405A, 405B, 405C, 405D) includes a receiving portion (R) capable of receiving only a one or more specific intermediate connector (305A, 305B, 305C, 305D) connecting said one or more hose(s) (224, 230, 235, 240) to said pressure control device (300) thereof.

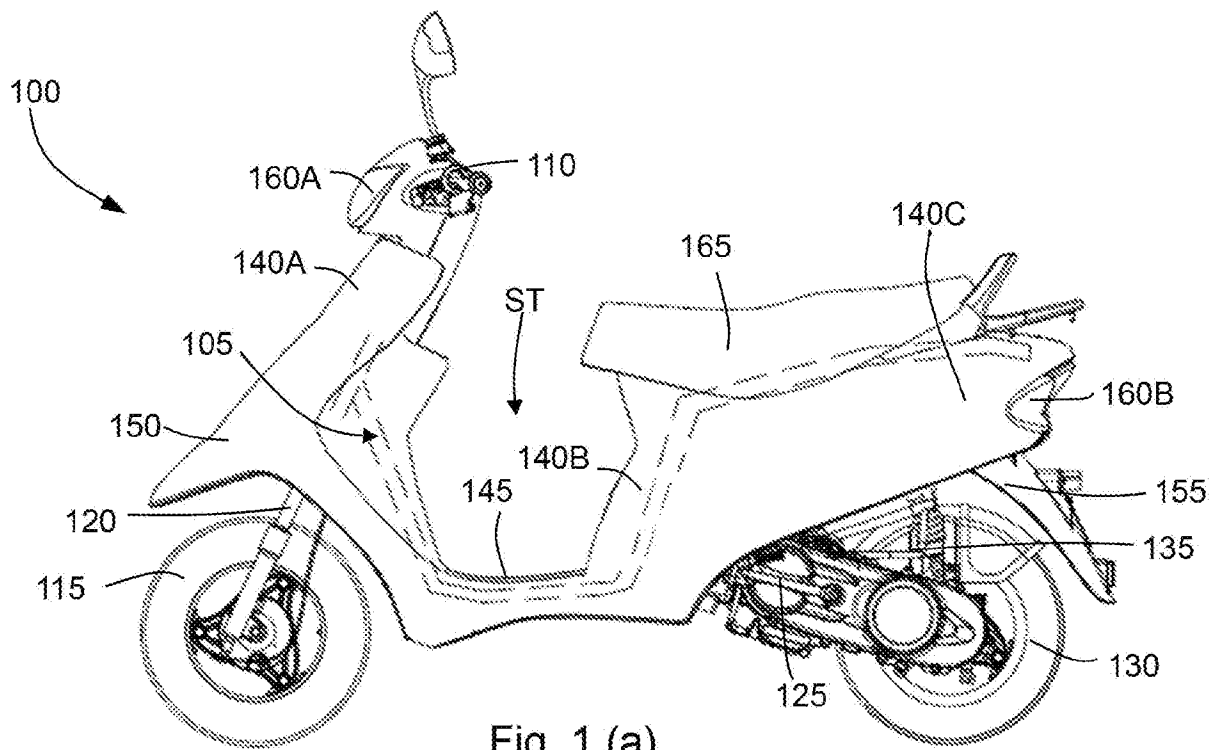
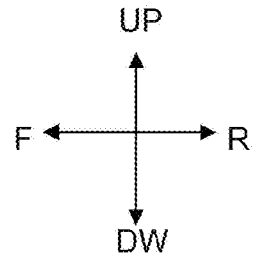

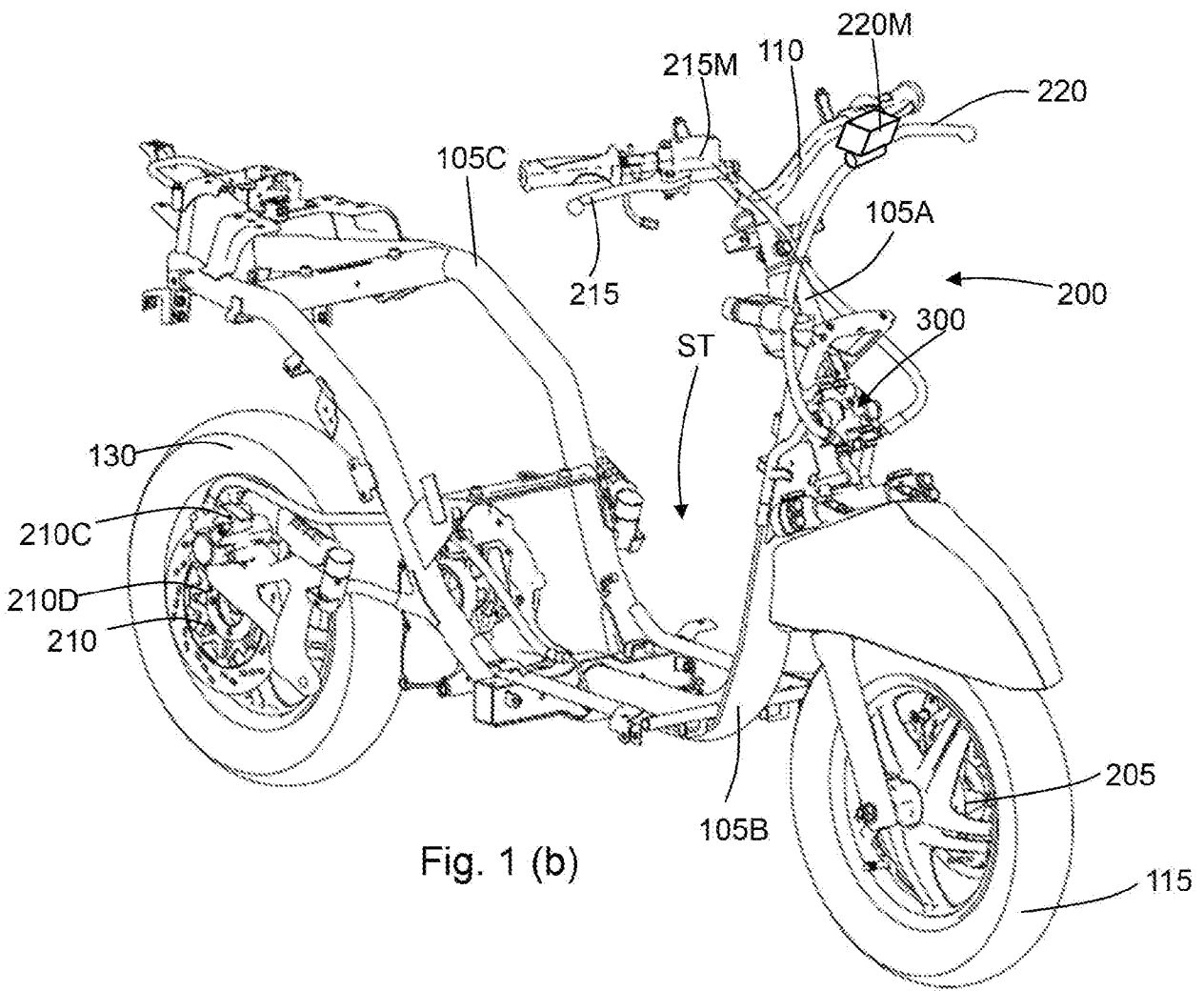
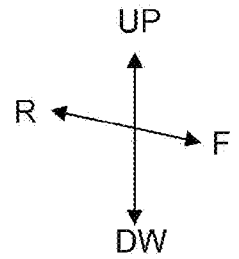

Fig. 1 (b)

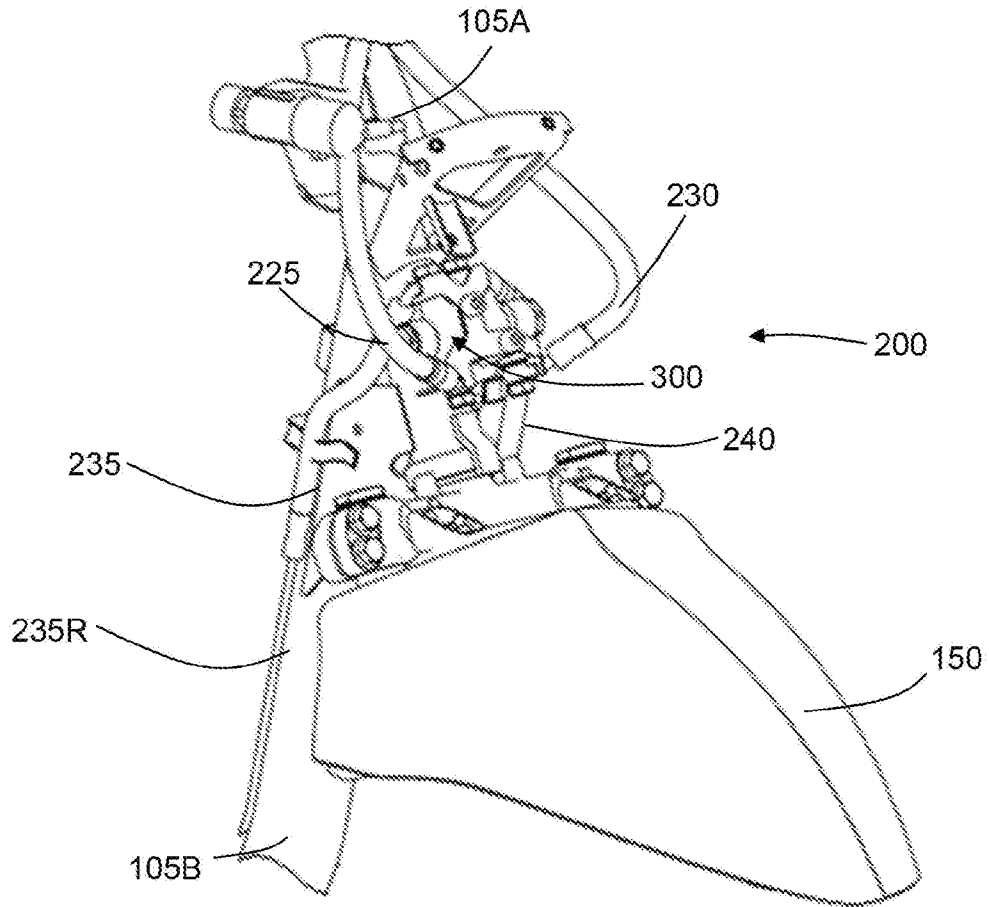
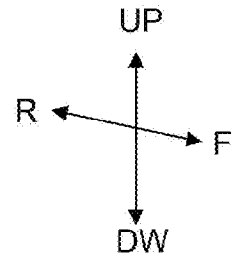

Fig. 1 (c)

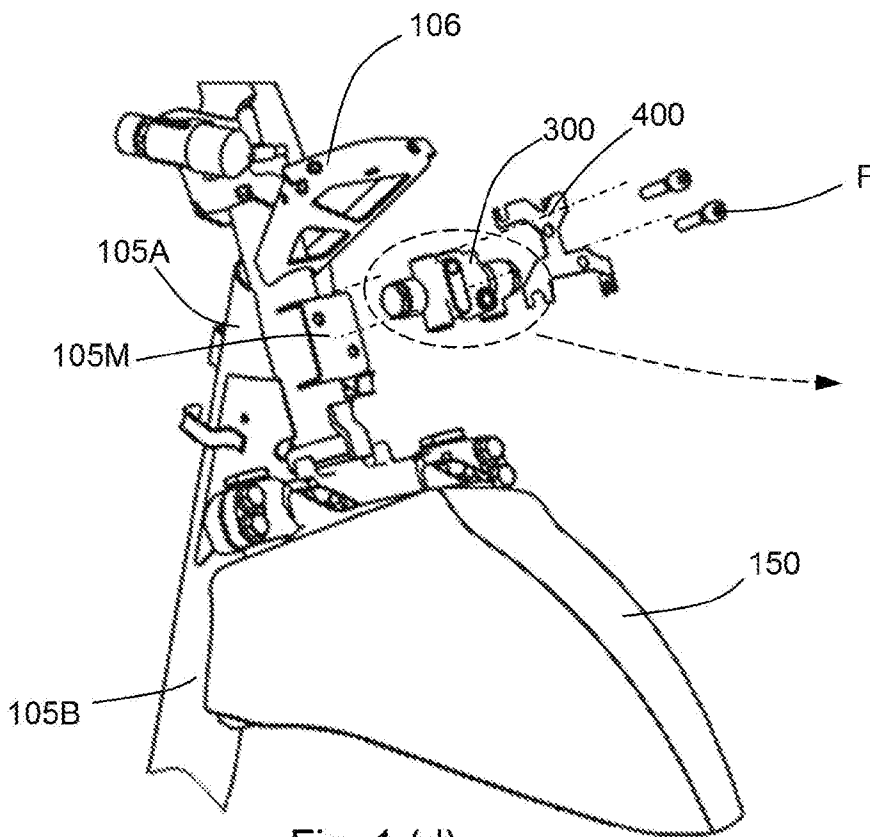
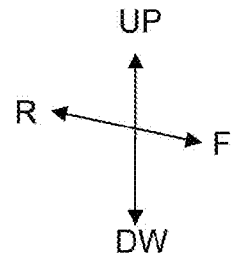
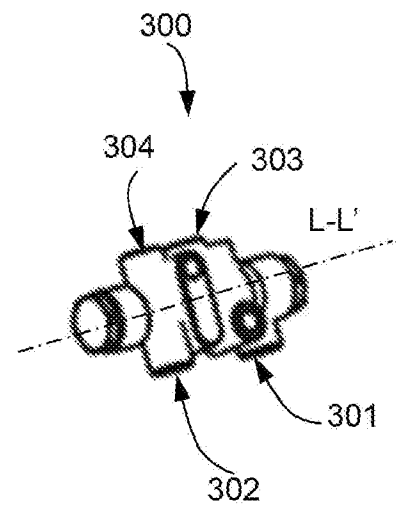
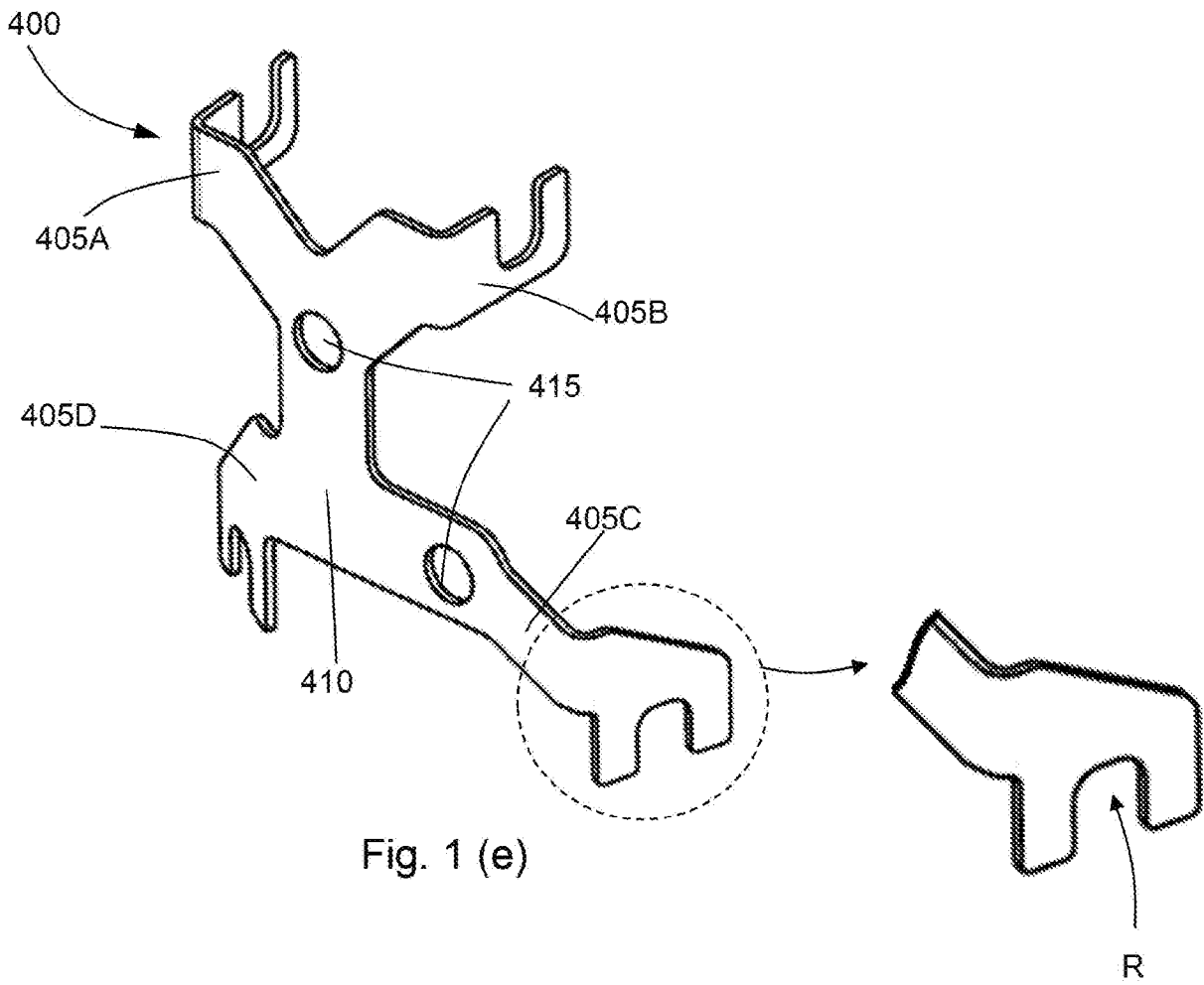

Fig. 1 (d)





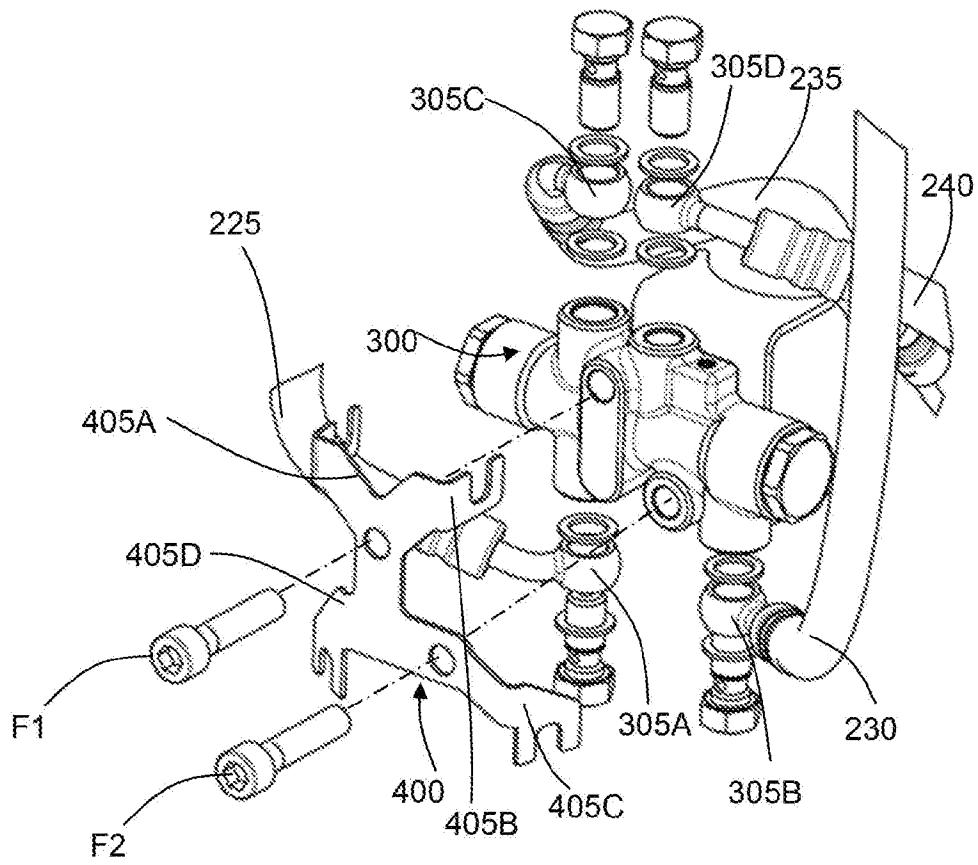

Fig. 1 (f)

INTERNATIONAL SEARCH REPORT

International application No.
PCT/IB2017/057378

A. CLASSIFICATION OF SUBJECT MATTER

B62L3/08, B62L3/02, B60T8/26, B60T1/08, F16L27/093, F16L41/04 Version=2018.01

According to International Patent Classification (IPC) or to both national classification and IPC

B. FIELDS SEARCHED

Minimum documentation searched (classification system followed by classification symbols)

B62L, B60T, F16L

Documentation searched other than minimum documentation to the extent that such documents are included in the fields searched

Electronic data base consulted during the international search (name of data base and, where practicable, search terms used)

Patseer, IPO Internal Database

C. DOCUMENTS CONSIDERED TO BE RELEVANT

Category*	Citation of document, with indication, where appropriate, of the relevant passages	Relevant to claim No.
Y	WO2016113756 A1 (TVS MOTOR COMPANY LIMITED; 21 Jul 2016) Abstract; Para [0033], [0037]-[0039]; Fig. 1b.	1-15
Y	US20100052416 A1 (AIBA et al.; 04 Mar 2010) Abstract; Para [0013], [0016], [0044], [0056], [0065]; Figs. 1,2.	1-15
Y	US6688440 B2 (SHIMANO, INC.; 10 Feb 2004) Abstract; Column 1: Lines 10-42; Column 3: Lines 50-62; Figs. 6-7.	1-15

Further documents are listed in the continuation of Box C. See patent family annex.

* Special categories of cited documents:

"A" document defining the general state of the art which is not considered to be of particular relevance

"E" earlier application or patent but published on or after the international filing date

"L" document which may throw doubts on priority claim(s) or which is cited to establish the publication date of another citation or other special reason (as specified)

"O" document referring to an oral disclosure, use, exhibition or other means

"P" document published prior to the international filing date but later than the priority date claimed

"T" later document published after the international filing date or priority date and not in conflict with the application but cited to understand the principle or theory underlying the invention

"X" document of particular relevance; the claimed invention cannot be considered novel or cannot be considered to involve an inventive step when the document is taken alone

"Y" document of particular relevance; the claimed invention cannot be considered to involve an inventive step when the document is combined with one or more other such documents, such combination being obvious to a person skilled in the art

"&" document member of the same patent family

Date of the actual completion of the international search

08-02-2018

Date of mailing of the international search report

08-02-2018

Name and mailing address of the ISA/

Indian Patent Office
Plot No.32, Sector 14, Dwarka, New Delhi-110075
Facsimile No.

Authorized officer

Divyanshu Mishra

Telephone No. +91-1125300200

INTERNATIONAL SEARCH REPORT
Information on patent family members

International application No.
PCT/IB2017/057378

Citation	Pub.Date	Family	Pub.Date		
US 2010052416 A1	04-03-2010	IN 269802 A1	13-11-2015		
		IN CHE200902009 A	26-03-2010		
		JP 5227872 B2	03-07-2013		
		JP 2010076742 A	08-04-2010		
		CN 101659308 B	01-05-2013		
		CN 101659308 A	03-03-2010		
		IT 1395261 B1	05-09-2012		
		IT TO20090573 A1	28-02-2010		
		VN 20942 A	25-09-2009		
		US 6688440 B2	10-02-2004	CN 1281455 C	25-10-2006
				CN 1443680 A	24-09-2003
DE 60301896 T2	11-05-2006				
DE 60301896 D1	02-03-2006				
AT 307053 T	15-11-2005				
EP 1346909 B1	19-10-2005				
EP 1346909 A1	24-09-2003				
TW I222415 B	21-10-2004				
TW 200303838 A	16-09-2003				
US 2003173160 A1	18-09-2003				
JP 2003261086 A	16-09-2003				