

G. J. LJUNGGREN.
 CLOSURE LOCKING MEANS.
 APPLICATION FILED DEC. 9, 1909.

1,002,287.

Patented Sept. 5, 1911.

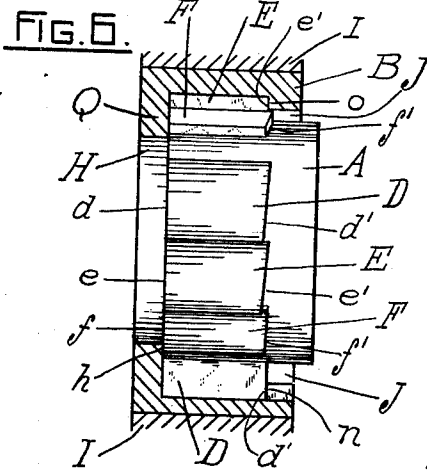
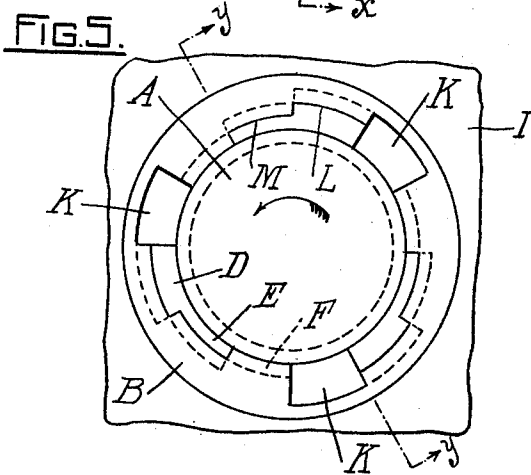
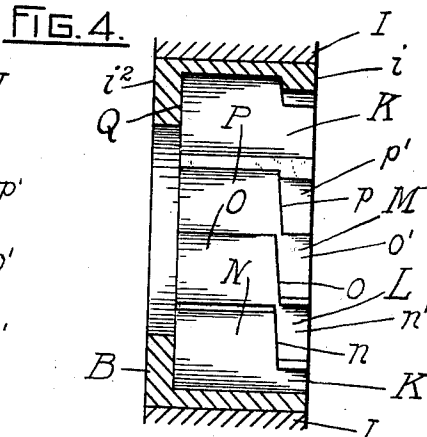
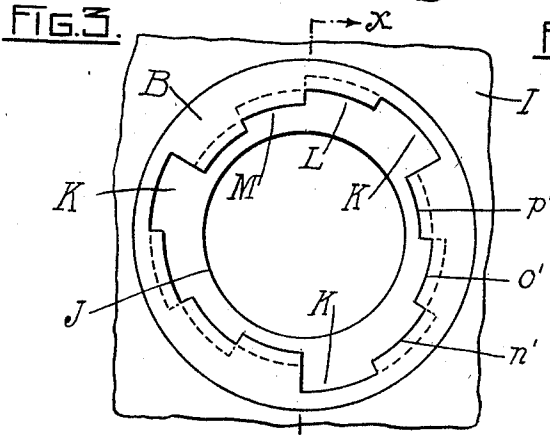
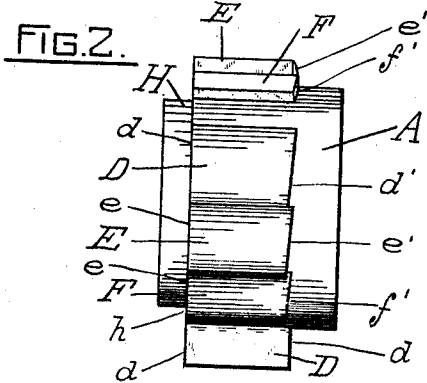
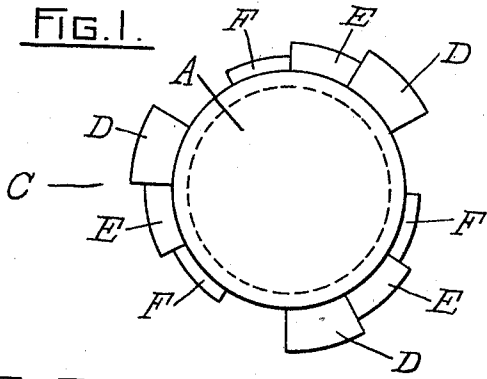

WITNESSES.
Albert G. Puczmanski,
George H. McLaughlin,

INVENTOR.
Carl J. Ljunggren
 By *Horatio E. Bellows*
ATTORNEY.

UNITED STATES PATENT OFFICE.

CARL J. LJUNGGREN, OF PROVIDENCE, RHODE ISLAND.

CLOSURE-LOCKING MEANS.

1,002,287.

Specification of Letters Patent.

Patented Sept. 5, 1911.

Application filed December 9, 1909. Serial No. 532,211.

To all whom it may concern:

Be it known that I, CARL J. LJUNGGREN, a subject of the King of Sweden, residing at Providence, in the county of Providence and State of Rhode Island, have invented certain new and useful Improvements in Closure-Locking Means, of which the following is a specification.

My invention relates to closure locking means adapted for use in a variety of structures such as vault doors, gun breeches, port holes, man holes and the like.

The objects of the invention are to avoid the weakening effects attendant upon the employment of screw threads in structures of this character; to increase the pressure resisting power of the closure member while decreasing its length and weight; to make the parts impervious to explosives to render the parts accessible for cleaning and readily operative; to prevent play, and the premature longitudinal dislodgment of the closure member when partially engaged; and to facilitate the seating of the same and render the parts inaccessible after engagement.

Further objects are to decrease the number of parts and adapt the same for inexpensive and easy manufacture.

To the above ends essentially the invention consists in the novel construction, arrangement, and correlation of the parts hereinafter set forth and falling within the scope of the appended claims.

In the accompanying drawings which constitute a part of this specification and in which like letters of reference indicate like parts throughout the views,—Figures 1 and 2 are rear and side elevations respectively of the novel closure member, Fig. 3, a rear end elevation of the stationary member, Fig. 4, a section of the same on line *x x* of Fig. 3, Fig. 5, a rear elevation of the closure member and stationary member interlocked, and Fig. 6, a section on line *y y* of Fig. 5, showing the closure member in side elevation.

My invention is shown in this instance embodied in a closure member A which is either a plug or door, cooperating with a stationary member B, which is either a breech or jamb. The mechanism for supporting, inserting, rotating, and withdrawing the member A forms no part of the present invention, and being well known in the art is not herein illustrated.

In detail the closure member A is cylindrical in general outline, and has a plurality of smooth longitudinally disposed segments C upon its intermediate portion interspaced equidistant from each other. Each segment comprises a plurality of radially graduated longitudinally disposed stepped portions D, E, F, of equal length whose front end faces *d, e, f*, respectively are in the same plane, and whose rear ends *d', e', f'*, respectively are each transversely inclined. In the construction illustrated the forward end of the member A is of reduced diameter as at H to form a shoulder *h*.

The receiving or stationary member is in the present instance a collar B, fixed in any suitable manner in a wall I. The collar, whose inner face is *i*, and whose exterior face is *i'*, incloses a substantially cylindrical orifice J having a circumferential series of radially graduated longitudinally disposed entrance channels K, L, M, all of equal length, and corresponding in relative dimensions with the stepped portions D, E, F respectively. The channels terminate at one end in the face *i*. At an equal distance inwardly from the face *i* the channels are widened into seats N, O, P, respectively. The ends of the seats nearest the face *i* are not only transverse of, but at an inclination to, the channels, constituting transversely disposed inclined abutments or shoulders *n, o, p* respectively. These abutments form the inner ends respectively of radially graduated stepped portions *n', o', p'* intermediate the seats N, O, P, and the face *i*, resulting from the difference in the circumferential planes of the seats and the portions *n', o', p'*. Since the channels K, L, M, are of equal length the shoulders *n', o', p'* are arranged in substantial alinement transversely of the orifice. And as the depths of the seats and channels are radially graduated the said shoulders are in stepped relation. In the series of seats N alone or the lowest has its surface in unbroken continuity with its entrance channel K. The seats O and P each have the continuity of their surfaces with their respective channels L and M interrupted by the seat extending from the next lower channel; *i. e.* channel L by seat N, and channel M by seat O. The orifice J is of reduced diameter at its front end to form an abutment Q.

The interengagement of the parts A and B is effected as follows. The member A,

disposed as in Fig. 2 is introduced as a sliding fit into the member B from right to left as viewed in Fig. 6, the stepped portions D, E, F, entering the channels K, L, M respectively. The member A is then turned in the direction of the arrow, shown in Fig. 5, to bring the portions D, E, F, into the areas of the seats N, O, P, respectively, with the inclined faces d' , e' , f' , in frictional contact with the inclined abutments n , o , p , respectively. If the rotation be commenced as soon as the inclined shoulders of the two members register, the member A will simultaneously move slightly longitudinally bringing the shoulder h against the abutment Q, in which position the member A is securely held against longitudinal movement in both directions under pressure. Reversing the described movements serve to disengage the member.

The exposed face of the member A being flush with the exterior surface i^2 of the member B furnishes no opportunity to insert explosives in the resulting joint. The relatively short segments of uniform length insures a minimum of weight and thus facilitates the manipulation of the member A without detracting from its resistive qualities.

What I claim is,—

1. In a device of the type set forth, the combination with a stationary member, of a closure body, and a smooth segment upon the body comprising radially graduated stepped portions of substantially equal lengths with their front end faces in substantially the same plane, the end faces of the stepped portions being transversely inclined.

2. In a device of the type set forth, the combination with a hollow stationary member provided with a series of annularly arranged transversely inclined abutments, a closure member within the stationary member, and a segment upon the closure member provided with stepped portions adapted to bear against the abutments.

3. In a device of the type set forth, the combination with a stationary member, of a closure body, and a segment upon the body comprising radially graduated stepped portions of substantially equal lengths and provided with smooth segmental surfaces, the end faces of the stepped portions being transversely inclined.

4. In a device of the type set forth, the combination with a hollow stationary member provided with a plurality of longitudinally disposed radially graduated entrance channels, and with seats extending from the

several channels and transversely inclined with relation to the channels, and an annular series of radially graduated stepped portions with transversely inclined inner faces formed by the several seats and their respective channels, of a rotatable closure body, a segment upon the body provided with radially graduated stepped portions having inclined end faces adapted to enter the channels as a sliding fit and to abut against the inclined faces of the stepped portions of the stationary member when the body is rotated.

5. In a device of the type set forth, the combination with a hollow stationary member, of a closure member comprising a plurality of smooth longitudinally disposed segments interspaced from each other, each segment comprising a plurality of radially graduated longitudinally disposed stepped portions of equal length with their front end faces in the same plane and their rear ends transversely inclined.

6. In a device of the type set forth, the combination with a hollow stationary member, of a closure member comprising a plurality of smooth longitudinally disposed segments interspaced from each other, each segment comprising a plurality of radially graduated longitudinally disposed stepped portions of equal length with their front end faces in the same plane and their rear ends transversely inclined, said stationary member having a circumferential series of radially graduated longitudinally disposed entrance channels corresponding with said stepped portions.

7. In a device of the type set forth, the combination with a hollow stationary member, of a closure member comprising a plurality of smooth longitudinally disposed segments interspaced from each other, each segment comprising a plurality of radially graduated longitudinally disposed stepped portions of equal length with their front end faces in the same plane and their rear ends transversely inclined, said stationary member having a circumferential series of radially graduated longitudinally disposed entrance channels corresponding with said stepped portions, said entrance channels being widened into seats with one end disposed inclinedly transversely to said channels.

In testimony whereof I have affixed my signature in presence of two witnesses.

CARL J. LJUNGGREN.

Witnesses:

HORATIO E. BELLOWES,
WALTER LOUIS FROST.