



US00D511502S

(12) **United States Design Patent**
Kim

(10) **Patent No.:** **US D511,502 S**

(45) **Date of Patent:** **** Nov. 15, 2005**

(54) **BREAKER FOR ELECTRIC RAILROAD LINE**

(75) Inventor: **Han Byul Kim**, Cheongju-shi (KR)

(73) Assignee: **LG Industrial Systems Co., Ltd.**, Seoul (KR)

(**) Term: **14 Years**

(21) Appl. No.: **29/180,026**

(22) Filed: **Apr. 18, 2003**

(30) **Foreign Application Priority Data**

Nov. 29, 2002 (KR) 30-2002-0034277

(51) **LOC (8) Cl.** **13-03**

(52) **U.S. Cl.** **D13/160**

(58) **Field of Search** D13/137.3, 159, D13/160, 178, 162.1; 200/17 R, 50.26, 144 R, 147 R, 244, 304, 307, 318, 400, 401, 552; 218/157; 335/13, 10, 20, 35, 172, 167, 202; 361/93.3, 115, 173, 652, 673

(56) **References Cited**

U.S. PATENT DOCUMENTS

D319,627 S * 9/1991 Smith et al. D13/160
D320,386 S * 10/1991 Saunders et al. D13/160

5,120,921 A * 6/1992 DiMarco et al. 200/401
5,302,788 A * 4/1994 Link et al. 200/401
D367,265 S * 2/1996 Yamagata et al. D13/160
5,608,367 A * 3/1997 Zoller et al. 335/132
6,361,848 B1 * 3/2002 Katsube et al. 428/70
6,396,370 B2 * 5/2002 Leone et al. 335/35
6,479,774 B1 * 11/2002 Castonguay et al. 200/401

* cited by examiner

Primary Examiner—Stella Reid

Assistant Examiner—Selina Sikder

(74) *Attorney, Agent, or Firm*—Birch, Stewart, Kolasch & Birch, LLP

(57) **CLAIM**

The ornamental design for a breaker for electric railroad line, as shown and described.

DESCRIPTION

FIG. 1 is a perspective view of A Breaker for Electric Railroad Line showing the new design:

FIG. 2 is a front elevational view thereof;

FIG. 3 is a left-side elevational view thereof;

FIG. 4 is a right-side elevational view thereof;

FIG. 5 is a top plan view thereof; and

FIG. 6 is a bottom plan view thereof.

Those parts of the drawings shown in broken lines do not form part of the claimed design.

1 Claim, 3 Drawing Sheets

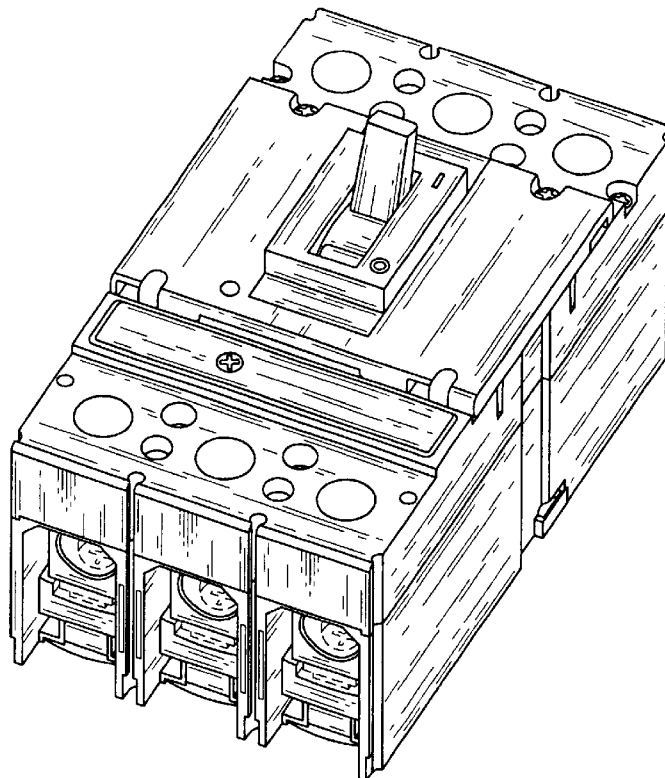

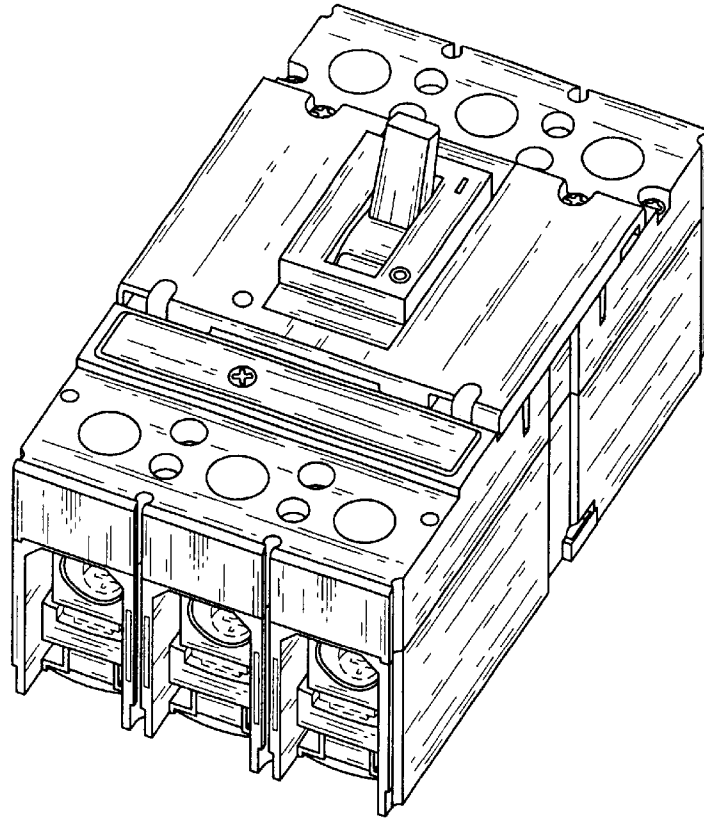

FIG. 1

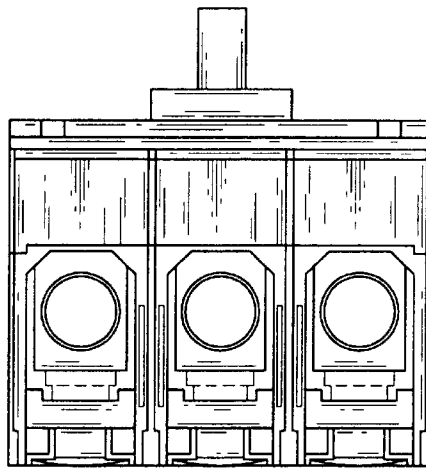

FIG. 2

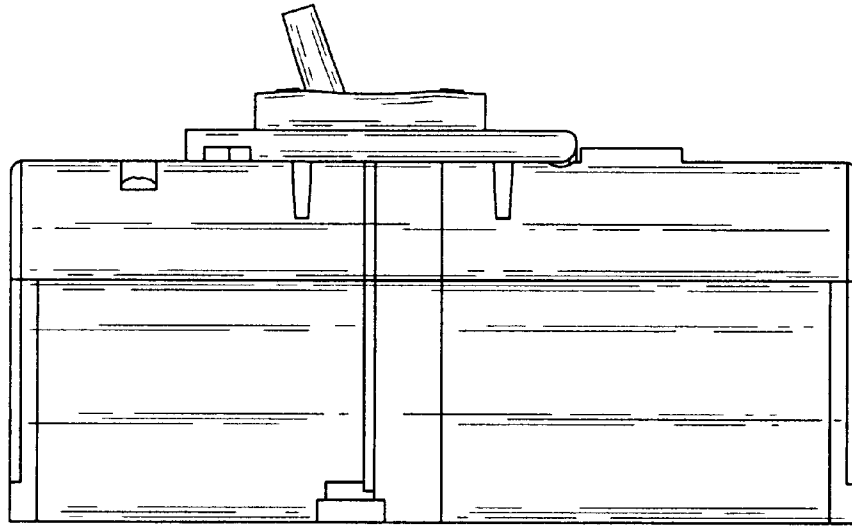

FIG. 3

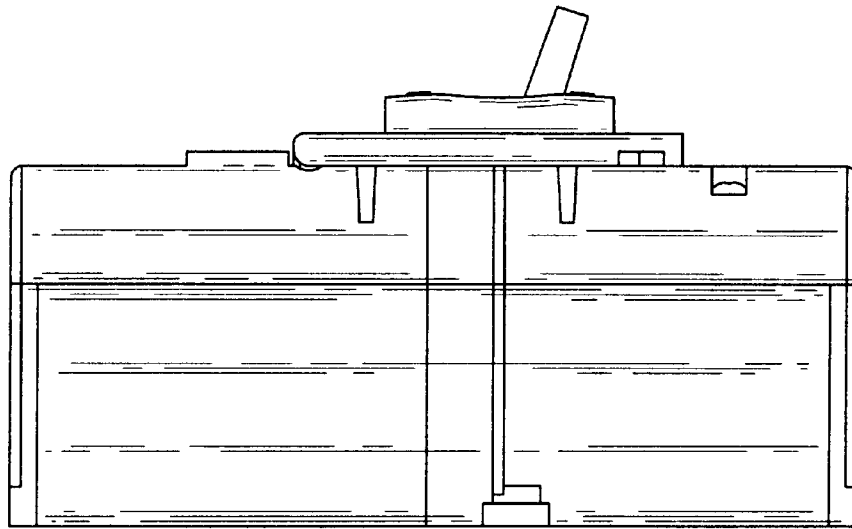

FIG. 4

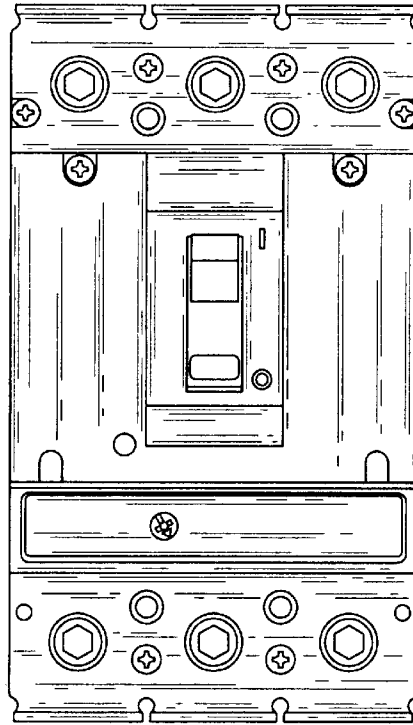

FIG. 5

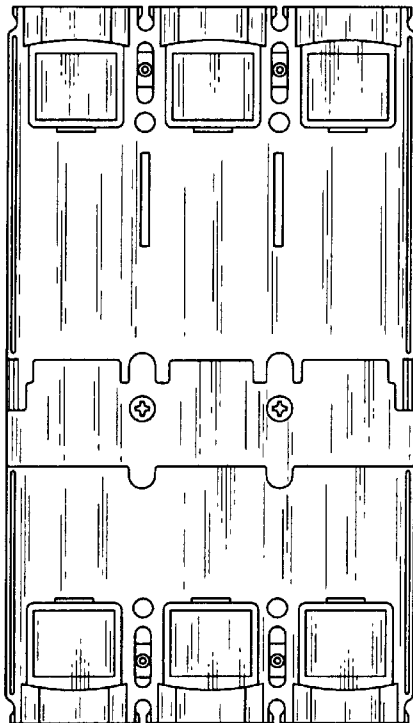

FIG. 6